

# Lo-Carbon Sentinel Multivent/Plus

- Reduces your carbon footprint
- Recognised in SAP PCDB
- Specific fan power as low as 0.16 W/l/s
- Suitable for use with external sensors and controllers
- Wireless control option for "X" models
- Complies with Building Regulations ADF and ADL
- Manufactured in the UK
- Integral adjustable overrun timer and delay on timer



Sentinel Multivent continuous mechanical extract ventilation, MEV is designed for the simultaneous ventilation of separate areas in the home or as a multipoint extraction system for a wide range of commercial applications. The units can be wall, ceiling or loft mounted. Where the ambient air has a high humidity content condensate drains are provided.

## In support of Sentinel Multivent, Vent-Axia offers:

- Practical advice on product selection and installation
- Guidance on solutions to meet legislation requirements
- Project management and site deliveries
- After sales support and maintenance information

## The need to improve efficiency

Sentinel Multivent has been designed to meet the exacting demands of developers, installers and users offering advanced control options and easier installation and commissioning.

- Demand Control - enables precise ventilation rate, is set in 1% increments based on property size
- Comfort mode allows homeowners to control when the unit runs and for how long to avoid disturbance
- Integral digital display allows the installer to select appropriate low, normal, boost and purge speeds to meet demand
- Manual and automatic control options
- Integral adjustable overrun timer and delay on timer
- Switched live and SELV connections
- Optional Wireless Control on "X" units
- Energy efficient EC/DC motors - 1/3 less energy lost to heat than a conventional AC motor
- Low Specific Fan Power (SFP) making it one of the most efficient products on the market

## Legislation

- Meets Building Regulations Approved Document F (System 3)
- Recognised in SAP PCDB up to kitchen + 6 wet rooms
- Meets carbon footprint reduction targets
- The need for better health: Removal of pollutants such as moisture, carbon dioxide and external fumes are all important factors

in maintaining indoor air quality, helping to create a healthier living environment

- The integral humidity sensor (Sentinel Multivent H) increases fan speed in proportion to relative humidity levels, saving energy and reducing noise
- The sensor also reacts to small but rapid increases in humidity, even if the normal trigger threshold is not reached. This unique feature ensures adequate ventilation, even for the smallest wet room
- Night time relative humidity increment setback feature suppresses nuisance tripping as humidity gradually increases with falling temperature

## SAP PCDB

In order to make the right choice, developers and contractors should refer to Building Regulations ADL1a, SAP 2012 and SAP PCDB.

SAP PCDB was launched in June 2006 to reward innovative ventilation manufacturers by testing and listing energy efficient products that assist in helping developers meet their Target Emission Rates (TER).

SAP is the underpinning methodology behind the Energy Performance Certificates and is used to demonstrate compliance with Building Regulations for Dwellings - Approved Document L (England and Wales), Section 6 (Scotland) and Approved Document F (Northern Ireland). SAP PCDB specifically relates to wholehouse ventilation systems and lists a number of Vent-Axia Mechanical Ventilation solutions which offer an improved SAP rating over and above the default for these product types.

## SEC Class

Model	SEC Class (inc. LDC)
Sentinel Multivent/Plus	B

## SAP PCDB Test Results (Sentinel Multivent and Multivent Plus)

Exhaust Terminal Configuration	Total Flow Rate (l/s)	SFP (W/l/s)
K+1	21	0.17
K+2	29	0.16
K+3	37	0.17
K+4	45	0.18
K+5	53	0.21
K+6	61	0.24

To assist developers and contractors Vent-Axia can provide detailed scheme designs together with installation guidance and training.

## Your Carbon Footprint

Carbon footprint is a measure of the amount of carbon dioxide (CO<sub>2</sub>) emitted through the burning of fossil fuels. From a residential and commercial building perspective, it is the amount of carbon generated when you consume a kiloWatt (kW) of electricity. Reducing a building's carbon footprint will ultimately reduce electricity bills and save money for every individual household or business. It will also help meet the UK target for the reduction of emissions, as well as allowing you to help the environment.

## Model

	Stock Ref
Sentinel Multivent H	445655B
Sentinel Multivent HX	495360
Sentinel Multivent HX CO <sub>2</sub>	495361
Sentinel Multivent Plus H	407849A
Sentinel Multivent Plus HX	495362
Sentinel Multivent Plus HX CO <sub>2</sub>	495363

## Accessories



	Stock Ref
Anti Vibration Mounts (Pack of 4)	68MP033G

## Dimensions (mm)

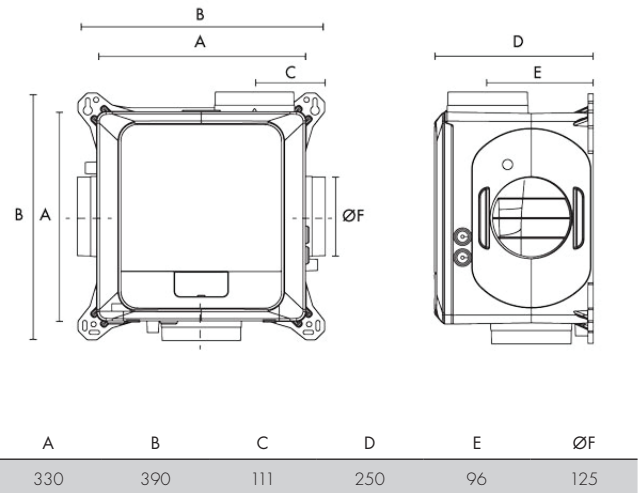

## Performance Guide

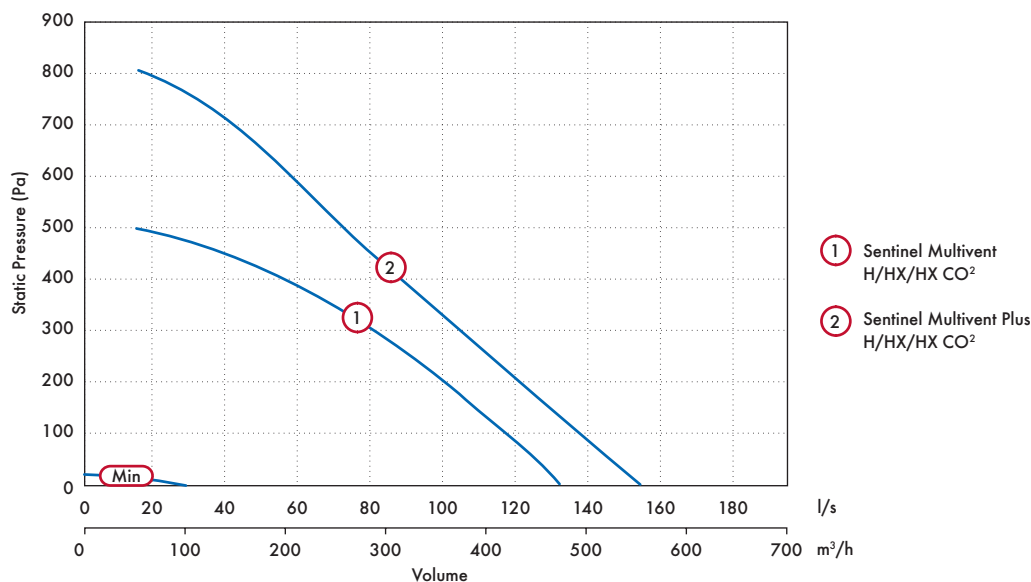

Stock Ref	Model	Curve Ref	FID (l/s)	Power Watts	IP Rating
445655 / 495360 / 495361	Multivent	1 (max)	128	52	IPX2
407849 / 495362 / 495363	Multivent Plus	2 (max)	159	85	IPX2

## Sound Data

Model	Speed	Test Mode	Octave Band (Hz) Sound Power Levels, dB								LwA	SpL @ 3m
			63	125	250	500	1k	2k	4k	8k		
Sentinel Multivent	20%	Extract	32.5	50.7	41.9	37.5	28.4	19.4	17.8	22.3	38.0	20.5
		Breakout	28.7	37.6	32.5	29.6	20.9	14.8	17.9	22.7	30.5	10.0
	40%	Extract	33.4	51.3	52.7	48.2	41.8	38.0	24.0	22.8	49.2	31.7
		Breakout	34.1	52.7	42.6	38.9	30.3	24.8	18.5	22.6	42.0	21.5
	60%	Extract	38.2	53.3	70.5	58.9	49.5	46.0	35.8	27.2	61.5	44.0
		Breakout	44.8	48.4	54.4	45.4	37.6	32.6	23.6	22.8	47.4	26.9
	80%	Extract	41.7	55.5	70.3	60.6	55.3	52.7	43.5	35.9	64.2	46.7
		Breakout	41.8	51.6	61.9	50.9	43.5	39.5	30.3	23.9	55.1	34.6
	100%	Extract	46.3	58.1	75.1	66.7	60.1	58.0	49.1	43.3	70.2	52.7
		Breakout	46.0	54.0	63.2	55.3	47.8	44.6	35.7	27.0	58.3	37.8

Tested according to BS EN 13141-6:2010. Breakout quoted spherical. Extract quoted hemispherical.

Model	Speed	Test Mode	Octave Band (Hz) Sound Power Levels, dB								LwA	SpL @ 3m
			63	125	250	500	1k	2k	4k	8k		
Sentinel Multivent Plus	20%	Extract	30.3	49.6	43.5	40.4	33.2	25.2	18.2	22.4	40.3	22.8
		Breakout	30.5	39.8	35.3	31.3	22.3	16.5	17.9	22.8	32.5	12.0
	40%	Extract	43.5	54.7	60.8	54.5	46.2	42.5	31.0	24.5	54.5	37.0
		Breakout	47.0	49.3	54.0	42.1	33.9	29.1	20.6	22.6	45.7	25.2
	60%	Extract	40.8	55.2	67.0	61.0	54.0	50.9	41.3	33.3	62.1	44.6
		Breakout	40.1	51.2	58.7	48.2	41.3	37.4	28.4	23.5	52.0	31.5
	80%	Extract	45.5	57.6	79.1	66.3	59.7	57.5	48.5	42.7	73.2	55.7
		Breakout	45.6	54.6	64.5	54.7	46.5	44.2	35.2	26.5	59.1	38.6
	100%	Extract	52.7	61.8	71.6	81.8	66.1	62.7	54.0	49.2	77.8	60.3
		Breakout	56.0	56.6	61.2	63.1	51.3	49.0	40.4	31.4	60.9	40.4

Tested according to BS EN 13141-6:2010. Breakout quoted spherical. Extract quoted hemispherical.

## Sentinel-X Controllers



### Internal Temperature and Humidity - Wireless - Battery

Room mounted humidity and temperature sensor for wired or wireless communication with a compatible system. Using an in-built RF 868 MHz (Wireless radio frequency), or RS485 (Wired connection) communication method whilst being powered by batteries.

- Dimensions (HxWxD) (mm) 60 x 60 x 22
- 2 x AAA Batteries included
- Temperature range 0~60°C
- Relative humidity range 0-90% RH
- Wireless range 20m closed/100m open
- RF 868MHz Wireless or RS485 Wired communication
- Status LED indicator for pairing, health check and fault conditions
- Mounted using provided back plate

Stock Ref  
**496431**



### 4 Speed Switch with Temperature and Humidity - Wireless - Battery & 240V

Room mounted Speed Switch for wireless communication with a compatible system. Using an in-built RF 868 MHz (Wireless radio frequency) communication. Battery and 240V model options.

- Dimensions (HxWxD) (mm) 90 x 90 x 17
- 2 x AAA Batteries (Battery Model) / Power supply 240V (240V Model)
- Temperature range 0~60°C
- Relative humidity range 0-90% RH
- Wireless range 20m closed/100m open
- RF 868MHz Wireless
- Mounted using provided back plate or compatible with a standard single gang or surface mounted pattress box
- Status LED indicator for pairing, health check and fault conditions

Model	Stock Ref
White (Battery)	<b>496437</b>
Black (Battery)	<b>497689</b>
White (240V)	<b>496620</b>
Black (240V)	<b>497693</b>



### Internal Temperature and Humidity - Wireless - 240V

Room mounted humidity and temperature sensor for wired or wireless communication with a compatible system. Using an in-built RF 868 MHz (Wireless radio frequency), or RS485 (Wired connection) communication method whilst being powered by a local 240V supply.

- Dimensions (HxWxD) (mm) 90 x 90 x 17
- Power supply 240V
- Temperature range 0~60°C
- Relative humidity range 0-90% RH
- Wireless range 20m closed/100m open
- RF 868MHz Wireless or RS485 Wired communication
- Compatible with standard single gang or surface mounted pattress box
- Status LED indicator for pairing, health check, faults & air quality traffic light index

Stock Ref  
**496429**



### CO<sub>2</sub>, Temperature and Humidity - Wireless - 240V

Room mounted CO<sub>2</sub> sensor for wired or wireless communication with a compatible system. Using an in-built RF 868 MHz (Wireless radio frequency), or RS485 (Wired connection) communication method whilst being powered by a local 240V supply.

- Dimensions (HxWxD) (mm) 90 x 90 x 17
- Power supply 240V
- Temperature range 0~60°C
- Relative humidity range 0-90% RH
- CO<sub>2</sub> Range 0-2000 PPM
- Wireless range 20m closed/100m open
- RF 868MHz Wireless or RS485 Wired communication
- Compatible with standard single gang or surface mounted pattress box
- Status LED indicator for pairing, health check, faults & air quality traffic light index

Stock Ref  
**496433**



### PIR Sensor - Wireless - 240V

Room mounted PIR sensor for wired or wireless communication with a compatible system. Using an in-built RF 868 MHz (Wireless radio frequency), or RS485 (Wired connection) communication method whilst being powered by a local 240V supply. Room mounted presence detector for min/max or on/off control. Wall or ceiling mounting.

- Dimensions (HxWxD) (mm) 90 x 90 x 17
- Power supply 240V
- 5-25min run on timer
- PIR Range 3m
- Compatible with standard single gang or surface mounted pattress box
- Wireless range 20m closed/100m open
- RF 868MHz Wireless or RS485 Wired communication

Stock Ref  
**496438**