



Vent-Axia[®]

Improving Indoor Air Quality since 1936

Heat Recovery Retrofit Solution

Edition 1

www.vent-axia.com/social-housing

A close-up photograph of two men in a professional setting. The man on the left, with short brown hair, is wearing a blue and white checkered shirt and is looking down at a notepad. The man on the right, with short black hair, is wearing a dark grey sweater over a white collared shirt and a plaid scarf with a white fur lining. He is smiling and looking towards the other man. The man on the left is holding a blue pen and writing on the notepad. The background is a plain, light-colored wall.

We're here to help...



Heat Recovery Retrofit Solution

Delivering decarbonisation in Social Housing on the path to Net Zero homes



Lo-Carbon Heat Save



Lo-Carbon Tempra



Lo-Carbon Calido



Without providing adequate ventilation, one of the risks associated with delivering a low energy and Net Zero carbon retrofit is the increasing airtightness in homes.

This creates areas where moisture condenses leading to mould growth which blights many homes across the UK.

Social housing providers, landowners and property managers recognise the challenges and are looking for solutions to protect their housing stock and residents.

This is where Vent-Axia is able to provide you with the right ventilation solution to support your journey towards Net Zero and healthier homes.

Discrete
Installation

Low
Energy

Low
Maintenance

Ultra
Quiet

Improved
Health

NET ZERO

Refurbishment and its role in Net Zero by 2050



We use up to 40% of our energy in buildings, with around half of that being used for heating, cooling and other operational energy. With most of the housing stock that will exist in 2050, already built, it is imperative that we improve the heat loss of the existing stock through deep, energy efficient refurbishment.

Decarbonisation Fund

The UK Government has announced that it will reduce greenhouse gas emissions by 68% by 2030, compared to its 1990 levels and has committed to getting all social housing stock to Energy Performance Certificate (EPC) Grade C. The Social Housing Decarbonisation Fund (SHDF) will upgrade a significant amount of the social housing stock currently below EPC level C up to that standard. It will support the installation of energy performance measures in social homes in England, and help:

- ✓ Deliver warm, energy-efficient homes
- ✓ Reduce carbon emissions
- ✓ Tackle fuel poverty
- ✓ Improve existing housing stock
- ✓ Improve the comfort, indoor air quality for all social housing tenants

Ventilation without the heat loss

As homes improve with greater levels of insulation and become more airtight, it is important that they are adequately ventilated whilst at the same time ensuring a healthier living environment. However, by ensuring there is healthy air movement within a home, extracting heated air can be expensive for the end user. The Heat Recovery Retrofit Solution range from Vent-Axia has been specifically developed to provide increased ventilation whilst minimising unnecessary heat loss through heat recovery technology.

We use up to
40%
of our energy in
our buildings



A UK first retrofit solution

“Retrofit isn’t just about reducing carbon emissions. A best practice retrofit should reduce fuel bills and also improve health and wellbeing.”

(Climate Emergency Retrofit Guide, LETI)

A UK first - PAS2035: 2019 ready decentralised solution

From June 2021, compliance with both PAS 2030: 2019 and PAS 2035: 2019 is mandatory for all companies installing energy efficient measures under the Trustmark scheme, which includes installing ventilation. The new range from Vent-Axia has been specifically designed for easy, lower cost retrofit of heat recovery to comply with the requirements of PAS 2035: 2019. Our technology is the first UK compliant decentralised solution making installation much simpler and removing what has up until now been only achievable with complex, high-cost duct installation. Replacing what has historically been a central ducted heat recovery unit, with smaller easy to install wall and ceiling units, it dramatically reduces the complexity of installation and the cost for planned work managers, whilst controlling unforeseen install expenditures.

► Installation example of the Vent-Axia Heat Recovery Retrofit Solution, see page 18

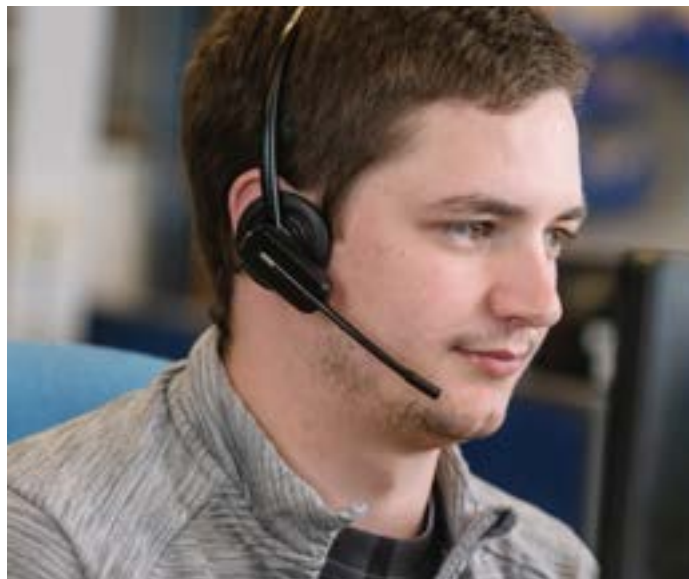
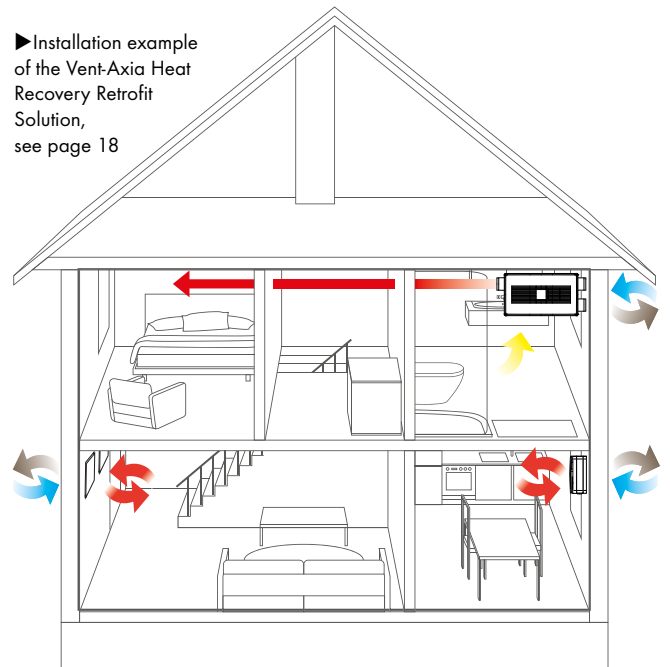

Support through our national sales network

Support in making the right decisions, the Vent-Axia Social Housing sales team offer a design and product selection service along with an energy calculator to help estimate savings that can be expected through the installation of Vent-Axia’s low carbon products on targeting and EPC level C home.



Lo-Carbon Heat Save

Fresh air without the chill

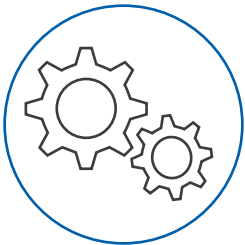

Fully Customisable

The Sentinel Zone Controller can be programmed to operate up to eight Heat Save units. Functions such as heat recovery, continuous ventilation and a pause feature can be controlled with a few quick swipes.



Easy Install

The Heat Save is a simple through the wall heat recovery unit designed for living rooms and bedrooms in a single or multi story property. As it does not require ducting, installation time is greatly reduced.

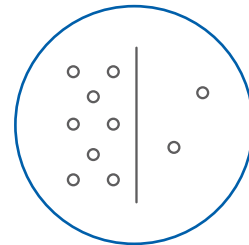

Built-In Air Filtration

With an easy to replace and washable filter built into the unit, fresh incoming air passes through to ensure that only clean air enters the room.

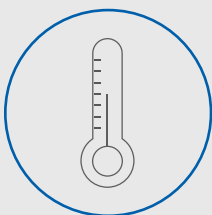

Up to 84% Heat Recovery

Designed for living rooms and bedrooms in single and multi-family buildings, the Lo-Carbon Heat Save can recover up to 84% heat to reduce energy bills as well as the properties' carbon footprint.



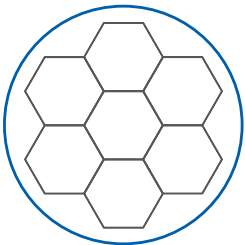

Ceramic Heat Exchanger

Inspired by nature, the ceramic heat exchanger includes a hexagon design to maximise surface area for heat recovery.

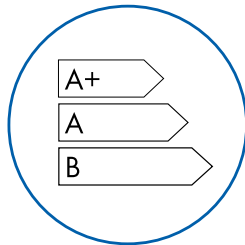

Reduce Carbon Footprint

With up to 84% of lost heat being filtered back into the property, this reduces the property's heating demand resulting in less carbon emissions and energy usage.

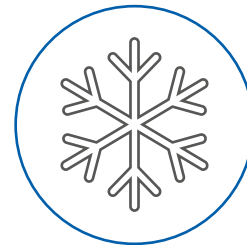

Anti-Frost Protection

The Heat Save switches between supply and extract every 70 seconds, this means warm air passing through the unit's ceramic heat exchanger provides much needed frost protection.



Up to 5 Year Warranty

Sustainably improving the indoor air quality of habitable rooms with the added peace of mind of a five year warranty.



Vent-Axia Lo-Carbon Heat Save

- Suitable for improving indoor air quality in habitable rooms
- Fully customisable ventilation via a control panel
- Easy to install, no need for ducting, wall sleeve included
- Easily maintained with cleanable filter and ceramic heat exchanger
- 5 year warranty for peace of mind
- Up to 84% heat recovery to reduce energy bills
- Anti-frost protection built in
- Replace extracted air with filtered air
- Reduce the home's carbon footprint and save money on energy bills

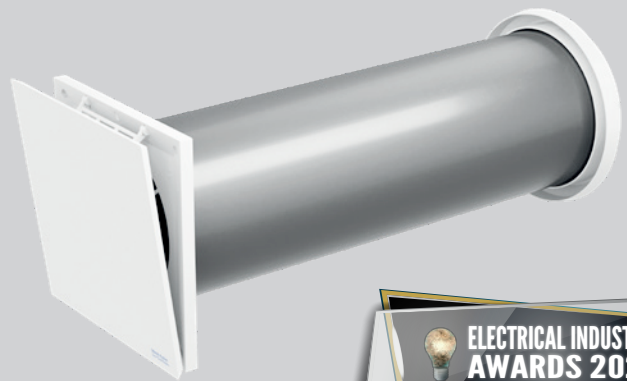

Through-The-Wall Heat Recovery Unit

The Vent-Axia Lo-Carbon Heat Save is a ventilation unit designed for living rooms and bedrooms in single and multi-family buildings. The unit is usually located in an exterior wall to provide new air to the room.

The Vent-Axia Lo-Carbon Heat Save uses a reversible fan to extract dirty air from the room and replace it with outside air 70 seconds later. This air passes through a filter to ensure that clean air enters the room. These systems work best in pairs as when one unit is extracting, the other can be supplying air to provide a balanced ventilation system. They are controlled by a SENWZP Sentinel wired zone controller which can operate up to 8 units in synchronization. This provides a single room or whole house balanced ventilation system with heat recovery.

As well as filtering the air, the Vent-Axia Lo-Carbon Heat Save uses a thermal accumulator to extract warmth from the outgoing air and uses it to temper the incoming air to avoid the feeling of cold drafts and recover heat that would otherwise be lost to the outside.

Models

Vent-Axia Lo-Carbon Heat Save

Decentralised ventilation system with up to 84% heat recovery. Compact design for apartments or houses with 180mm diameter, ideal for refurbishment. Includes reversible fan with a thermal accumulator, external wall grille, wall sleeve, dust filter. Requires 1x SENWZP (496037) wired zone controller per installation of 8 units.

Stock Ref
496036

Accessories

Model

Sentinel Wired Zone Control Panel (SENWZP)	Stock Ref 496037
Spare Inner Cover 220x220	496108
Heat Save PM10 ISO Coarse 60% (formerly G4) filter	496038
External Wall Sleeve 160x745	495328
Spare Wall Sleeve 160x495	496105
Spare Reversible Fan	496110
Spare Thermal Accumulator	496111
Spare Weather Protection Grille	496107
Sound Absorbing Insert	496109

Performance

Wall opening:	167 - 180 mm
Wall thickness with plaster/render:	>290 mm
Supply Air flow:	2.8 - 12.0 l/s
Extract Air flow:	2.8 - 12.0 l/s
Average Air flow:	1.4 - 6.0 l/s
Power consumption:	1 - 3W
Sound emission:	18 - 36 dB(A)
Heat Recovery:	84%
Temperature range:	-20 - 50 °C

Typical Installation

The Vent-Axia Lo-Carbon Heat Save can be fitted in a 167mm - 180mm diameter hole. Maximum wall thickness is 460mm or 745mm with optional wall tube (see accessories). The wall sleeve length (included up to 460mm) can be cut down to size to fit any wall thickness.

Vent-Axia Lo-Carbon Heat Save units work best in pairs. When one unit is extracting, the other can be supplying air to provide a balanced ventilation system. They alternate direction every 70 seconds when the thermal accumulator on the extract unit has warmed up allowing the supply air to benefit from these thermal gains. They are controlled by a SENWZP Sentinel wired zone controller. This is fully modular and controllable with customised ventilation profiles available so that every room in the home can have the perfect ventilation.

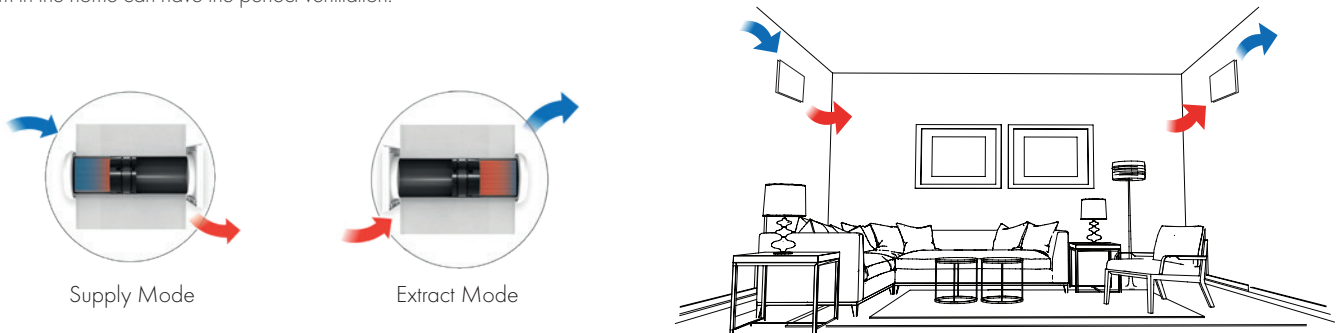

Dimensions (mm)

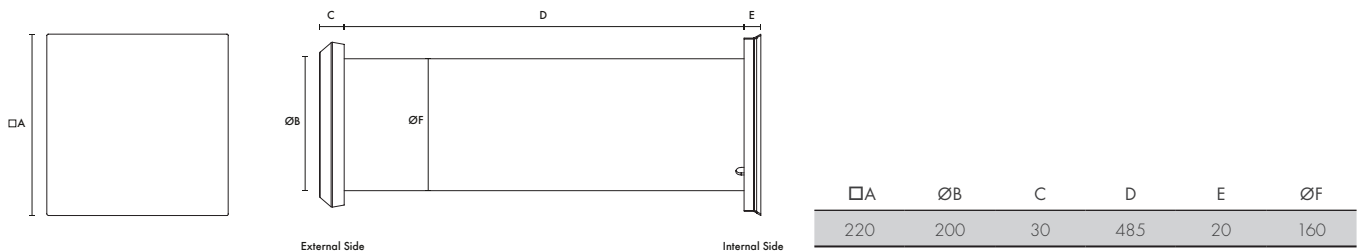

Sound @ 1m dB(A)

Fan Speed	With sound absorbing insert	Without sound absorbing insert
25%	20.0 dB(A)	16.8 dB(A)
35%	23.0 dB(A)	20.8 dB(A)
50%	30.7 dB(A)	26.3 dB(A)
75%	37.0 dB(A)	Not tested
100%	43.0 dB(A)	33.7 dB(A)



Lo-Carbon Tempra

Through-The-Wall Heat Recovery Unit

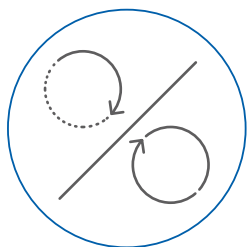

Continuous or Intermittent

Depending on a property's ventilation need, the Tempra can operate between 6 and 15 l/s at continuous extract and 15 l/s for intermittent.

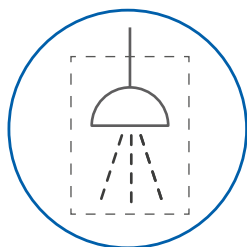

IPX4 Rated

Suitable for installation in zone 2 of a bathroom, the Lo-Carbon Tempra is protected against splashes of water.

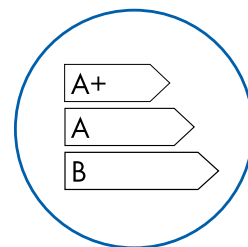

Reduces Carbon Footprint

With up to 78% of lost heat being filtered back into the property, this reduces the property's heating demand resulting in less carbon emissions and energy usage.

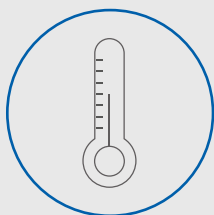

Up to 78% Heat Recovery

The Tempra's unique heat exchanger is designed to warm air as it re-enters the property. Stale warm air is removed, it passes through the heat exchanger where the heat is then transferred to the fresh incoming air. This process can save up to 78% of heat lost.

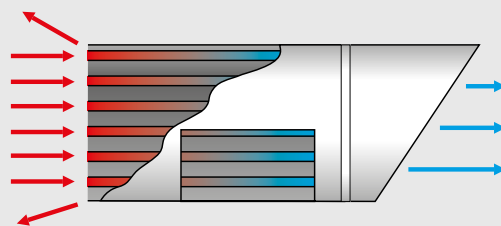

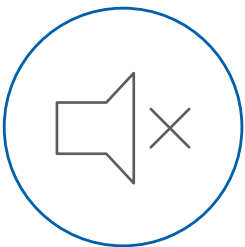

Helps Prevent Noise Ingress

The heat exchanger cell also acts a sound barrier to outdoor noises, such as traffic in built up areas.

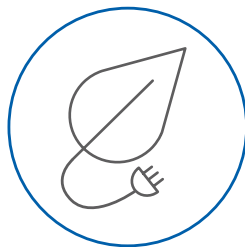

Low Power Consumption

Using just 3.2W on its lowest speed, the Tempra uses less energy than most other household products. This not only makes it incredibly energy efficient, it also help save money on electricity bills.

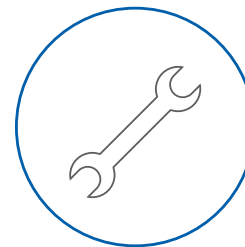

Easy Install

With a 100mm spigot, the Tempra can replace any 100mm kitchen, bathroom, toilet or utility room fan. It also comes with two spigot length options depending on the thickness of the wall making it a simple through the wall install.



Up to 5 Year Warranty

Sustainably improving the indoor air quality of habitable rooms with the added peace of mind of a seven year warranty.



Lo-Carbon Tempra/SELV

- Fits in 100mm diameter hole - ideal for refurbishments
- Up to 78% heat recovery
- Available in 2 wall depths: 320mm and 460mm
- Reduces the home's carbon footprint
- IPX4 rated
- Summer setting (extract only)
- Helps prevent noise ingress
- Continuous running or intermittent extract
- Meets current Building Regulations Approved Documents F and L
- Low power consumption - only 3.2 W



Through-The-Wall Heat Recovery Unit

The Vent-Axia Lo-Carbon Tempra is designed to fit in 100mm diameter hole and is suitable for refurbished properties in kitchens, bathrooms, toilets or utility rooms. The unit meets the performance requirements for continuous extract fans under the current Building Regulations Approved Document F.

The Tempra is available in three models, a P version with pullcord control, a T version with overrun timer and an HTP version with built-in pullcord, overrun timer and humidistat. Two spigot lengths are available; 320mm and 460mm.

The manual summer setting allows the unit to be set to extract only, helping to prevent a dwelling becoming too warm in hot summer conditions.

Performance

The Tempra can be set to run continuously at 6 l/s or 9 l/s, boosting up to 15 l/s, recovering heat from extracted air and returning it to the dwelling. The unique, compact heat exchanger has a temperature efficiency up to 78%, saving energy and reducing your carbon footprint. For intermittent extract the Tempra is set to 15 l/s.

Tempra is also designed so that the replacement air being introduced is at a reduced rate ensuring that the room being ventilated is still under a slight negative pressure. This ensures that fresh air is brought into the room from the rest of the house preventing humid air migrating.

The Lo-Carbon EC/DC motor with twin impellers consumes as little as 3.2 Watts on trickle rate and runs almost silently at only 20dB(A).

Typical Installation

The unique heat exchanger design allows the Tempra to be fitted in a 100mm diameter hole, allowing it to replace standard 100mm extract fans while giving all the benefits of heat recovery. Maximum wall thickness is 460mm.

A longer version of the Tempra is available, designed for installations where the wall thickness is between 321mm and 460mm. 460mm models are identified by an 'L'.

Models

Lo-Carbon Tempra P (Pullcord)

Constant trickle speed with pullcord to boost or intermittent operation by pullcord.

Model	Stock Ref
320mm P	443312
320mm SELV P	444368
460mm LP	403832
460mm SELV LP	403833

Lo-Carbon Tempra T (Timer)

Constant trickle speed with switch live to boost or intermittent operation by switch live.

Model	Stock Ref
320mm T	443310
320mm SELV T	444369
460mm SELV LT	403835

Lo-Carbon Tempra HTP (Humidistat/Timer/Pullcord)

Constant trickle speed with humidistat and linked overrun timer to boost or intermittent operation by switch live.

Model	Stock Ref
320mm HTP	443311
320mm SELV HTP	444370
460mm LHTP	403836
460mm SELV LHTP	403837

Accessories

100mm High Rise Kit

320mm white duct with black seal.

Model	Stock Ref
100mm High Rise Kit	449011

Wall Kit

Extendable Wall Tube suitable for both spigot lengths.

Model	Stock Ref
Wall kit	445529

150mm Conversion Kit
 For replacement of 150 diameter fan.
 Stock Ref
 403847

Dimensions (mm)

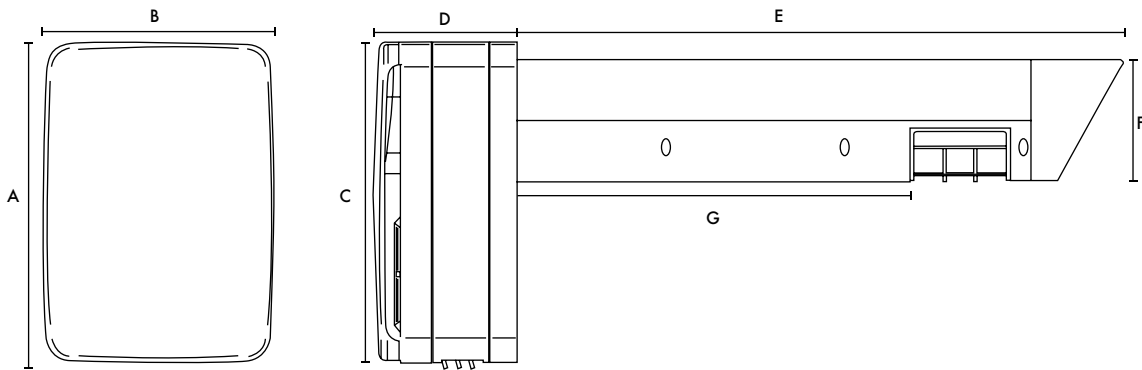

	A	B	C	D	E	F	G
Standard	266	190	262	117	496	99	321
Long	266	190	262	117	636	99	461

Performance

Model	Extract Performance l/s			Power Consumption Watts			Sound @dB(A)*		
	Trickle Low	Trickle High	Boost	Trickle Low	Trickle High	Boost	Trickle Low	Trickle High	Boost
Lo-Carbon Tempra (All Models)	6	9	15	3.2	5.7	26.6	20	22	36

*Octave band frequency range of 250Hz to 4KHz at 3m. Unit mounted on a reflective surface.

Heat Exchange - what is heat recovery?

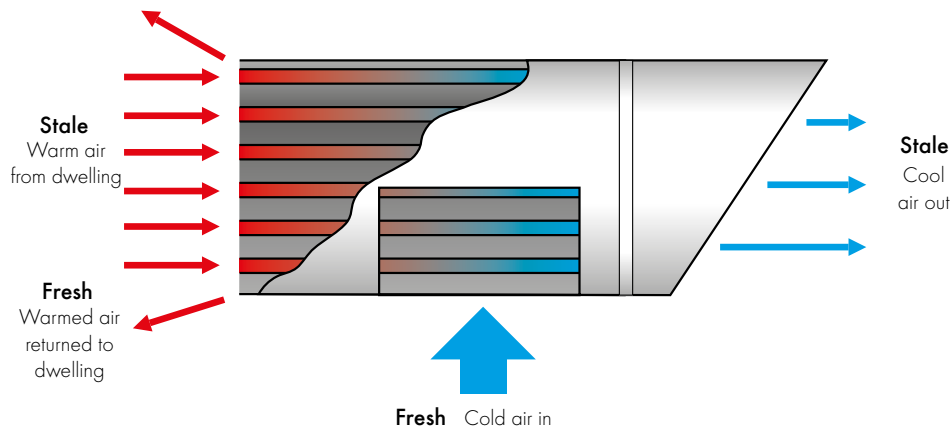

Lo-Carbon Calido

Replaces the air and retains the heat

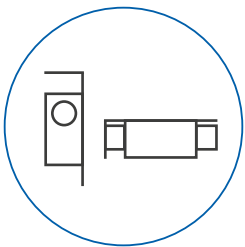

Wall or Ceiling Mounting

The Lo-Carbon Calido can be installed in one of two ways, ensuring that both ducting and electrical wiring can be installed as neatly as possible.

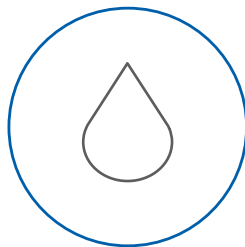

Intelligent Humidistat

The Lo-Carbon Calido automatically adjusts itself to the conditions in the property however the relative humidity function can be adjusted on the control panel to start below 88% if required.

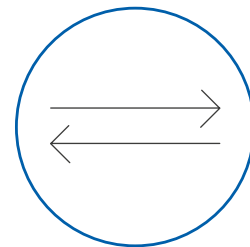

Heat Recovery

The Lo-Carbon Calido is designed to recover up to 80% heat. The heat from the stale extracted air will be used to warm up the fresh incoming air.

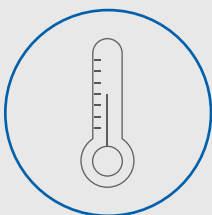

Up to 80% Heat recovery

Lo-Carbon Calido has energy class A - a confirmation that the unit is both an environmentally friendly and a very energy-efficient ventilation solution.



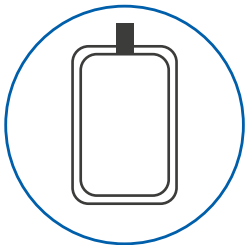

Easy Maintenance

The unit comes with a replaceable filter that can be changed depending on the selected interval - 3 to 12 months options available. The light indicator will display when it is time for a new filter.

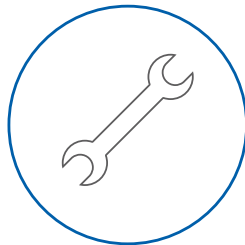

Easy Install

Using the handy drilling template, the Vent-Axia Lo-Carbon Calido is easy to install in retro fit properties where a traditionally whole house heat recovery unit is not possible.

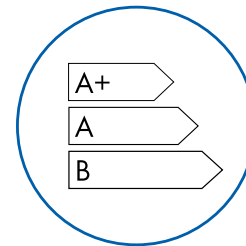

Reduces Carbon Footprint

With up to 80% of lost heat being filtered back into the property, this reduces the property's heating demand resulting in less carbon emissions and energy usage.



Up to 5 Year Warranty

Sustainably improving the indoor air quality of habitable rooms with the added peace of mind of a five year warranty.



Vent-Axia Lo-Carbon Calido

- Up to 80% heat recovery to reduce energy bills
- Reduce the home's carbon footprint and save money on energy bills
- Ideal for retrofit applications
- Intelligent controls to eliminate condensation within the unit
- Adjustable airflows
- Filter replacement indicator ensures continuous good indoor air quality
- Incredibly reliable due to EC motor
- CE and S Mark - independently tested and certified for safety
- IP24 rated
- 5 year warranty



Discrete Whole House Heat Recovery

The Vent-Axia Lo-Carbon Calido is designed to remove stale air from any habitable room and replace it with fresh air. This unit is designed to be ducted therefore it can benefit more than one room at a time i.e. if installed in a bathroom, stale and moist air will be extracted and fresh air will be supplied to other habitable rooms via installed ducting.

The Vent-Axia Lo-Carbon Calido offers up to 80% heat recovery which helps reduce the amount of heat lost from the property. This helps save money by reducing energy costs as well as reducing carbon emissions. The unit cleverly recovers heat from heat lost through extraction and reuses it to warm the air re-entering the property.

One unit can help improve the air quality of a whole house and with changeable filters it can help provide clean air all year round. With three air flow options available, the Vent-Axia Lo-Carbon Calido can be installed in many types of properties and its compact design means it will ventilate and recover heat quietly in the background. It can also be wall or ceiling mounted depending on space availability, making it perfect for many retrofit applications.

Models

Vent-Axia Lo-Carbon Calido

The Vent-Axia Lo-Carbon Calido is a robust unit with an IP24 rating and is double insulated for extra protection. It uses an EC motor, which is incredibly reliable and comes with a five year warranty.

Stock Ref
411133

Accessories

Model

Filter kit standard G4 2pcs

External wall kit 100mm

Exhaust air adaptor

Calido Controller

Stock Ref

411156

411163

411164

411331

Typical Installation

The Vent-Axia Lo-Carbon Calido requires two 100mm diameter holes - one to extract stale air and one to intake fresh air. It also comes with a drilling template for an easy install.

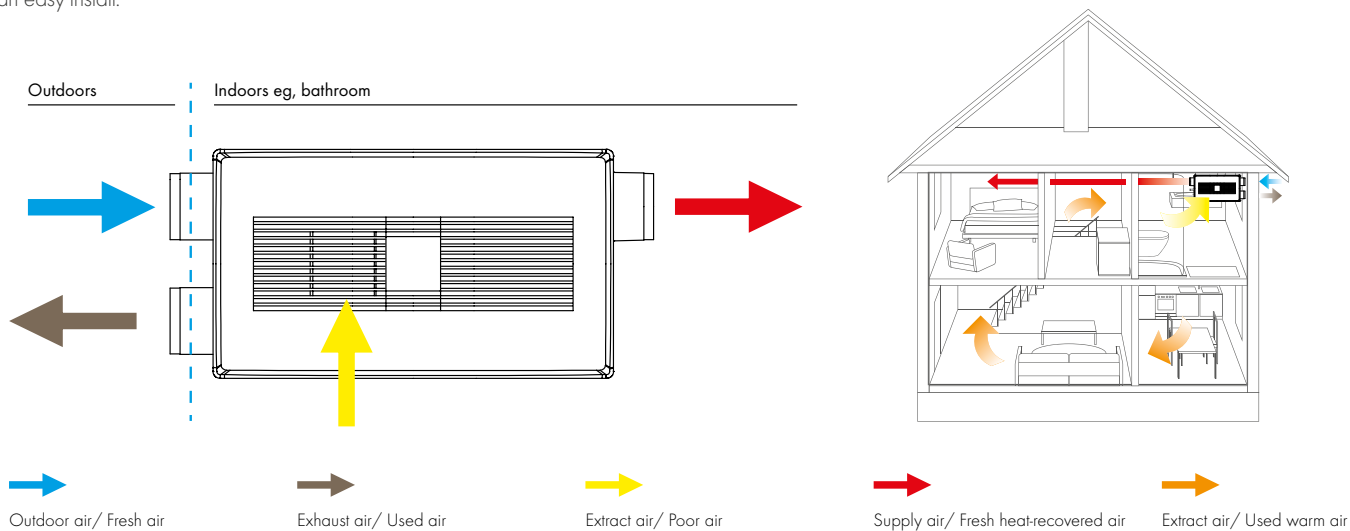

Dimensions (mm)

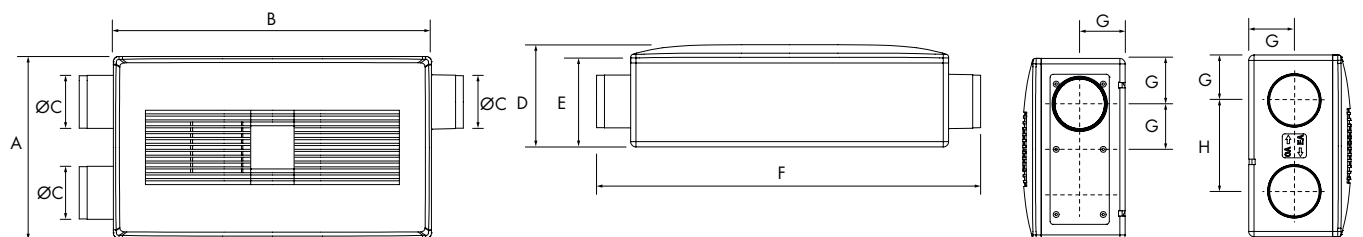

A	B	ØC	D	E	F	G	H
340	595	100	191	167	720	85	170

Performance

Wall opening:	100 mm
Balanced Air flow:	8.3 - 25 l/s
Power consumption:	3.5 - 25W
Sound emission:	19 - 35 dB(A)
Heat Recovery:	80%
Temperature range:	-30 - 35 °C



A Complete Range of Products

Delivering increased energy efficiency to homes

Decentralise Mechanical Ventilation with Heat Recovery (dMVHR)

Ideal when energy efficient heat recovery is required on a room-by-room basis. Easier to retrofit as compared to a wholehouse ventilation system. Decentralised Mechanical Ventilation with Heat Recovery (dMVHR) uses the heat from the stale air that is being extracted to warm up the fresh air that is coming in. Therefore bringing in fresh but pre-warmed air providing ventilation whilst also saving energy. This type of ventilation is ideal for refurbishment applications.

The Heat Recovery Retrofit Solution

How they work together:

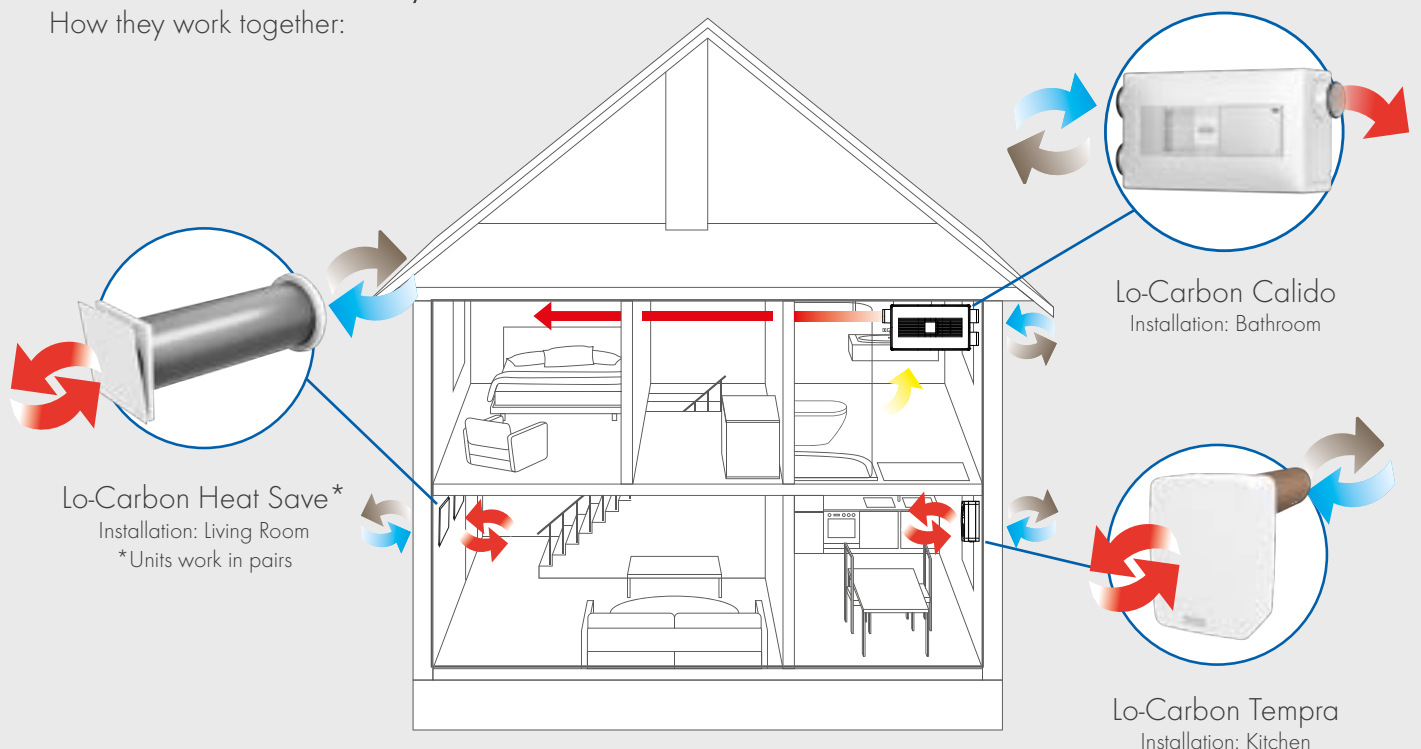

Outdoor air/ Fresh air



Exhaust air/ Used air



Extract air/ Poor air



Warm supply air/ Fresh heat-recovered air



A Wide Range of Solutions

More than just an innovative ventilation manufacturer



Advice

Our experienced consultants can provide impartial expert advice on condensation and mould complaints and issues you may be experiencing at the property, which will help determine if ventilation could be a solution to the problem.



Products

Designed with residents in mind, our social housing product solutions are powerful enough to remove moist air to help eradicate condensation and mould, at the same time recover heat, and save on energy costs leading to improved indoor air quality and comfort.



Support

Our expert ventilation consultants are always on-hand to assist with queries, offer their expert opinions, or even assist installers on trials of new ventilation products. Backed up by a knowledgeable and friendly technical support department, you can rest assured that Vent-Axia will always offer first class support.

Vent-Axia



Training

The ventilation industry is constantly changing and evolving. So are our customer's challenges and that is why we are on hand to offer practical, engaging and informative training. From CPD courses on mould and condensation to hands-on toolbox talks on installation, we can help you to stay ahead of the knowledge curve.



Downloads

Vent-Axia has simplified the way you can access information. Knowledge Hub provides you with our literature and comprehensive product information all in one place, at the touch of a button. Watch our video now to find out more.

www.vent-axia.com/knowledge-hub



VENT-AXIA CONTACT NUMBERS

Free technical, installation and sales advice is available

Sales Tel: 0344 856 0590
Tech Support Tel: 0344 856 0594
Tech Support Email: tech@vent-axia.com
Web: www.vent-axia.com
Email: sales@vent-axia.com

Supply & Service

All sales made by Vent-Axia Limited are made only upon the terms of the Company's Conditions of Sale, a copy of which may be obtained on request. As part of the policy of continuous product improvement Vent-Axia reserves the right to alter specifications without notice.



Download our Knowledge Hub app - Your new pocket expert.

Search, View, Share - It's that easy!



Made in Britain



0423