



**Vent-Axia**<sup>®</sup>

Improving Indoor Air Quality since 1936

# Specification Range

Edition 14

[www.vent-axia.com](http://www.vent-axia.com)



# Ventilation Solutions

A warm welcome to the latest edition of the Vent-Axia Specification Range catalogue.

As part of the ongoing drive for energy efficiency within Europe, ventilation devices over 30 Watts come under the scope of the Energy Related Products Directive that came into force on 1st January 2016. The legislation sets minimum performance criteria across a range of fans and ventilation devices under two sets of legislation; 'residential' ventilation and 'non-residential' ventilation. As a result of the legislation we have reviewed our products and where required made updates to ensure they comply. In line with Vent-Axia's drive to provide the best solution for our customer, we have taken the opportunity to update and improve some products at the same time as bringing the products in-line with ErP regulations. We have also improved the way we supply some of them - giving you more choice and flexibility over how you stock and sell the products.

This edition of our Specification Range catalogue shows the continued investment we are making in our products and services to improve and add to our already comprehensive range. In this catalogue, we have brought together our Lo-Carbon residential and our non-residential products in one place providing what we believe to be the best solutions for a wide range of specification today.

We have introduced many new models which expand upon our traditional, well-proven products as well as broadening our capabilities further with a whole host of innovations in Vent-Axia Lo-Carbon and energy reducing ventilation solutions.

For example, the EKF kitchen fan has a built in EC motor speed control, high temperature rating of up to 120 degrees, motor out of the airstream and specific fan powers of below 1 W/l/s; we believe there is no better solution available.

We thank you for your continued custom and feedback, and are always willing to answer any questions you may have. If you need to contact us, please email [sales@vent-axia.com](mailto:sales@vent-axia.com), or speak to your local representative who will be happy to help.

## Why choose Vent-Axia

Vent-Axia supplies ventilation to countries around the world, whose building regulations demand the most effective, sustainable and energy efficient ventilation solutions.

## We are with you all the way

- Unparalleled customer service
- Industry leading design support
- Providing support and solutions on-site

## Availability

- With the widest distribution network of any manufacturer in the UK we pride ourselves on having products available when and where you need them

## Product solutions

- Whatever the product category, we have the most energy efficient solutions available
- Unique solutions designed to fit into all your buildings
- With absolute focus on the end user we work hard to produce the quietest, most comfortable products for occupiers



Unparalleled Customer Service



On-site Support



Industry Leading Design Support



Widest UK Distribution Network



# Legislation

## Approved Document F 2010 - Means of Ventilation

The purpose of this regulation is to ensure adequate means of ventilation is provided for people in the building. According to the document, ventilation is the 'removal of stale air from a building and replacement with fresh outside air.'

By providing fresh outside air to breathe, ventilation assists in the dilution and removal of pollutants as well as a reduction in humidity/condensation, which combined create a more pleasant environment and relief for asthma and allergy sufferers.

Part F is a performance based whole building solution stating not only what should be achieved, but also guidance on how this can be achieved.

The pollutants in today's modern dwellings has lead to these changes, with the types of pollutant and the acceptable levels now detailed in the Approved Document Part F 2010.

Nitrogen Dioxide (NO<sub>2</sub>)

Carbon Monoxide (CO<sub>2</sub>)

Total volatile compounds (TVOC)

Bio-effluents (body odours)

Within ADF 2010, Ventilation requirements for new build properties reference the whole dwelling based on an analysis of floor area, number of bedrooms and occupants. There are four systems covered in ADF 2010 including Intermittent Extract Fans, Passive Stack, Continuous Mechanical Extract Ventilation (MEV) and Mechanical Ventilation with Heat Recovery (MVHR).

A guide called the 'Domestic Ventilation Compliance Guide' is available. This covers installation practices as well as sign off and commissioning.

Efficiency regulations require buildings to be better sealed and more airtight. In ADF 2010 there are two ventilation rates based on the design infiltration rate of your building. There is one rate for properties with infiltration rates over 5m<sup>3</sup>/h/m<sup>2</sup> (leakier properties) and a higher ventilation rate for properties below 5m<sup>3</sup>/h/m<sup>2</sup> (tighter properties). The practical outcome of this means that in airtight properties, the following applies:

- Trickle vents with intermittent fans are up to 50% bigger
- MVHR air-flow rates are increased

With MEV in properties at 5m<sup>3</sup>/h/m<sup>2</sup> or over no trickle vents are needed.

Guidance is available for ventilation of basements in houses and trickle ventilation for replacement windows.

Compliance with Part F requires installed performance to meet the ventilation rates quoted in the Document. This means that ventilation has to be commissioned and signed off by a competent person.

## Noise

With increasing airtightness the acoustic properties also improve leading to a reduction in external noise entering our dwellings. However this makes any noise generated inside the property even more noticeable, so in Part F a maximum noise level of 35dB(A) has been set for the trickle speed on continuous ventilation systems.

## Approved Document L 2013 - Conservation of Fuel and Power

These documents set minimum performance levels for ventilation efficiencies and reducing the consumption of the systems.

These regulations have brought some significant changes to the ventilation sector in a bid to improve both air quality and energy efficiency.

### Part L - Overview

- Target emission rates, along with fabric energy efficiency standards are aimed at reducing the carbon emissions by 6%
- Non-domestic building services compliance guide shows specific fan power requirements. Heat recovery efficiency minimums to EN308 test standard
- Specific fan power (SFP) targets of 1 W/l/s for new or replacement commercial kitchen extract systems
- Minimum energy efficiency level for all ventilation systems. New build and refurbishment applications for intermittent fans must have an SFP of less than 0.5 W/l/s.



# Energy Related Products Directive (ErP)

As part of the ongoing drive for energy efficiency within Europe, ventilation devices over 30 Watts now come under the scope of the Energy Related Products Directive. The legislation sets minimum performance criteria across a range of fans and ventilation devices under two sets of legislation; 'residential' ventilation and 'non-residential' ventilation. All relevant products in this literature have been updated as required by the ErP legislation.

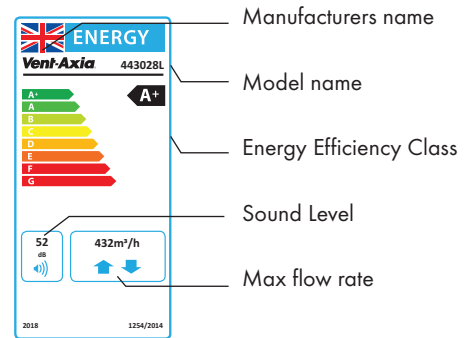

## Residential Products

Residential Products has a secondary directive which requires some products to carry an energy label as described below:

### Residential Ranges – Small fans

The majority of small residential fans are unaffected by the legislation as any device below 30 Watts is currently out of scope. The information on them is recorded however and can be found at [www.vent-axia.com/erp](http://www.vent-axia.com/erp)

### MVHR and MEV products

These products do come into the scope of the legislation and carry an energy label. There are some minimum energy efficiency requirements as well as the requirement for a summer bypass on heat recovery models. A small number of our products have been updated to ensure they meet these requirements.

### Energy Efficiency Class

Products within the scope of ErP now carry a rating that shows their Energy Efficiency Class. This information is called a 'SEC Class' and is provided in all product literature and on the energy label.

A product's SEC class is affected by how the product is controlled. This is referred to as Local Demand Control (LDC) and indicates how many 'sensors' a fan should have. The regulations require that single room fans, such as a bathroom fan, should have at least 1 sensor. Units that are ducted, such as an MEV unit, need to have more than one sensor. Examples of these are a pull cord/light switch or humidistat.

In our literature, where appropriate we have shown the rating if an additional LDC was added to a product. In those cases, you will see a table similar to the one below which has a heading (incl LDC). This is so you can choose the most efficient option for your needs.

### SEC Rating Example

Model	SEC Class*	SEC Class (incl. LDC)
HR200	C	B

## Non-Residential Ranges

Non-Residential products have had minimum performance and efficiency levels established, but there is no requirement to introduce energy labels.

Non-Residential ranges are split into a number of different categories dependent on their application and function. These can be described as follows:

- Fans**  
 These are products where there is a simple single case that directs air on and off the impellor. Examples include axial plate and case fans. These examples are out of scope of the legislation.
- Unidirectional ventilation units**  
 This includes products that are one direction only, and where there is a secondary housing around a fan. The impact of the efficiency legislation has meant that it has become virtually impossible to comply using a forward curved AC centrifugal fan.
- Bi-directional ventilation units**  
 These are product ranges that both supply and extract such as heat recovery.

There are now minimum energy requirements set for heat recovery efficiency. Any product with an efficiency of 72% or lower does not comply.

### Heat recovery minimum efficiency





# Future Direction

Things have moved on a bit since 1992 when ventilation was first introduced into the Building Regulations. Here is an overview of the changes from 2006.

**2006** – Part F included continuous ventilation for the first time.

Ventilation systems were being installed by skilled persons but the performance data was never tested. Part L changes meant that SAP Q products could be included as part of the dwelling's SAP calculations.

**2010** – Design, install and ensure its used correctly. With dwellings being designed with increased energy efficiency and reduced air permeability, ventilation systems now require specific flow rates and there is more demand for highly efficient heat recovery to help reduce the DER's. Ventilation is now required to be installed correctly with the installation recorded and measured plus there needs to be guidance to the home occupier as to how it operates.

**2013** – New Part L requirements meant a reduction in air leakage and increased air tightness.

These trends continue to drive the adoption of higher efficiencies and the importance of installation increases as the advantageous air from leakage is reducing further.

**2016** – With the commitments made in the recent COP21 meeting and the Paris climate agreement, focus on decarbonisation and energy efficiency is set to continue.

The Energy Performance of Buildings directive and the Energy related Product Directive are having an impact on the performance and efficiency standards of ventilation. These drivers will continue to develop and are expected to transform into standards in the future meaning an even greater focus on energy efficiency.

As we focus our efforts to drive down the energy that we use in buildings, the risk of airtight, well insulated buildings being the potential cause of respiratory problems increase. Therefore the importance of well-designed and well installed systems that perform as designed increases. This will lead to increased focus on competence when installing ventilation and is likely to drive advances in the way installers are trained.

## Things to Remember

- Airflow performance
- Minimum energy efficiency limits
- Good installation
- Use by occupiers



# Contents

## LO-CARBON RESIDENTIAL FANS

Page A1-A28



Vent-Axia Lo-Carbon iQ  
- Up to 37l/s

Page A3-A4



Vent-Axia Pureair Sense  
- Up to 39l/s

Page A5-A6



Lo-Carbon Svara  
- Up to 30l/s

Page A7-A8



Lo-Carbon Silent Fan  
- Up to 24l/s

Page A9-A10



Lo-Carbon VA100®/SELV  
- Up to 21l/s

Page A11-A12



Lo-Carbon Silhouette® 100/SELV  
- Up to 30l/s

Page A13-A14



Lo-Carbon Centra®/SELV  
- Up to 15l/s  
Continuous Running

Page A15-A16



NEW Lo-Carbon Revive 7/SELV  
- Up to 60l/s

Page A17-A18



Lo-Carbon Revive 5/SELV  
- Up to 60l/s

Page A19-A20



Lo-Carbon Solo® Plus/SELV  
- Up to 21l/s  
Continuous Running

Page A21-A22



Lo-Carbon Minivent  
- Up to 31l/s

Page A23



Lo-Carbon LED Vent-A-light  
- Up to 31l/s

Page A24



Lo-Carbon Quadra®  
- Up to 63l/s  
Continuous Running

Page A25-A26



Lo-Carbon Silhouette 125  
- Up to 44l/s

Page A27



Lo-Carbon VA150  
- Up to 64l/s

Page A28



Lo-Carbon Silhouette® 150  
- Up to 65l/s

Page A29

## dMEV, MEV & PIV SYSTEMS

Page B1-B24



Lo-Carbon NBR dMEV C - Up to 35l/s (126m³/h) Continuous Running

Page B3-B4



Lo-Carbon Centra®/SELV  
- Up to 15l/s (54m³/h) Continuous Running

Page B5-B6



Lo-Carbon Response 7/SELV 100  
- Up to 35l/s (126m³/h) Continuous Running

Page B7-B8



Lo-Carbon Response 7 125  
- Up to 41l/s (148m³/h) Continuous Running

Page B9-B10



Lo-Carbon Sentinel® Multivent/Plus  
- Up to 160l/s (576m³/h)

Page B11-B14



Lo-Carbon MVDC-MS/MSH Multivent  
- Up to 118l/s (425m³/h)

Page B15-B16



Lo-Carbon MVDC-MSH Uniflex Multivent  
- Up to 118l/s (425m³/h)

Page B17-B18



Lo-Carbon NBR dMEV  
- Up to 45l/s (162m³/h)

Page B19-B20



Lo-Carbon PoziDry Pro  
- Up to 50l/s (216m³/h)

Page B21-B22



Lo-Carbon PoziDry Compact Pro  
- Up to 34l/s (122m³/h)

Page B23-B24

## SINGLE ROOM dMVHR

Page C1-C12



Lo-Carbon Calido  
- Up to 25l/s (90m³/h)

Page C3-C4



Vent-Axia Lo-Carbon Heat Save  
- Up to 12l/s (43.2m³/h)

Page C5-C6



Lo-Carbon Tempra/SELV  
- Up to 15l/s (54m³/h) Continuous Running

Page C7-C8



HR200WK  
- Up to 61l/s (220m³/h)

Page C9-C10



MVHR UNITS FOR RESIDENTIAL & COMMERCIAL APPLICATIONS

Page D1-D63



Lo-Carbon Sentinel MVHR Range Overview  
- Up to 200l/s (720m<sup>3</sup>/h)  
Page D3-D6



Lo-Carbon Sentinel Econiq Passivhaus Certified  
- Up to 200l/s (720m<sup>3</sup>/h)  
Page D7-D14



Lo-Carbon Sentinel Econiq  
- Up to 200l/s (720m<sup>3</sup>/h)  
Page D15-D22



Lo-Carbon Sentinel Kinetic<sup>®</sup>  
- Up to 76l/s (274m<sup>3</sup>/h)  
Page D23-D26



Lo-Carbon Sentinel Kinetic<sup>®</sup> FH  
- Up to 93l/s (335m<sup>3</sup>/h)  
Page D27-D30



Lo-Carbon Sentinel Kinetic<sup>®</sup> Plus  
- Up to 136l/s (490m<sup>3</sup>/h)  
Page D31-D34



Lo-Carbon Sentinel Kinetic<sup>®</sup> High Flow  
- Up to 195l/s (702m<sup>3</sup>/h)  
Page D35-D38



Lo-Carbon Sentinel Kinetic<sup>®</sup> Cooker Hood  
- Up to 76l/s (274m<sup>3</sup>/h)  
Page D39-D42



Lo-Carbon Sentinel Kinetic<sup>®</sup> Horizontal  
- Up to 98l/s (353m<sup>3</sup>/h)  
Page D43-D48



Integra<sup>®</sup>  
- Up to 48l/s (173m<sup>3</sup>/h)  
Page D49-D50



Integra<sup>®</sup> Plus EC  
- Up to 130l/s (54m<sup>3</sup>/h)  
Page D51-52



HR100R/RS  
- Up to 18l/s (65m<sup>3</sup>/h)  
Page D53-D54

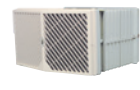

HR500  
- Up to 250l/s (900m<sup>3</sup>/h)  
Page D55-D56



HR500D  
- Up to 174l/s (626m<sup>3</sup>/h)  
Page D57-D58



HR500EP/IP  
- Up to 244l/s (878m<sup>3</sup>/h)  
Page D59-D60



HR500DP  
- Up to 333l/s (1,199m<sup>3</sup>/h)  
Page D61-D63

OVERHEATING SOLUTIONS

Page E1-E10



Lo-Carbon NBR Cool Unitary Fan  
- Up to 26l/s (94m<sup>3</sup>/h)  
Page E3-E4



NBR CoolBox Kits  
- Up to 60l/s (216m<sup>3</sup>/h)  
Page E5-E8



Lo-Carbon Sentinel Econiq CoolFlow  
- Up to 167l/s (601m<sup>3</sup>/h)  
Page E9-E16



Acoustic Residential Purge Ventilator  
- Up to 333l/s (1,199m<sup>3</sup>/h)  
Page E17-E18

DUCTING & FITTINGS

Page F1-F40

HEATING RANGE

Page G1-G8



Heated Towel Rails  
- Up to 400W  
Page G3-G4



Radiant Heaters  
- Up to 3,000W  
Page G5-G6



Lot 20 Panel Heater  
- Up to 2,000W  
Page G7



Warm Air Curtains  
- Up to 6,000W  
Page G8

# Contents

## COMMERCIAL RANGE

Page H1-H34



ACM® 100 - 200  
- Up to 240l/s  
(864m³/h)

Page H3-H4



ACM® 250 - 315  
- Up to 653l/s  
(2,351m³/h)

Page H5-H6



Powerflow  
- Up to 340l/s  
(1,220m³/h)

Page H7-H8



Lo-Carbon T-Series®  
Window Model  
- Up to 430l/s (1,550m³/h)

Page H11-H12



Lo-Carbon T-Series®  
Wall Model  
- Up to 460l/s (1,650m³/h)

Page H13-H14



Lo-Carbon T-Series®  
Roof Model  
- Up to 330l/s (1,194m³/h)

Page H15-H16



Lo-Carbon T-Series®  
Panel Model  
- Up to 490l/s (1,761m³/h)

Page H17-H18



Traditional T-Series®  
Window Model  
- Up to 449l/s (1,615m³/h)

Page H21-H22



Traditional T-Series®  
Wall Model  
- Up to 485l/s (1,745m³/h)

Page H23-H24



Traditional T-Series®  
Roof Model  
- Up to 412l/s (1,485m³/h)

Page H25-H26



Traditional T-Series®  
Panel Model  
- Up to 524l/s (1,885m³/h)

Page H27-H28



Traditional T-Series®  
Darkroom Model  
- Up to 314l/s (1,130m³/h)

Page H29-H30



Traditional T-Series®  
Inline Model  
- Up to 620l/s (2,230m³/h)

Page H31-H32



Super T-Series  
- Up to 1372l/s (4,940m³/h)

Page H33-H34

## ACCESSORIES & CONTROLLERS - RESIDENTIAL & LIGHT COMMERCIAL SYSTEMS

Page I1-I18

## PLATE & CASE FAN RANGE

Page J1-J76



Sabre Plate Mounted Sickle  
Fans (VSP)  
- Up to 5.71m³/s  
(20,556m³/hr)

Page J3-J8



Sabre Sickle Short Case Fans  
(VSC)  
- Up to 5.81m³/s  
(20,916m³/hr)

Page J9-J16



Long Case Axial  
Fans (LCA)  
- Up to 36.01m³/s  
(129,600m³/hr)

Page J17-J46



Kitchen Axial  
Fans (KAF)  
- Up to 5.93m³/s (21,348m³/  
hr)

Page J47-J50

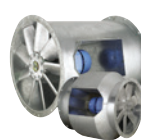

Bifurcated Case  
Axial Fans (BIFA)  
- Up to 19.10m³/s (68,760m³/  
hr)

Page J51-J76



IN-LINE FAN RANGE

Page K1-K46



<p>EuroSeries® (SDX EC) In-Line Centrifugal Fans - Up to 0.37m<sup>3</sup>/s (1,332m<sup>3</sup>/hr) Page K3-K6</p>	<p>Lo-Carbon Kitchen Box Fan (EKF) - Up to 3.69m<sup>3</sup>/s (13,284m<sup>3</sup>/hr) Page K7-K14</p>	<p>Acoustic In-Line Fans (ACQ) - Up to 1.5m<sup>3</sup>/s (5,400m<sup>3</sup>/hr) Page K15-K20</p>	<p>Eco Mix Flow Fans (eMF) - Up to 5.63m<sup>3</sup>/s (20,268m<sup>3</sup>/hr) Page K21-K26</p>	<p>Powerflow In-Line Duct Fans (ACP) - Up to 0.34m<sup>3</sup>/s (1,220m<sup>3</sup>/hr) Page K27-K30</p>	<p>EuroSeries® (SDX) In-Line Centrifugal Fans - Up to 0.35m<sup>3</sup>/s (1,260m<sup>3</sup>/hr) Page K31-K34</p>	<p>Slimpak EC Box Fan (SLP EC) - Up to 1.60m<sup>3</sup>/s (5,760m<sup>3</sup>/hr) Page K35-K40</p>	<p>Mixed Flow Fans (MFQ) - Up to 3.67m<sup>3</sup>/s (13,212m<sup>3</sup>/hr) Page K41-K46</p>
---	---	--	--	---	--	---	--

TWIN FAN RANGE

Page L1-L20

SENTINEL D-BOX

Page M1-M28



<p>Slimpak EC Twin Fan (SLPT EC) - Up to 1.37m<sup>3</sup>/s (4,932m<sup>3</sup>/hr) Page L3-L8</p>	<p>Acoustic In-Line Direct Driven Twin Fans (ATQ) - Up to 1.27m<sup>3</sup>/s (4,572m<sup>3</sup>/hr) Page L9-L14</p>	<p>Power Twin Fans (TDF) - Up to 3.52m<sup>3</sup>/s (12,672m<sup>3</sup>/hr) Page L15-L18</p>	<p>Trakmaster Twin Fan Controller Page L19-L20</p>	<p>Sentinel D-Box Single Fan - Up to 1.49m<sup>3</sup>/s (5,364m<sup>3</sup>/hr) Page M7-M16</p>	<p>Sentinel D-Box Twin Fan - Up to 1.20m<sup>3</sup>/s (4,320m<sup>3</sup>/hr) Page M17-M26</p>	<p>Sentinel D-Box Sensors &amp; Controls Page M27-M28</p>
---	---	--	--	--	---	---

SENTINEL APEX

Page N1-N18

ROOF FAN RANGE

Page O1-O20

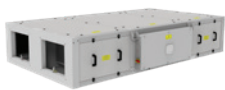

Sentinel Apex Fans  
- Up to 0.74m<sup>3</sup>/s (2,646m<sup>3</sup>/hr)  
Page N13-N18



High Temperature Roof Fans (RDM)  
- Up to 8.83m<sup>3</sup>/s (31,788m<sup>3</sup>/hr)  
Page O3-O6



Sabre® Sickle Fan Assisted Roof Cowl (VSR)  
- Up to 5.00m<sup>3</sup>/s (18,000m<sup>3</sup>/hr)  
Page O7-O14

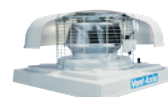

Mixed Flow Roof Fans (RMH)  
- Up to 3.63m<sup>3</sup>/s (13,068m<sup>3</sup>/hr)  
Page O15-O20

ACCESSORIES & CONTROLLERS NON-RESIDENTIAL

Page P1-P29



# Lo-Carbon Residential Fans







Continuing our commitment to energy efficiency in this section you will find Lo-Carbon solutions for intermittent and continuous fan applications.

In axial or centrifugal, wall, ceiling or window applications in bathrooms or kitchens we have a Lo-Carbon fan offering up to 90% energy saving over the equivalent traditional fan.

**Vent-Axia**<sup>®</sup>



	Vent-Axia Lo-Carbon iQ Bathroom/ Toilet Fan	A3-A4
	Vent-Axia PureAir Sense Bathroom/ Toilet Fan	A5-A6
	Lo-Carbon Svara Axial Bathroom/Toilet Fan	A7-A8
	Lo-Carbon Silent Fan Axial Bathroom/ Toilet Fan	A9-A10
	Lo-Carbon VA100®/SELV Axial Bathroom/Toilet Fan	A11-A12
	Lo-Carbon Silhouette® 100/SELV Bathroom/Toilet Fan	A13-A14
	Lo-Carbon Centra®/SELV dMEV Unit	A15-A16
	NEW Lo-Carbon Revive 7/SELV Bathroom/Kitchen Filterless Fan	A17-A18
	NEW Lo-Carbon Revive 5/SELV Bathroom/Kitchen Filterless Fan	A19-A20
	Lo-Carbon Solo Plus/SELV Centrifugal Bathroom/Toilet Fan	A21-A22
	Lo-Carbon Minivent Ducted Bath/Shower Fan Kit	A23
	Lo-Carbon LED Vent-A-light Ducted Bath/Shower Fan Kit	A24
	Lo-Carbon Quadra® Centrifugal Fan	A25-A26
	Lo-Carbon Silhouette® 125 Bathroom/Toilet Fan	A27
	Lo-Carbon VA150 Axial Kitchen & Utility Room Fan	A28
	Lo-Carbon Silhouette® 150 Axial Kitchen Fan	A29

# Lo-Carbon iQ

## Features & Benefits

- Minimal retro design to match bathroom décor
- Extremely quiet at only 21 dB(A)
- Truly surface mountable with removable spigots
- Intelligent controls and control panel for easy and flexible set up and commissioning
- Low power consumption - 2.1 - 5.5 Watts
- Easy cleaning and maintenance
- 5 year motor guarantee
- Intelligent humidistat control as standard
- Innovative airing function to ensure good air quality
- IP44 rated



### Silent Operation

The open impellor and the unique method of operating the motor enables a greater array of operating options including silent continuous ventilation along with adaptable speed control and flexible timer functions.

---

### Humidity Control

The iQ features an intelligent, fully automatic humidity sensor for moisture control. This means the fan learns to run only when it can make a difference to the indoor air quality. The fan continually monitors and records the moisture content to allow it to map the humidity profile throughout the year. This process enables the fan to ensure that it runs only when the fan can lower the moisture content in the air. This reduces nuisance running. The fan also has two modes for moisture control, silent or boost mode which can be selected via the touch pad control.

---

### Control Panel

Our aim has been for the end user to be able to control and understand the basic fan functions, without the need of reading the manual. When the fan is connected to the power supply, it also performs a self-test where all the status lamps on the control panel are tested, as well as the function of the motor. Ideal for those installing to ensure that everything works. The simple controls, along with the LED feedback make the commissioning and any readjustment, quick and easy to complete.

---

### LED Feedback

With many fans it is difficult to understand the exact mode that they are running in. We have now simplified this to provide a visual indicator to see what the fan is doing and which mode is currently active. The fan uses three different colours on the visible status lamp to communicate exactly what it is doing. A blue light signifies that the fan is working to evacuate moisture via the humidity sensor. A yellow light signifies that the timer is running. And a purple light signifies that the fully automatic airing function is active.

---

### Choose How The Fan Works

The intelligent overrun timer can be operated in several different ways, either via the light switch, integral pull-cord or a separate switch either as a standard On/Off or as a momentary switch stopping automatically after the overrun on time. Use the control panel to easily set the required post-running time at 15 or 30 minutes, depending on the choice.

---

### Full Surface Mounted Installation

With the impellor and motor assembly designed to be low profile and accessible for maintenance, spigots on the fan are completely removable. This design enables the fan to be mounted onto a wall without any spigot so that it can be truly surface mounted. This is an ideal function if there is a duct with a smaller dimension than 100 mm or a duct that bends directly off of the back of the fan not providing any depth in the wall for the spigot.

---

### Cleaning and Maintenance

For a fan to ventilate effectively, it is vital that it is kept clean and that the ductwork and grilles are free from dust that can reduce the air flowing through them. This is the first fan to be introduced with the ability to simply remove the impellor and open the centre of the fan to gain free access to the duct. Using the 'swing-out' function the fan can easily be cleaned and cleared e.g. a clogged grille on the outside of the façade. Click the button to remove the impellor, then press the snap in catch and swing out the motor - that's it!

---

### Automatic Airing Function

The airing function means when the fan has been inactive for 26 hours, it runs an airing programme for 60 minutes to exchange the air in the bathroom. No more worries about stuffy, musty odours in the bathroom when returning from holiday.

---



## Lo-Carbon 5 Year Guarantee

As there is an integrated power adapter in the fan we have been able to use a low voltage motor that has a life span of approximately 60,000 hours. This is about 3-5 times longer than a standard fan. The motor features extremely quiet bearings. By using a low voltage motor we can significantly limit power consumption. The fan only consumes 5 Watts, about a third of a conventional AC bathroom fan.

## Models

### Lo-Carbon iQ

Multi control fan with option to run on intermittent or continuous setting. Adjustable timer and humidity options with integral pullcord included.

### Model

Lo-Carbon iQ

### Stock Ref

411409

## Dimensions (mm)

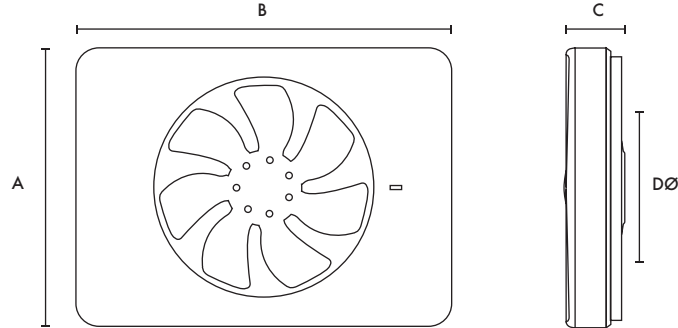

A	B	C	DØ
152	202	31	99/125

Product is supplied with a removable spigot 30mm deep in 99mmØ and 125mm Ø

## Performance

Duct Ø	Trickle/Boost	Extract Performance - FID	
		m <sup>3</sup> /h	Sound dB(A) @ 3m
100mm	Max	107	28
100mm	Silent	74	21
100mm	Trickle	42	12
125mm	Max	134	29
125mm	Silent	86	21
125mm	Trickle	55	13

# Vent-Axia PureAir Sense

- Automatic odour sensor
- 7 year warranty
- LED touch panel
- App connected
- Silent running, as low as 19dB(A)
- Low power consumption at 2.5W
- Interchangeable spigots for 100 or 125mm installations
- Easy clean with removable impeller
- Optional magnetic front cover
- IP44 Rated
- Suitable for ceiling and wall mounting



## Odour Sensor

The Vent-Axia PureAir Sense is the UK's first bathroom fan with Odour Sense Technology. This technology works by detecting unwanted odours in the air and triggers a purge function to clear the air. This results in a fresh bathroom without the need to add any harmful air sprays into the atmosphere.

## Silent Operation

Running from just 19dB(A), the PureAir Sense is whisper quiet. Its silent continuous operation enables the fan to keep the air quality in the room high, without disturbing the occupants.

## Humidity Control

The Vent-Axia PureAir Sense features an intelligent, fully automatic humidity sensor for moisture control. The fan will boost when it senses an increase in the room's humidity, ensuring the humid air is extracted and the room remains free of condensation. The fan continually monitors the environment and records the moisture content to allow it to map the humidity profile throughout the year. This process enables the fan to ensure that it runs only when the fan can lower the moisture content in the air. This reduces nuisance running and stops the fan from boosting unnecessarily, keeping running costs down.

## Touch Panel

The front of the fan includes an intuitive, easy to use LED touch panel. Users can see which fan function is active by viewing the multi-coloured LED indicator, as well as customising the fan's functions and boost speeds using the touch menu. For full description on the touch panel, please refer to the Instruction Manual provided with the fan.

## Vent-Axia Connect App

All fan settings can be customised by downloading the Vent-Axia Connect App to Android and IOS devices.



## Magnetic Front Cover

For the first time in any Vent-Axia product, a magnetic front cover is included with this fan. The cover is as simple as it sounds to put on with the use of four small magnets, and is designed to allow the fan to compliment any bathroom.



## Adjustable Timer

The adjustable overrun timer operates automatically when installed, but can be customised using the Vent-Axia Connect App. The control panel can be used to easily set the required post-running time at 15 or 30 minutes, depending on your choice.

## Cleaning and Maintenance

For a fan to ventilate effectively, it is vital that it is kept clean so that the ductwork and grilles are free from dust which can reduce the air flow. The removable impeller helps to simplify cleaning.

## Automatic Airing Function

The airing function activates when the fan has been inactive for 26 hours. It runs an airing programme for 60 minutes to exchange the air in the bathroom. No more worries about stuffy, musty odours in the bathroom when returning home from time away.

## Light Sensor

The Vent-Axia PureAir Sense is delivered factory set for continuous operation at low speed, with the fan featuring an adjustable timer that can be triggered via a switch live or light sensor. This intuitive light sensor recognises room occupancy through light movement and shadows, but can distinguish between car headlights flashes and people moving about to avoid nuisance running. A delay-on feature can also be set to avoid the fan being triggered in the night during quick bathroom visits. The light sensor also acts as an overrun timer, without having to be controlled through the light switch.



## Models

### Vent-Axia PureAir Sense

Odour Sensing fan with intelligent humidistat, adjustable timer, intermittent or continuous settings and Bluetooth app control.

Model PureAir Sense Stock Ref **479460**



### Wall Mounting Back Plate

Designed to cover up marks where a previous fan has a different foot print. 242mm x 190mm.

Model Wall Mounting Back Plate Stock Ref **406762**

## Accessories



### Internal Fit Wall Kit

Suitable for 100mm applications

Model Internal Fit Wall Kit - White Stock Ref **474779**

## Dimensions (mm)

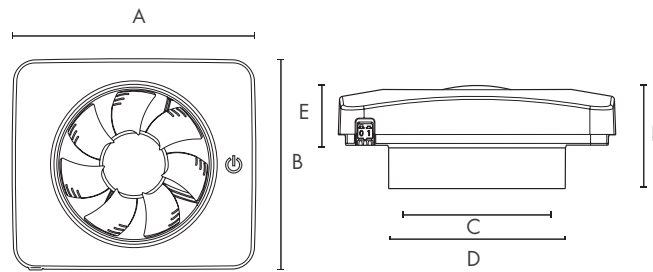

A	B	CØ	DØ	E	F
185	160	98	118	40	69

Product is supplied with a removable spigot 30mm deep for 100mmØ and 125mmØ applications. Weight 1.75kg

## Performance Guide

Duct Ø	Boost/Continuous	Extract Performance - FID		Sound dB(A)	
		m³/h	l/s	@ 3m	Watts
100mm	Max	115	32	44	5
100mm	Continuous	36	10	19	2
125mm	Max	140	39	49	5
125mm	Continuous	54	15	23	2

19dB(A) at 8l/s selectable via App

# Lo-Carbon Svara

- Multiple installation and commissioning options
- Set up and control through the App via Bluetooth
- Continuous or intermittent
- Removable impeller for easier cleaning and replacement
- Silent hours scheduling and purge mode functions
- Intelligent light sensor with overrun timer - allows replacement of a basic model fan
- 3 Speed, IP44 Rated, DC motor with 5 year warranty
- Suitable for ceiling, panel or wall mounting
- Only 17dB(A)
- Low running costs



## Fully flexible installation and control

The launch of Svara marks the next generation of unitary fans. Home owners have complete control of their indoor air through an intuitive App designed to give them flexible options on how to run the fan. Giving home owners this control has the added benefit of removing the need for multiple returns to the property post installation should the fan not be set up quite to the householders' liking. For example the humidity setting being too sensitive. The home owner can simply log on to the App and change the setting themselves.

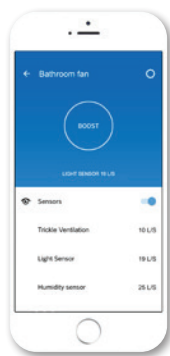

For electricians, installation is made simple through the App allowing you to choose intermittent or continuous ventilation; whether you would like the humidistat to trigger operation or not; and whether the overrun timer is required. No more fiddly switches and jumpers!



## Aesthetics and Silence

The name Svara takes its influence from the fan's Swedish heritage - a country well known for iconic and well thought out designs. Consumers will be attracted to Svara's good looks with its sleek modern design, plus with noise a key issue for consumers, households will also be impressed by Svara's quiet running, operating at just 17dB(A) on low trickle. It is also easy to clean as the central module disconnects the motor from the rest of the fan allowing it to be simply wiped with a soft cloth, and at only 4W the energy efficient Svara also boasts low power consumption.

## Multi Room Multi Function

Vent-Axia Svara is programmed to cope with the vast majority of installations. Because of this, it can be fitted in either a bathroom or Kitchen and can be set to run either continuously or intermittently.

### Light Sensor

When the light sensor is enabled Svara senses when someone is in the room and then activates. Its sophisticated light sensor is triggered by light movement and shadows. It is possible to set a delay-on so the fan is not triggered by the light during quick night time bathroom visits. The light sensor can also distinguish between headlight flashes from cars and room occupancy, so it is not triggered by passing cars, avoiding nuisance running. The sensitivity of the light sensor can be adjusted via the App.

### Overrun Timer

The light sensor provides an overrun timer but only requires a live and neutral. In houses where there is only a basic fan installed, the home owner can upgrade to a timer fan without having to rewire.

### Humidistat

Svara features a humidistat which reacts to sharp changes in humidity, for instance when someone is taking a shower. When set to continuous running, once the humidity sensor is activated the fan runs at 30l/s until humidity returns to normal levels then the fan powers down to 10l/s. Ambient humidity changes will not trigger the humidistat. It is possible to change the sensitivity of the humidity sensor via the App.

### Silent Scheduling and Automatic cycles

The silent hours scheduling function allows you to deactivate the boost function on the Svara via the App, for example, this would prevent nuisance noise overnight. Additionally during a vacation you can set Svara to an airing mode which operates a purge function every 12 hours for either 30, 60 or 90 minutes depending on selection. However, Svara's sophisticated controls, will not purge if the light sensor detects that there is someone in the house.

## Models

### Svara kitchen and bathroom fan

100 mm Axial fan. Factory set at continuous running with Humidistat and Light Sensor/overrun timer On.

Model	Stock Ref
Lo-Carbon Svara White	409802
Lo-Carbon Svara Black	496711



Model	Stock Ref
Back Draught Shutter	406605

## Accessories



Model	Stock Ref
Wall Kit	254102



Model	Stock Ref
Cover plate For duct dimensions between Ø140-160mm	
Cover Plate White	409820
Cover Plate Black	497117

## Dimensions (mm)

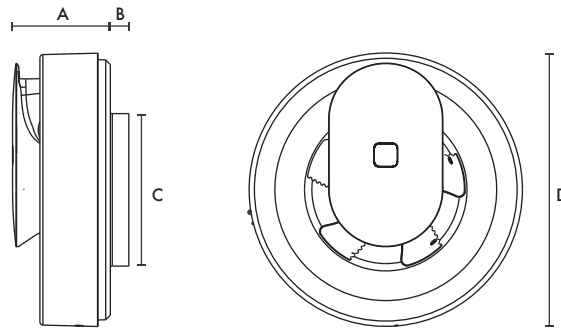

A	B	CØ	DØ
60	21	99	177

## Performance Guide

Extract Performance - FID (l/s)				Sound dB(A)	SFP (W/l/s)
Low Trickle	High Trickle	Boost	Max Watts	@ 3m	@ 0Pa
10	16	30	4	17-20	0.13



# Lo-Carbon Silent Fan

- Stylish open front models
- From only 12dB(A)
- High efficiency long life motor rated up to 40,000 hours run time
- 5 year warranty
- IPX5 - Zone 1 rated
- Meets current Building Regulations Approved Document F and L
- Extra-long duct run? Variable speed adjustment at installation allows you to get the airflow you need
- Closed or open fronted models
- Silent bathroom fan with intermittent and continuous running options
- Back draught shutters included
- Suitable for wall, ceiling, window and panel mounting



## Lo-Carbon Silent Fan Axial Bathroom/Toilet Fan

The Lo-Carbon Silent Fan Range from Vent-Axia not only delivers stylish and silent ventilation without compromise on performance, but now comes with even more features and more model options providing flexibility when choosing the right fan.

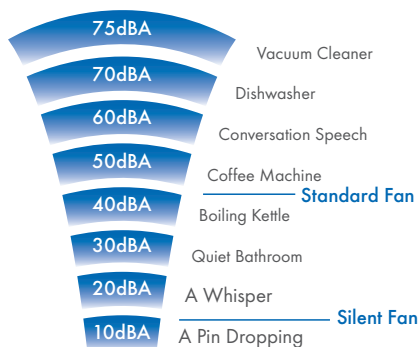

### Models

#### Zone 1 Variable Speed, Intermittent

Remote or light switch operation. Variable speed options selectable at install. Intermittent operation.

Model	Stock Ref
VASF100BV (closed grille)	479085
VASF100BVO (open grille)	495700

#### Zone 1 Variable Speed, Intermittent, Timer

Intermittent Operation. Fixed 15 min overrun timer. Variable speed options selectable at install.

Model	Stock Ref
VASF100TV (closed grille)	479086
VASF100TVO (open grille)	495701

#### Zone 1 Variable Speed, Intermittent, Humidity Timer

Intermittent Operation. Humidity controlled with fixed 15 min timer overrun. Variable speed options selectable at install.

Model	Stock Ref
VASF100HTV (closed grille)	479087
VASF100HTVO (open grille)	495702

#### Zone 1 Variable Speed, Continuous, Timer

Fixed 15 min overrun timer. Continuous running fan with variable speed selectable at install.

Model	Stock Ref
VASF100TC (closed grille)	479088
VASF100TCO (open grille)	495703

#### Zone 1 Variable Speed, Continuous, Humidity Timer

Humidity controlled with fixed 15 min timer overrun. Continuous running fan with variable speed selectable at install.

Model	Stock Ref
VASF100HTC (closed grille)	479089
VASF100HTCO (open grille)	495704

### Accessories

Model	Stock Ref
Window Kit	442947
Wall Kit White	254102
Wall Kit Brown	254100
Internal Fit Wall Kit White + Backdraught Shutter	474779

## Dimensions (mm)

Closed Grille

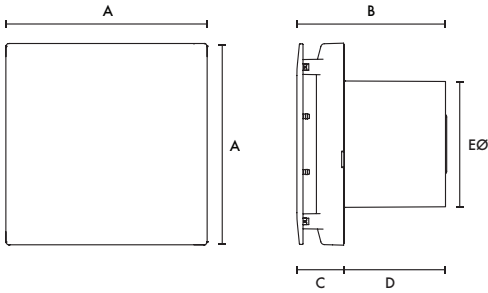

Open Grille

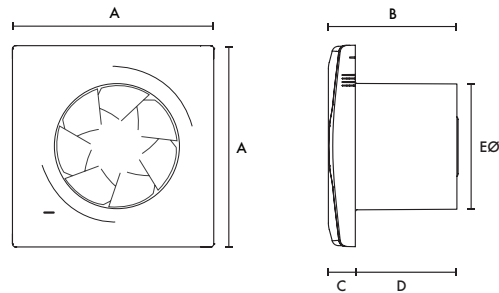

Grille	A	B	C	D	EØ
Closed	160	117	37	80	99
Open	160	117	22	80	99

Weight 0.7kg

## Performance Guide

Closed Grille

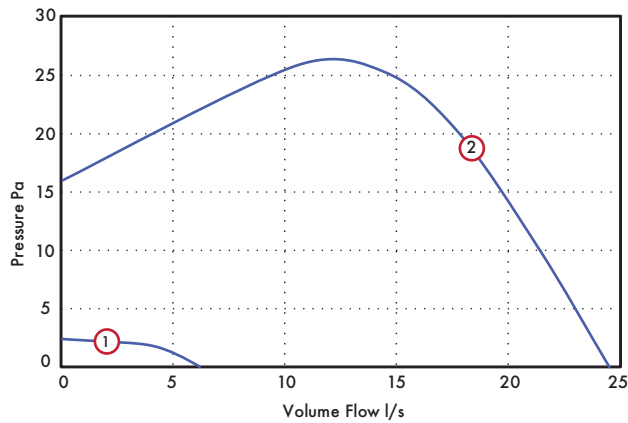

Open Grille

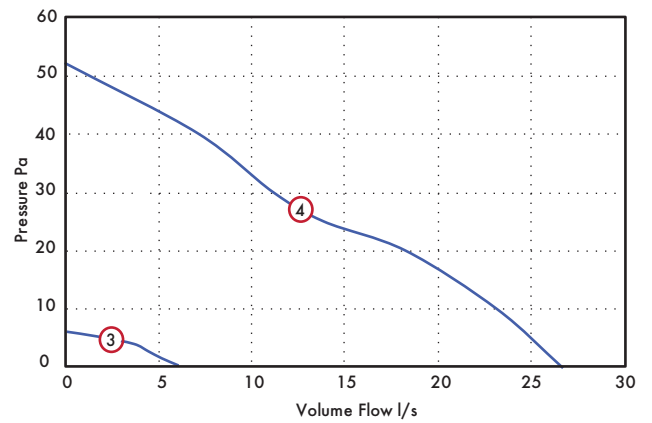

	Model	Speed	l/s	Watts	Warranty (years)
Variable Speed	VASF100BV/ TV/HTV	① Min	6	1.7	5
		② Max	24	7.5	
	VASF100TC/ HTC	Adjustable	6 - 15	1.7 - 7.5	5
		Trickle			
		Boost	Adjustable Trickle + 10 (Up to a max of 24 installed)	7.5	

12dB(A) - Sound dB(A) @3m at low speed

	Model	Speed	l/s	Watts	Warranty (years)
Variable Speed	VASF100BVO/ TVO/HTVO	③ Min	6	1.7	5
		④ Max	27	7.5	
	VASF100T- CO/HTCO	Adjustable	6 - 19	1.7 - 7.5	5
		Trickle			
		Boost	Adjustable Trickle + 10 (Up to a max of 24 installed)	7.5	

12dB(A) - Sound dB(A) @3m at low speed

# Lo-Carbon VA100/SELV

- Meets current Building Regulations Approved Document F & L
- Suitable for wall, ceiling, panel and window mounting
- Fitted with a motorised shutter
- Protected against low energy lighting circuits
- IPX4 rated - IPX7 rated (SELV)
- Efficient long life DC motor with 5 year warranty
- Uses up to 87% less energy
- Low sound levels
- 1 of 2 speeds selectable at installation
- Low specific fan power



## Long Life Ventilation VA100

The Vent-Axia Lo-Carbon VA100 range features Lo-Carbon long life DC motors that are more efficient than conventional motors delivering up to 87% energy savings.

## Shutters

The Vent-Axia Lo-Carbon VA100 range is fitted with a motorised shutter mechanism that uses no extra power in operation or off.

## Installation

Fitted with integral protection against low energy lighting circuits, the Lo-Carbon VA100 is a 100mm axial fan suitable for use in the bathroom or toilet. VA100 is quick and simple to fit with easy-wire in one line terminals. Suitable for installation in windows, walls or panels/ceilings using kits available. The 100mm telescopic wall kit fits walls 225 to 360mm thick. The range meets the requirements of the current Building Regulations for the ventilation of toilets 6l/s and bathrooms 15l/s with a 15 minute overrun timer for internal rooms on the LT, XT and HTP models.

## Safety Extra Low Voltage (SELV) Fan

Safety Extra Low Voltage (SELV) is designed for areas where a fan has to be fitted within zone 1 in a room containing a fixed bath or shower according to IEE wiring regulations. The VA100 SELV can be safely installed within the spray area. The fan is rated IPX7, control is by the supplied mains safety isolating transformer with 12V DC SELV output, which is sited away from any source of spray and out of reach of a person using a fixed bath or shower.

## Models

### Lo-Carbon VA100 LP/SELV LP (Pullcord)

Ultra long life DC motor. Pullcord On/Off override switch with indication light. 2 speed options.

Model	Stock Ref
LP	443159
SELV LP	441614A

### Lo-Carbon VA100 XP/SELV XP (Shutter/Pullcord)

Ultra long life DC motor. Pullcord and On/Off override switch with indication light. 2 speed options.

Model	Stock Ref
XP	443160
SELV XP	459049A

### Lo-Carbon VA100 LT/SELV LT (Timer)

Electronic adjustable overrun timer (5-30 minutes). Indication light. 2 speed options.

Model	Stock Ref
LT	443161
SELV LT	441615A

### Lo-Carbon VA100 XT/SELV XT (Shutter/Timer)

Integral electronic adjustable overrun timer (5-30 minutes). Indication light. 2 speed options.

Model	Stock Ref
XT	443162
SELV XT	459050A

### Lo-Carbon VA100 LHTP/SELV LHTP (Integral Humidity Sensor/Pullcord/Timer)

Complete with integral humidity control with pullcord override. Indication light which operates on the manual override only. 2 speed options.

Model	Stock Ref
LHTP	443163
SELV LHTP	441616A

### Lo-Carbon VA100 XHTP/SELV XHTP (Shutter/Integral Humidity Sensor/Pullcord/Timer)

Complete with integral humidity control with pullcord override. Indication light which operates on the manual override only. IPX4 rated. 2 speed options.

Model	Stock Ref
XHTP	443164
SELV XHTP	436064A

## Accessories

### Wall Kit

Fixing hole diameter 117mm $\varnothing$

Model Stock Ref

Wall Kit White 254102

Wall Kit Brown 254100

### Window Kit

Fixing hole diameter 105mm $\varnothing$

Model Stock Ref

Window Kit 254101

Anti-tamper Window Kit 443234

## Dimensions (mm)

Panel

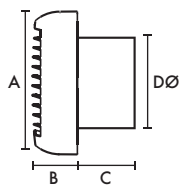
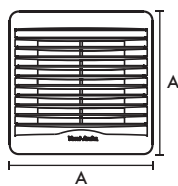

Wall

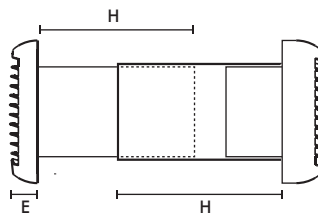

Window

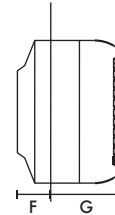

Area	A	B	C	DØ	E	F	G	H
Bathroom/Toilet	146	47	53	98	31	31	74	200

SELV Transformer (W x H x D) 87 x 87 x 33

Weight 1 kg

## Performance

Area	Models	Extract Performance - FID			Sound dB(A)	SFP (W/l/s)
		m <sup>3</sup> /h	l/s	Watts	@ 3m	@ 0Pa
Toilet	Lo-Carbon VA100/SELV LP/XP/LHTP/XHTP/LT/XT	60	17	3.4	32	0.20
Bathroom	Lo-Carbon VA100/SELV LP/XP/LHTP/XHTP/LT/XT	74	21	7.0	36	0.33



# Lo-Carbon Silhouette 100/SELV

- Models Basic/Timer/Humidity & Timer
- Low power consumption - Lower running costs
- Fully opening and closing non-transparent shutters - Improved insulation and privacy
- Meets current Building Regulations Approved Document F & L
- 1 of 2 speeds selectable at installation
- Blue power indication light (except B model) - Modern aesthetics
- Ball bearing motors for vertical or horizontal application
- Unique humidity sensor track - Improved response
- 5 year motor warranty
- IPX4 rated - IPX7 rated (SELV)
- Suitable for wall, ceiling, panel and window mounting



## Slimline Bathroom Ventilation

With a slim profile of only 17mm, Lo-Carbon Silhouette blends in with the wall surface to provide an unobtrusive installation. Lo-Carbon Silhouette has an FID performance of up to 30l/s. It can be ceiling/panel mounted and connected to an appropriate duct run to the outside.

## Safety Extra Low Voltage (SELV) Fan

Safety Extra Low Voltage (SELV) is designed for areas where a fan has to be fitted within zone 1 in a room containing a fixed bath or shower according to IEE wiring regulations. The Silhouette SELV can be safely installed within the spray area. The Silhouette SELV, control is by the supplied mains safety isolating transformer with 12V DC SELV output, which is sited away from any source of spray and out of reach of a person using a fixed bath or shower. SELV transformer to BS EN 60742.

## Models

### Lo-Carbon Silhouette 100B/SELV 100SVB

100mm bathroom/toilet fan with back draught shutter.

Model	Stock Ref
100B	441624
SELV 100SVB	441511A

### Lo-Carbon Silhouette 100T/ SELV 100SVT (Timer)

100mm bathroom/toilet fan with integral adjustable electronic overrun timer (5-30 minutes), indicator light which operates on manual override only, and back draught shutter.

Model	Stock Ref
100T	441625
SELV 100SVT	441512A

### Lo-Carbon Silhouette 100HT (Humidistat/Timer)

100mm bathroom/toilet fan with adjustable auto humidity sensor from 60-90% RH and overrun timer, indicator light which operates on manual override only, and back draught shutter.

Model	Stock Ref
100HT	441626

### Lo-Carbon Silhouette 100H SELV (Humidistat)

100mm bathroom/toilet fan with ambient response humidity sensor from 60-90% RH, indicator light which operates on manual override only, and back draught shutter.

Safety Extra Low Voltage version.

Model	Stock Ref
SELV 100SVH	441513A

## Accessories

### Wall Kit

Fixing hole diameter 117mmØ

Model	Stock Ref
Wall Kit White	254102
Wall Kit Brown	254100

### Window Kit

Fixing hole diameter 117mmØ

Model	Stock Ref
Window Kit	442947



17mm actual profile

## Dimensions (mm)

Panel

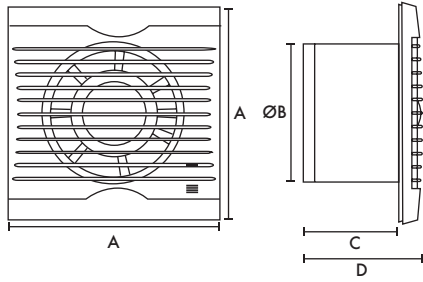

Wall Kit

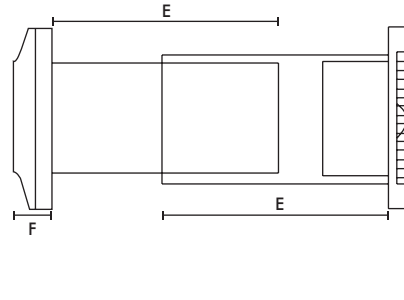

A	ØB	C	D	E	F
160	99	115	132	200	32

SELV Transformer (W X H X D) 87 X 87 X 33

Weight 0.6kg

## Performance Guide

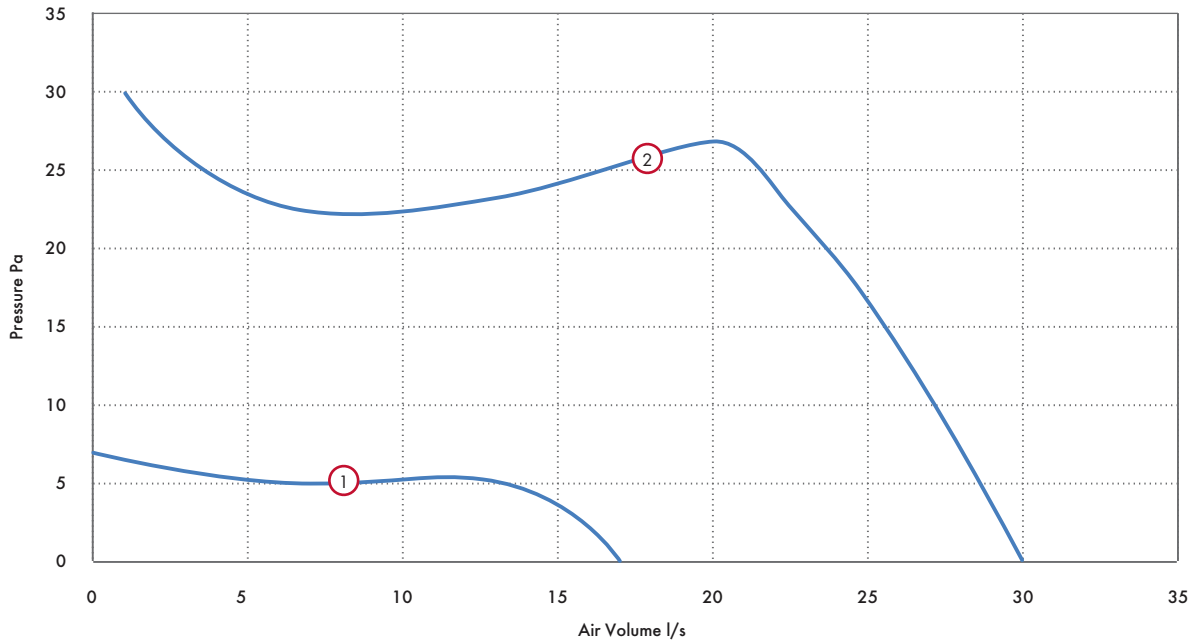

Area	Model	Curve Ref	Extract Performance - FID			Sound dB(A)	SFP (W/l/s)
			m <sup>3</sup> /h	l/s	Watts	@ 3m	@ OPa
Toilet	Lo-Carbon Silhouette 100 B/T/HT/SVB/SVT/SVH	1	60	17	3.4	34	0.20
Bathrooms		2	108	30	8.7	38	0.30

For window mounting: shutter cannot be used and must be removed

# Lo-Carbon Centra/SELV

- Building Regulations Approved Documents F and L compliant
- Continuous mechanical extract
- Discreet, tasteful styling
- IPX4 rated - IPX7 rated (SELV)
- dMEV Pressure detection device
- 5 year motor warranty
- Suitable for wall, ceiling, panel and window mounting
- SELV models supplied with remote transformer and suitable for 'Zone 1'



## What is de-centralised MEV (dMEV)?

Building Regulations Approved Document F gives examples of three main methods of ventilation. Continuous mechanical extract ventilation, can be achieved using a single centralised extract unit such as the Sentinel Multivent ducted to 'wet' rooms (kitchen, bathroom, en-suite and WC) or by decentralised individual fans, such as the Lo-Carbon Centra in the 'wet' rooms. The fans run continuously at near silent levels providing a simple and effective form of ventilation.

SELV (Safety Extra Low Voltage) is designed for areas where a fan can be installed within Zone 1 in a room where there is a fixed bath or shower. Ingress Protected (IP) to IPX7 Lo-Carbon Centra SELV can be fitted safely within the spray area. The separate transformer can be mounted away from the spray zone and out of reach from the bath or shower.

The Lo-Carbon Centra meets the latest requirements of the Building Regulations Approved Document F for wholehouse system ventilation and all models come with a 5 year motor warranty.

Selection of the two trickle flow rates (6l/s or 9l/s) is via a simple 'jumper' on the control board. Different methods are available for operating the 15 l/s boost speed from a simple switched live to integral humidistat. See individual models for further details.

The attractive and discreet styling of the Vent-Axia Lo-Carbon Centra will complement the décor of any new home while virtually silent operation ensures optimum ventilation is achieved without intrusive noise.

---

## Specific Fan Power

Lo-Carbon Centra has a specific fan power of only 0.18 W/l/s in through-the-wall kitchen applications.

---

## Models

### Lo-Carbon Centra dMEV

Auto speed selection at installation and suitable for bathrooms or kitchens. The integral air pressure sensor checks the airflow when first installed and also helps the fan to compensate for external wind pressure.

#### Stock Ref

**441782B**

### Lo-Carbon Centra T/SELV T (Timer)

Ideal for bathroom and toilet applications, this unit runs continuously on trickle setting and may be boosted by the switched live input which activates the timer (fixed 15 min on T models, adjustable 5-30 minutes on SELV models).

#### Model

#### Stock Ref

T

**473825**

SELV T

**443175A**

### Lo-Carbon Centra TP/SELV TP (Timer/Pullcord)

For bathroom/toilet applications, the continuous running TP model is boosted by the pullcord which activates the timer (fixed 15 min on TP models, adjustable 5-30 minutes on SELV models).

#### Model

#### Stock Ref

TP

**473826**

SELV TP

**447128A**

### Lo-Carbon Centra HT/SELV HT (Humidistat/Timer)

For bathroom/toilet applications, the continuous running HT model is automatically boosted by the built-in humidistat or by a switched live input which activates the timer (fixed 15 min on HP models, adjustable 5-30 minutes on SELV models).

#### Model

#### Stock Ref

HT

**473827**

SELV HT

**443176A**

### Lo-Carbon Centra HTP/SELV HTP (Humidistat/Timer/Pullcord)

For bathroom/toilet applications, the continuous running HTP model is automatically boosted by the built-in humidistat or by the pullcord which activates the timer (fixed 15 min on HTP models, adjustable 5-30 minutes on SELV models).

Model	Stock Ref
HTP	473828
SELV HTP	443177A

### Dimensions (mm)

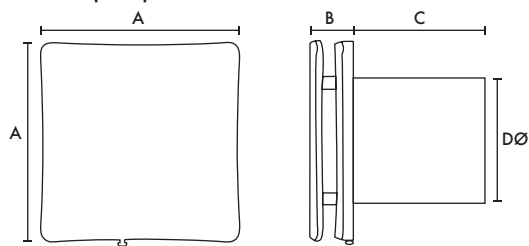

Model	A	B	C	DØ
Lo-Carbon Centra dMEV/All SELV	160	35	115	99
Lo-Carbon Centra T/TP/HT/HTP	160	35	115	99

Transformer 87 x 87 x 33mm (W x H x D) (SELV models only)

### Accessories

Model	Stock Ref
150mm Conversion Kit	443334
Wall Kit White	254102
Wall Kit Brown	254100
Window Kit	442947
Ceiling Kit	443800

### Performance Guide

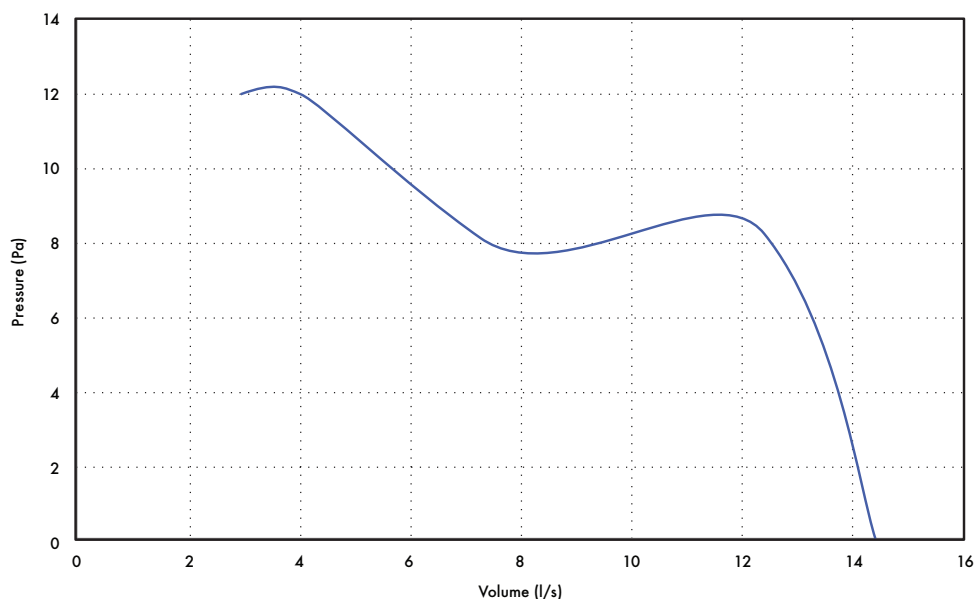

Model	Extract Performance (l/s)			Power Consumption (Watts)			Sound dB(A)@ 3m		
	Trickle	Trickle	Boost	Trickle	Trickle	Boost	Trickle	Trickle	Boost
	Low	High		Low	High		Low	High	
Lo-Carbon Centra dMEV/All SELV	6	9	15	1.4	1.6	2.4	10.8	15.5	25.2
Lo-Carbon Centra T/TP/HT/HTP	6	9	15	3.2	3.5	4.2	10.8	15.5	25.2



# NEW Lo-Carbon Revive 7/SELV

- Designed to exceed the needs of Social Housing
- Continuous running bathroom and kitchen fan
- 7 year warranty
- High performance on trickle to avoid going to boost too often
- Small footprint with optional decoration frame
- Slimmer profile, making it suitable for window installations
- Unique lock settings to prevent tampering
- Humidity, timer and pullcord functions included (HTP)
- Innovative Multi-Vortex technology ensures high performance with improved sound and energy levels
- Intelligent Smart Sense™ data logging technology tells you days run, boost hours run, energy used



## Designed for Social Housing

The new and improved Lo-Carbon Revive 7 is a filter-less unitary fan designed to meet the specific needs of social housing. Boasting powerful, quiet, efficient ventilation, Revive 7 provides good indoor air quality and comfort for residents while being quick and easy to install, low maintenance and reliable.

## Smart Sense™ Technology

Featuring Smart Sense™ intelligent technology, Revive 7 is quick and easy to install due to its simple alpha numeric LED display which is clear, easy to read and has a three-button menu for commissioning and data gathering. Smart Sense™ technology even tells the LED display which orientation to use depending on whether it is wall or ceiling mounted. All of which saves time on site and reduces installation complications. The Revive 7 is the only fan in the market with a unique lock setting to prevent tampering with the unit, giving the landlords peace of mind.

The display also shows real-time data so landlords can reassure residents of the low-running costs. This includes data such as days run, hours on trickle or boost, and even more specifically, hours run on boost triggered by the humidity sensor. Revive 7 can also tell you how much energy the fan has used.

## Multi-Vortex™ Technology

Revive 7 is low maintenance since its market-leading Multi-Vortex™ technology does not require a filter, while the highly sculpted interior actively repels dust, avoiding clogging, helping to avoid call backs. In addition the Multi-Vortex™ technology has a high-pressure hybrid impeller that is powerful and efficient, yet quiet - everything you need for the social housing resident.

## Multiple configuration options

Revive 7 can extract up to 60l/s from a kitchen - just two fans can exceed Part F rates for a three bed house. Upon installation you have the choice to change the setting to allow for installation in a bathroom and kitchen. The installer can also choose between ducted or through the wall to ensure the fan performs as intended regardless of install method. All selected via the intuitive LED display.

## Intelligent Humidity Sensing and Controls

It is essential to capture moisture at the source before it can migrate throughout the entire property. However, over-ventilating with crude humidity controls can cause excessive noise and discomfort to the resident. The Lo-Carbon Revive 7 range utilises advanced humidity controls which boost in line with the detected humidity levels and whether they are rising or declining. This allows it to effectively deal with moisture, while minimising noise.

## Models

### NEW Lo-Carbon Revive 7/SELV 7

A universal kitchen or bathroom HTP fan with options to be continuous running or intermittent. Adjustable trickle speed between 6-16l/s and boost speeds of 18, 30 and 60l/s. Day logger and power run meter as standard. 7 year warranty. Built-in lock function. Adjustable dynamic ambient response humidity sensor. Timer adjustable between 1 and 30 minutes. In built boost activated by pullcord, humidity sensor, switched live or remote button. Tile front for discreet installation.



Model	Stock Ref
Lo-Carbon Revive 7	473848A
Lo-Carbon Revive SELV 7	473849A

## Accessories

Model	Stock Ref
Wall Kit White	254102
Wall Kit Brown	254100
Conversion Kit	408680
Ceiling Kit	407928
Window Kit	407927
Decoration Frame	474041

## Dimensions (mm)

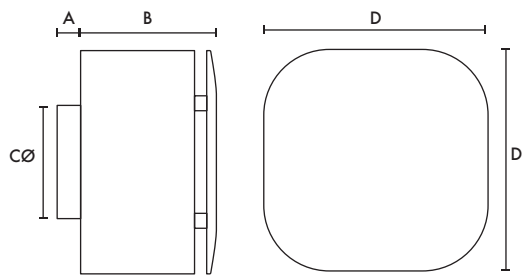

A	B	CØ	D
30	115	99	193

## Decoration Frame Dimensions (mm)

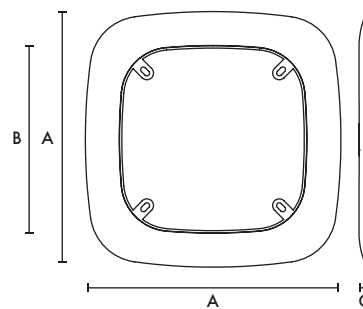

A	B	C
259	191	10

## Performance Guide

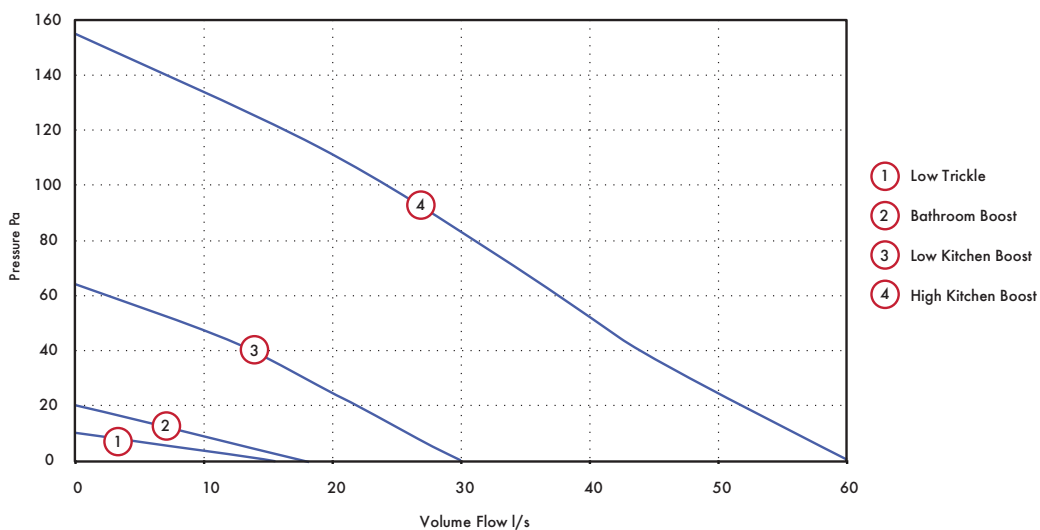

Extract Performance (l/s)				Power Consumption (Watts)				Sound Data (dB(A))			
Trickle Low	Bathroom Boost	Low Kitchen Boost	High Kitchen Boost	Trickle Low	Bathroom Boost	Low Kitchen Boost	High Kitchen Boost	Trickle Low	Bathroom Boost	Low Kitchen Boost	High Kitchen Boost
6*	18	30	60	1.4	2	6	19	11	18	33	46

\*Can be adjustable between 6 and 16 l/s

# NEW Lo-Carbon Revive 5/SELV

- Designed to exceed the needs of Social Housing
- Continuous running bathroom and kitchen fan
- 5 year warranty
- High performance on trickle to avoid going to boost too often
- Small footprint with optional decoration frame
- Slimmer profile, making it suitable for window installations
- Unique lock settings to prevent tampering
- Humidity, timer and pullcord functions included (HTP)
- Innovative Multi-Vortex technology ensures high performance with improved sound and energy levels
- Intelligent Smart Sense™ data logging technology tells you days run, boost hours run, energy used



## Designed for Social Housing

The new and improved Lo-Carbon Revive 5 is a filter-less unitary fan designed to meet the specific needs of social housing. Boasting powerful, quiet, efficient ventilation, Revive 5 provides good indoor air quality and comfort for residents while being quick and easy to install, low maintenance and reliable.

## Smart Sense™ Technology

Featuring Smart Sense™ intelligent technology, Revive 5 is quick and easy to install due to its simple alpha numeric LED display which is clear, easy to read and has a three-button menu for commissioning and data gathering. Smart Sense™ technology even tells the LED display which orientation to use depending on whether it is wall or ceiling mounted. All of which saves time on site and reduces installation complications. The Revive 5 is the only fan in the market with a unique lock setting to prevent tampering with the unit, giving the landlords peace of mind.

The display also shows real-time data so landlords can reassure residents of the low-running costs. This includes data such as days run, hours on trickle or boost, and even more specifically, hours run on boost triggered by the humidity sensor. Revive 5 can also tell you how much energy the fan has used.

## Multi-Vortex™ Technology

Revive 5 is low maintenance since its market-leading Multi-Vortex™ technology does not require a filter, while the highly sculpted interior actively repels dust, avoiding clogging, and helping to avoid call backs. In addition, the Multi-Vortex™ technology has a high-pressure hybrid impeller that is powerful and efficient, yet quiet - everything you need for the social housing resident.

## Multiple configuration options

Revive 5 can extract up to 60l/s from a kitchen - just two fans can exceed Part F rates for a three bed house. Upon installation, you have the choice to change the setting to allow for installation in a bathroom and kitchen. The installer can also choose between ducted or through the wall to ensure the fan performs as intended regardless of install method. All are selected via the intuitive LED display.

## Intelligent Humidity Sensing and Controls

It is essential to capture moisture at the source before it can migrate throughout the entire property. However, over-ventilating with crude humidity controls can cause excessive noise and discomfort to the resident. The Lo-Carbon Revive 5 range utilises advanced humidity controls which boost in line with the detected humidity levels and whether they are rising or declining. This allows it to effectively deal with moisture, while minimising noise.

## Models

### Lo-Carbon Revive 5/SELV 5

A universal kitchen or bathroom HTP fan with options to be continuous running or intermittent. Adjustable trickle speed between 6-16l/s and boost speeds of 18, 30 and 60l/s. Day logger and power run meter as standard. 5 year warranty. Built-in lock function. Adjustable dynamic ambient response humidity sensor. Timer adjustable between 1 and 30 minutes. In built boost activated by pullcord, humidity sensor, switched live or remote button. Open front grille.

Model	Stock Ref
Lo-Carbon Revive 5	473850A
Lo-Carbon Revive SELV 5	473851A



### Lo-Carbon Revive/SELV

A universal kitchen or bathroom HTP fan with options to be continuous running or intermittent. Adjustable trickle speed between 6-16l/s and boost speeds of 18, 30 and 60l/s. 5 year warranty. Adjustable dynamic ambient response humidity sensor. Timer adjustable between 1 and 30 minutes. In built boost activated by pullcord, humidity sensor, switched live or remote button. Open front grille.

Model	Stock Ref
Lo-Carbon Revive	473852A
Lo-Carbon Revive SELV	473853A





## Accessories

Model	Stock Ref
Wall Kit White	254102
Wall Kit Brown	254100
Conversion Kit	408680
Ceiling Kit	407928
Window Kit	407927
Decoration Frame	474041

## Dimensions (mm)

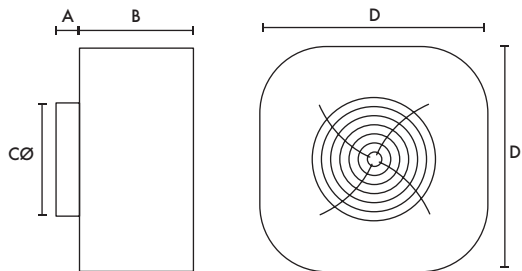

A	B	CØ	D
30	88	99	193

## Decoration Frame Dimensions (mm)

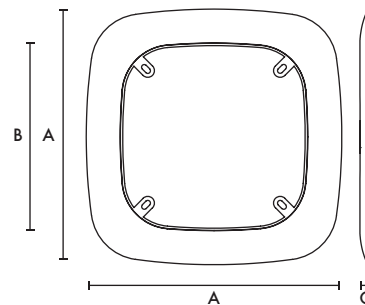

A	B	C
259	191	10

## Performance Guide

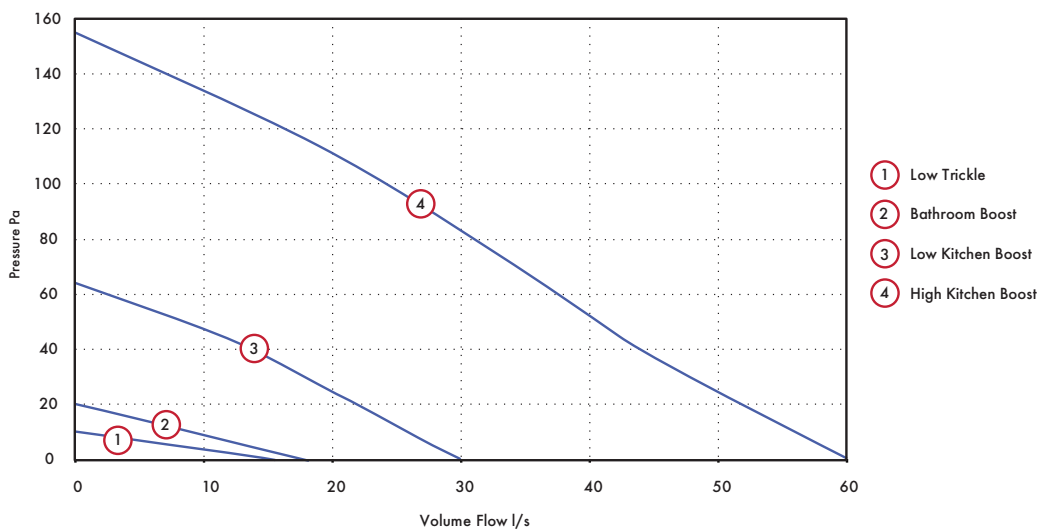

Trickle Low	Extract Performance (l/s)			Trickle Low	Power Consumption (Watts)			Trickle Low	Sound Data (dB(A))		
	Bathroom Boost	Low Kitchen Boost	High Kitchen Boost		Bathroom Boost	Low Kitchen Boost	High Kitchen Boost		Bathroom Boost	Low Kitchen Boost	High Kitchen Boost
6*	18	30	60	1.4	2	6	19	11	18	33	46

\*Can be adjustable between 6 and 16 l/s

# Lo-Carbon Solo Plus/SELV

- Up to 70% energy saving
- Filterless as standard - innovative impeller design means no need for a filter
- 5 year Lo-Carbon motor warranty
- Meets current Building Regulations Approved Documents F & L
- IPX4 rated - IPX7 rated (SELV)
- Flush or surface mountable with adjustable rear or side exit spigot
- SELV models suitable for installation over or within reach of a shower or bath
- Extremely low sound levels
- Suitable for wall, ceiling and panel mounting
- SELV Models - Supplied with a remote transformer



## Long Life Ventilation

The Lo-Carbon Solo Plus range from Vent-Axia has been specially designed for through the wall and ducted applications, suitable for internal bathrooms, toilets and other small rooms. Finished in white, the Lo-Carbon Solo Plus can be flush or surface mounted, with a 2 position 100mm circular spigot for rear entry or connecting to a vertical ducting system. The powerful centrifugal impeller allows installations using 100mm ducting in straight runs, whilst still achieving 15l/s as required by Building Regulations Approved Document F.

Continuous running products, such as the Lo-Carbon Solo Plus, installed in all wet areas of a dwelling are classed as a wholehouse ventilation system and therefore only need to move the amount of air as outlined in table 5.1a and 5.1b of Building Regulations Approved Document F.

The Lo-Carbon Solo Plus has an adjustable boost speed which is set at installation variable between a wall or duct setting for boost/override operation to meet Building Regulations thus ensuring minimum energy usage and low sound levels. All models have an optional speed for constant trickle ventilation (12l/s), selectable at installation. Depending on the model, the fan will switch from trickle (if selected) to boost via the pullcord/light switch/humidity sensor/PIR.

All models can be wall, panel or ceiling mounted and can be connected to either circular, rectangular or Vent-Axia's flat ducting. Enclosure of the electrical components is manufactured from flame retardant grade material.

## Safety Extra Low Voltage Fan (SELV)

Designed for areas where a fan has to be fitted over or within Zone 1 in a room containing a fixed bath or shower according to IEE wiring regulations (BS 7671), the Lo-Carbon Solo Plus SELV fan can be safely installed within the spray area. The fan is rated IPX7. Control is by the supplied mains safety isolating transformer unit with 12V DC SELV output, which is sited away from any source of spray and out of reach of a person using a fixed bath or shower. Controller Supply voltage 220-240V/1/50Hz. Output to fan SELV 12V DC.

## Models

### Lo-Carbon Solo Plus P/SELV P (Pullcord)

Flush or surface mountable. Control by Pullcord. 2 Speed. Constant trickle option. Adjustable boost. In-built Lo-Carbon controller.

Model	Stock Ref
P	427481B
SELV P	427485B

### Lo-Carbon Solo Plus T/SELV T (Timer)

Flush or surface mountable. Control by room light or switch. 2 Speed. Constant trickle option. Adjustable boost. Adjustable timer overrun. Delay on timer. In-built Lo-Carbon controller.

Model	Stock Ref
T	427482B
SELV T	427486B

### Lo-Carbon Solo Plus HT/SELV HT (Humidistat/Timer)

Flush or surface mountable. Humidity controlled fan with override pullcord. Constant trickle option. Adjustable boost. Adjustable timer overrun. Delay on timer. Adjustable humidity sensor. In-built Lo-Carbon controller. Datalogger as standard on all Lo-Carbon humidity controlled Solo Plus fans.

Model	Stock Ref
HT	427483B
SELV HT	427487B

### Lo-Carbon Solo Plus TM/SELV TM (Timer/PIR)

Flush or surface mountable. Control by integral PIR detector. 2 Speed. Constant trickle option. Adjustable boost. In-built Lo-Carbon controller.

Model	Stock Ref
TM	427484B
SELV TM	427488B

## Accessories

### Lo-Carbon Solo Plus Bezel

Used when flush mounting - reduces the need to make good.

Model Stock Ref  
 Bezel 404106

Model Stock Ref  
 Wall Kit White 254102  
 Wall Kit Brown 254100

### Filter Pack (1 per pack)

The design of the Lo-Carbon Solo Plus means that it does not need a filter. However, if you are going to install the product in a heavily greasy environment, you may want to protect the product by fitting a filter.

Model Stock Ref  
 Filter Pack 449265

## Dimensions (mm)

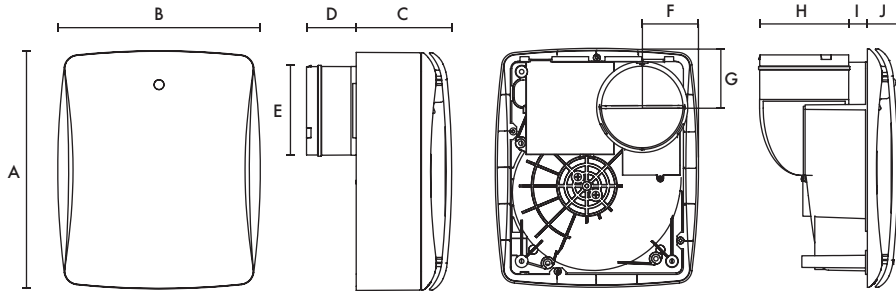

A	B	C	D	EØ	F	G	H	I	J
263	224	106	55	98	62	65	98	21	34

Weight 2.2kg, SELV Weight 2.7kg. Dimensions: (W x H x D) 87x87x33mm.

## Performance Guide (Duct Mode)

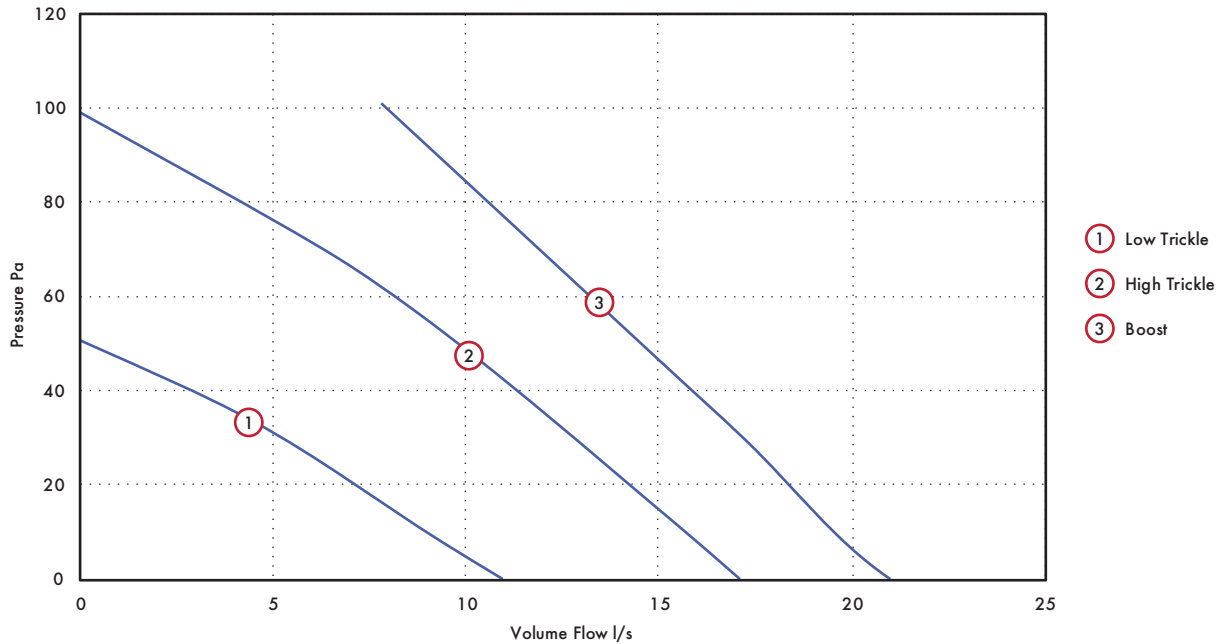

Model		Extract Performance l/s (m³/h)			Power consumption - Watts			dB(A) @ 3m			SFP (W/l/s) @ 0Pa
		Boost	High trickle	Low Trickle	Boost	High trickle	Low Trickle	Boost	High trickle	Low Trickle	
Lo-Carbon Solo Plus/SELV P/T/HT/TM	Wall mode	18 (64.8)	12 (43.2)	8 (28.8)	6	2.9	2.3	33.5	27	23.5	0.28
	Duct mode	21 (75.6)	17 (61.2)	11 (39.6)	8.4	5.3	3.2	35.5	33	26	0.29

Tested at 240VAC @ 50Hz

# Lo-Carbon Minivent

- Complete kit supplied
- Meets Building Regulations Approved Document F & L requirements for toilets and bathrooms at max 1.5m of ducting and 1x 90° bend
- Adjustable timer version available
- 5 year Motor Warranty
- 1 of 2 speeds selectable at installation



## Powerful Lo-Carbon In-Line Fan Kit

The Vent-Axia Lo-Carbon Minivent ducted bath/shower kit includes all the components necessary to install a ducted 100mm system. This simplifies fitting of an efficient ventilation system to small rooms including bathrooms, shower rooms and toilets. It is especially suitable for en-suite bathrooms.

Lo-Carbon Minivent Shower Kit installed

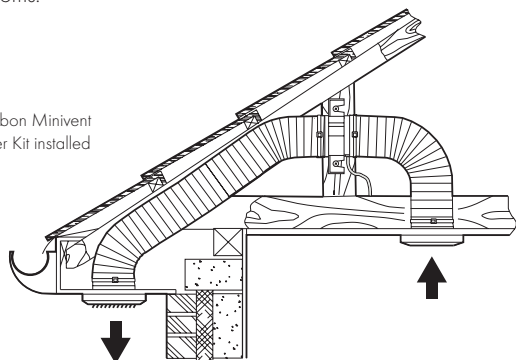

When installed, the fan kit has ample performance to meet the Building Regulations requirements for toilets and bathrooms. The timer version should be used for internal rooms.

The kit consists of a Lo-Carbon Minivent In-Line fan, a white ceiling grille and spigot, 3 metres of flexible duct and an external louvre for soffit or wall mounting. The duct should be cut to the required length and the bend radius kept to a maximum to provide optimum fan performance.

Enclosed terminal compartment, Class 2 appliance. Supply voltage 220-240/1/50Hz.

## Models

### Lo-Carbon Minivent Shower Fan (Basic)

Comprises - high output tube fan, 3 metres of flexible duct, ceiling inlet grille and spigot, soffit/wall outlet grille.

**Model** Stock Ref  
**Basic** 441421A

### Lo-Carbon Minivent Shower Fan (Timer)

Comprises high output tube fan, 3 metres of flexible duct, ceiling inlet grille and spigot, soffit/wall outlet grille.

**Model** Stock Ref  
**Timer** 441422A

## Dimensions (mm)

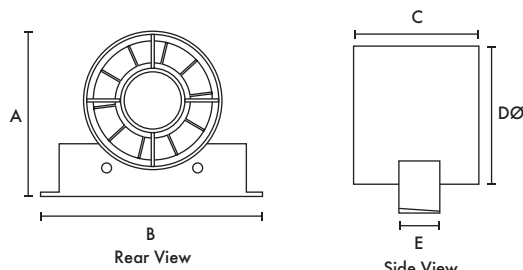

A	B	C	DØ	E
130	155	90	98	27

Internal/External Grille Dimensions 140x140mm

Transformer (W x H x D) 87 x 87 x 33

## Performance Guide

Model	Extract performance			Sound	SFP
	FID	FID	FID	dB(A)	(W/l/s)
	m <sup>3</sup> /h	l/s	Watts	@ 3m	@ OPa
Lo-Carbon Minivent B/T	110	31	6.5	23	0.21



# Lo-Carbon LED Vent-A-Light

- Suitable for shower enclosure and wet areas
- 3W LED Lamp
- Provides simultaneous fan and light operation
- Meets current Building Regulations Approved Documents F & L
- 1 of 2 speeds selectable at installation
- Double insulated fan
- Light assembly Class III
- 5 year Motor Warranty
- Supplied with white and chrome bezels



100mm Lo-Carbon axial in-line shower fan and light kit. Provides simultaneous fan and light operation. Suitable for shower enclosures and wet areas. Available with both a white and chrome bezel on light assembly. The light assembly can be held in place using fixing clips or screws.

## Typical Specification

CE marked in accordance with all the relevant EEC Harmonised Directives.

Fan double insulated and the motor is fitted with Thermal Protection. Light assembly class III.

## Electrical

12 volt DC 3W GU5.3 sealed lamp. Powered by an LED Driver.

LED lamp lumens output 180lm - 200lm

Input, AC. Output - 12 volt DC. 1A.

## Models

### Lo-Carbon Vent-A-Light Fan and LED Light Kit (Basic)

100mm axial in-line shower fan and light kit. Includes fan, 3m flexible ducting, white grille, LED lamp light transformer and light assembly with white and chrome bezels.

**Model** Stock Ref  
Basic 441423A

### Lo-Carbon Vent-A-Light Fan and LED Light Kit (Timer)

100mm axial in-line shower fan and light kit. Fan has electronic overrun timer adjustable from 5 to 30 minutes. The factory setting is 15 minutes. Includes fan, 3m flexible ducting, white grille, LED lamp light transformer and light assembly with white and chrome bezels.

**Model** Stock Ref  
Timer 441424A

## Dimensions (mm)

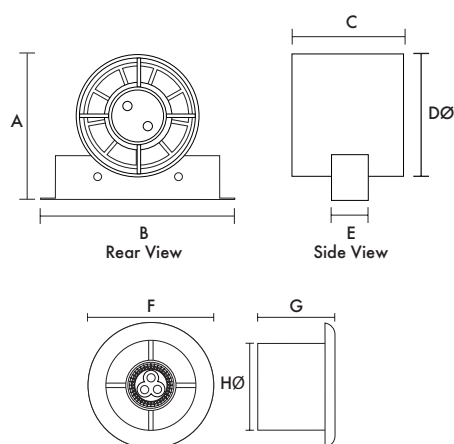

A	B	C	DØ	E	FØ	G	HØ
130	155	90	98	27	140	74	98

Internal/External Grille Dimensions 140x140mm

Fan Transformer (W x H x D) 87 x 87 x 33

## Performance Guide

Model	Extract performance - FID		Fan Watts	Light Watts	Sound dB(A) @ 3m	SFP (W/l/s) @ 0Pa
	m <sup>3</sup> /h	l/s				
Lo-Carbon Vent-A-Light B/T	110	31	6.5	3	23	0.21

Tested at 240V 50Hz

# Lo-Carbon Quadra

- Meets current Building Regulations Approved Document F & L for intermittent or continuous use
- 100mm circular spigot for easy installation and replacement of any existing fan - flush or surface mount
- Filterless technology and maintenance free
- Lo-Carbon motors offering 90% energy savings and long life
- Motor cassette cartridge for simple replacement
- 5 year Motor Warranty
- IPX4 rated
- Suitable for wall, ceiling and panel mounting



## Ventilation for any room

The Lo-Carbon Quadra offers a single fan suitable for surface or flush mounting. Low speed selectable between 6, 9 and 12l/s and high between 15, 30 and 60l/s all with through the wall or two ducted selections to ensure installed performance is met.

## Discrete

With discrete aesthetics and low noise levels due to an accurately balanced impeller, it is also one of the most unobtrusive centrifugal kitchen fans available. The front cover design also provides no area for dirt to build up so it stays looking better for longer.

## Models

### Lo-Carbon Quadra TP (Timer/Pullcord)

Dual speed: continuous running or intermittent to high speed. High speed via pullcord (On/Off) or switch live (with overrun timer).

Model	Stock Ref
TP	439251A

### Lo-Carbon Quadra HTP (Humidistat/Timer/Pullcord)

Dual speed: continuous running or intermittent to high speed. High speed via integral pullcord (On/Off), integral adjustable humidity sensor or switch live (with overrun timer). When humidity sensor is triggered the flow rate increases proportionally with %RH to 50% of the set Boost speed.

Model	Stock Ref
HTP	439181A

### Lo-Carbon Quadra TM (Timer/PIR)

Dual speed: continuous running or intermittent to high speed. High speed via integral PIR sensor or switch live (both with overrun timer).

Model	Stock Ref
TM	439253A

## Accessories

Model	Stock Ref
Flush Mounting Kit	439256
Filter (optional)	439927
Decoration Frame	442551
Wall Kit White	254102
Wall Kit Brown	254100

## Dimensions (mm)

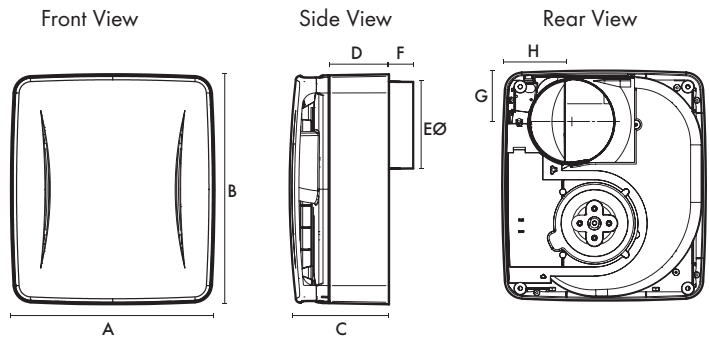

A	B	C	D	EØ	F	G	H
230	260	112	67	98	27	58	79

## Performance Guide\*

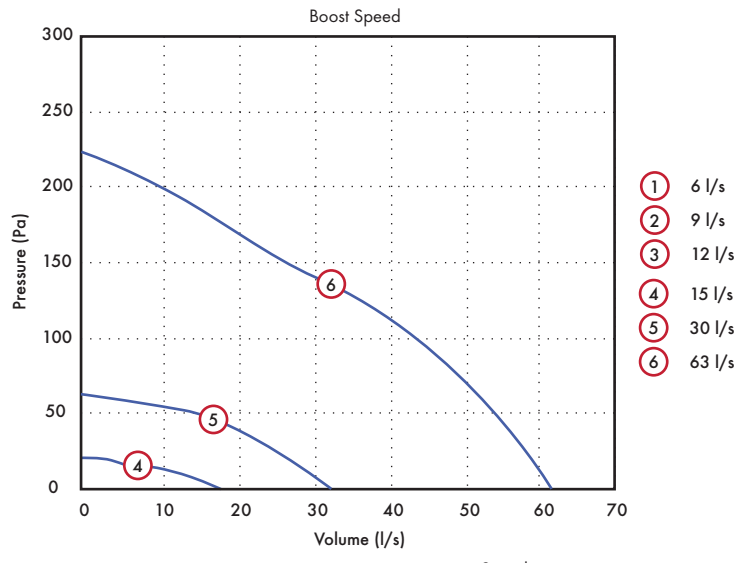
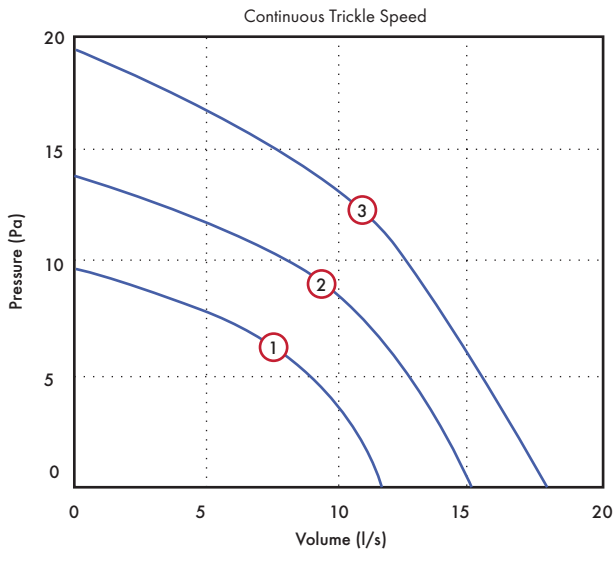

Model	Extract Performance				Power		Sound		SEC Class
	m <sup>3</sup> /h	l/s	m <sup>3</sup> /h	l/s	High Watts	Low Watts	High dB(A) @ 3m	Low dB(A) @ 3m	
Lo-Carbon Quadra TP/ HTP/ TM	227	63	22	6	38	3.8	50	20	D

\*FID Performance. Tested in through the wall installation

# Lo-Carbon Silhouette 125

- Models Basic/Timer/Humidity & Timer
- Low power consumption - Lower running costs
- Quiet running
- Fully opening and closing non transparent shutters - Improved insulation and privacy
- 1 of 2 speeds selectable at installation
- IPX4 rated
- Ball bearing motors for vertical or horizontal application
- Unique humidity sensor track - Improved response
- 5 year motor warranty
- Suitable for wall, ceiling and panel mounting



## Slimline Bathroom Ventilation

With a slim profile of only 18mm, Lo-Carbon Silhouette blends in with the wall surface to provide an unobtrusive installation. Lo-Carbon Silhouette has a FID performance up to 160m<sup>3</sup>/h. It can be ceiling/panel mounted and connected to an appropriate duct run to the outside.

## Models

### Lo-Carbon Silhouette 125B

125mm bathroom/toilet fan with indicator light and back draught shutter.

Model **125B** Stock Ref **446483**

### Lo-Carbon Silhouette 125T (Timer)

125mm bathroom/toilet fan with integral adjustable electronic overrun timer (5-30 minutes), indicator light which operates on manual override only, and back draught shutter.

Model **125T** Stock Ref **446484**

### Lo-Carbon Silhouette 125HT (Humidistat/Timer)

125mm bathroom/toilet fan with integral adjustable auto humidity sensor from 60-90% RH and overrun timer, indicator light which operates on manual override only, and back draught shutter. Datalogger as standard on all Lo-Carbon humidity controlled Silhouette fans.

Model **125HT** Stock Ref **446485**

## Accessories

Model **Wall Kit White** Stock Ref **455226**

## Dimensions (mm)

Panel

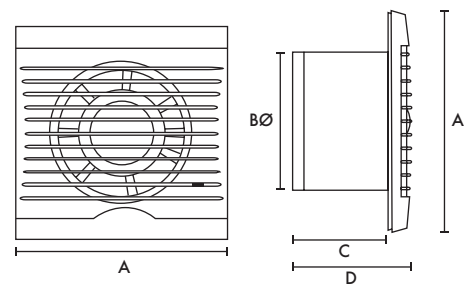

A	BØ	C	D
187	125	131	149

## Performance Guide

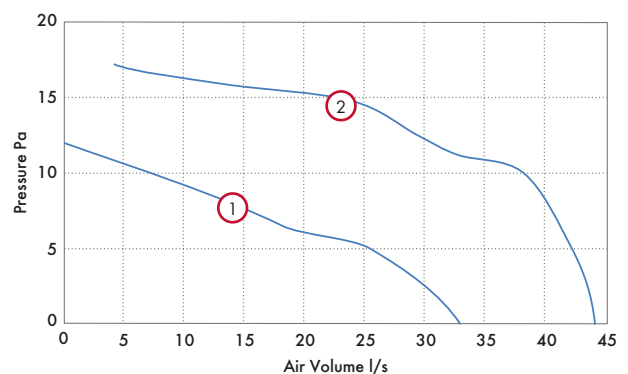

Model	Curve Ref	Extract Performance			Sound dB(A) @ 3m	SFP (W/l/s) @ 0Pa
		m <sup>3</sup> /h	l/s	Watts		
Lo-Carbon Silhouette	Low ①	120	33	4.5	33	0.14
125B/T/HT	High ②	160	44	8	37	0.18



# Lo-Carbon VA150

- Reduces the home's carbon footprint
- Long life Lo-Carbon motor lasts up to 5 times longer than conventional motors
- Up to 60% energy saving
- Meets current Building Regulations Approved Document F & L when installed
- IP44 rated
- Low sound levels
- 5 year Motor Warranty
- Suitable for wall, ceiling, window and panel mounting
- Fitted with a motorised shutter
- 1 of 2 speeds selectable at installation



## Long Life Ventilation

Vent-Axia Lo-Carbon VA150 fans feature Lo-Carbon long life DC energy saving motors that last up to 5 times longer than conventional motors, whilst delivering up to 60% energy savings. The extended life of Lo-Carbon fans is due to the use of a new generation of high quality electronically controlled ball-bearing motors especially developed for this range. The motors are perfectly designed for the wet conditions of utility rooms and kitchens, extracting stale, moisture-laden air quietly and efficiently.

## Shutters

The Vent-Axia Lo-Carbon VA150 range is fitted with a motorised shutter mechanism that uses no extra power in operation or off.

## Installation

The Lo-Carbon VA150 range is suitable for installation in panels, walls or windows using the kits available. Lo-Carbon fans are quick and simple to fit using reversible grommets and easy-wire terminals, and are suitable for wall or ceiling mounting at any angle.

150mm telescopic wall kits are available with a white or brown outside grille. The kit is supplied with a telescopic wall sleeve to fit walls 225-360mm thick. Hole diameter 152mm.

Window fitting kits are available for use with all Lo-Carbon 150mm models through single or double glazed windows up to 40mm thick. Hole diameter 152mm.

## Models

### Lo-Carbon VA150P (Shutter/Pullcord)

Ultra long life DC energy saving motor. Fitted with a motorised shutter. Controlled via pullcord On/Off switch.

Model **VA150P** Stock Ref **459123A**

### Lo-Carbon VA150T (Shutter/Timer)

Ultra long life DC energy saving motor. Fitted with a motorised shutter.

Controlled via integral power supply with electronic adjustable overrun timer (5-30 minutes).

Model **VA150T** Stock Ref **459124A**

### Lo-Carbon VA150HP (Shutter/Humidistat)

Ultra long life DC energy saving motor. Fitted with a motorised shutter. Controlled via integral power supply with pullcord override switch and adjustable humidity sensor (60-95% RH).

Model **VA150HP** Stock Ref **459125A**

## Accessories

Model **Wall Kit White** Stock Ref **140902**  
 Model **Wall Kit Brown** Stock Ref **140903**  
 Model **Window Kit** Stock Ref **140901**

## Dimensions (mm)

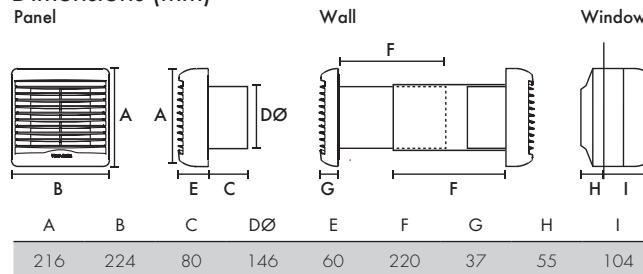

Weight 1.2kg

## Performance Guide

Model	Setting	Extract Performance		Sound	Watts	SFP
		m³/h	l/s	dB(A) @ 3m		(W/l/s) @ 0Pa
Lo-Carbon VA150P/T/HP	Utility	160	46	33	7.5	0.16
	Kitchen	230	64	36	11.5	0.18

# Lo-Carbon Silhouette 150

- Stylish ultra low profile grille
- Downstream airflow guide vanes for improved pressure development
- Ball bearing motors for vertical or horizontal application
- Wall kit design meets Building Regulations Approved Document F requirements
- 5 year Motor Warranty
- 1 of 2 speeds selectable at installation
- IPX4 rated
- Low Specific Fan Power
- Suitable for wall, ceiling and panel mounting



## Slimline Lo-Carbon Kitchen Ventilation

The Lo-Carbon Silhouette 150 range is designed for modern living. With a profile of only 19mm on the kitchen models, Lo-Carbon Silhouette blends in with the wall surface to provide an unobtrusive installation.

Mounted in the centre of the fan, beneath the ultra slim profile grille, are the electronics, incorporating a humidistat (HT model) for detecting a change in internal humidity or an overrun timer option that is adjustable between 5 and 30 minutes. FID performance of 65l/s, double insulated. Power consumption only 9 Watts.

## Models

### Lo-Carbon Silhouette 150B

150mm kitchen fan with indicator light and back draught shutter.

Model	Stock Ref
150B	441628A

### Lo-Carbon Silhouette 150T (Timer)

150mm kitchen fan with integral adjustable electronic overrun timer (5-30 minutes), indicator light which operates on manual override only and spring back draught shutter.

Model	Stock Ref
150T	441629A

### Lo-Carbon Silhouette 150HT (Humidistat/Timer)

150mm with integral adjustable auto humidity sensor from 60-90% RH and overrun timer, indicator light which operates on manual override only and back draught shutter. Datalogger as standard on all Lo-Carbon humidity controlled Silhouette fans.

Model	Stock Ref
150HT	441630A

## Accessories

Model	Stock Ref
Wall Kit White	140902
Wall Kit Brown	140903

## Dimensions (mm)

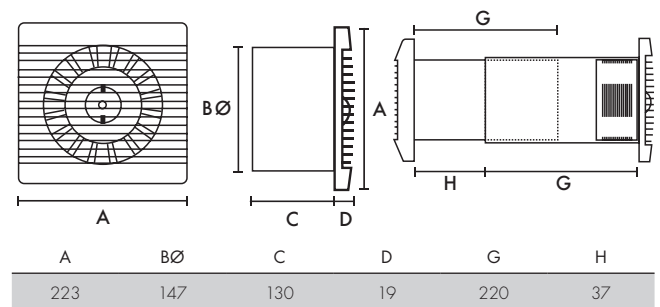

Weight 1.75kg

## Performance Guide

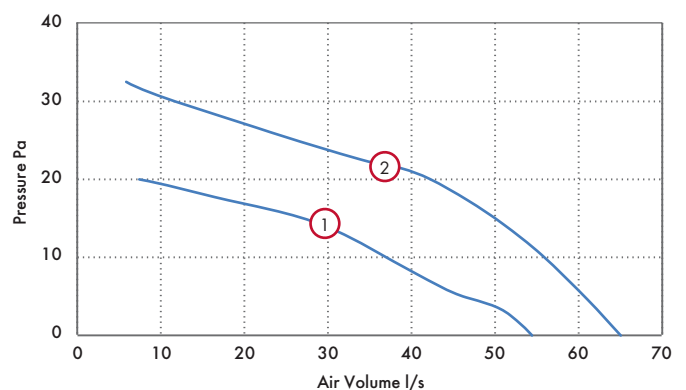

Model	Setting	Curve Ref	Extract Performance			Sound	SFP
			m <sup>3</sup> /h	l/s	Watts	dB(A) @ 3m	(W/l/s) @ 0Pa
150B/T/HT	Utility Setting	1	200	55	6	35	0.11
	Kitchen Setting	2	234	65	9	43	0.14

Fixing hole diameter 152mmØ (when wall kit used)

**Vent-Axia**

VENTILATION EXCELLENCE

Smart, Stylish, Silent Bathroom Fans



PUREAIR SENSE

Bathroom Fan with Odour Sense Technology



SVARA

Stylish and Versatile Bathroom Fan



SILENT FAN

Silently Improving Indoor Air Quality

Please visit your local wholesaler for more information



# dMEV, MEV & PIV Systems



## What is dMEV & MEV?

The latest Building Regulations Approved Document F gives examples of three main methods of ventilation. Continuous mechanical extract ventilation, can be achieved using a single centralised extract unit such as the Sentinel Multivent ducted from 'wet' rooms (kitchen, bathroom, en-suite and WC) or by decentralised individual fans (dMEV) in the 'wet' rooms. The fans run continuously at near silent levels providing a simple and effective form of ventilation.

## NEW Lo-Carbon Response 7

The intelligent Lo-Carbon Response 7 is a NEW filterless unitary fan designed to meet the specific needs of social housing. Boasting powerful, quiet, efficient ventilation, the Response 7 provides good indoor air quality and comfort for residents while being quick and easy to install, low maintenance and reliable.

## Smart Sense™ Technology

Featuring Smart Sense™ intelligent technology Response 7 is quick and easy to install due to its simple alphanumeric LED display which is clear, easy to read and has a three-button menu for commissioning and data gathering.

**Vent-Axia**®





Lo-Carbon NBR dMEV C

B3-B4



Lo-Carbon Centra®/SELV  
dMEV Unit

B5-B6



Lo-Carbon Response 7/SELV 100  
dMEV Unit

B7-B8



Lo-Carbon Response 7 125  
dMEV Unit

B9-B10



Lo-Carbon Sentinel® Multivent/Plus  
MEV Unit

B11-B14



Lo-Carbon MVDC-MS/MSH Multivent  
MEV Unit

B15-B16



Lo-Carbon MVDC-MSH Uniflex Multivent  
MEV Unit

B17-B18



Lo-Carbon NBR dMEV

B19-B20



Lo-Carbon PoziDry Pro™  
Positive Input Ventilation

B21-B22



Lo-Carbon PoziDry Compact  
Positive Input Ventilation

B23-B24



# Lo-Carbon NBR dMEV C

- Continuously running 100mm and 125mm dMEV with sleek circular design
- Designed to comply with the latest Building Regulations Parts L1A and F 2021
- SAP PCDB listed with SFP's down to 0.08 W/l/s
- Near silent operation independently tested
- IPX5 rated, wall and ceiling mounted Zones 1, 2 and 3
- Low ceiling void - 56mm (100mm spigot) and 66mm (125mm spigot)
- Easy to commission, fully adjustable variable control platform
- Intelligent humidistat model option with proportional increase and timer
- Comfort control option
- 7- year warranty

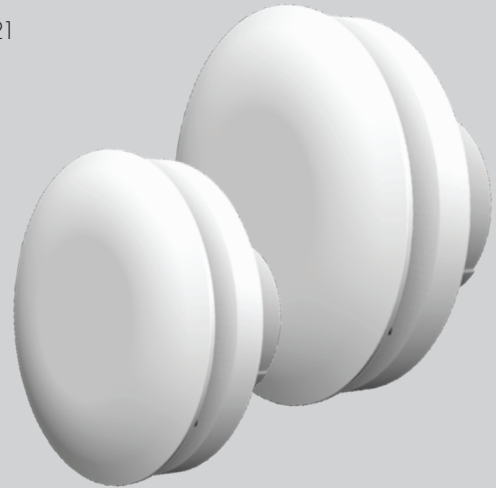

## Lo-Carbon NBR dMEV C

Increased whole ventilation rates, should not mean increased noise levels. The Vent-Axia Lo-Carbon NBR dMEV C fan, available in 100mm and 125mm, provides adequate ventilation whilst minimising noise.

The fan is designed in line with the Approved Document F 2021 Building Regulations, meeting the increased whole house ventilation rates.

Table 1.3 - Minimum whole dwelling ventilation rates determined by the numbers of bedrooms.

No. of bedrooms	2013 Edition	2021 Edition	Increase
1	13l/s	19l/s	46%
2	17l/s	25l/s	47%
3	21l/s	31l/s	47%
4	25l/s	37l/s	48%
5	43l/s	43l/s	48%

The minimum whole dwelling ventilation rate for the supply air should meet the higher of the two following result:

- A minimum rate of 0.3l/s per m<sup>2</sup> of internal floors area
- A minimum rate determined by the number of bedroom, as per Table 1.3

Nuisance tripping has also been minimised within the fan logic. The integral humidity sensor versions have functionality that allows for proportional speed increase up to 85% relative humidity (RH) before enabling Boost.

The Lo-Carbon NBR dMEV C is complete with IPX5 rating, allowing flexible installation within Zone 1, 2 and 3.

A back pressure detection system option is available, to Boost if the system pressure increase momentarily due to external wind conditions. A silent mixed flow impeller means the Lo-Carbon NBR dMEV C can meet the requirements of many domestic installations without the need to use a traditional centrifugal fan.

A brand new control platform also provides fully adjustable airflow, meaning wholehouse rates can be achieved easily using fewer fans.

## Comfort Control Option

Designed to offer a more relaxing environment to the homeowner, the Lo-Carbon NBR dMEV C features a delayed start. This patented comfort control option allows the homeowner to enjoy a quiet, peaceful bathroom for up to 20 minutes before the Boost activates. Furthermore, if the light switch turns On and Off within three minutes, the Boost will not activate. No more disturbing the family if the bathroom light is turned on during the night.

## Near Silent Operation

The fan has been designed to be as discreet as possible for homeowners, with independently tested sound levels as low as 7.4dB(A).

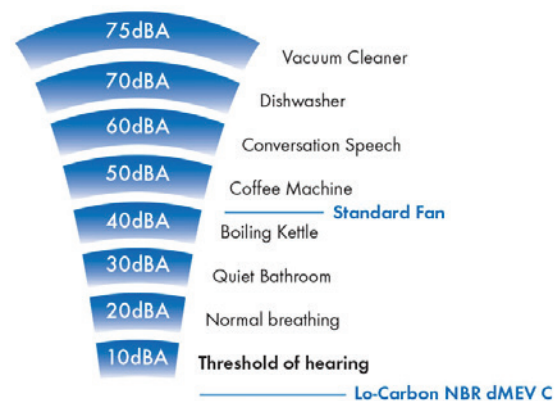

## Model

### Lo-Carbon NBR dMEV C

For kitchen, utility and bathroom/toilet applications, the continuous running dMEV C fan is available as standard or as a humidistat model which incorporates an ambient response humidistat. The fan will increase the extract rate if the humidity rises above the point set at installation. Both fans will have optional Comfort Control, which includes a timer function.

Variable speed setting

Model	Stock Ref
Lo-Carbon NBR dMEV C 100	498095
Lo-Carbon NBR dMEV C 100 HT	498096

Variable speed setting

Model	Stock Ref
Lo-Carbon NBR dMEV C 125	498097
Lo-Carbon NBR dMEV C 125 HT	498098

## Accessories

Model	
Stock Ref	
Wall Kit White 100mm	254102
Wall Kit Brown 100mm	254100
Wall Kit White 125mm	455226
Wall Kit Brown 125mm	497434
Wall Kit Terracotta 125mm	497432

## Consultant Specification

The de-centralised mechanical extract ventilation unit shall be the Lo-Carbon NBR dMEV C as manufactured by Vent-Axia, exact unit sizing and specification shall be in accordance with the particular specification.

The range should consist of IPX5 rated 100mm and 125mm sizes to meet the Building Regulations compliant design, extracting air from wet rooms (including kitchen and utility) via rigid, flexible ducting or through-wall applications with the fewest fans possible, supplied with a 7 - year warranty.

The 100mm Lo-Carbon NBR dMEV C should have variable speed settings of 5-26 l/s achieving a minimum noise level of 7.4dB(A) at 3 metres. The 125mm Lo-Carbon NBR dMEV C should have variable speed settings of 5-35 l/s achieving a minimum noise level of 8.5dB(A) at 3 metres. All sound pressure levels are quoted at hemispherical measurements. All units shall be and independently third-party tested at the Sound Research Laboratory (SRL), tested to BS EN 13141-6.

The unit shall comprise a single high efficiency EC/DC motor to deliver specific fan powers as low as 0.08 W/l/s, as measured in accordance with the SAP PCDB test method and listed on the PCDB database.

The controls for the Lo-Carbon NBR dMEV C unit shall provide fully adjustable, continuous whole house ventilation rates. The Boost speed shall be activated via an integral humidistat or via LS Input.

The fan shall be compatible with low ceiling voids and have a spigot length of 56mm (100mm) and 66mm (125mm).

The fan shall have the nuisance tripping prevention option called Comfort Control, which stops the fan from engaging Boost when the LS input is engaged for less than three minutes.

The unit shall be able to be commissioned as a continuous running fan according to the Building Regulations compliant design.

## Dimensions (mm)

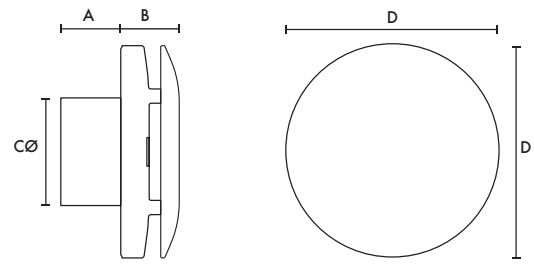

Model	A	B	CØ	D
100	56	54	99	195
125	66	57	120	228

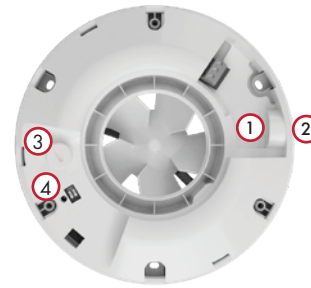

- 1 Rear cable entry
- 2 Side cable entry (cut plastic side wall to access)
- 3 100% variable speed adjustment
- 4 Installation mode (SW1) Back pressure detection system (SW2)

## Performance Guide

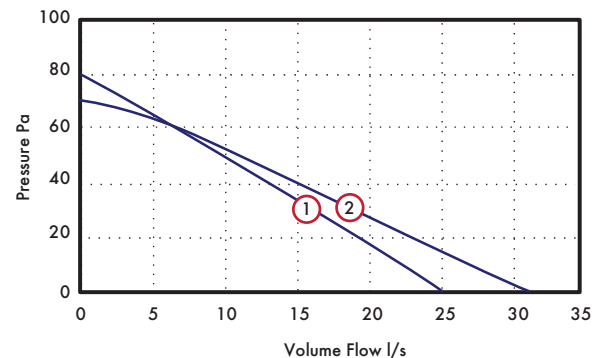

- 1 100mm dMEV C Max Speed
- 2 125mm dMEV C Max Speed

## Sound

Model	Speed	dB(A)
100	Min	7.4
	Max	34.3
125	Min	8.5
	Max	37.9

## SAP PCDB Performance 2021

Unit configuration	Location	100 Model	125 Model
In room (Rigid duct)	Kitchen (13l/s)	0.14	0.14
	Kitchen/wet room (8l/s)	0.11	0.12
Through wall	Kitchen (13l/s)	0.08	0.09
	Kitchen/wet room (8l/s)	0.08	0.10

# Lo-Carbon Centra/SELV

- Building Regulations Approved Documents F and L compliant
- Continuous mechanical extract
- Discreet, tasteful styling
- IPX4 rated - IPX7 rated (SELV)
- dMEV Pressure detection device
- 5 year motor warranty
- Suitable for wall, ceiling, panel and window mounting
- SELV models supplied with remote transformer and suitable for 'Zone 1'



## What is de-centralised MEV (dMEV)?

Building Regulations Approved Document F gives examples of three main methods of ventilation. Continuous mechanical extract ventilation, can be achieved using a single centralised extract unit such as the Sentinel Multivent ducted to 'wet' rooms (kitchen, bathroom, en-suite and WC) or by decentralised individual fans, such as the Lo-Carbon Centra in the 'wet' rooms. The fans run continuously at near silent levels providing a simple and effective form of ventilation.

SELV (Safety Extra Low Voltage) is designed for areas where a fan can be installed within Zone 1 in a room where there is a fixed bath or shower. Ingress Protected (IP) to IPX7 Lo-Carbon Centra SELV can be fitted safely within the spray area. The separate transformer can be mounted away from the spray zone and out of reach from the bath or shower.

The Lo-Carbon Centra meets the latest requirements of the Building Regulations Approved Document F for wholehouse system ventilation and all models come with a 5 year motor warranty.

Selection of the two trickle flow rates (6l/s or 9l/s) is via a simple 'jumper' on the control board. Different methods are available for operating the 15 l/s boost speed from a simple switched live to integral humidistat. See individual models for further details.

The attractive and discreet styling of the Vent-Axia Lo-Carbon Centra will complement the décor of any new home while virtually silent operation ensures optimum ventilation is achieved without intrusive noise.

---

## Specific Fan Power

Lo-Carbon Centra has a specific fan power of only 0.18 W/l/s in through-the-wall kitchen applications.

---

## Models

### Lo-Carbon Centra dMEV

Auto speed selection at installation and suitable for bathrooms or kitchens. The integral air pressure sensor checks the airflow when first installed and also helps the fan to compensate for external wind pressure.

#### Stock Ref

**441782B**

### Lo-Carbon Centra T/SELV T (Timer)

Ideal for bathroom and toilet applications, this unit runs continuously on trickle setting and may be boosted by the switched live input which activates the timer (fixed 15 min on T models, adjustable 5-30 minutes on SELV models).

#### Model

#### Stock Ref

T

**473825**

SELV T

**443175A**

### Lo-Carbon Centra TP/SELV TP (Timer/Pullcord)

For bathroom/toilet applications, the continuous running TP model is boosted by the pullcord which activates the timer (fixed 15 min on TP models, adjustable 5-30 minutes on SELV models).

#### Model

#### Stock Ref

TP

**473826**

SELV TP

**447128A**

### Lo-Carbon Centra HT/SELV HT (Humidistat/Timer)

For bathroom/toilet applications, the continuous running HT model is automatically boosted by the built-in humidistat or by a switched live input which activates the timer (fixed 15 min on HP models, adjustable 5-30 minutes on SELV models).

#### Model

#### Stock Ref

HT

**473827**

SELV HT

**443176A**

### Lo-Carbon Centra HTP/SELV HTP (Humidistat/Timer/Pullcord)

For bathroom/toilet applications, the continuous running HTP model is automatically boosted by the built-in humidistat or by the pullcord which activates the timer (fixed 15 min on HTP models, adjustable 5-30 minutes on SELV models).

Model	Stock Ref
HTP	473828
SELV HTP	443177A

### Dimensions (mm)

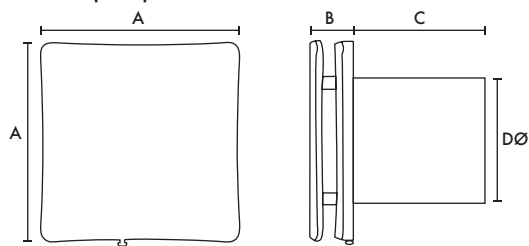

Model	A	B	C	DØ
Lo-Carbon Centra dMEV/All SELV	160	35	115	99
Lo-Carbon Centra T/TP/HT/HTP	160	35	115	99

Transformer 87 x 87 x 33mm (W x H x D) (SELV models only)

### Accessories

Model	Stock Ref
150mm Conversion Kit	443334
Wall Kit White	254102
Wall Kit Brown	254100
Window Kit	442947
Ceiling Kit	443800

### Performance Guide

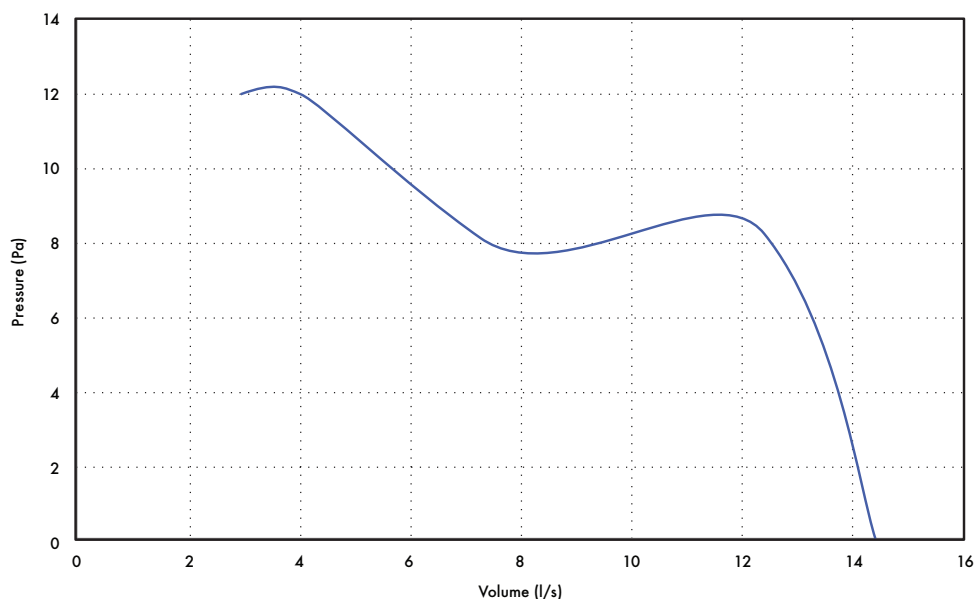

Model	Extract Performance (l/s)			Power Consumption (Watts)			Sound dB(A)@ 3m		
	Trickle	Trickle	Boost	Trickle	Trickle	Boost	Trickle	Trickle	Boost
	Low	High		Low	High		Low	High	
Lo-Carbon Centra dMEV/All SELV	6	9	15	1.4	1.6	2.4	10.8	15.5	25.2
Lo-Carbon Centra T/TP/HT/HTP	6	9	15	3.2	3.5	4.2	10.8	15.5	25.2

# NEW Lo-Carbon Response 7/SELV 100

- Designed especially for Social Housing
- Ultra low profile for discreet installation
- Continuous running fan
- 7 year warranty
- High performance on trickle to avoid going to boost too often
- IP45 Rated - IPX7 on SELV models
- Small footprint with optional decoration frame
- Unique settings lock to prevent tampering
- Intelligent Smart Sense™ technology tells you days run, boost hours run, energy used
- Airflow sensor models UKAS calibrated
- Registered the PCDB for use with SAP 10.2



## Designed for Social Housing

The intelligent Lo-Carbon Response 7 is an innovative filterless unitary fan designed to meet the specific needs of social housing. Boasting powerful, quiet and efficient ventilation, the Response 7 provides good indoor air quality for the home and increases comfort for residents, while being quick and easy to install, low maintenance and reliable.

## Smart Sense™ Technology

Featuring Smart Sense™ intelligent technology, the Response 7 is quick and easy to install thanks to its simple alphanumeric LED display - it has a three-button menu for simple commissioning and easy data gathering. Smart Sense™ technology even tells the LED display which orientation to use depending on whether the fan is wall or ceiling mounted. All of which saves time on site and reduces installation complications. The Response 7 benefits from a unique settings lock to prevent tampering with the unit; giving the landlords peace of mind.

The display also shows real-time data so landlords can reassure residents of the low-running costs - the data includes, days run, hours on trickle or boost, and even more specifically, hours run on boost triggered by the humidity sensor. The Response 7 can also tell you how much energy the fan has used in total or over a 24 hour period.

## Side View of Airflow Display

Be confident that the Response 7 is delivering the right performance with our innovative digital display showing the airflow and system pressure of the installed product.



## Comfort Control Option

Designed to offer a more relaxing environment to the homeowner, the Lo-Carbon Response 7 features a delayed start option. This patented comfort control option is selectable at installation and allows the resident to enjoy a quiet, peaceful bathroom for up to 20 minutes before the "Boost" activates, drastically improving resident acceptability. Furthermore, if the light switch turns "On" and "Off" within 3 minutes, the

"Boost" will not activate. No more disturbing the family if the bathroom light is turned on during the night.

## Model

### Lo-Carbon Response 7/SELV

A discreet and intelligent HTP bathroom fan specifically designed for social housing. Day logger and power run meter as standard. 7 year warranty. Built-in lock function. Adjustable dynamic ambient response humidity sensor. Timer adjustable between 1 and 30 minutes. Inbuilt boost activated by pullcord, humidity sensor, switched live or remote button. Tile front for discreet installation.

Variable Speed Settings (5-30 l/s trickle, 6-35 l/s boost).

Model	Stock Ref
Response 7 100	494143
Response 7 100 SELV	494150

### Lo-Carbon Response 7 Pro/SELV

A discreet and intelligent HTP bathroom fan specifically designed for social housing. Day logger and power run meter as standard. 7 year warranty. Built-in lock function. Adjustable dynamic ambient response humidity sensor. Timer adjustable between 1 and 30 minutes. Inbuilt boost activated by pullcord, humidity sensor, switched live or remote button. Tile front for discreet installation. Constant volume for accurate installed performance.

Variable Speed Settings (5-30 l/s trickle, 6-35 l/s boost).

Model	Stock Ref
Response 7 100 Pro	494144
Response 7 100 Pro SELV	494149

## Accessories

Model	Stock Ref
100mm Internal Fit Wall Kit White	472318
100mm Internal Fit Wall Kit Brown	472319
100mm to 150mm Conversion Kit	408680
100mm Ceiling Kit	407928
100mm Window Kit	407927
100mm Decoration Frame	474041



Dimensions (mm)

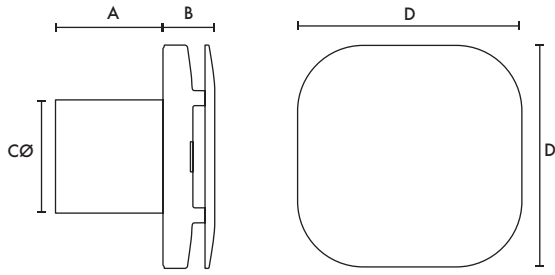

A	B*	CØ	D
81	43	99	190

Decoration Frame Dimensions (mm)

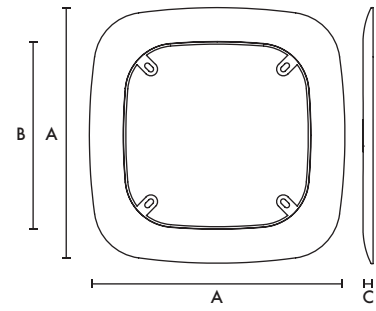

A	B	C
259	191	10

Performance Guide

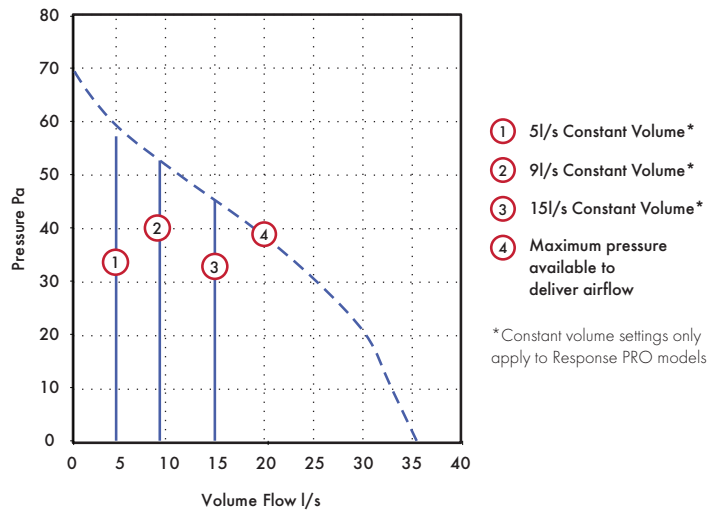

Extract Performance - FID

Air Performance (l/s)	m <sup>3</sup> /h	Watts	Sound dB(A) @ 3m
5	18	1	13.2
9	32	1.2	17.3
15	54	1.6	23.9
35	126	8.3	41.2

SAP PCDB Performance (SAP 10.2)

Unit Configuration	Location	Fan speed setting	SFP (W/l/s)
In room	Kitchen	11	0.19
	Wet room	7	0.18
In duct	-	-	-
	-	-	-
Through wall	Kitchen	13	0.11
	Wet room	8	0.14

# Lo-Carbon Response 7 125

- Designed especially for Social Housing
- Ultra low profile for discreet installation
- Continuous running fan
- 7 year warranty
- High performance on trickle to avoid going to boost too often
- IP45 Rated
- Small footprint with optional decoration frame
- Unique settings lock to prevent tampering
- Intelligent Smart Sense™ technology tells you days run, boost hours run, energy used
- Airflow sensor models UKAS calibrated



## Designed for Social Housing

The intelligent Lo-Carbon Response 7 is an innovative filterless unitary fan designed to meet the specific needs of social housing. Boasting powerful, quiet and efficient ventilation, the Response 7 provides good indoor air quality for the home and increases comfort for residents, while being quick and easy to install, low maintenance and reliable.

## Smart Sense™ Technology

Featuring Smart Sense™ intelligent technology, the Response 7 is quick and easy to install thanks to its simple alphanumeric LED display - it has a three-button menu for simple commissioning and easy data gathering. Smart Sense™ technology even tells the LED display which orientation to use depending on whether the fan is wall or ceiling mounted. All of which saves time on site and reduces installation complications. The Response 7 benefits from a unique settings lock to prevent tampering with the unit; giving the landlords peace of mind.

The display also shows real-time data so landlords can reassure residents of the low-running costs - the data includes, days run, hours on trickle or boost, and even more specifically, hours run on boost triggered by the humidity sensor. The Response 7 can also tell you how much energy the fan has used in total or over a 24 hour period.

## Side View of Airflow Display

Be confident that the Response 7 is delivering the right performance with our innovative digital display showing the airflow and system pressure of the installed product.



## Comfort Control Option

Designed to offer a more relaxing environment to the homeowner, the Lo-Carbon Response 7 features a delayed start option. This patented comfort control option is selectable at installation and allows the resident to enjoy a quiet, peaceful bathroom for up to 20 minutes before the "Boost" activates, drastically improving resident acceptability.

Furthermore, if the light switch turns "On" and "Off" within 3 minutes, the "Boost" will not activate. No more disturbing the family if the bathroom light is turned on during the night.

## Model

### Lo-Carbon Response 7

A discreet and intelligent HTP bathroom fan specifically designed for social housing. Day logger and power run meter as standard. 7 year warranty. Built-in lock function. Adjustable dynamic ambient response humidity sensor. Timer adjustable between 1 and 30 minutes. Inbuilt boost activated by pullcord, humidity sensor, switched live or remote button. Tile front for discreet installation.

Variable Speed Settings (9-30 l/s trickle, 10-35 l/s boost).

Model  
Response 7 125

Stock Ref  
496738

### Lo-Carbon Response 7 Pro

A discreet and intelligent HTP bathroom fan specifically designed for social housing. Day logger and power run meter as standard. 7 year warranty. Built-in lock function. Adjustable dynamic ambient response humidity sensor. Timer adjustable between 1 and 30 minutes. Inbuilt boost activated by pullcord, humidity sensor, switched live or remote button. Tile front for discreet installation. Constant volume for accurate installed performance.

Variable Speed Settings (9-30 l/s trickle, 10-35 l/s boost).

Model  
Response 7 125 Pro

Stock Ref  
496689

## Accessories

Model  
125mm Wall Kit White

Stock Ref  
455226

## Dimensions (mm)

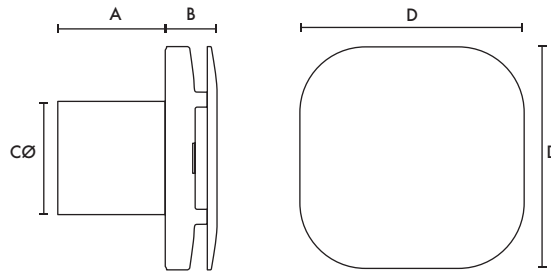

A	B*	CØ	D
100	46	115	213

## Performance Guide

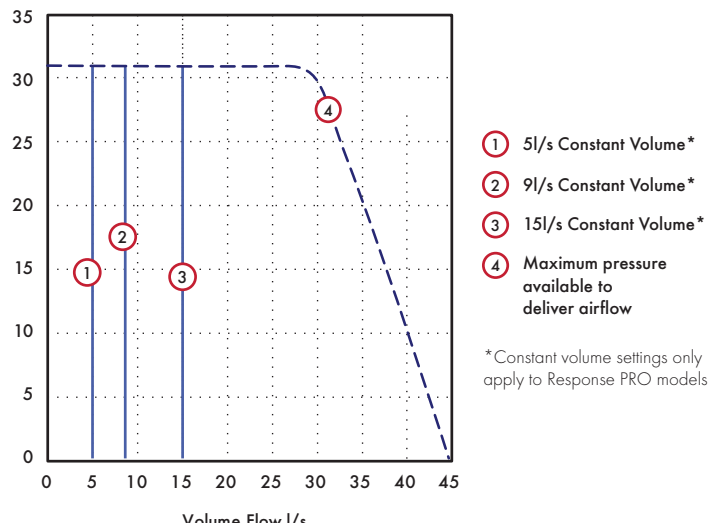

Extract Performance - FID

Air Performance (l/s)	m <sup>3</sup> /h	Watts	Sound dB(A) @ 3m
5	18	1	12
41	148	10.7	36

## SAP PCDB Performance

Unit Configuration	Location	SFP (W/l/s)
In room (rigid duct)	Kitchen	0.16
	Wet room	0.20
In room (flex-duct)	Kitchen	0.15
	Wet room	0.20
Through wall	Kitchen	0.12
	Wet room	0.16

# Lo-Carbon Sentinel Multivent/Plus

- Reduces your carbon footprint
- Recognised in SAP PCDB
- Specific fan power as low as 0.16 W/l/s
- Suitable for use with external sensors and controllers
- Wireless control option for "X" models
- Complies with Building Regulations ADF and ADL
- Manufactured in the UK
- Integral adjustable overrun timer and delay on timer



Sentinel Multivent continuous mechanical extract ventilation, MEV is designed for the simultaneous ventilation of separate areas in the home or as a multipoint extraction system for a wide range of commercial applications. The units can be wall, ceiling or loft mounted. Where the ambient air has a high humidity content condensate drains are provided.

## In support of Sentinel Multivent, Vent-Axia offers:

- Practical advice on product selection and installation
- Guidance on solutions to meet legislation requirements
- Project management and site deliveries
- After sales support and maintenance information

## The need to improve efficiency

Sentinel Multivent has been designed to meet the exacting demands of developers, installers and users offering advanced control options and easier installation and commissioning.

- Demand Control - enables precise ventilation rate, is set in 1% increments based on property size
- Comfort mode allows homeowners to control when the unit runs and for how long to avoid disturbance
- Integral digital display allows the installer to select appropriate low, normal, boost and purge speeds to meet demand
- Manual and automatic control options
- Integral adjustable overrun timer and delay on timer
- Switched live and SELV connections
- Optional Wireless Control on "X" units
- Energy efficient EC/DC motors - 1/3 less energy lost to heat than a conventional AC motor
- Low Specific Fan Power (SFP) making it one of the most efficient products on the market

## Legislation

- Meets Building Regulations Approved Document F (System 3)
- Recognised in SAP PCDB up to kitchen + 6 wet rooms
- Meets carbon footprint reduction targets
- The need for better health: Removal of pollutants such as moisture, carbon dioxide and external fumes are all important factors

in maintaining indoor air quality, helping to create a healthier living environment

- The integral humidity sensor (Sentinel Multivent H) increases fan speed in proportion to relative humidity levels, saving energy and reducing noise
- The sensor also reacts to small but rapid increases in humidity, even if the normal trigger threshold is not reached. This unique feature ensures adequate ventilation, even for the smallest wet room
- Night time relative humidity increment setback feature suppresses nuisance tripping as humidity gradually increases with falling temperature

## SAP PCDB

In order to make the right choice, developers and contractors should refer to Building Regulations ADL1a, SAP 2012 and SAP PCDB.

SAP PCDB was launched in June 2006 to reward innovative ventilation manufacturers by testing and listing energy efficient products that assist in helping developers meet their Target Emission Rates (TER).

SAP is the underpinning methodology behind the Energy Performance Certificates and is used to demonstrate compliance with Building Regulations for Dwellings - Approved Document L (England and Wales), Section 6 (Scotland) and Approved Document F (Northern Ireland). SAP PCDB specifically relates to wholehouse ventilation systems and lists a number of Vent-Axia Mechanical Ventilation solutions which offer an improved SAP rating over and above the default for these product types.

## SEC Class

Model	SEC Class (inc. LDC)
Sentinel Multivent/Plus	B

## SAP PCDB Test Results (Sentinel Multivent and Multivent Plus)

Exhaust Terminal Configuration	Total Flow Rate (l/s)	SFP (W/l/s)
K+1	21	0.17
K+2	29	0.16
K+3	37	0.17
K+4	45	0.18
K+5	53	0.21
K+6	61	0.24

To assist developers and contractors Vent-Axia can provide detailed scheme designs together with installation guidance and training.

## Your Carbon Footprint

Carbon footprint is a measure of the amount of carbon dioxide (CO<sub>2</sub>) emitted through the burning of fossil fuels. From a residential and commercial building perspective, it is the amount of carbon generated when you consume a kiloWatt (kW) of electricity. Reducing a building's carbon footprint will ultimately reduce electricity bills and save money for every individual household or business. It will also help meet the UK target for the reduction of emissions, as well as allowing you to help the environment.

## Model

	Stock Ref
Sentinel Multivent H	445655B
Sentinel Multivent HX	495360
Sentinel Multivent HX CO <sub>2</sub>	495361
Sentinel Multivent Plus H	407849A
Sentinel Multivent Plus HX	495362
Sentinel Multivent Plus HX CO <sub>2</sub>	495363

## Accessories



	Stock Ref
Anti Vibration Mounts (Pack of 4)	68MP033G

## Dimensions (mm)

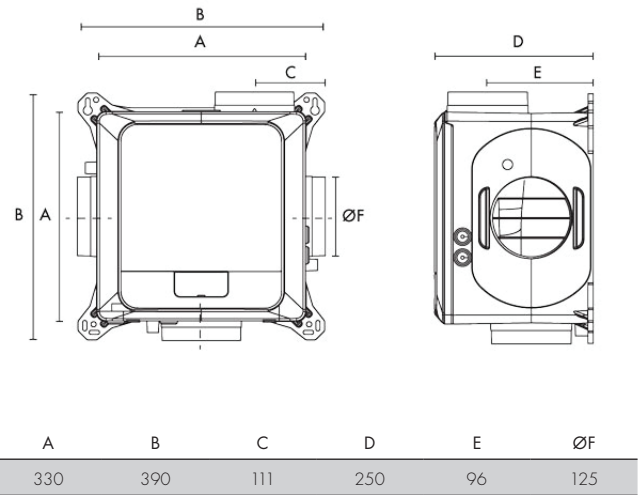



## Performance Guide

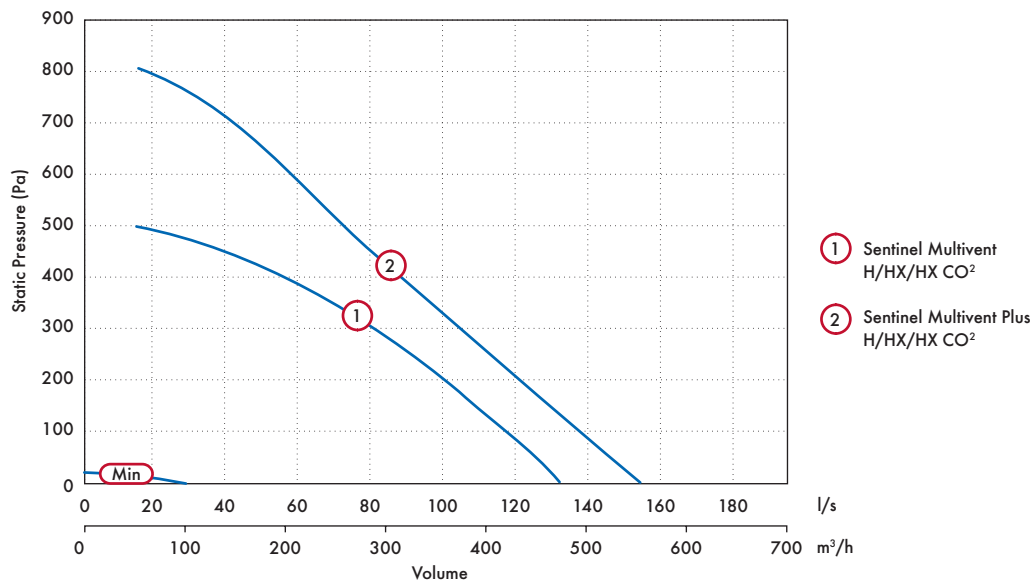

Stock Ref	Model	Curve Ref	FID (l/s)	Power Watts	IP Rating
445655 / 495360 / 495361	Multivent	1 (max)	128	52	IPX2
407849 / 495362 / 495363	Multivent Plus	2 (max)	159	85	IPX2

## Sound Data

Model	Speed	Test Mode	Octave Band (Hz) Sound Power Levels, dB								LwA	SpL @ 3m
			63	125	250	500	1k	2k	4k	8k		
Sentinel Multivent	20%	Extract	32.5	50.7	41.9	37.5	28.4	19.4	17.8	22.3	38.0	20.5
		Breakout	28.7	37.6	32.5	29.6	20.9	14.8	17.9	22.7	30.5	10.0
	40%	Extract	33.4	51.3	52.7	48.2	41.8	38.0	24.0	22.8	49.2	31.7
		Breakout	34.1	52.7	42.6	38.9	30.3	24.8	18.5	22.6	42.0	21.5
	60%	Extract	38.2	53.3	70.5	58.9	49.5	46.0	35.8	27.2	61.5	44.0
		Breakout	44.8	48.4	54.4	45.4	37.6	32.6	23.6	22.8	47.4	26.9
	80%	Extract	41.7	55.5	70.3	60.6	55.3	52.7	43.5	35.9	64.2	46.7
		Breakout	41.8	51.6	61.9	50.9	43.5	39.5	30.3	23.9	55.1	34.6
	100%	Extract	46.3	58.1	75.1	66.7	60.1	58.0	49.1	43.3	70.2	52.7
		Breakout	46.0	54.0	63.2	55.3	47.8	44.6	35.7	27.0	58.3	37.8

Tested according to BS EN 13141-6:2010. Breakout quoted spherical. Extract quoted hemispherical.

Model	Speed	Test Mode	Octave Band (Hz) Sound Power Levels, dB								LwA	SpL @ 3m
			63	125	250	500	1k	2k	4k	8k		
Sentinel Multivent Plus	20%	Extract	30.3	49.6	43.5	40.4	33.2	25.2	18.2	22.4	40.3	22.8
		Breakout	30.5	39.8	35.3	31.3	22.3	16.5	17.9	22.8	32.5	12.0
	40%	Extract	43.5	54.7	60.8	54.5	46.2	42.5	31.0	24.5	54.5	37.0
		Breakout	47.0	49.3	54.0	42.1	33.9	29.1	20.6	22.6	45.7	25.2
	60%	Extract	40.8	55.2	67.0	61.0	54.0	50.9	41.3	33.3	62.1	44.6
		Breakout	40.1	51.2	58.7	48.2	41.3	37.4	28.4	23.5	52.0	31.5
	80%	Extract	45.5	57.6	79.1	66.3	59.7	57.5	48.5	42.7	73.2	55.7
		Breakout	45.6	54.6	64.5	54.7	46.5	44.2	35.2	26.5	59.1	38.6
	100%	Extract	52.7	61.8	71.6	81.8	66.1	62.7	54.0	49.2	77.8	60.3
		Breakout	56.0	56.6	61.2	63.1	51.3	49.0	40.4	31.4	60.9	40.4

Tested according to BS EN 13141-6:2010. Breakout quoted spherical. Extract quoted hemispherical.

## Sentinel-X Controllers



### Internal Temperature and Humidity - Wireless - Battery

Room mounted humidity and temperature sensor for wired or wireless communication with a compatible system. Using an in-built RF 868 MHz (Wireless radio frequency), or RS485 (Wired connection) communication method whilst being powered by batteries.

- Dimensions (HxWxD) (mm) 60 x 60 x 22
- 2 x AAA Batteries included
- Temperature range 0~60°C
- Relative humidity range 0-90% RH
- Wireless range 20m closed/100m open
- RF 868MHz Wireless or RS485 Wired communication
- Status LED indicator for pairing, health check and fault conditions
- Mounted using provided back plate

Stock Ref  
**496431**



### 4 Speed Switch with Temperature and Humidity - Wireless - Battery & 240V

Room mounted Speed Switch for wireless communication with a compatible system. Using an in-built RF 868 MHz (Wireless radio frequency) communication. Battery and 240V model options.

- Dimensions (HxWxD) (mm) 90 x 90 x 17
- 2 x AAA Batteries (Battery Model) / Power supply 240V (240V Model)
- Temperature range 0~60°C
- Relative humidity range 0-90% RH
- Wireless range 20m closed/100m open
- RF 868MHz Wireless
- Mounted using provided back plate or compatible with a standard single gang or surface mounted pattress box
- Status LED indicator for pairing, health check and fault conditions

Model	Stock Ref
White (Battery)	<b>496437</b>
Black (Battery)	<b>497689</b>
White (240V)	<b>496620</b>
Black (240V)	<b>497693</b>



### Internal Temperature and Humidity - Wireless - 240V

Room mounted humidity and temperature sensor for wired or wireless communication with a compatible system. Using an in-built RF 868 MHz (Wireless radio frequency), or RS485 (Wired connection) communication method whilst being powered by a local 240V supply.

- Dimensions (HxWxD) (mm) 90 x 90 x 17
- Power supply 240V
- Temperature range 0~60°C
- Relative humidity range 0-90% RH
- Wireless range 20m closed/100m open
- RF 868MHz Wireless or RS485 Wired communication
- Compatible with standard single gang or surface mounted pattress box
- Status LED indicator for pairing, health check, faults & air quality traffic light index

Stock Ref  
**496429**



### CO<sub>2</sub>, Temperature and Humidity - Wireless - 240V

Room mounted CO<sub>2</sub> sensor for wired or wireless communication with a compatible system. Using an in-built RF 868 MHz (Wireless radio frequency), or RS485 (Wired connection) communication method whilst being powered by a local 240V supply.

- Dimensions (HxWxD) (mm) 90 x 90 x 17
- Power supply 240V
- Temperature range 0~60°C
- Relative humidity range 0-90% RH
- CO<sub>2</sub> Range 0-2000 PPM
- Wireless range 20m closed/100m open
- RF 868MHz Wireless or RS485 Wired communication
- Compatible with standard single gang or surface mounted pattress box
- Status LED indicator for pairing, health check, faults & air quality traffic light index

Stock Ref  
**496433**



### PIR Sensor - Wireless - 240V

Room mounted PIR sensor for wired or wireless communication with a compatible system. Using an in-built RF 868 MHz (Wireless radio frequency), or RS485 (Wired connection) communication method whilst being powered by a local 240V supply. Room mounted presence detector for min/max or on/off control. Wall or ceiling mounting.

- Dimensions (HxWxD) (mm) 90 x 90 x 17
- Power supply 240V
- 5-25min run on timer
- PIR Range 3m
- Compatible with standard single gang or surface mounted pattress box
- Wireless range 20m closed/100m open
- RF 868MHz Wireless or RS485 Wired communication

Stock Ref  
**496438**

# Lo-Carbon MVDC-MS/MSH Multivent

- Recognised in SAP PCDB with best in class Specific Fan Power
- Reduces your carbon footprint
- Fitted with three 125mm diameter extract spigots allowing quick connection to ducts
- Complies with Building Regulations ADF
- Option of wall, ceiling and loft mounting
- Improved controllability
- Two Switched Live connections
- Fully variable normal, purge and boost speeds
- Ultra quiet
- Integral humidistat (H version)



With growing concerns about accurate ventilation of properties, the Lo-Carbon Multivent MVDC range offers the option of 'Close Control' both in the residential and the commercial sectors. With a DC motor the multi speed Lo-Carbon Multivent is one of the most efficient central extract units available.

The units have 3 fully variable speeds: normal, boost and purge. The digital display allows accurate setting of airflow, ensuring exactly the right ventilation rate. Accurate speed control helps minimise noise and energy consumption.

The Multivent H version incorporates a built-in humidity sensor to boost the unit when humidity reaches a certain threshold.

## Dimensions (mm)

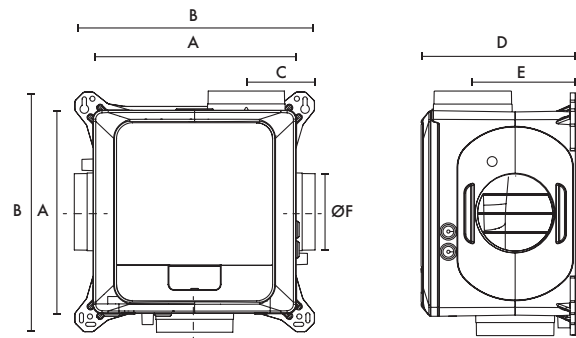

A	B	C	D	E	ØF	G	kg	No. Extract Spigots
330	391	111	248	165	125	-	4.1	3

## Models

Model	Stock Ref
MVDC-MS	437634C
MVDC-MSH	443298B

## SAP PCDB Test Results

Exhaust Terminal Configuration	Total Flow Rate (l/s)	SFP (W/l/s)
K + 1	21	0.15
K + 2	29	0.14
K + 3	37	0.16
K + 4	45	0.18
K + 5	53	0.21
K + 6	61	0.26

## Performance Guide

MVDC-MSH features an integral humidistat which triggers the unit to boost when humidity levels in the duct system exceed 70%.

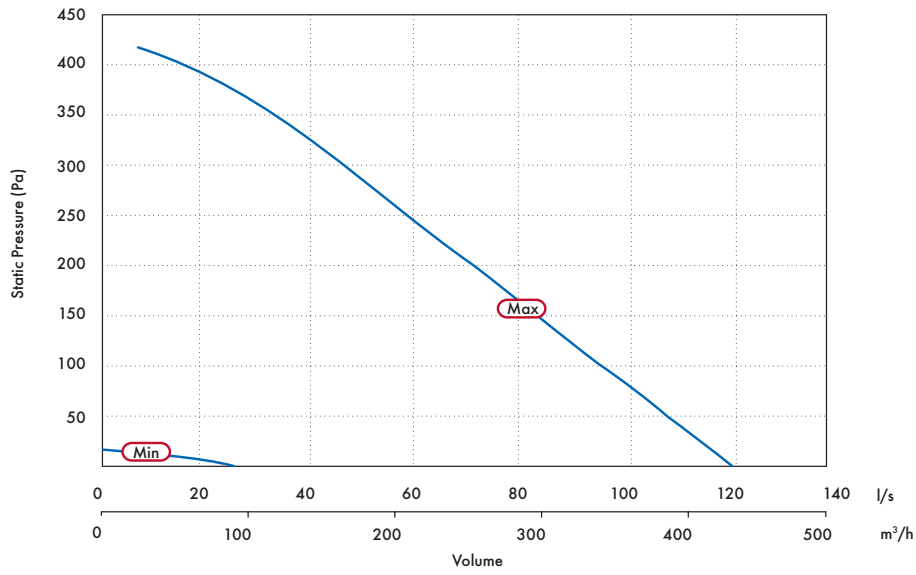

Min				Max				
Casing Breakout dB(A) @ 3m	Inlet Duct dB(A)	FID l/s	Power Watts	Casing Breakout dB(A) @ 3m	Inlet Duct dB(A)	FID l/s	Power Watts	SEC Class (inc. LDC)
13	18	24	2	37	40	118	44	B
13	18	24	2	37	40	118	44	B

## Sound Data

Speed	Test Mode	Octave Band (Hz) Sound Power Levels, dB								LwA	SpL @ 3m
		63	125	250	500	1k	2k	4k	8k		
20%	Extract	50.3	40.4	40.0	33.7	28.1	21.6	18.0	23.0	36.2	18.7
	Breakout	40.2	38.7	32.8	26.9	17.1	14.5	17.8	22.4	29.9	9.4
40%	Extract	58.4	52.9	52.4	46.2	41.5	30.4	20.8	23.1	48.2	30.7
	Breakout	42.7	44.7	45.3	33.0	24.3	19.7	17.9	22.4	37.5	17.0
60%	Extract	56.4	58.2	62.5	53.9	41.3	40.0	32.0	25.9	56.2	38.7
	Breakout	40.1	52.1	50.2	39.2	30.6	32.2	20.0	22.4	43.9	23.4
80%	Extract	60.1	63.9	67.2	63.8	48.4	46.2	41.6	35.0	63.1	45.6
	Breakout	33.6	60.1	47.4	49.6	36.1	32.7	24.2	22.7	49.2	28.7
100%	Extract	76.2	79.3	71.9	69.7	53.6	51.4	47.9	42.2	69.7	52.2
	Breakout	47.3	56.6	52.5	52.7	40.7	37.7	29.7	23.7	51.7	31.2

# Lo-Carbon MVDC-MSH Uniflex Multivent

- Recognised in SAP PCDB with best in class Specific Fan Power
- Reduces your carbon footprint
- Fitted with nine 90mm diameter extract spigots allowing quick connection to ducts
- Complies with Building Regulations ADF
- Option of wall, ceiling and loft mounting
- Improved controllability
- Two Switched Live connections
- Fully variable normal, purge and boost speeds
- Ultra quiet
- Integral humidistat



With growing concerns about accurate ventilation of properties, the Lo-Carbon Multivent MVDC range offers the option of 'Close Control' both in the residential and the commercial sectors. With a DC motor the multi speed Lo-Carbon Multivent is one of the most efficient central extract units available.

The units have 3 fully variable speeds: normal, boost and purge. The digital display allows accurate setting of airflow, ensuring exactly the right ventilation rate. Accurate speed control helps minimise noise and energy consumption.

The Multivent H version incorporates a built-in humidity sensor to boost the unit when humidity reaches a certain threshold.

The new Uniflexplus+ Semi-Rigid ducting range sets the standard for easy to install, low profile ducting solutions. The system gives all of the flexibility that semi-rigid ducting provides - without taking up vital space. With minimal components, the system is uncomplicated to ensure a hassle-free, speedy install.

## Dimensions (mm)

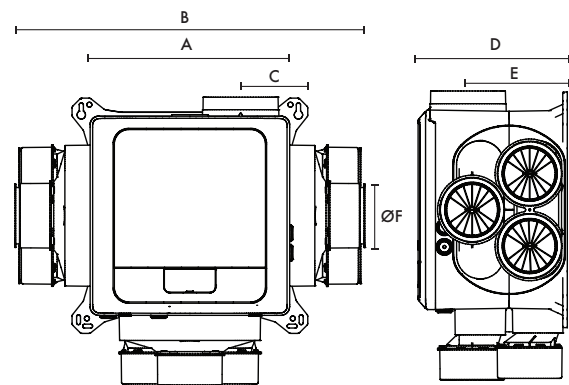

A	B	C	D	E	ØF	G	kg	No. Extract Spigots
330	567	111	248	165	90	479	7	9

## Models

Model	Stock Ref
MVDC-MSH Uniflex	498502

## SAP PCDB Test Results

Exhaust Terminal Configuration	Total Flow Rate (l/s)	SFP (W/l/s)
K + 1	21	0.15
K + 2	29	0.14
K + 3	37	0.16
K + 4	45	0.18
K + 5	53	0.21
K + 6	61	0.26

## Performance Guide

MVDC-MSH features an integral humidistat which triggers the unit to boost when humidity levels in the duct system exceed 70%.

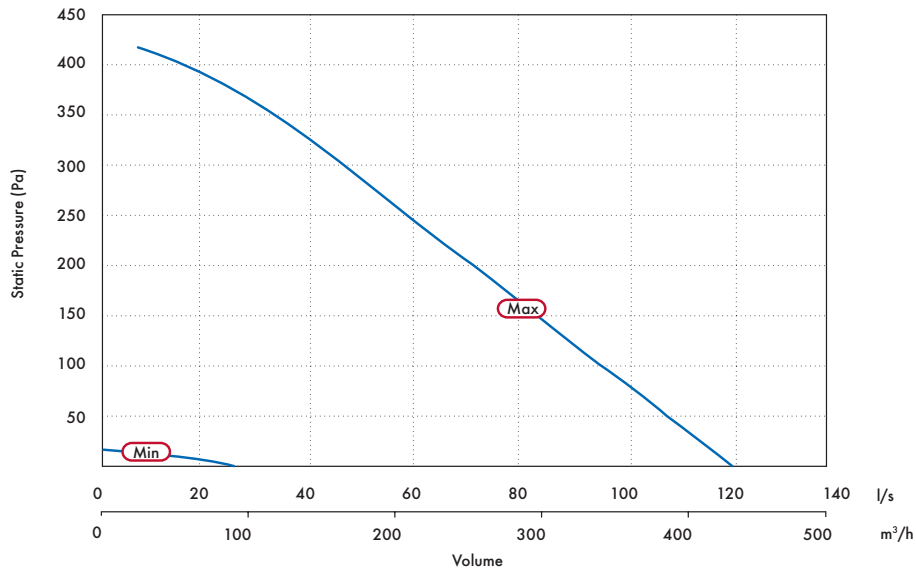

(Min)				(Max)				
Casing Breakout dB(A) @ 3m	Inlet Duct dB(A)	FID l/s	Power Watts	Casing Breakout dB(A) @ 3m	Inlet Duct dB(A)	FID l/s	Power Watts	SEC Class (inc. LDC)
13	18	24	2	37	40	118	44	B

## Sound Data

Speed	Test Mode	Octave Band (Hz) Sound Power Levels, dB								LwA	SpL @ 3m
		63	125	250	500	1k	2k	4k	8k		
20%	Extract	50.3	40.4	40.0	33.7	28.1	21.6	18.0	23.0	36.2	18.7
	Breakout	40.2	38.7	32.8	26.9	17.1	14.5	17.8	22.4	29.9	9.4
40%	Extract	58.4	52.9	52.4	46.2	41.5	30.4	20.8	23.1	48.2	30.7
	Breakout	42.7	44.7	45.3	33.0	24.3	19.7	17.9	22.4	37.5	17.0
60%	Extract	56.4	58.2	62.5	53.9	41.3	40.0	32.0	25.9	56.2	38.7
	Breakout	40.1	52.1	50.2	39.2	30.6	32.2	20.0	22.4	43.9	23.4
80%	Extract	60.1	63.9	67.2	63.8	48.4	46.2	41.6	35.0	63.1	45.6
	Breakout	33.6	60.1	47.4	49.6	36.1	32.7	24.2	22.7	49.2	28.7
100%	Extract	76.2	79.3	71.9	69.7	53.6	51.4	47.9	42.2	69.7	52.2
	Breakout	47.3	56.6	52.5	52.7	40.7	37.7	29.7	23.7	51.7	31.2



# Lo-Carbon NBR dMEV

- Market leading efficiency
- Digital controls with display
- Fully adjustable trickle & boost airflow settings
- 100mm & 125mm model
- Recognised in SAP PCDB
- Constant volume
- Display showing airflow and system pressure
- Switched live connection for external switches/sensors
- IPX5 rated
- Multi-orientation grille
- NHBC Approved
- STAS Approved (Scotland)
- Airflow sensor models UKAS calibrated



## Lo-Carbon NBR dMEV

Continuous running, constant volume dMEV range with switched live (LS) and innovative digital display and harmonised control platform. Quiet running and with high pressure development, the dMEV is best in class.

The unique patented display provides the calibrated installed airflow and pressure meaning that there is no need to test the installation with an airflow measuring device.

The constant volume technology automatically adjusts the speed of the fan to ensure the desired airflow is delivered. A silent high pressure axial impeller means Lo-Carbon dMEV can meet the requirements of many domestic installations without the need to use a traditional centrifugal fan.

A brand new control platform also provides fully adjustable airflow in 1l/s increments, meaning wholehouse rates can be achieved easily using fewer fans than is currently possible with any other dMEV product on the market.

## Longer Duct Runs

A new 125mm dMEV fan is also available to further improve Dwelling Emission Rates (DER) by improving efficiency and lowering noise. The larger 125mm spigot also means there are almost no restrictions in terms of duct lengths and bends used in the system, when compared to a traditional 100mm axial fan. This means fewer fans are required to achieve wholehouse ventilation rates.

As can be seen below, an axial dMEV fan consumes a fraction of the energy of the equivalent centrifugal fan - drastically reducing DER.

Configuration	Location	Alternative Centrifugal Fan SFP	Vent-Axia dMEV 125mm SFP
In room	Kitchen	0.38	0.16
	Wet Room	0.29	0.20
Through Wall	Kitchen	0.36	0.12
	Wet Room	0.28	0.16

## Side View of Airflow Display

Be confident that the dMEV is delivering the right performance with our innovative digital display showing the airflow and system pressure of the installed product.



## Comfort Control Option

Designed to offer a more relaxing environment to the homeowner, the Lo-Carbon dMEV features a delayed start option. This patented comfort control option is selectable at installation and allows the homeowner to enjoy a quiet, peaceful bathroom for up to 20 minutes before the Boost activates. Furthermore, if the light switch turns On and Off within 3 minutes, the Boost will not activate. No more disturbing the family if the bathroom light is turned on during the night.

## Lo-Carbon NBR dMEV & dMEV HT

Continuous running dMEV available in two sizes. Humidity control models incorporate an adjustable (40% - 90%) ambient response humidistat. The fan will increase the extract rate if the humidity rises above the point set at installation. Variable speed options for trickle and boost, dependant on size for maximum control. Features a display prism, to allow users to see airflow being achieved without having to remove a grille.

Variable Speed Settings (5-30 l/s trickle, 6-35 l/s boost)

Model	Stock Ref
Lo-Carbon dMEV 100 (Switch Live)	475142A
Lo-Carbon dMEV 100 HT (Humidity Control)	473809A

Variable Speed Settings (9-30 l/s trickle, 10-35 l/s boost)

Model	Stock Ref
Lo-Carbon dMEV 125 (Switch Live)	494147
Lo-Carbon dMEV 125 HT (Humidity Control)	494148

## Accessories

Model	Stock Ref
Wall Kit White 100mm	254102
Wall Kit Brown 100mm	254100
Ceiling Kit 100mm	407928
Window Kit 100mm	407927
Decoration Frame 100mm	474041
Wall Kit White 125mm	455226
Conversion Kit 150mm	408680

## Consultant Specification

The de-centralised mechanical extract ventilation unit shall be the NBR DMEV as manufactured by Vent-Axia, exact unit sizing and specification shall be in accordance with the particular specification.

The range should consist of IPX5 rated 100mm and 125mm sizes to meet the Building Regulations compliant design, extracting air from wet rooms (including kitchen and utility) via rigid, flexible ducting or through-wall applications with the fewest fans possible, supplied with a 7 year warranty.

The 100mm DMEV should have variable speed settings of 5-30 l/s on trickle and 6-35 l/s on boost, achieving a minimum noise level of 13 dB(A) at 3 metres. The 125mm DMEV should have variable speed settings of 9-30 l/s on trickle and 10-35 l/s on boost, achieving a minimum noise level of 12.9 dB(A) at 3 metres. All units shall be and independently 3rd party tested at the Sound Research Laboratory (SRL), tested to BS EN 13141-6.

The unit shall comprise a single high efficiency EC/DC motor to deliver specific fan powers as low as 0.12 w/l/s, as measured in accordance with the SAP PCDB test method and listed on the PCDB database.

The controls for the DMEV unit shall provide fully adjustable, continuous trickle and boost speeds, with the airflow being controlled in 1 l/s increments. The boost speed shall be activated via a switch live input or integral humidistat.

The unit shall include an integral humidity sensor with ambient and rapid response capability, which increases fan speed in proportion to the level of humidity detected. The unit shall also automatically raise the humidity threshold set point as temperature decreases in order to prevent unnecessary boosting due to background humidity levels.

The unit shall be able to be commissioned as a continuous running or intermittent fan according to the Building Regulations compliant design. The fan will have an in-built spirit level for ease of installation.

Commissioning of the fan in accordance with the Building regulations shall be achieved without the use of an airflow measuring device. The fan shall be provided with a UKAS calibrated, constant volume function with the flow rates displayed on the unit without having to remove the cover via the display prism.

## Dimensions (mm)

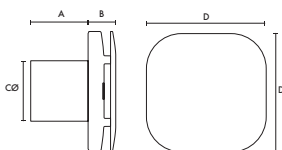

Model	A	B	CØ	D
100	81	43	99	190
125	100	46	115	213

## Performance Guide

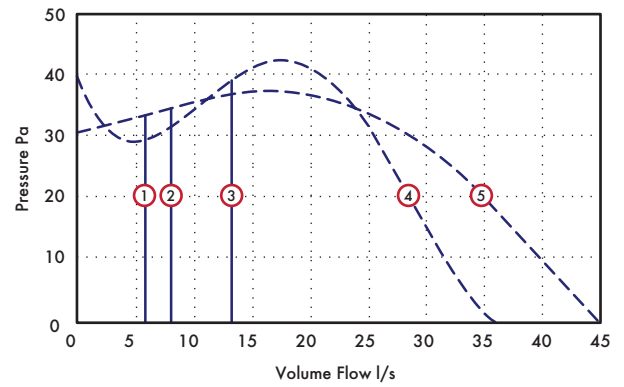

- ① 6l/s Constant Volume
- ② 8l/s Constant Volume
- ③ 13l/s Constant Volume
- ④ Maximum pressure available to deliver airflow - 100mm model
- ⑤ Maximum pressure available to deliver airflow - 125mm model

## Sound

Flow l/s	100mm					Flow l/s	125mm				
	Min	6	8	13	Max		Min	9	13	15	Max
Pa	-	5	7	17	-	Pa	-	4	7	9	-
dB(A)	13	14	17	24	41	dB(A)	12	14	17	19	36

## SAP PCDB Performance

Unit Configuration	Location	100 Model	125 Model
In room (rigid duct)	Kitchen	0.17	0.16
	Wet room	0.17	0.20
In room (flex-duct)	Kitchen	0.16	0.15
	Wet room	0.16	0.20
Through wall	Kitchen	0.12	0.12
	Wet room	0.14	0.16

# Lo-Carbon PoziDry Pro™

- Anti-vibration joist mounting legs as standard
- Fully adjustable between 19l/s - 49l/s
- Smart Sense™ Technology offers simple control and data logging
- Uses latest Lo-Carbon motor technology for low running costs
- Ultra low sound level
- Complete with ceiling diffuser, flexible duct and G4 filters with F7 upgrade option
- IPX2 rated



Some parts of this product are made using recycled material therefore the colour of the plastic may vary from white to black. To find out more please visit [www.vent-axia.com/sustainable](http://www.vent-axia.com/sustainable)

## Positive Input Ventilation

Designed to prevent and treat condensation and mould quickly. The PoziDry Pro™ is the perfect solution for general refurbishment, as its discreet, easy to install and almost silent running.

Lo-Carbon PoziDry Pro™ offers a quick and simple solution. A loft mounted positive input fan draws fresh air from the loft, filters it and gently feeds it into the dwelling via a ceiling mounted diffuser. Clean, fresh filtered air with a lower moisture content dilutes, displaces and replaces, contaminated and moisture laden air.

## Installation

The Lo-Carbon PoziDry Pro™ is uniquely flexible in its installation methods, high sided anti-vibration legs and a hanging kit both come as standard, allowing the PoziDry Pro™ to be installed quickly in any sized loft. The easy carry handle incorporated into the body makes carrying the unit easy and safe; especially useful when lifting the unit through loft hatches.

The unit is supplied with a purpose designed diffuser to be located over the stairwell of a conventional dwelling, in the main hall of a bungalow, in the landing or hallway. The 4-point contact easy fit technology allows fast and repeatable 'drill free' installation.

Using Smart Sense™ Technology the unit is easily set to the appropriate speed at installation based on the size of the dwelling. Natural leakage points that are present in all dwellings, as well as purpose provided exhaust points enhances the air change. En-suites and utility areas should be serviced by continuous mechanical extract ventilation.

The PoziDry Pro™ can also be set to 'Radon' mode in properties that are affected by high radon gas levels. The unit will run continuously to ensure the constant supply of good indoor air to protect residents from harmful gases.

## Performance

With a lightweight construction, the Lo-Carbon PoziDry Pro™ features a specially developed Lo-Carbon DC fan/motor arrangement which runs quietly and delivers incredibly low running costs. The Lo-Carbon PoziDry Pro™ uses a sensor to monitor the temperature in the loft, automatically adjusting the air volume when necessary. Additionally, resident comfort can be assured through an option to change the temperature at which the unit increases or decreases airflow. The unit will continuously ventilate silently in the background whilst in 'Trickle' mode. Once the unit automatically senses excess heat being lost into the loft the airflow will increase to 'Energy Recovery' mode to recover heat that would otherwise be lost through the roof. During summer months should the loft exceed 27°C (adjustable) the unit will enter 'Stand-by' mode in order stop the circulation of warm air allowing for a more comfortable living environment. PoziDry Pro™ Heater models automatically turn on the 500W heater to help take the chill off the incoming air.

## Filter

Standard filters supplied with the PoziDry Pro™ are G4 (PM10 filtration) which filter out many every day pollutants such as pollen and dust. Optional F7 filters are available (PM2.5 filtration) removing tobacco smoke, diesel particulates, spores and a number of bacteria.

## Data Logger

Smart Sense™ Technology allows the unit to record how long it has been running in each of its speeds. It also measures the number of days the product has been switched on to provide precise running information. Smart Sense™ Technology can also record the duration of heater activity and energy used.

## Speed Control

Smart Sense™ Technology makes speed selection easy. Once house size is selected based on number of bedrooms, PoziDry Pro™ automatically selects the correct 'Trickle' and 'Energy Recovery' speeds. Should you need to adjust speed manually this can be done easily. The Smart Sense™ interface can also be locked ensuring that settings are not tampered with.

## Heater

The heater model comes with a 500W heater attached to the unit. Smart Sense™ controls allow the PoziDry Pro™ to be adjusted fully when the heater is activated making it adaptable for all lifestyles.

## Air Replacement Grille Set\*

This set is for air replacement through doors. Consists of a two-piece telescopic set, which fits unobtrusively on either side of the door panel. Minimum fixing thickness 30mm. Plastic. Dimensions: 454 x 90mm.

\*Only required if there is not a 10mm undercut on the internal doors.

## Mounting Options

PoziDry Pro™ comes as standard with both high sided anti-vibration legs and a hanging kit. The legs are designed to mount between standard joist widths between 300-650mm. Clip and fit connections allow for easy installation.

## Motor

The electronically controlled DC motor is manufactured with long life ball bearings and is fitted with Overload Protection. Suitable for ambient operating temperatures of -25°C to +40°C. For complete peace of mind, the Vent-Axia Lo-Carbon PoziDry Pro™ is backed by a 5 year warranty.

## Discreet Diffuser

The discreet circular diffuser\*\* is easily installed, fitted and maintained. Easy fix features it can be installed against uneven ceiling surfaces with no gaps. Its low profile and aesthetically pleasing design has been developed with tenant acceptability in mind. The Smart Air™ Technology reduces air supply noise while increasing performance by 10%. The easy clip blanking plates help to control airflow into the property.

\*\*Diffuser will always be supplied using white plastic.

## Models

All models come with G4 filter, 2m of flexi duct and Ø200mm Diffuser. The Pozi Dry Pro™ FD model diffuser is fire rated but does not include Smart Air™ Technology.

### PoziDry Pro™

Stock Ref

476310

### PoziDry Pro™ with Heater

Stock Ref

476311

### PoziDry Pro FD with Heater (Multi-storey Compliant)

Stock Ref

476312

## Accessories

Model

Stock Ref

### Twin Spigot Kit

449071

An additional kit to allow an extra circular diffuser to be installed near the PoziDry unit. The kit includes 1 x Ø200mm 6m Duct, 2 x Worm Clips, 1 x Ø200mm Equal Y Piece and 1 x Diffuser.

### Interconnecting cable for boost switch

411150

Diffuser

478228

F7 Filter Set

477957

G4 Filter Set

477629

Air replacement grille set - Brown

561400

Air replacement grille set - Ivory

561401

## Dimensions (mm)

A*	B	C	D	ØE	F	G	ØH	I**
300-650	425	365	330	200	530-570	300	220	400-600

\*Variable to adapt to differing joist widths. \*\* Variable to allow for adapting product height

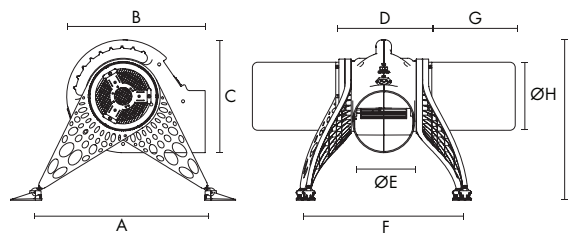

## Performance Guide

Bedroom	Trickle		Energy Recovery	
	Flow Rate (l/s)	Power (W)	Flow Rate (l/s)	Power (W)
1	19	3.1	29	5.1
2	25	4.3	37	7.6
3	31	6.0	46	12.0
4	37	8.0	49	13.1
Adjustable	19-48	-	20-49	-

# Lo-Carbon PoziDry Compact Pro

- Ultra small unit can fit in the smallest of spaces
- Removable inner cartridge for easy repairs and maintenance
- Flow rates adjustable in 1l/s increments, up to 30l/s
- Extremely low energy consumption
- Washable, high capacity G4 or F7 filter
- Advanced data logger and 3 digit settings lock for peace of mind
- 7 year warranty
- Ideal solution for flats with mould in a habitable room



## Positive Input Ventilation

For those properties that do not have a loft, the Lo-Carbon PoziDry Compact Pro provides an easy to install solution. The unit has been designed to be as small as possible with multiple inlet and outlet positions allowing it to be installed in the best place every time.

Air is drawn into the Lo-Carbon PoziDry Compact Pro unit via an external inlet and through a short length of duct. The specially developed power pack cartridge assembly draws the air through an integral, high capacity, washable filter. The precision engineered scroll/impeller assembly and anti-vibration EPP body guarantees ultra low sound levels and increased energy efficiency.

The fresh, filtered airflow passes along the ducting and enters the room through a discreet grille. The rotatable integrated grille can be turned to one of 8 positions ensuring that the airflow is always directed upwards, reducing cold draughts.

The system provides fresh, tempered air into the home and creates an indoor environment where the damaging effects of condensation find it hard to exist, benefiting both the occupants and the structure of the building.

## Performance

If the ambient temperature exceeds 27°C, the Lo-Carbon PoziDry Compact Pro will automatically switch off to prevent over-heating. This temperature threshold can be adjusted at installation.

In the case of the integral 300W heater version, the heater element is automatically activated when necessary and tempers the supply air to a chosen temperature.

## Peace of Mind

Smart Sense™ technology records usage, energy consumption and filter life to ensure the unit has been used as intended. This is secured by an installer enabled 3 digit settings lock to make the PoziDry Compact Pro tamper free.

## Model

With integral heater  
Stock Ref  
**479188**

## Accessories

Model	Stock Ref
ABS Spare Cover	479843
Spare Boxing Cover	479849
Spare Boxing Cover with Grille right	479850
Spare Boxing Cover with Grille left	479851
Boxing 200mm x 200mm x 2m	479852
Boxing End Stop	479853
Boxing End Stop with Grille	479854
Boxing Inner Bend	479855
Boxing Outer Bend	479856
Silencer Kit	479857
Acoustic Flexi Duct	443273
Spare Scroll Cartridge	479859
Spare PM10 Filter	479860
Spare PM2.5 filter	479861

## Dimensions (mm)

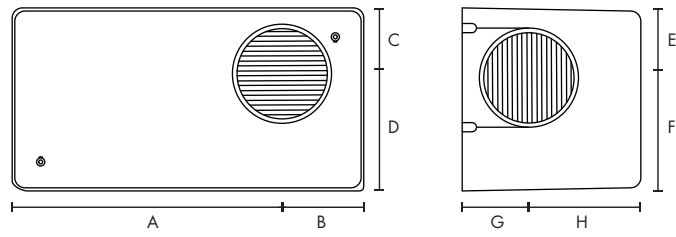

A	B	C	D	E	F	G	H	Spigot Ø	Unit Weight
302	91	74	132	79	127	75	125	100	3kg

## Performance Guide

No. Bedrooms	Not Ducted (l/s)	Power (W)*	Ducted (l/s)	Power (W)
1	19	9	19	11
2	25	18	25	18
LS/Boost	25	18	25	18



# Residential & Commercial dMVHR

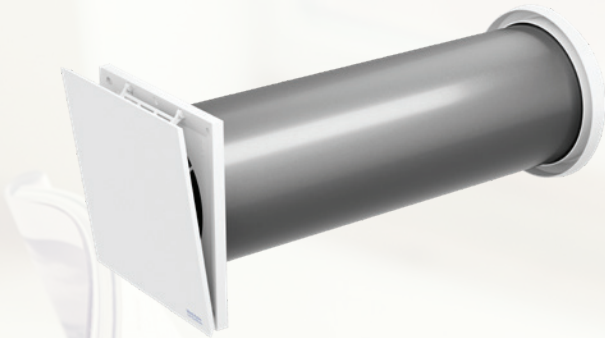

Improving air quality on a room-by-room basis, the Vent-Axia through-the-wall mounted range of heat recovery ventilation units simultaneously extract stale air and introduce fresh air - warming the incoming airflow with heat recovered from the exhaust stream.

## **Vent-Axia Lo-Carbon Heat Save**

A reversible fan which extracts dirty air from the room and replace it with outside air 70 seconds later. This air passes through a filter to ensure that clean air enters the room. These systems work best in pairs as when one unit is extracting, the other can be supplying air to provide a balanced ventilation system. They are controlled by a SENWZP Sentinel wired zone controller which can operate up to 8 units in synchronization. This provides a single room or whole house balanced ventilation system with heat recovery.

As well as filtering the air, the Vent-Axia Lo-Carbon Heat Save uses a thermal accumulator to extract warmth from the outgoing air and uses it to temper the incoming air to avoid the feeling of cold drafts and recover heat that would otherwise be lost to the outside.

**Vent-Axia**<sup>®</sup>

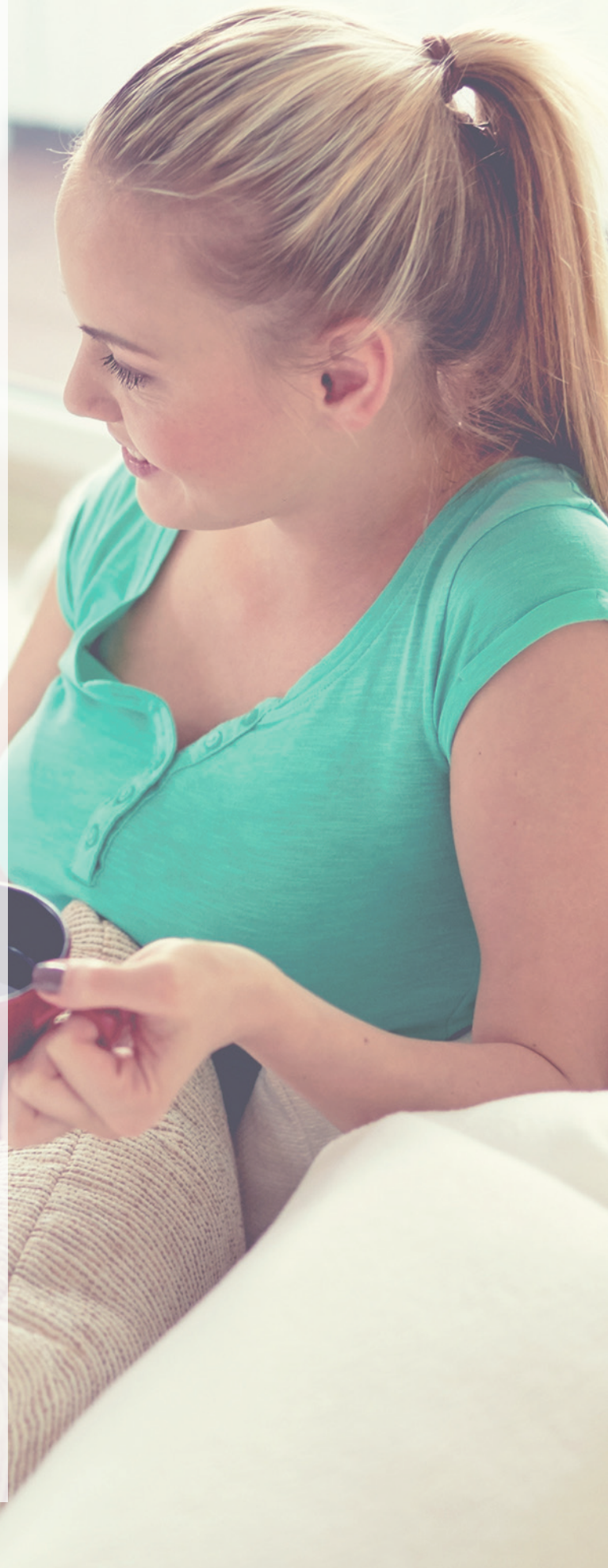



Lo-Carbon Calido

C3-C4

---

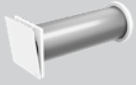

Lo-Carbon Heat Save/Alternate Flow Heat Recovery

C5-C6

---



Lo-Carbon Tempra/SELV

C7-C8

---



HR200WK/WJ

C9-C10

---

# Vent-Axia Lo-Carbon Calido

- Up to 80% heat recovery to reduce energy bills
- Reduce the home's carbon footprint and save money on energy bills
- Ideal for retrofit applications
- Intelligent controls to eliminate condensation within the unit
- Adjustable airflows
- Filter replacement indicator ensures continuous good indoor air quality
- Incredibly reliable due to EC motor
- CE and S Mark - independently tested and certified for safety
- IP24 rated
- 5 year warranty



## Discrete Whole House Heat Recovery

The Vent-Axia Lo-Carbon Calido is designed to remove stale air from any habitable room and replace it with fresh air. This unit is designed to be ducted therefore it can benefit more than one room at a time i.e. if installed in a bathroom, stale and moist air will be extracted and fresh air will be supplied to other habitable rooms via installed ducting.

The Vent-Axia Lo-Carbon Calido offers up to 80% heat recovery which helps reduce the amount of heat lost from the property. This helps save money by reducing energy costs as well as reducing carbon emissions. The unit cleverly recovers heat from heat lost through extraction and reuses it to warm the air re-entering the property.

One unit can help improve the air quality of a whole house and with changeable filters it can help provide clean air all year round. With three air flow options available, the Vent-Axia Lo-Carbon Calido can be installed in many types of properties and its compact design means it will ventilate and recover heat quietly in the background. It can also be wall or ceiling mounted depending on space availability, making it perfect for many retrofit applications.

---

## Models

### Vent-Axia Lo-Carbon Calido

The Vent-Axia Lo-Carbon Calido is a robust unit with an IP24 rating and is double insulated for extra protection. It uses an EC motor, which is incredibly reliable and comes with a five year warranty.

**Stock Ref**  
**411133**

---

## Accessories

### Model

Filter kit standard G4 2pcs

External wall kit 100mm

Exhaust air adaptor

Calido Controller

### Stock Ref

**411156**

**411163**

**411164**

**411331**

---

## Typical Installation

The Vent-Axia Lo-Carbon Calido requires two 100mm diameter holes - one to extract stale air and one to intake fresh air. It also comes with a drilling template for an easy install.

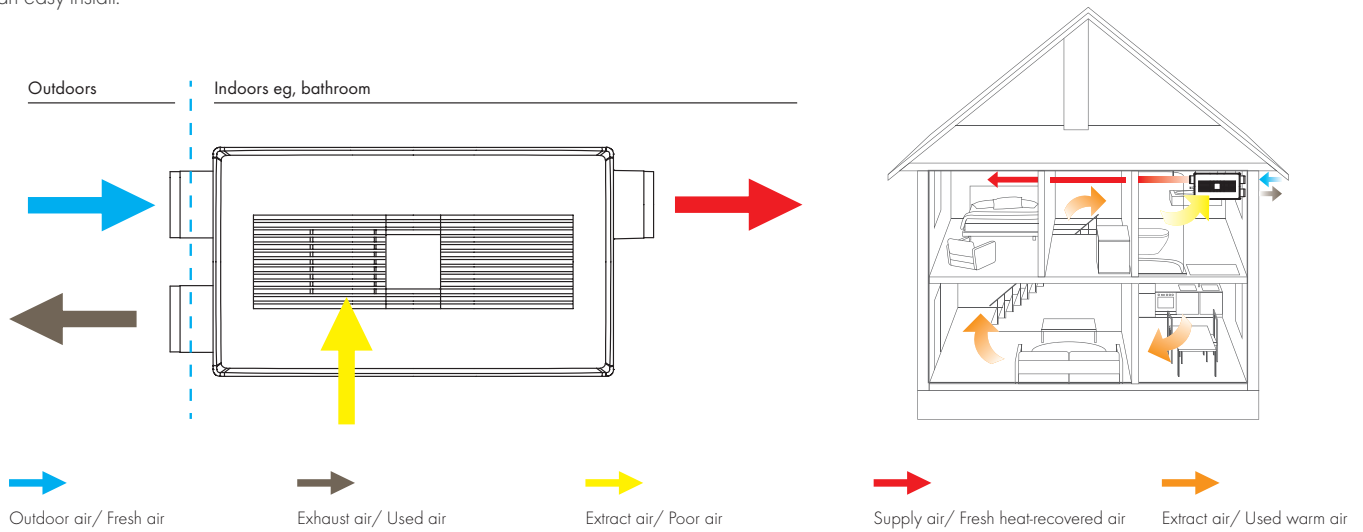

## Dimensions (mm)

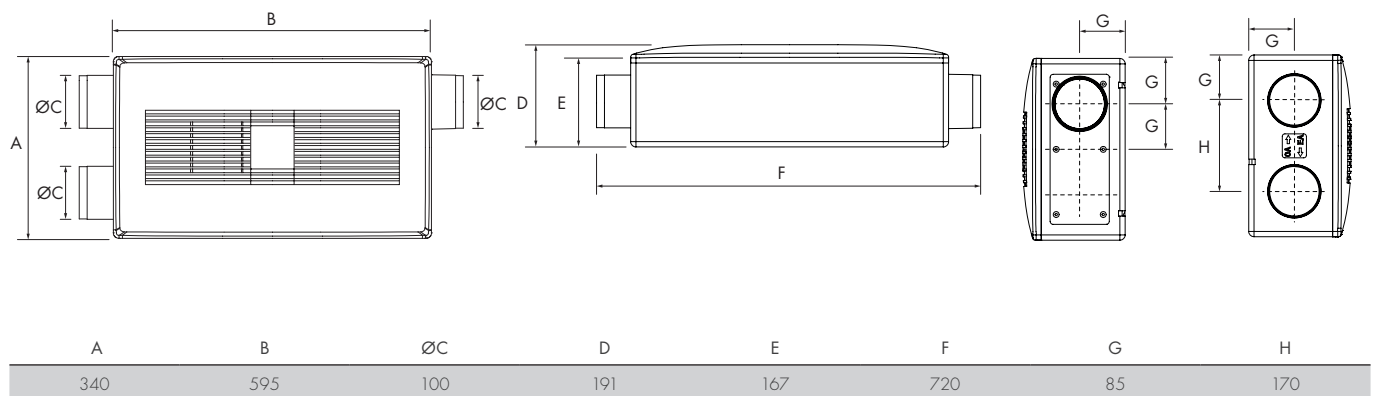

## Performance

Wall opening:	100 mm
Balanced Air flow:	8.3 - 25 l/s
Power consumption:	3.5 - 25W
Sound emission:	19 - 35 dB(A)
Heat Recovery:	80%
Temperature range:	-30 - 35 °C

# Vent-Axia Lo-Carbon Heat Save

- Suitable for improving indoor air quality in habitable rooms
- Fully customisable ventilation via a control panel
- Easy to install, no need for ducting, wall sleeve included
- Easily maintained with cleanable filter and ceramic heat exchanger
- 5 year warranty for peace of mind
- Up to 84% heat recovery to reduce energy bills
- Anti-frost protection built in
- Replace extracted air with filtered air
- Reduce the home's carbon footprint and save money on energy bills

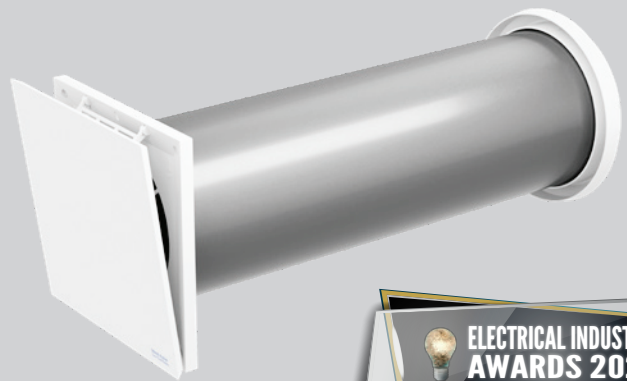

## Through-The-Wall Heat Recovery Unit

The Vent-Axia Lo-Carbon Heat Save is a ventilation unit designed for living rooms and bedrooms in single and multi-family buildings. The unit is usually located in an exterior wall to provide new air to the room.

The Vent-Axia Lo-Carbon Heat Save uses a reversible fan to extract dirty air from the room and replace it with outside air 70 seconds later. This air passes through a filter to ensure that clean air enters the room. These systems work best in pairs as when one unit is extracting, the other can be supplying air to provide a balanced ventilation system. They are controlled by a SENWZP Sentinel wired zone controller which can operate up to 8 units in synchronization. This provides a single room or whole house balanced ventilation system with heat recovery.

As well as filtering the air, the Vent-Axia Lo-Carbon Heat Save uses a thermal accumulator to extract warmth from the outgoing air and uses it to temper the incoming air to avoid the feeling of cold drafts and recover heat that would otherwise be lost to the outside.

## Models

### Vent-Axia Lo-Carbon Heat Save

Decentralised ventilation system with up to 84% heat recovery. Compact design for apartments or houses with 180mm diameter, ideal for refurbishment. Includes reversible fan with a thermal accumulator, external wall grille, wall sleeve, dust filter. Requires 1x SENWZP (496037) wired zone controller per installation of 8 units.

Stock Ref  
**496036**

## Accessories

### Model

	Stock Ref
Sentinel Wired Zone Control Panel (SENWZP)	496037
Spare Inner Cover 220x220	496108
Heat Save PM10 ISO Coarse 60% (formerly G4) filter	496038
External Wall Sleeve 160x745	495328
Spare Wall Sleeve 160x495	496105
Spare Reversible Fan	496110
Spare Thermal Accumulator	496111
Spare Weather Protection Grille	496107
Sound Absorbing Insert	496109

## Performance

Wall opening:	167 - 180 mm
Wall thickness with plaster/render:	>290 mm
Supply Air flow:	2.8 - 12.0 l/s
Extract Air flow:	2.8 - 12.0 l/s
Average Air flow:	1.4 - 6.0 l/s
Power consumption:	1 - 3W
Sound emission:	18 - 36 dB(A)
Heat Recovery:	84%
Temperature range:	-20 - 50 °C

## Typical Installation

The Vent-Axia Lo-Carbon Heat Save can be fitted in a 167mm - 180mm diameter hole. Maximum wall thickness is 460mm or 745mm with optional wall tube (see accessories). The wall sleeve length (included up to 460mm) can be cut down to size to fit any wall thickness.

Vent-Axia Lo-Carbon Heat Save units work best in pairs. When one unit is extracting, the other can be supplying air to provide a balanced ventilation system. They alternate direction every 70 seconds when the thermal accumulator on the extract unit has warmed up allowing the supply air to benefit from these thermal gains. They are controlled by a SENWZP Sentinel wired zone controller. This is fully modular and controllable with customised ventilation profiles available so that every room in the home can have the perfect ventilation.

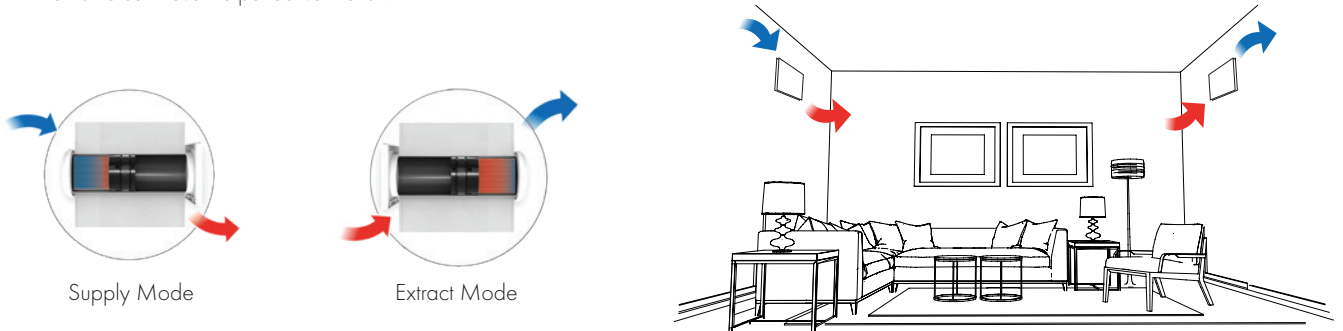

## Dimensions (mm)

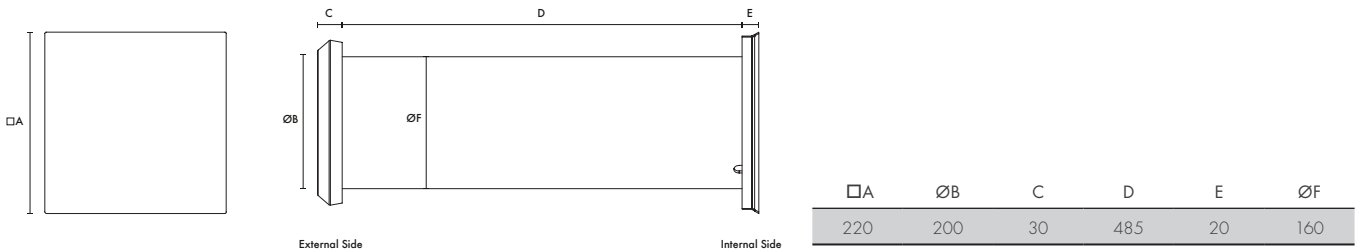

## Sound @ 1m dB(A)

Fan Speed	With sound absorbing insert	Without sound absorbing insert
25%	20.0 dB(A)	16.8 dB(A)
35%	23.0 dB(A)	20.8 dB(A)
50%	30.7 dB(A)	26.3 dB(A)
75%	37.0 dB(A)	Not tested
100%	43.0 dB(A)	33.7 dB(A)



# Lo-Carbon Tempra/SELV

- Fits in 100mm diameter hole - ideal for refurbishments
- Up to 78% heat recovery
- Available in 2 wall depths: 320mm and 460mm
- Reduces the home's carbon footprint
- IPX4 rated
- Summer setting (extract only)
- Helps prevent noise ingress
- Continuous running or intermittent extract
- Meets current Building Regulations Approved Documents F and L
- Low power consumption - only 3.2 W



## Through-The-Wall Heat Recovery Unit

The Vent-Axia Lo-Carbon Tempra is designed to fit in 100mm diameter hole and is suitable for refurbished properties in kitchens, bathrooms, toilets or utility rooms. The unit meets the performance requirements for continuous extract fans under the current Building Regulations Approved Document F.

The Tempra is available in three models, a P version with pullcord control, a T version with overrun timer and an HTP version with built-in pullcord, overrun timer and humidistat. Two spigot lengths are available; 320mm and 460mm.

The manual summer setting allows the unit to be set to extract only, helping to prevent a dwelling becoming too warm in hot summer conditions.

## Performance

The Tempra can be set to run continuously at 6 l/s or 9 l/s, boosting up to 15 l/s, recovering heat from extracted air and returning it to the dwelling. The unique, compact heat exchanger has a temperature efficiency up to 78%, saving energy and reducing your carbon footprint. For intermittent extract the Tempra is set to 15 l/s.

Tempra is also designed so that the replacement air being introduced is at a reduced rate ensuring that the room being ventilated is still under a slight negative pressure. This ensures that fresh air is brought into the room from the rest of the house preventing humid air migrating.

The Lo-Carbon EC/DC motor with twin impellers consumes as little as 3.2 Watts on trickle rate and runs almost silently at only 20dB(A).

## Typical Installation

The unique heat exchanger design allows the Tempra to be fitted in a 100mm diameter hole, allowing it to replace standard 100mm extract fans while giving all the benefits of heat recovery. Maximum wall thickness is 460mm.

A longer version of the Tempra is available, designed for installations where the wall thickness is between 321mm and 460mm. 460mm models are identified by an 'L'.

## Models

### Lo-Carbon Tempra P (Pullcord)

Constant trickle speed with pullcord to boost or intermittent operation by pullcord.

Model	Stock Ref
320mm P	443312
320mm SELV P	444368
460mm LP	403832
460mm SELV LP	403833

### Lo-Carbon Tempra T (Timer)

Constant trickle speed with switch live to boost or intermittent operation by switch live.

Model	Stock Ref
320mm T	443310
320mm SELV T	444369
460mm SELV LT	403835

### Lo-Carbon Tempra HTP (Humidistat/Timer/Pullcord)

Constant trickle speed with humidistat and linked overrun timer to boost or intermittent operation by switch live.

Model	Stock Ref
320mm HTP	443311
320mm SELV HTP	444370
460mm LHTP	403836
460mm SELV LHTP	403837

## Accessories

### 100mm High Rise Kit

320mm white duct with black seal.

Model	Stock Ref
100mm High Rise Kit	449011

### Wall Kit

Extendable Wall Tube suitable for both spigot lengths.

Model	Stock Ref
Wall kit	445529

150mm Conversion Kit  
 For replacement of 150 diameter fan.  
 Stock Ref  
**403847**

**Dimensions (mm)**

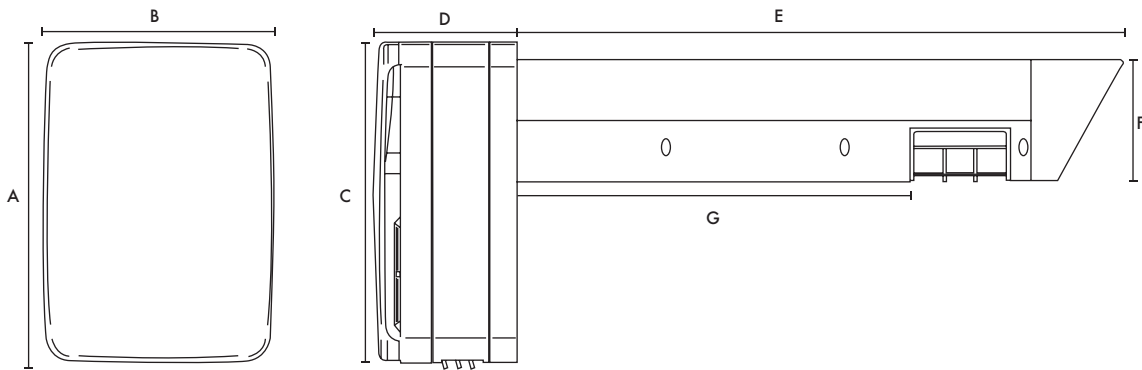

	A	B	C	D	E	F	G
Standard	266	190	262	117	496	99	321
Long	266	190	262	117	636	99	461

**Performance**

Model	Extract Performance l/s			Power Consumption Watts			Sound @dB(A)*		
	Trickle Low	Trickle High	Boost	Trickle Low	Trickle High	Boost	Trickle Low	Trickle High	Boost
Lo-Carbon Tempra (All Models)	6	9	15	3.2	5.7	26.6	20	22	36

\*Octave band frequency range of 250Hz to 4KHz at 3m. Unit mounted on a reflective surface.

**Heat Exchange - what is heat recovery?**

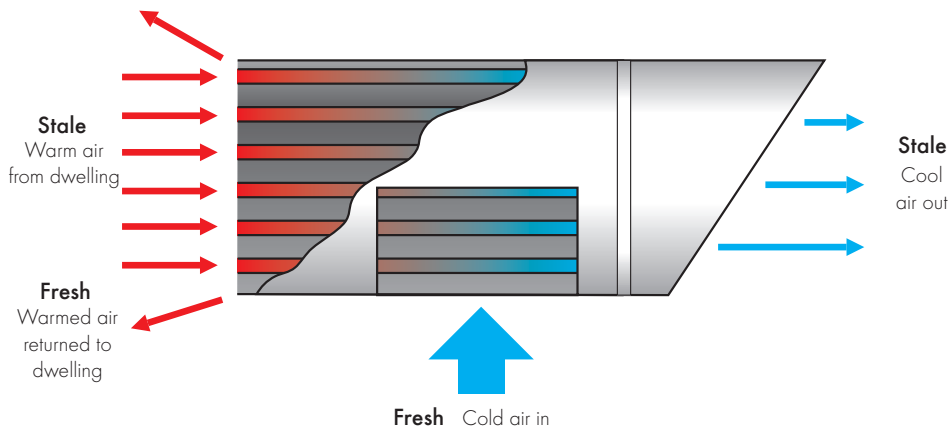

# HR200WK/WJ

- Single room domestic heat recovery ventilation unit
- 3 speed motor
- Integral washable filter
- Up to 75% heat recovery
- Saves energy - controls condensation
- Low noise



## Heat Recovery Ventilation

### HR200WK

The Vent-Axia HR200WK is a heat recovery ventilation unit specifically designed for use in domestic kitchens and utility rooms to meet the Building Regulations. The unit is also suitable for light commercial applications up to 61l/s (220m<sup>3</sup>/h).

### HR200WJ

Developed for lower flows and lower noise, the HR200WJ is ideal for single living accommodation, for example student accommodation or care homes.

The three speed, external rotor motor has two matched impellers to ensure a controlled airflow through the unit, with exceptionally economical 25 Watt low speed power consumption.

The compact, self-contained unit is designed for through-the-wall mounting.

## Easy Installation

The units fit through walls up to 335mm thick requiring a fixing hole 250mm square. The internal grille has washable, polymeric foam supply and extract filters. Only the neat internal twin grille is visible from the room. A wall extension sleeve is available for walls up to 550mm thick.

## Heat Exchanger

The highly efficient, polymeric heat exchanger cube is washable. The compact cube interleaves outgoing moist warm air with incoming fresh air and allows the heat from one to warm the other without the two air streams mixing. Up to 75% of the heat, which would otherwise be lost, is transferred to the intake air, ensuring energy saving ventilation.

## Electrical

HR200WK/WJ 220-240V/1/50Hz Class 1 earthed appliance. The 3 speed motor, can be wired to operate On/Off for any one of the three speeds. Alternatively, an Ambient Response Humidity Sensor or simple

changeover switch can be used to provide switching between any two speeds, giving permanent trickle ventilation and automatic changeover to a higher speed during periods of high moisture generation. Also the 3 speed controller enables the unit to be switched from permanent trickle to either medium or boost speed.

## Models

### HR200WK

A heat recovery unit specifically designed for use in domestic kitchens and utility rooms to meet the latest Building Regulations. Main body colour; Dark Brown.

Stock Ref  
**14120020**

### HR200WJ

Lower air-flows mean this unit is ideally suitable for residential applications such as care homes and student accommodation. Main body colour; Dark Grey. 3 speed motor, trickle ventilation mode, optional range of switches available.

Stock Ref  
**479118**

## Accessories

Model	Stock Ref
Extension Wall Sleeve	<b>370421</b>
Electronic Controller	<b>W300310</b>

## SEC Class

Model	SEC Class	SEC Class (inc. LDC)
HR200WK	C	A
HR200WJ	C	A

## Dimensions (mm)

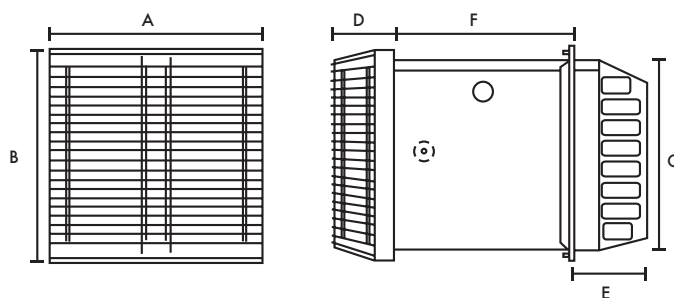

Wall fixing hole 250mm x 250mm sq.

A	B	C	D	E	F
270	270	245	85	68min	335max

Weight 9.7kg

## Performance

Model		Performance l/s (m <sup>3</sup> /h)			% Heat Recovery	Sound dB(A) @ 3m
		Extract	Intake	Watts		
HR200WK	Speed 1	16 (60)	13 (50)	25	75	19
	Speed 2	30 (110)	27 (100)	60	70	33
	Speed 3	61 (220)	55 (200)	140	65	46
HR200WJ	Speed 1	8 (28)	5 (19)	9	75	18
	Speed 2	14 (52)	9 (34)	18	75	18
	Speed 3	28 (100)	18 (64)	51	70	31

# MVHR for Residential & Commercial Applications



Vent-Axia offers a complete range of Mechanical Ventilation with Heat Recovery (MVHR) units for residential and commercial applications, including many that are recognised in the SAP Product Characteristics Database.

## **Lo-Carbon Sentinel Econiq**



The latest flagship mechanical ventilation with heat recovery system. Designed and developed in the UK, it offers the highest level of comfort and functionality all year round.

Introducing a full range of products, with air performance suitable for all types of homes. Our new Sentinel-X controls platform delivers complete control over your ventilation environment. Provided through a full range of wired/wireless sensors and smartphone app.

**Vent-Axia**<sup>®</sup>





	Lo-Carbon Sentinel Kinetic Range Overview	D3-D6
	Lo-Carbon Sentinel Econiq Passivhaus Certified MVHR Unit	D7-D14
	Lo-Carbon Sentinel Econiq MVHR Unit	D15-D22
	Lo-Carbon Sentinel Kinetic MVHR Unit	D23-D26
	Lo-Carbon Sentinel Kinetic FH MVHR Unit	D27-D30
	Lo-Carbon Sentinel Kinetic Plus MVHR Unit	D31-D34
	Lo-Carbon Sentinel Kinetic High Flow MVHR Unit	D35-D38
	Lo-Carbon Sentinel Kinetic Cooker Hood MVHR Unit	D39-D42
	Lo-Carbon Sentinel Kinetic Horizontal MVHR Unit	D43-D48
	Integra Horizontal MVHR Unit	D49-D50
	Integra Plus EC Horizontal MVHR Unit	D51-D52
	HR100R/RS Horizontal MVHR Unit	D53-D54
	HR500 Single Room Heat Recovery Unit	D55-D56
	HR500D Ducted MVHR Unit	D57-D58
	HR500EP/IP Passive HR Unit	D59-D60
	HR500DP Passive HR Unit	D61-D62



# Lo-Carbon Sentinel MVHR Range Overview

- Manufactured in the UK
- Building Regulations ADF and ADL compliant
- Recognised in SAP PCDB
- Specific Fan Power down to 0.4 W/l/s
- Up to 93% heat recovery
- Fully automatic Summer bypass
- Horizontal and/or vertical duct outlets
- Integrated digital controller for simple and accurate commissioning
- Lightweight for easy installation
- External condensate connection
- Plug and play controls; Humidistat
- Acoustic Enclosure option for reduced breakout noise
- Acoustic Top Box option for reduced in-duct noise



## The Sentinel Kinetic Range Incorporates:

- A wholehouse heat recovery system with up to 94% energy efficiency
- An easily accessible heat recovery cell protected by two removable ISO 45% Coarse (G3) filters
- Two Lo-Carbon energy saving EC/DC fans which ensure long life (typically over double the life of AC motors) and lowest possible energy use
- Fully insulated construction with built-in condensation drain
- Specifically designed for new build constructions with a high level of insulation

The Lo-Carbon Sentinel Kinetic meets the latest requirements of the Building Regulations ADF and ADL for wholehouse system ventilation: Continuous mechanical supply and extract with heat recovery. The Lo-Carbon Sentinel Kinetic models have 3 fully adjustable speeds and a purge setting (maximum flow). Provided with the unit is a digital controller that can be used to preset the speeds to any required airflow within the performance range.

## Integral Humidity Sensor

The integral humidity sensor (models with H suffix) increases speed in proportion to relative humidity levels, saving energy and reducing noise. The sensor also reacts to small but rapid increases in humidity, even if the normal trigger threshold is not reached. This unique feature ensures adequate ventilation, even for the smallest wet room. The night time relative humidity setback feature suppresses nuisance tripping as humidity gradually increases with falling temperature.

## Acoustic Solution

For scenarios where noise is a critical issue, The Sentinel Kinetic Acoustic Solution is also available for all Sentinel Kinetic units. An Acoustic Enclosure will reduce breakout noise and the Acoustic Top Box will reduce in-duct noise at key frequencies. The acoustic solution sound data for each product can be found on the relevant product page.



## Filtration

A new ISO filtration standard has come into force. The test method has changed so direct comparisons between EN779 2012 and ISO 16890 cannot be drawn. Below is a guide to the filter efficiencies:

ISO 16890	EN779
45% Coarse	G3
65% Coarse	G4
ePM10 50%	M5
ePM2.5 70%	F7

For sensors see Accessories & Controllers section.

## Sentinel Control

The Sentinel controller is the most advanced system available, providing Demand Control Ventilation (DCV), minimising energy consumption and noise levels, and optimising ventilation performance. Sentinel controlled units may be set to operate fully automatically or with varying levels of manual intervention.

## Building Management System (BMS) Options

There are two levels of BMS available: Basic Output and full Electronic BMS.

Basic Output provides a 5 volt output from the LED terminals on the controller. This output occurs whenever a message appears in the digital display, for example; 'Check Filters' or a fault code. The output can also be converted to volt-free with the addition of an optional Opto-Coupler.

Electronic BMS: A full range of two-way digital signals are available through the RJ11 connector on the control board. The BMS system provider will translate this signal to extract the desired data. Contact Vent-Axia to discuss your specific requirements.

## LED Alarm

MVHR units are often installed in lofts or other locations where they are difficult to monitor. The optional remote LED alarm illuminates when any message is visible in the MVHR unit display panel. The LED alarm can be installed in a convenient location within the dwelling allowing end users to see that the unit requires attention.

## Control Inputs

Five volt-free pairs of switch terminals for sensor inputs allow boosting from a full range of Vent-Axia controllers – humidistats, PIR, timers.

Two terminals with 0-24V outputs allow 0V to 10V proportional control by sophisticated controllers such as CO<sub>2</sub> sensors and proportional humidistats.

Switched-live for boosting via light switches (220-240V AC) or manual Normal/Boost switches. This connection has the advantage of Delay-On and Delay-Off facility. Delay-On enables you to prevent the Boost airflow between 0 and 10 minutes, after a light switch has been activated. Delay-Off allows the Boost airflow to continue after a light switch is turned off to ensure effective clearance of humidity. This timer is adjustable between 0 and 25 minutes.

The units can be boosted incrementally via the on-board controller or the Wired Remote Controller: One press = 30 minutes, two presses = 60 minutes, three presses = continuous.

---

## Frost Protection

In order to prevent frost forming inside the unit in winter conditions, the Kinetic range employs a sophisticated frost protection strategy that modifies the airflows ensuring heat recovery continues down to -20°C. Below this temperature, the units will operate as 'extract only' fans. If balanced ventilation is required at low temperatures, a duct pre-heater should be used.

---

## Optional Controls

Model	Stock Ref
LED Alarm with 15 metre cable	448356
Wired Remote Controller with 15 metre cable	443283

---

## Purge Options

The unit can be set to maximum flow (100%) by pressing and holding the Boost button on the unit itself or optional wired controller for 5 seconds. Purge will continue for two hours unless cancelled by pressing the Boost button again.



In addition, the Acoustic Purge Fan can be used in conjunction with a Sentinel Kinetic MVHR unit or independently via a separate switched live connection or 0-10V external sensor input.

Model	Stock ref
Acoustic Purge Fan	477988
Acoustic Purge Fan XL	479829

---

## Summer Bypass

An internal damper operates when the external temperature is below the internal temperature, and the internal temperature is too high.

The bypass opens and allows the cooler outside air to help cool the dwelling.

Normal mode: Fans run on Normal speed with bypass open until the internal dwelling temperature falls below the set 'Indoor' (maximum desired) temperature.

Evening Purge mode: The fans run on Boost speed until the internal temperature falls below the set 'Indoor' temperature. If, after five hours the internal temperature is still above the set 'Indoor' temperature, the unit will switch down to normal speed for the remainder of the 'bypass open' period.

Nighttime Purge mode: As Evening Purge, except that the unit will continue on Boost speed until the internal air temperature reaches the 'Outdoor' temperature set point (Default 14°C). This mode gives pre-cooling of the dwelling for the following day.

In Evening and Night Time Purge modes, the user can turn off the boost function by pressing the Boost button.

A Summer Bypass can make a contribution to reducing internal temperatures but is not a substitute for appropriate design and construction.

---

## System Cooker Hood Range

System canopy hoods are a motorless hood with extract being provided by the MVHR unit. When the Boost button on the canopy is activated, the MVHR unit goes to boost setting and the summer bypass opens preventing cooking by-products entering the heat exchanger cell. SELV hoods allow the distance between the hood and an electric hob to be reduced from 650mm to 550mm.



Model	Stock ref
White	407509
Aluminium	407206
White SELV	474790
Aluminium SELV	474791

# Sentinel Range Overview



Model Ranges	Lo-Carbon Sentinel Econiq Passivhaus			Lo-Carbon Sentinel Econiq			Lo-Carbon Sentinel Kinetic BH
Models	SCP	MCP	LCP	S	M	L	BH
Spigot Size	125	200	200	125	200	200	125
Dimensions (mm) HxWxD	823x660x443	931x728x608	931x728x608	823x660x443	931x728x608	931x728x608	640x550x285
Max Airflow	97 @ 150	125 @ 150	167 @ 150	97 @ 150	125 @ 150	167 @ 150	68 @ 100Pa
Standard Filters	G4 (extract) & F7 (supply)	G4 (extract) & F7 (supply)	G4 (extract) & F7 (supply)	G4	G4	G4	G3
Constant Volume	✓	✓	✓				
Sentinel-X Compatibility	✓	✓	✓	✓	✓	✓	
Passivhaus Certified	✓	✓	✓				
Internal Pre-Heater	✓	✓	✓				
App Connectivity	✓	✓	✓	✓	✓	✓	
Acoustic Enclosure	○*	○*	○*	○			○
Acoustic Top Box	○*	○*	○*	○			○
Auto Summer Bypass	✓	✓	✓	✓	✓	✓	✓
Easy Access Filters	✓	✓	✓	✓	✓	✓	✓
Integral Cooker Hood							
Built-In Humidistat	✓	✓	✓	✓	✓	✓	✓
Kitchen Cupboard Installation							✓
Frost Protection	✓	✓	✓	✓	✓	✓	✓
Delay-On	✓	✓	✓	✓	✓	✓	✓
Wired Remote Control	○	○	○	○	○	○	○
Wireless Boost	○	○	○	○	○	○	
Clean Filter Indicator (Time)	✓	✓	✓	✓	✓	✓	✓
Fault Code Indicator	✓	✓	✓	✓	✓	✓	✓
Volt Free Contact	✓	✓	✓	✓	✓	✓	✓
0V - 10V Proportional Control	✓	✓	✓	✓	✓	✓	✓
BMS Input/Output	✓	✓	✓	✓	✓	✓	✓ <sup>1</sup>
Lightweight				✓			✓
External Condensate	✓	✓	✓	✓	✓	✓	✓
Horizontal Duct Option	✓**	✓**	✓**		✓	✓	✓
Horizontal (Slab) Installation							
Left/Right Orientation	✓	✓	✓	✓	✓	✓	✓
PIN Number Lock	✓	✓	✓	✓	✓	✓	✓
Running Time Indicator	✓	✓	✓	✓	✓	✓	✓
Enthalpy Heater Exchanger	○	○	○	○	○	○	○
Mounting Options	 Wall Floor			 Wall Floor			 Wall Surface

○ - Denote Optional, 1- Seek technical advice from Vent-Axia.

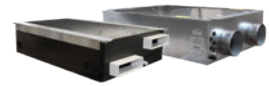

Model Ranges	Lo-Carbon Sentinel Kinetic FH	Lo-Carbon Sentinel Kinetic Plus	Lo-Carbon Sentinel Kinetic High Flow	Lo-Carbon Sentinel Kinetic Cooker Hood SELV	Lo-Carbon Sentinel Kinetic Horizontal		
Models	FH	Plus	High Flow	CH	200ZPH	300ZH	200ZH/ZMH
Spigot Size	125	150	180	125	204x60	150	125/204x60
Dimensions (mm) HxWxD	555x640x350	785x722x550	785x722x550	590x710x316	575x200x1000	720x301x985	570x200x895
Max Airflow	79 @ 100Pa	117 @ 100Pa	185 @ 100Pa	68 @ 100	37 @ 100Pa	81 @ 100Pa	50 @ 100Pa
Standard Filters	G3	G3	G3	G3	G3	G3	G3
Constant Volume							
Sentinel-X Compatibility							
Passivhaus Certified							
Internal Pre-Heater							
App Connectivity							
Acoustic Enclosure	○	○	○				
Acoustic Top Box	○	○	○				
Auto Summer Bypass	✓	✓	✓	✓	✓	✓	✓
Easy Access Filters	✓	✓	✓	✓	✓	✓	✓
Integral Cooker Hood				✓			
Built-In Humidistat	✓	✓	✓	✓			
Kitchen Cupboard Installation				✓			
Frost Protection	✓	✓	✓	✓	✓	✓	✓
Delay-On	✓	✓	✓	✓	✓	✓	✓
Wired Remote Control	○	○	○	○	○	○	○
Wireless Boost							
Clean Filter Indicator (Time)	✓	✓	✓	✓	✓	✓	✓
Fault Code Indicator	✓	✓	✓	✓	✓	✓	✓
Volt Free Contact	✓	✓	✓	✓	✓	✓	✓
0V - 10V Proportional Control	✓	✓	✓	✓	✓	✓	✓
BMS Input/Output	✓1	✓1	✓1	✓1	✓1	✓1	✓1
Lightweight	✓	✓	✓				
External Condensate	✓	✓	✓	✓	✓	✓	✓
Horizontal Duct Option	✓	✓	✓	✓	✓	✓	✓
Horizontal (Slab) Installation					✓	✓	✓
Left/Right Orientation	✓	✓	✓	✓			
PIN Number Lock	✓	✓	✓	✓	✓	✓	✓
Running Time Indicator	✓	✓	✓	✓	✓	✓	✓
Enthalpy Heater Exchanger	○	○	○				
Mounting Options	 Wall Surface		 Wall Surface		 Wall	 Slab	

○ - Denote Optional, 1- Seek technical advice from Vent-Axia.

# Lo-Carbon Sentinel Econiq Passivhaus Certified

- Passivhaus certified
- New Sentinel-X wireless control platform
- Intelligent smart app control as standard
- Horizontal duct option for space-saving installations (M & L only)
- Sound levels as low as 15.5 dB(A) breakout - independently tested and verified by SRL
- Developed and manufactured in the UK
- Constant Volume - Maintains pre-set airflow irrespective of system pressure within it's performance capabilities
- Built-in pre-heater as standard with optional external duct heaters



## Passivhaus

MVHR is a critical part of a Passivhaus project and it's success in driving down energy demand. The performance of the MVHR system is considered an integral element of the primary Passivhaus heating demand calculation.

Vent-Axia's new range of MVHR's can support you with your next Passivhaus project with our most advanced MVHR's and wired or wireless control platform.

Our Passivhaus certified MVHR's provide up to 86% Thermal Efficiency. And free cooling through an Intelligent Summer Bypass during the warmer months

F7 Filters as standard, along with Constant Volume and internal pre-heaters means you will have control over your indoor environment.

---

The Lo-Carbon Sentinel Econiq is Vent-Axia's latest flagship mechanical ventilation with heat recovery system. Designed and developed in the UK, it offers the highest level of comfort and functionality all year round.

Introducing a full range of products, with air performance suitable for all types of homes, the new Sentinel-X wireless controls platform delivers complete control over the home environment, provided through a full range of wired/wireless sensors and a smartphone app.

## A Whole New Experience

The highly sculpted interior surfaces, designed using the latest CFD techniques, ensure airflows are maximised through the unit, minimising noise and energy use. This feature alone provides an experience, that will delight homeowners, providing the most discrete and highly efficient ventilation available.

## Air Quality and Health

The MVHR filter options offer numerous benefits, including improved indoor air quality by removing allergens and particulate matter. They maintain the system's energy efficiency, reduce heating and cooling costs, and enhance the overall longevity of the system. Additionally, they capture bacteria,

viruses and VOCs, promoting a healthier living environment. Regular filter maintenance extends the system's lifespan and ensures uninterrupted operation.

Whatever the outside environment, the system can help improve the indoor air quality by filtering out impurities, with ISO ePM2.5 (F7), which can filter out mould spores, bacteria and particles smaller or equal to 2.5µm supplied as standard on the supply side, we also have ISO 60% Coarse (G4) supplied as standard on extract, which can filter out sand, fine hair and particles larger than 10µm. Additional filtration can be achieved with a selection of optional filters, such as ISO ePM10 (M5), which can filter pollen, stone dust and particles smaller or equal to 10µm.

The various sensor options allow for flexible installation in individual rooms, supporting effective management of the air in the home. For example, a CO<sub>2</sub> sensor located within a habitable room helps ensure a healthy and safe working environment. CO<sub>2</sub> levels managed at less than 1000ppm help promote cognitive function. A humidity sensor located in the bathroom detects high levels of moisture can support good indoor air quality.

## Low Noise Levels

The Lo-Carbon Sentinel Econiq is one of the quietest systems on the market, with a noise level as low as 15.5 dB(A). The range is designed with an integral acoustic enclosure, made of steel, foam and expanded polypropylene (EPP), minimising breakout noise. The highly efficient motors are mounted on anti-vibration mounts to ensure minimal vibration transmission.

## Demand Control Ventilation

The Vent-Axia Connect smartphone application allows a multitude of functions to be adjusted from the comfort of the sofa, available on iOS and Android.

With smartphone compatible controls, the homeowner is in full control of their ventilation all year round. They have the flexibility to increase the ventilation rate during hot periods in the summer or reducing the speed to minimise running costs while away.

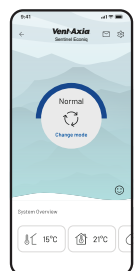

The Sentinel control logic built within the MVHR ensures the system operates optimally with automated functions such as frost protection and summer bypass, providing comfort in the home.



## Integral Humidity Sensor

The integral humidity sensor increases speed in proportion to relative humidity levels, saving energy and reducing noise. The sensor also reacts to small but rapid increases in humidity, even if the normal trigger threshold is not reached. This unique feature ensures adequate ventilation, even for the smallest wet room. The night time relative humidity setback feature suppresses nuisance tripping as humidity gradually increases with falling temperatures.

## Airtight Buildings

Low-energy buildings typically have very low leakage rates (below 3m<sup>3</sup>/(h.m<sup>2</sup>) at 50Pa). This reduces the effectiveness of the standard frost protection strategy which imbalances the airflows. With Passivhaus design very low air leakage rates are required to meet the standard and must be demonstrated for each certified building. The air change rate must be less than or equal to 0.6 air changes per hour at 50pa, under test conditions.

## Spigot Options (MCP & LCP only)

The inclusion of horizontal spigots allows for flexible installation in tight spaces. It is possible to use both vertical and horizontal connections.

## Model

Description	Stock Ref
Sentinel Econiq SCP RH	499890
Sentinel Econiq SCP LH	499891
Sentinel Econiq MCP RH	499639
Sentinel Econiq MCP LH	499640
Sentinel Econiq LCP RH	499648
Sentinel Econiq LCP LH	499649
Sentinel Econiq SCP RH with In-Duct Heater Passivhaus Kit	413664
Sentinel Econiq SCP LH with In-Duct Heater Passivhaus Kit	413665
Sentinel Econiq MCP RH with In-Duct Heater Passivhaus Kit	413666
Sentinel Econiq MCP LH with In-Duct Heater Passivhaus Kit	413667
Sentinel Econiq LCP RH with In-Duct Heater Passivhaus Kit	413668
Sentinel Econiq LCP LH with In-Duct Heater Passivhaus Kit	413669

## Accessories

Description	Stock Ref
In-Duct Heater - Ø125mm /1.25kW	413662
In-Duct Heater - Ø200mm /2.5kW	413663
Wall Mounting Kit for Controller	411628
Econiq S Acoustic Solution Enclosure Kit	414012
Econiq S Acoustic Solution Top Box Kit	414013
Econiq S Acoustic Solution Top Box & Enclosure Kit	414014
Econiq M & L Floor Stand	414122

## Spare Filters

### Sentinel Econiq SCP

Description	Stock Ref
ISO 60% Coarse (G4) Filter 2 per Pack	411689
ISO ePM10 50% (M5) Filter 1 per Pack	472669
ISO ePM2.5 70% (F7) Filter 1 per Pack	472671

### Sentinel Econiq MCP & LCP

Description	Stock Ref
ISO 60% Coarse (G4) Filter 2 per Pack	411690
ISO ePM10 50% (M5) Filter 1 per Pack	411691
ISO ePM2.5 70% (F7) Filter 1 per Pack	411692

## Sensor Overview

Power	Colour	CO <sub>2</sub>	PIR	Temp.	Humidity	Wireless	4 Speed Switch	Stock Ref
Battery	White			✓	✓	✓		496431
Battery	White			✓	✓	✓	✓	496437
Battery	Black			✓	✓	✓	✓	497689
0-10V	White	✓		✓	✓			496432
240V	White			✓	✓	✓		496429
240V	White	✓		✓	✓	✓		496433
240V	White		✓			✓		496438
240V	White			✓	✓	✓	✓	496620
240V	Black			✓	✓	✓	✓	497693
240V	White			✓	✓		✓	496621
240V	Black			✓	✓		✓	497697

## SEC Class

Model	SEC Class
Econiq SCP	A+
Econiq MCP	A+
Econiq LCP	A+

## Passive House Test Results

Model	Airflow range (m <sup>3</sup> /h)	Heat recovery rate (%)	Specific electric power (Wh/m <sup>3</sup> )
Econiq SCP	70-280	85	0.24
Econiq MCP	100-370	86	0.22
Econiq LCP	150-490	86	0.27

## SAP PCDB Test Results

	Econiq SCP		Econiq MCP		Econiq LCP	
	Thermal Efficiency %	SFP (W/l/s)	Thermal Efficiency %	SFP (W/l/s)	Thermal Efficiency %	SFP (W/l/s)
K+1	93	0.39	93	0.41	93	0.56
K+2	92	0.46	93	0.41	93	0.53
K+3	91	0.55	92	0.46	93	0.56
K+4	91	0.70	92	0.55	92	0.62
K+5	90	0.85	91	0.66	91	0.72
K+6	89	1.07	91	0.81	91	0.84
K+7	89	1.31	90	1.00	90	1.01



## Model Range Overview



	Sentinel Econiq SCP	Sentinel Econiq MCP	Sentinel Econiq LCP
Certified Passive House Component ID	2213vs03	2212vs03	2211vs03
Internal Pre-heater	✓	✓	✓
Acoustic Enclosure	○	X	X
Acoustic Top Box	○	X	X
Constant Volume	✓	✓	✓
Recommended max system flow (l/s) @ Pressure (Pa)	97 @ 150	125 @ 150	167 @ 150
Part F Compliant App Commissioning Certificate	✓	✓	✓
RF858 connectivity, 802.11b/g/n Wi-Fi and Bluetooth low energy 4.2	✓	✓	✓
Spigot Options Vertical - Horizontal	Vertical	Vertical & Horizontal	Vertical & Horizontal
Spigot size 125mm or 200mm	125	200	200
Left/Right Hand Orientation Through Control	✓	✓	✓
Fully automatic 100% summer bypass	✓	✓	✓
Active Frost Protection to -20°C	✓	✓	✓
Fault Code Indicator	✓	✓	✓
Easy Access Filters: ISO Coarse 65% (G4) Extract Only	✓	✓	✓
Easy Access Filters: ISO ePM10 50% (M5)	○	○	○
Easy Access Filters: ISO ePM2.5 70% (F7) Supply Only	✓	✓	✓
Clean Filter Indicator (Time frame)	✓	✓	✓
PIN Number Lock	✓	✓	✓
Running Time Indicator	✓	✓	✓
Enthalpy Heat Exchanger	○	○	○
Soft-Start Boost	✓	✓	✓
Delay-On	✓	✓	✓
Number of controllable speeds	4	4	4
Installer function to copy/load unit setup	✓	✓	✓
Inputs 2 x 0-10V; 2 x LS; 5 x Volt-Free	✓	✓	✓
Integral Humidistat	✓	✓	✓
Relay outputs - For example control heaters or geothermal heat exchanger	○	○	○
BMS - modbus supported over RS485	✓	✓	✓
Operating ambient temperature (°C)	-20 to +40	-20 to +40	-20 to +40
Operating Humidity (%RH)	0 to 95	0 to 95	0 to 95
Mounting	Wall or Floor	Wall or Floor	Wall or Floor
Maintenance access	From Front	From Front	From Front

○ - Denote Optional

## Consultant's Specification

### Specification

The Mechanical Ventilation Heat Recovery Unit shall be the Lo-Carbon Sentinel Econiq SCP, MCP or LCP as manufactured by Vent-Axia. It should be sized as indicated on the drawings and shall be in accordance with the particular specification.

The unit shall be fully insulated for thermal and acoustic performance and shall incorporate a high-efficiency composite plastic counter-flow heat exchanger with an independently verified thermal efficiency of up to 93% when tested to EN 308.

The heat exchanger shall be protected by ePM2.5 (F7) on supply and ISO 60% Coarse (G4) grade filters on extract with the facility to accommodate ISO ePM10 (M5), or an inline filter such as the Vent-Axia Pure Air Carbon Filter. The built-in filters shall be accessible via tool-free access doors. The heat exchanger, motors, summer bypass and all other serviceable parts shall be accessible through the front of the unit.

Intake air shall be pre-heated by the internal pre-heater at a trigger temperature of -3°C to protect the heat exchange cell. The Sentinel Econiq shall automatically vary the ventilation rate via EC/DC motors, as it receives signals from optional or in-built sensor inputs. When a signal is received, the fans shall either vary their speed proportionally or on a normal/boost principle. The unit shall have the facility to commission the supply and extract fans individually via in-built minimum and maximum speed adjustment, alternative wired remote-control unit or via a compatible smartphone using the Vent-Axia Connect application. The fans themselves shall have independent, infinitely variable speed control.

The MVHR unit shall be manufactured with an ABS Outer case construction and an Expanded Polystyrene (EPS) inner chassis with custom motor and impeller mounting features. The inner chassis will assist in reducing noise and act as a large anti-vibration mount avoiding transmission through to the back mounting plate or the base of the unit. The MVHR unit shall be tested to ensure it meets the maximum allowable vibration of no more than 1 mm/s, measured on the unit wall fixing points.

The unit shall have a fully automatic 100% summer bypass, integral minimum and maximum infinitely variable speed controls with fascia mounted failure indication. The unit shall have low-energy, high-efficiency EC/DC fan/motor assemblies with sealed for life bearings. The impellers shall be high-efficiency backward curved centrifugal type, achieving an SFP as low as 0.38W/l/s (EN 308).

The unit shall have two condensate drain outlets for handing to be defined onsite and during commissioning. The unit shall have wireless control capability options, using RF868 connectivity, 802.11b/g/n Wi-Fi and Bluetooth low energy 4.2. The unit shall use RF868 to connect to a wide ecosystem of wireless sensors including but not limited to CO<sub>2</sub>, temperature, and relative humidity. The unit shall be able to engage Wi-Fi to connect to local devices and create a local area network to allow for a larger network to be created for commissioning. The unit shall have Bluetooth low energy 4.2 to allow connectivity onto compatible smartphone devices. The unit shall be constructed with a removable tool-free front panel which gives access to the removable on-board controller and other accessories. The EPS panel can then be removed with 4 screws allowing full maintenance access. This shall provide access to the following:

- ✓ Supply or extract fan
- ✓ Heat exchanger
- ✓ Access to the electrical connections

Access shall be provided for wiring termination and setup/commissioning. The unit can be supplied with either a backlit user interface or a blank plate, both of which shall be removable for remote mounting if required. Filters shall be accessed via the two filter drawers found near the top of the unit, the S shall have filter drawers and the M and L shall have filter caps.

Units shall be manufactured by Vent-Axia Ltd.

---

### Standard Controls

The Lo-Carbon Sentinel Econiq shall incorporate the following functions through a user interface fitted by the manufacturer or a paired smartphone with the Vent-Axia Connect application: -

- ✓ Integral infinitely variable fan speed control on supply and extract.
- ✓ 6 speeds; 4 adjustable
- ✓ Left or Right hand spigot configuration, programmable during commissioning
- ✓ Tool free filter access
- ✓ Integral BMS interfaces - control and status indication
- ✓ Heating interlocks
- ✓ 24V external sensor supply, e.g. PIR sensor
- ✓ 0-10V proportional speed adjustment
- ✓ Volt free contacts
- ✓ Fully automatic summer bypass
- ✓ Filter check facility
- ✓ Control panel PIN number lock

The unit shall incorporate:

- ✓ An integral humidity sensor with the following features:
  - Ambient Response; Raises the humidity trigger point as dwelling temperature reduces.
- ✓ Rapid Response: Monitors the rate of change in humidity and triggers increased airflow even if the humidity trigger threshold is not reached.
- ✓ Proportional Response; incrementally increases the fan speed to reduce noise and reduce energy consumption.
- ✓ RS485 connectivity - Long distance cabling to support multiple sensor connections.
- ✓ RF868 connectivity - Radio reference 868 MHz for multiple wireless sensors pairing Bluetooth low energy 4.2 - Enable pairing within compatible smartphone device
- ✓ 802.11b/g/n Wi-Fi - Enable localised access point or connect to the local area network using the Vent-Axia Connect application, via a compatible smartphone device
- ✓ The unit shall incorporate an automatic 100% summer bypass damper which monitors internal and external temperatures to maintain the user comfort temperature (default 25°C):
  - 'Evening Fresh' turns the unit to maximum speed with the bypass operational for 2 hours or until the user comfort temperature is reached (default 25°C).
  - 'Night Time Fresh' will run the unit at maximum speed with the bypass operational throughout the night or until the dwelling reaches minimum temperature (default 14°C).

Independently acoustically tested to BS EN 13141-7:2010

---

# Sentinel Econiq SCP

## Dimensions (mm)

Unit

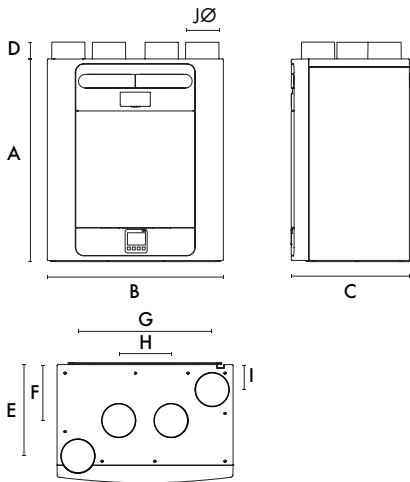

A	B	C	D	E	F	G	H	I	JØ	kg
760	660	443	63	343	210	503	197	93	125	27

Packed weight: 32kg

## Sound Spectrum (Unit only)

Speed	Test mode	Octave Band (Hz) Sound Power Levels, dB								LwA	SPL dB(A) @ 3m
		63	125	250	500	1k	2k	4k	8k		
20%	Supply	52.9	50.9	46.8	43.0	34.6	27.1	19.2	25.4	43.9	26.4
	Extract	50.3	49.0	36.0	31.5	23.6	16.1	18.9	25.3	36.4	18.9
	Breakout	34.6	34.8	35.7	34.9	29.6	25.1	21.0	25.3	36.0	15.5
40%	Supply	59.5	56.5	59.4	55.0	48.2	42.6	31.8	26.1	55.9	38.4
	Extract	51.9	51.3	50.4	41.2	35.0	25.3	19.8	25.4	44.8	27.3
	Breakout	40.2	42.6	46.5	45.4	41.0	36.2	25.5	25.3	46.5	26.0
60%	Supply	66.9	62.4	63.3	62.0	57.9	53.5	43.4	34.2	63.2	45.7
	Extract	60.6	60.3	54.2	49.5	44.4	36.2	27.9	26.3	51.7	34.2
	Breakout	45.5	49.8	52.5	53.1	49.7	46.7	36.2	26.9	54.5	34.0
80%	Supply	82.4	67.6	65.2	67.6	64.2	60.8	50.8	43.2	69.2	51.7
	Extract	75.5	68.6	59.3	56.0	48.3	44.2	36.9	31.3	58.6	41.1
	Breakout	59.2	55.0	56.8	60.0	55.4	53.9	44.1	33.4	61.0	40.5
100%	Supply	79.4	69.6	66.6	75.1	64.9	63.6	53.4	45.7	73.7	56.2
	Extract	72.4	70.5	60.5	56.4	49.8	46.3	39.0	33.4	59.5	42.0
	Breakout	63.0	57.1	58.5	63.7	56.8	55.9	46.4	36.2	63.5	43.0

Tested according to BS EN 13141-7:2010. Breakout quoted spherical. Supply and Extract quoted hemispherical. For in-duct data, end reflections are added based on the spigot size of the unit.

## Performance (Sentinel Econiq SCP)

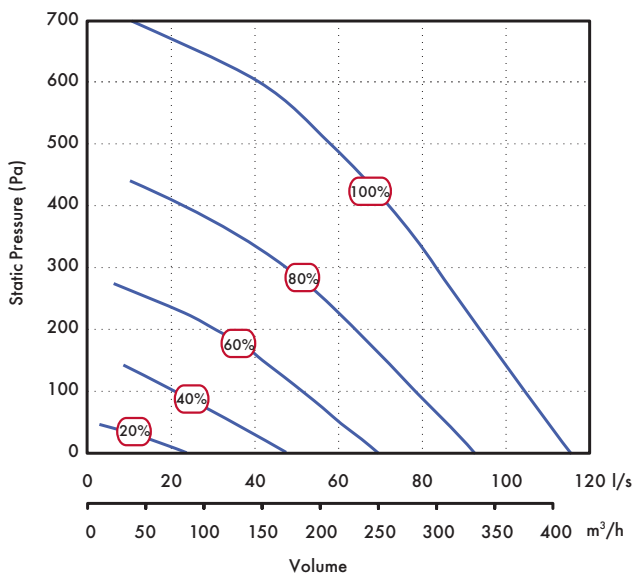

## Acoustic Solution

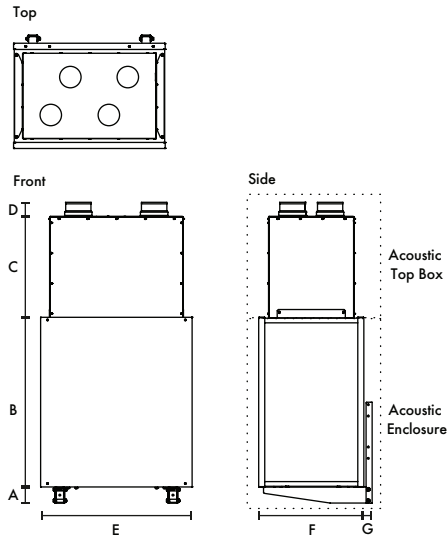

Acoustic Top Box		Acoustic Enclosure		kg	kg	Spigot			
A	B	C	D						
80	840	501	68	750	520	40	14	27	125

## Sound Spectrum (Solution Top Box & Enclosure Kit)

Speed	Test mode	Octave Band (Hz) Sound Power Levels, dB								LwA	SPL dB(A) @ 3m
		63	125	250	500	1k	2k	4k	8k		
20%	Supply	54.7	50.5	41.5	30.8	18.6	14.7	18.2	24.0	38.0	20.5
	Extract	54.8	41.7	31.4	20.2	15.2	13.8	18.3	24.3	31.9	14.4
	Breakout	36.6	47.3	38.0	24.7	19.3	16.6	19.1	23.6	34.0	13.5
40%	Supply	61.0	57.7	56.0	39.0	27.5	16.6	18.4	24.1	48.9	31.4
	Extract	55.7	50.8	44.6	26.8	19.1	15.0	18.2	24.0	39.2	21.7
	Breakout	55.9	55.2	48.2	35.5	29.9	20.9	20.4	25.3	42.6	22.1
60%	Supply	64.5	64.3	56.2	48.6	36.0	22.8	19.0	24.2	52.3	34.8
	Extract	59.4	57.3	46.6	36.0	25.6	17.4	18.6	24.5	43.9	26.4
	Breakout	43.5	60.5	49.5	43.5	39.0	32.0	23.8	23.7	47.6	27.1
80%	Supply	68.9	65.9	59.9	53.9	41.4	29.3	21.6	24.7	55.9	38.4
	Extract	63.1	69.3	52.6	43.0	33.4	23.7	20.2	24.6	54.5	37.0
	Breakout	48.3	69.8	52.7	48.3	44.7	39.8	33.2	25.9	57.1	36.6
100%	Supply	72.5	70.5	63.1	56.1	43.9	33.0	23.7	25.2	59.3	41.8
	Extract	70.3	61.9	56.2	45.4	36.6	28.0	22.9	24.6	51.5	34.0
	Breakout	54.3	67.1	63.3	51.3	47.9	43.9	38.5	28.7	57.7	37.2

## Spigot Configuration (Sentinel Econiq SCP)

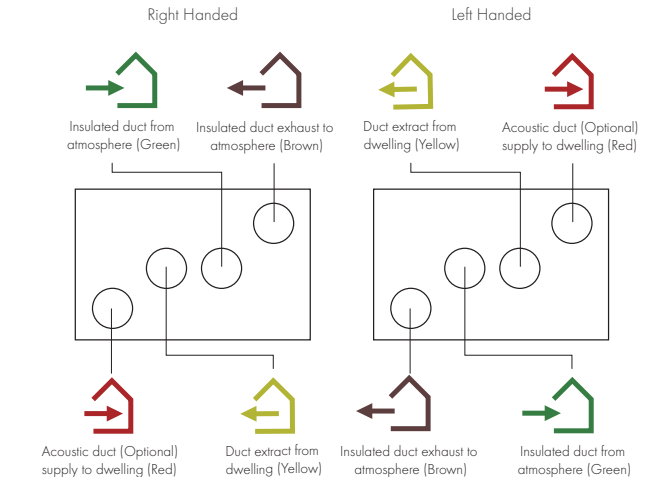

Hand-able through controller (except if pre-heater fitted)

# Sentinel Econiq MCP & LCP

## Dimensions (mm) (Sentinel Econiq MCP & LCP)

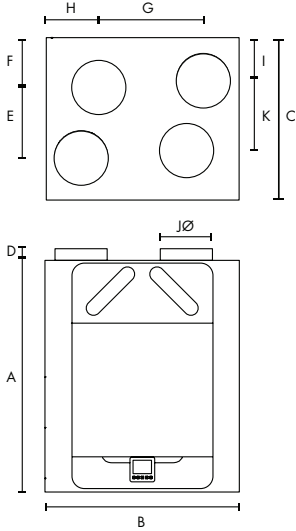

A	B	C	D	E	F	G	H	I	Jø	K	kg
881	728	608	50	261	187	394	200	160	200	261	50

Packed weight: 55kg

## Spigot Configuration (Sentinel Econiq MCP & LCP)

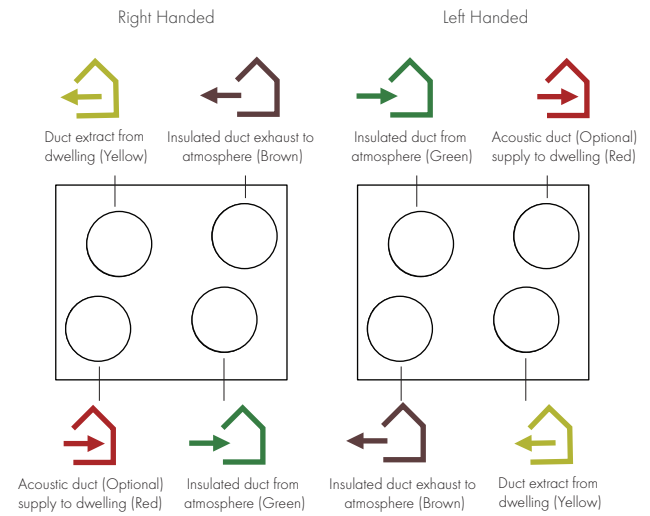

For Passivhaus units handling must be chosen at the point of order as this is managed in production.

## Sound Spectrum (Sentinel Econiq MCP)

Speed	Test mode	Octave Band (Hz) Sound Power Levels, dB								SPL dB(A) @ 3m
		63	125	250	500	1k	2k	4k	8k	
20%	Breakout	32	41	35	31	24	17	19	23	12
	Inlet	48	42	33	23	19	14	17	22	13
	Outlet	55	55	48	41	34	23	18	22	27
40%	Breakout	36	45	46	42	36	25	19	23	22
	Inlet	54	45	43	33	31	20	18	22	21
	Outlet	64	58	57	52	49	40	26	22	37
60%	Breakout	43	50	51	48	44	36	22	23	29
	Inlet	59	51	51	39	39	29	20	22	28
	Outlet	69	64	65	58	58	51	38	26	45
80%	Breakout	48	55	56	53	50	43	30	24	34
	Inlet	65	56	57	46	44	37	26	22	34
	Outlet	73	68	67	64	63	59	47	35	50
100%	Breakout	60	60	57	58	55	47	36	29	38
	Inlet	69	59	54	48	48	41	31	24	35
	Outlet	76	70	67	69	66	63	53	42	53

## Sound Spectrum (Sentinel Econiq LCP)

Speed	Test mode	Octave Band (Hz) Sound Power Levels, dB								SPL dB(A) @ 3m
		63	125	250	500	1k	2k	4k	8k	
20%	Breakout	41	41	51	47	40	18	19	23	26
	Inlet	50	43	42	38	31	16	18	23	21
	Outlet	57	56	53	47	40	29	19	24	31
40%	Breakout	41	44	53	52	43	32	20	23	31
	Inlet	60	48	50	38	37	26	19	23	27
	Outlet	68	62	62	56	55	49	33	24	42
60%	Breakout	44	50	55	56	48	42	27	23	34
	Inlet	63	54	59	44	43	37	24	23	35
	Outlet	71	67	67	62	62	59	46	34	49
80%	Breakout	55	54	54	60	52	47	36	24	38
	Inlet	69	60	55	50	48	43	33	24	36
	Outlet	78	72	66	70	67	65	56	44	54
100%	Breakout	67	67	58	72	58	50	42	27	50
	Inlet	81	64	58	57	51	47	39	27	42
	Outlet	91	76	69	74	70	69	62	50	58

## Performance (Sentinel Econiq MCP)

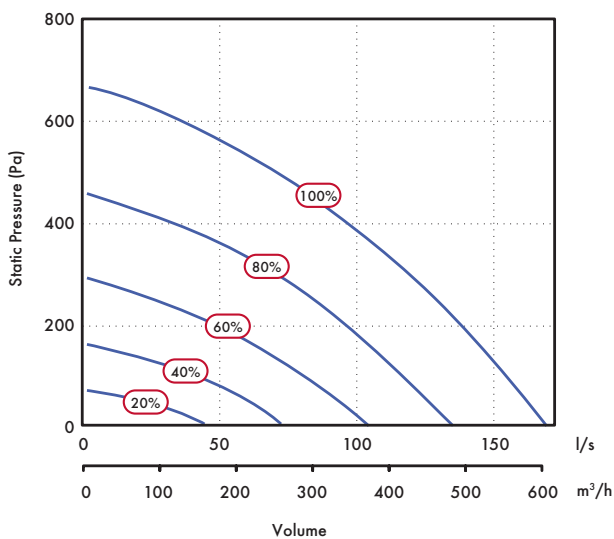

## Performance (Sentinel Econiq LCP)

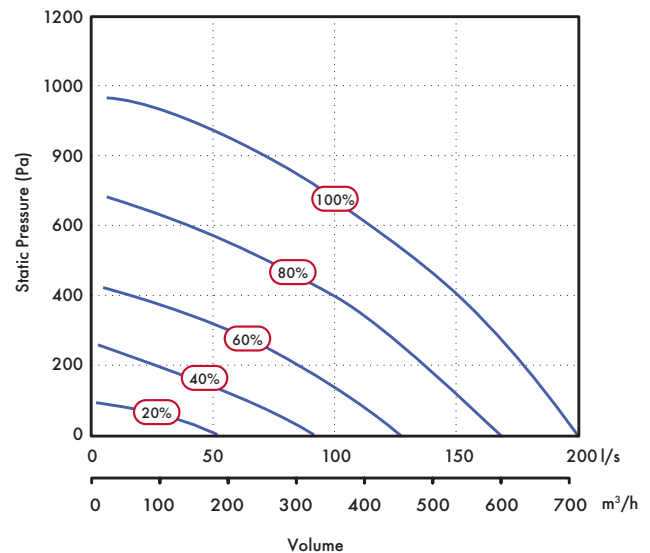

# Sentinel-X Controllers

## Battery Controllers & Sensors



### Battery - Internal Temperature and Humidity - Wireless

Room mounted humidity and temperature sensor for wired or wireless communication with a compatible system. Using an in-built RF 868 MHz (Wireless radio frequency), or RS485 (Wired connection) communication method whilst being powered by batteries.

- Dimensions (HxWxD) (mm) 60 x 60 x 22
- 2 x AAA Batteries included
- Temperature range 0~60°C
- Relative humidity range 0-90% RH
- Wireless range 20m closed/100m open
- RF 868MHz Wireless or RS485 Wired communication
- Status LED indicator for pairing, health check and fault conditions
- Mounted using provided back plate

Stock Ref

496431



### Battery - 4 Speed Switch with Temperature and Humidity - Wireless

Room mounted Speed Switch for wireless communication with a compatible system. Using an in-built RF 868 MHz (Wireless radio frequency) communication whilst being powered by batteries.

- Dimensions (HxWxD) (mm) 90 x 90 x 17
- 2 x AAA Batteries included
- Temperature range 0~60°C
- Relative humidity range 0-90% RH
- Wireless range 20m closed/100m open
- RF 868MHz Wireless
- Mounted using provided back plate or compatible with a standard single gang or surface mounted pattress box
- Status LED indicator for pairing, health check and fault conditions

Model

Stock Ref

White

496437

Black

497689

## HMI Kit



### Wall-mounted HMI Kit to suit Econiq models with full HMI

Includes HMI Blank controller, HMI backplate and cable.

- Dimensions (HxWxD) (mm) 90 x 90 x 17
- Power supply 240V
- Wireless range 20m closed/100m open
- RF 868MHz Wireless or RS485 Wired communication
- Compatible with standard single gang or surface mounted pattress box

Stock Ref

411628

## 24V Sensor



### 0-10V CO<sub>2</sub>, Temperature and Humidity - Wired

Room mounted CO<sub>2</sub> sensor with 0-10V signal output powered by an external 24V supply.

- Dimensions (HxWxD) (mm) 90 x 90 x 17
- 24V Power supply required
- Temperature range 0~60°C
- Relative humidity range 0-90% RH
- CO<sub>2</sub> range 0-2000PPM
- Compatible with standard single gang or surface mounted pattress box
- Status LED indicator for pairing, health check, faults & air quality traffic light index
- 0-10V Wired Communication

Stock Ref

496432

# Sentinel-X Controllers

## 240V Controllers & Sensors



### 240V - Internal Temperature and Humidity - Wireless

Room mounted humidity and temperature sensor for wired or wireless communication with a compatible system. Using an in-built RF 868 MHz (Wireless radio frequency), or RS485 (Wired connection) communication method whilst being powered by a local 240V supply.

- Dimensions (HxWxD) (mm) 90 x 90 x 17
- Power supply 240V
- Temperature range 0~60°C
- Relative humidity range 0-90% RH
- Wireless range 20m closed/100m open
- RF 868MHz Wireless or RS485 Wired communication
- Compatible with standard single gang or surface mounted pattress box
- Status LED indicator for pairing, health check, faults & air quality traffic light index

Stock Ref  
**496429**



### 240V - CO<sub>2</sub>, Temperature and Humidity - Wireless

Room mounted CO<sub>2</sub> sensor for wired or wireless communication with a compatible system. Using an in-built RF 868 MHz (Wireless radio frequency), or RS485 (Wired connection) communication method whilst being powered by a local 240V supply.

- Dimensions (HxWxD) (mm) 90 x 90 x 17
- Power supply 240V
- Temperature range 0~60°C
- Relative humidity range 0-90% RH
- CO<sub>2</sub> Range 0-2000 PPM
- Wireless range 20m closed/100m open
- RF 868MHz Wireless or RS485 Wired communication
- Compatible with standard single gang or surface mounted pattress box
- Status LED indicator for pairing, health check, faults & air quality traffic light index

Stock Ref  
**496433**



### 240V - 4 Speed Switch with Temperature and Humidity - Wired

Room mounted Speed Switch for wired communication with a compatible system. Using an in-built RS485 communication method powered by a local 240V supply.

- Dimensions (HxWxD) (mm) 90 x 90 x 17
- Power Supply 240V
- Temperature range 0~60°C
- Relative humidity range 0-90% RH
- Mounted using provided back plate or compatible with standard single gang or surface mounted pattress box
- Status LED indicator for pairing, health check and fault conditions
- RS485 Wired Connection

Model  
White  
Black

Stock Ref  
**496621**  
**497697**



### 240V - 4 Speed Switch with Temperature and Humidity - Wireless

Room mounted Speed Switch for wireless communication with a compatible system. Using an in-built RF 868 MHz (Wireless radio frequency) communication method whilst being powered by a local 240V supply.

- Dimensions (HxWxD) (mm) 90 x 90 x 17
- Power Supply 240V
- Temperature range 0~60°C
- Relative humidity range 0-90% RH
- Wireless range 20m closed/100m open
- RF 868MHz Wireless
- Mounted using provided back plate or compatible with standard single gang or surface mounted pattress box
- Status LED indicator for pairing, health check and fault conditions

Model  
White  
Black

Stock Ref  
**496620**  
**497693**



### 240V - PIR Sensor - Wireless

Room mounted PIR sensor for wired or wireless communication with a compatible system. Using an in-built RF 868 MHz (Wireless radio frequency), or RS485 (Wired connection) communication method whilst being powered by a local 240V supply. Room mounted presence detector for min/max or on/off control. Wall or ceiling mounting.

- Dimensions (HxWxD) (mm) 90 x 90 x 17
- Power supply 240V
- 5-25min run on timer
- PIR Range 3m
- Compatible with standard single gang or surface mounted pattress box
- Wireless range 20m closed/100m open
- RF 868MHz Wireless or RS485 Wired communication

Stock Ref  
**496438**



# Lo-Carbon Sentinel Econiq

- Best in class SFP's and thermal efficiencies up to 93%
- Approved Document F aligned commissioning wizard
- New Sentinel-X wireless control platform
- Intelligent smart app control as standard
- Horizontal duct option for space-saving installations (M & L only)
- ISO ePM10 (M5) and ePM2.5 (F7) filtration options
- Sound levels as low as 15.5 dB(A) breakout - independently tested and verified by SRL
- Left/right handing via controls
- Developed and manufactured in the UK
- Acoustic enclosure and top box options (S only)



The Lo-Carbon Sentinel Econiq is Vent-Axia's latest flagship mechanical ventilation with heat recovery system. Designed and developed in the UK, it offers the highest level of comfort and functionality all year round.

Introducing a full range of products, with air performance suitable for all types of homes, the new Sentinel-X wireless controls platform delivers complete control over the home environment, provided through a full range of wired/wireless sensors and a smartphone app.

## A Whole New Experience

The highly sculpted interior surfaces, designed using the latest CFD techniques, ensure airflows are maximised through the unit, minimising noise and energy use. This feature alone provides an experience, that will delight homeowners, providing the most discrete and highly efficient ventilation available.

## Air Quality and Health

The MVHR filter options offer numerous benefits, including improved indoor air quality by removing allergens and particulate matter. They maintain the system's energy efficiency, reduce heating and cooling costs, and enhance the overall longevity of the system. Additionally, they capture bacteria, viruses and VOCs, promoting a healthier living environment. Regular filter maintenance extends the system's lifespan and ensures uninterrupted operation.

Whatever the outside environment, the system can help improve the indoor air quality by filtering out impurities, with ISO 60% Coarse (G4) supplied as standard, which can filter out sand, fine hair and particles larger than 10µm. Additional filtration can be achieved with a selection of optional filters, such as ISO ePM10 (M5), which can filter pollen, stone dust and particles smaller or equal to 10µm and ISO ePM2.5 (F7), which can filter out mould spores, bacteria and particles smaller or equal to 2.5µm.

The various sensor options allow for flexible installation in individual rooms, supporting effective management of the air in the home. For example, a CO<sub>2</sub> sensor located within a habitable room helps ensure a healthy and safe working environment. CO<sub>2</sub> levels managed at less than 1000ppm

help promote cognitive function. A humidity sensor located in the bathroom detects high levels of moisture can support good indoor air quality.

## Low Noise Levels

The Lo-Carbon Sentinel Econiq is one of the quietest systems on the market, with a noise level as low as 15.5 dB(A). The range is designed with an integral acoustic enclosure, made of steel, foam and expanded polypropylene (EPP), minimising breakout noise. The highly efficient motors are mounted on anti-vibration mounts to ensure minimal vibration transmission.

## Demand Control Ventilation

The Vent-Axia Connect smartphone application allows a multitude of functions to be adjusted from the comfort of the sofa, available on iOS and Android.

With smartphone-compatible controls, the homeowner is in full control of their ventilation all year round. They have the flexibility to increase the ventilation rate during hot periods in the summer or reducing the speed to minimise running costs while away.

The Sentinel control logic built within the MVHR ensures the system operates optimally with automated functions such as frost protection and summer bypass, providing comfort in the home.



## Integral Humidity Sensor

The integral humidity sensor increases speed in proportion to relative humidity levels, saving energy and reducing noise. The sensor also reacts to small but rapid increases in humidity, even if the normal trigger threshold is not reached. This unique feature ensures adequate ventilation, even for the smallest wet room. The nighttime relative humidity setback feature suppresses nuisance tripping as humidity gradually increases with falling temperatures.

## Airtight Buildings

Low-energy buildings typically have very low leakage rates (below 3m<sup>3</sup>/(h.m<sup>2</sup>) at 50Pa). This reduces the effectiveness of the standard frost protection strategy which imbalances the airflows.

## Spigot Options (M & L only)

The inclusion of horizontal spigots allows for flexible installation in tight spaces. It is possible to use both vertical and horizontal connections.

## Model

Description	Stock Ref
Sentinel Econiq S	499883
Sentinel Econiq M	499632
Sentinel Econiq L	499641

## Accessories

Description	Stock Ref
Acoustic Purge Fan	477988
Acoustic Purge Fan XL	479829
Wall Mounting Kit for Controller	411628
Econiq S Acoustic Solution Enclosure Kit	414012
Econiq S Acoustic Solution Top Box Kit	414013
Econiq S Acoustic Solution Top Box & Enclosure Kit	414014
Econiq M & L Floor Stand	414122

## Sensor Overview

Power	Colour	CO <sub>2</sub>	PIR	Temp.	Humidity	Wireless	4 Speed Switch	Stock Ref
Battery	White			✓	✓	✓		496431
Battery	White			✓	✓	✓	✓	496437
Battery	Black			✓	✓	✓	✓	497689
0-10V	White	✓		✓	✓			496432
240V	White			✓	✓	✓		496429
240V	White	✓		✓	✓	✓		496433
240V	White		✓			✓		496438
240V	White			✓	✓	✓	✓	496620
240V	Black			✓	✓	✓	✓	497693
240V	White			✓	✓		✓	496621
240V	Black			✓	✓		✓	497697

## Spare Filters

### Sentinel Econiq S

Description	Stock Ref
ISO 60% Coarse (G4) Filter 2 per Pack	411689
ISO ePM10 50% (M5) Filter 1 per Pack	472669
ISO ePM2.5 70% (F7) Filter 1 per Pack	472671

### Sentinel Econiq M & L

Description	Stock Ref
ISO 60% Coarse (G4) Filter 2 per Pack	411690
ISO ePM10 50% (M5) Filter 1 per Pack	411691
ISO ePM2.5 70% (F7) Filter 1 per Pack	411692

## SEC Class

Model	SEC Class
Econiq S	A+
Econiq M	A+
Econiq L	A+

## SAP PCDB Test Results

### Econiq S

	Thermal Efficiency %	SFP (W/l/s)
K+1	93	0.39
K+2	92	0.46
K+3	91	0.55
K+4	91	0.70
K+5	90	0.85
K+6	89	1.07
K+7	89	1.31

### Econiq M

	Thermal Efficiency %	SFP (W/l/s)
K+1	93	0.41
K+2	93	0.41
K+3	92	0.46
K+4	92	0.55
K+5	91	0.66
K+6	91	0.81
K+7	90	1.00

### Econiq L

	Thermal Efficiency %	SFP (W/l/s)
K+1	93	0.56
K+2	93	0.53
K+3	93	0.56
K+4	92	0.62
K+5	91	0.72
K+6	91	0.84
K+7	90	1.01

## Model Range Overview



Sentinel Econiq S

Sentinel Econiq M

Sentinel Econiq L

Recommended max system flow (l/s) @ Pressure (Pa)	97 @ 150	125 @ 150	167 @ 150
Acoustic Enclosure	○	X	X
Acoustic Top Box	○	X	X
Part F Compliant App Commissioning Certificate	✓	✓	✓
RF858 connectivity, 802.11b/g/n Wi-Fi and Bluetooth low energy 4.2	✓	✓	✓
Spigot Options Vertical - Horizontal	Vertical	Vertical & Horizontal	Vertical & Horizontal
Spigot size 125mm or 200mm	125	200	200
Left/Right Hand Orientation Through Control	✓	✓	✓
Fully automatic 100% summer bypass	✓	✓	✓
Active Frost Protection to -20°C	✓	✓	✓
Fault Code Indicator	✓	✓	✓
Easy Access Filters: ISO Coarse 65% (G4)	✓	✓	✓
Easy Access Filters: ISO ePM10 50% (M5)	○	○	○
Easy Access Filters: ISO ePM2.5 70% (F7)	○	○	○
Clean Filter Indicator (Time frame)	✓	✓	✓
PIN Number Lock	✓	✓	✓
Running Time Indicator	✓	✓	✓
Enthalpy Heat Exchanger	○	○	○
Soft-Start Boost	✓	✓	✓
Delay-On	✓	✓	✓
Number of controllable speeds	4	4	4
Installer function to copy/load unit setup	✓	✓	✓
Inputs 2 x 0-10V; 2 x LS; 5 x Volt-Free	✓	✓	✓
Integral Humidistat	✓	✓	✓
Relay outputs - For example control heaters or geothermal heat exchanger	○	○	○
BMS - modbus supported over RS485	✓	✓	✓
Operating ambient temperature (°C)	-20 to +40	-20 to +40	-20 to +40
Operating Humidity (%RH)	0 to 95	0 to 95	0 to 95
Mounting	Wall or Floor	Wall or Floor	Wall or Floor
Maintenance access	From Front	From Front	From Front

○ - Denote Optional

## Consultant's Specification

### Specification

The Mechanical Ventilation Heat Recovery Unit shall be the Lo-Carbon Sentinel Econiq S, M or L as manufactured by Vent-Axia. It should be sized as indicated on the drawings and shall be in accordance with the particular specification.

The unit shall be fully insulated for thermal and acoustic performance and shall incorporate a high-efficiency composite plastic counter-flow heat exchanger with an independently verified thermal efficiency of up to 93% when tested to EN 308.

The heat exchanger shall be protected by ISO 60% Coarse (G4) grade filters on extract and supply with the facility to accommodate ePM2.5 (F7) and ISO ePM10 (M5), or an inline filter such as the Vent-Axia Pure Air Carbon Filter. The built-in filters shall be accessible via tool-free access doors. The heat exchanger, motors, summer bypass and all other serviceable parts shall be accessible through the front of the unit.

The Sentinel Econiq shall automatically vary the ventilation rate via EC/DC motors, as it receives signals from optional or in-built sensor inputs. When a signal is received, the fans shall either vary their speed proportionally or on a normal/boost principle. The unit shall have the facility to commission the supply and extract fans individually via in-built minimum and maximum speed adjustment, alternative wired remote-control unit or via a compatible smartphone using the Vent-Axia Connect application. The fans themselves shall have independent, infinitely variable speed control.

The MVHR unit shall be manufactured with an ABS Outer case construction and an Expanded Polystyrene (EPS) inner chassis with custom motor and impeller mounting features. The inner chassis will assist in reducing noise and act as a large anti-vibration mount avoiding transmission through to the back mounting plate or the base of the unit. The MVHR unit shall be tested to ensure it meets the maximum allowable vibration of no more than 1mm/s, measured on the unit wall fixing points. The unit shall have a fully automatic 100% summer bypass, integral minimum and maximum infinitely variable speed controls with fascia mounted failure indication. The unit shall have low-energy, high efficiency EC/DC fan/motor assemblies with sealed for life bearings. The impellers shall be high-efficiency backward curved centrifugal type, achieving an SFP as low as 0.38W/l/s (EN 308).

The unit shall have two condensate drain outlets for handing to be defined onsite and during commissioning. The unit shall have wireless control capability options, using RF868 connectivity, 802.11b/g/n Wi-Fi and Bluetooth low energy 4.2. The unit shall use RF868 to connect to a wide ecosystem of wireless sensors including but not limited to CO<sub>2</sub>, temperature, and relative humidity. The unit shall be able to engage Wi-Fi to connect to local devices and create a local area network to allow for a larger network to be created for commissioning. The unit shall have Bluetooth low energy 4.2 to allow connectivity onto compatible smartphone devices. The unit shall be constructed with a removable tool free front panel which gives access to the removable on-board controller and other accessories. The EPS panel can then be removed with 4 screws allowing full maintenance access. This shall provide access to the following:

- ✓ Supply or extract fan
- ✓ Heat exchanger
- ✓ Access to the electrical connections

Access shall be provided for wiring termination and setup/commissioning. The unit can be supplied with either a backlit user interface or a blank plate, both of which shall be removable for remote mounting if required. Filters shall be accessed via the two filter drawers found near the top of the unit, the S shall have filter drawers and the M and L shall have filter caps.

Units shall be manufactured by Vent-Axia Ltd.

---

### Standard Controls

The Lo-Carbon Sentinel Econiq shall incorporate the following functions through a user interface fitted by the manufacturer or a paired smartphone with the Vent-Axia Connect application:

- ✓ Integral infinitely variable fan speed control on supply and extract.
- ✓ 6 speeds; 4 adjustable
- ✓ Left or Right hand spigot configuration, programmable during commissioning
- ✓ Tool free filter access
- ✓ Integral BMS interfaces – control and status indication
- ✓ Heating interlocks
- ✓ 24V external sensor supply, eg PIR sensor
- ✓ 0-10V proportional speed adjustment
- ✓ Volt free contacts
- ✓ Fully automatic summer bypass
- ✓ Filter check facility
- ✓ Control panel PIN number lock

The unit shall incorporate:

- ✓ An integral humidity sensor with the following features: Ambient Response; Raises the humidity trigger point as dwelling temperature reduces.
- ✓ Rapid Response: Monitors the rate of change in humidity and triggers increased airflow even if the humidity trigger threshold is not reached.
- ✓ Proportional Response; incrementally increases the fan speed to reduce noise and reduce energy consumption.
- ✓ RS485 connectivity – Long distance cabling to support multiple sensor connections.
- ✓ RF868 connectivity – Radio reference 868 MHZ for multiple wireless sensors pairing Bluetooth low energy 4.2 – Enable pairing within compatible smartphone device
- ✓ 802.11b/g/n Wi-Fi – Enable localised access point or connect to the local area network using the Vent-Axia Connect application, via a compatible smartphone device
- ✓ The unit shall incorporate an automatic 100% summer bypass damper which monitors internal and external temperatures to maintain the user comfort temperature (default 25°C): -
  - 'Evening Fresh' turns the unit to maximum speed with the bypass operational for 2 hours or until the user comfort temperature is reached (default 25°C).
  - 'Night Time Fresh' will run the unit at maximum speed with the bypass operational throughout the night or until the dwelling reaches minimum temperature (default 14°C).

Independently acoustically tested to BS EN 13141-7:2010

---

# Sentinel Econiq S

## Dimensions (mm)

Unit

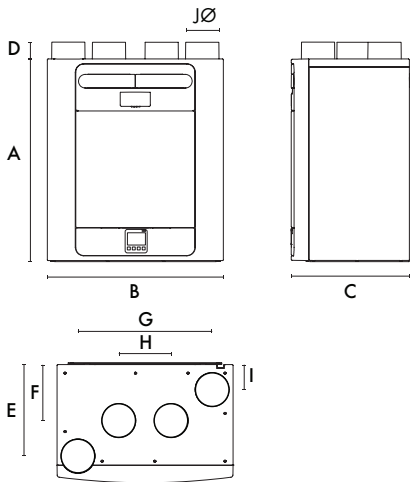

A	B	C	D	E	F	G	H	I	JØ	kg
760	660	443	63	343	210	503	197	93	125	27

Packed weight: 32kg

## Sound Spectrum (Unit only)

Speed	Test mode	Octave Band (Hz) Sound Power Levels, dB								LwA	SPL dB(A) @ 3m
		63	125	250	500	1k	2k	4k	8k		
20%	Supply	52.9	50.9	46.8	43.0	34.6	27.1	19.2	25.4	43.9	26.4
	Extract	50.3	49.0	36.0	31.5	23.6	16.1	18.9	25.3	36.4	18.9
	Breakout	34.6	34.8	35.7	34.9	29.6	25.1	21.0	25.3	36.0	15.5
40%	Supply	59.5	56.5	59.4	55.0	48.2	42.6	31.8	26.1	55.9	38.4
	Extract	51.9	51.3	50.4	41.2	35.0	25.3	19.8	25.4	44.8	27.3
	Breakout	40.2	42.6	46.5	45.4	41.0	36.2	25.5	25.3	46.5	26.0
60%	Supply	66.9	62.4	63.3	62.0	57.9	53.5	43.4	34.2	63.2	45.7
	Extract	60.6	60.3	54.2	49.5	44.4	36.2	27.9	26.3	51.7	34.2
	Breakout	45.5	49.8	52.5	53.1	49.7	46.7	36.2	26.9	54.5	34.0
80%	Supply	82.4	67.6	65.2	67.6	64.2	60.8	50.8	43.2	69.2	51.7
	Extract	75.5	68.6	59.3	56.0	48.3	44.2	36.9	31.3	58.6	41.1
	Breakout	59.2	55.0	56.8	60.0	55.4	53.9	44.1	33.4	61.0	40.5
100%	Supply	79.4	69.6	66.6	75.1	64.9	63.6	53.4	45.7	73.7	56.2
	Extract	72.4	70.5	60.5	56.4	49.8	46.3	39.0	33.4	59.5	42.0
	Breakout	63.0	57.1	58.5	63.7	56.8	55.9	46.4	36.2	63.5	43.0

Tested according to BS EN 13141-7:2010. Breakout quoted spherical. Supply and Extract quoted hemispherical. For in-duct data, end reflections are added based on the spigot size of the unit.

## Performance (Sentinel Econiq S)

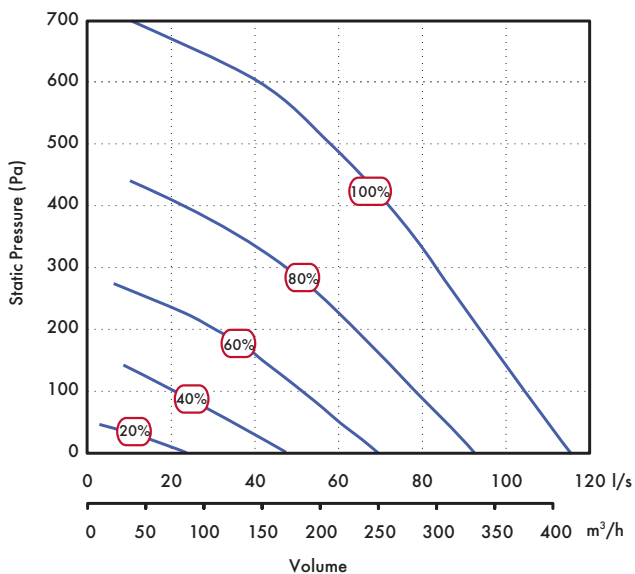

## Acoustic Solution

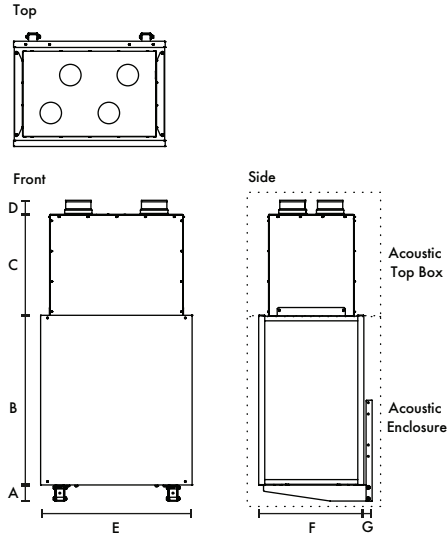

Acoustic Top Box		Acoustic Enclosure		kg	kg	Spigot			
A	B	C	D						
80	840	501	68	750	520	40	14	27	125

## Sound Spectrum (Solution Top Box & Enclosure Kit)

Speed	Test mode	Octave Band (Hz) Sound Power Levels, dB								LwA	SPL dB(A) @ 3m
		63	125	250	500	1k	2k	4k	8k		
20%	Supply	54.7	50.5	41.5	30.8	18.6	14.7	18.2	24.0	38.0	20.5
	Extract	54.8	41.7	31.4	20.2	15.2	13.8	18.3	24.3	31.9	14.4
	Breakout	36.6	47.3	38.0	24.7	19.3	16.6	19.1	23.6	34.0	13.5
40%	Supply	61.0	57.7	56.0	39.0	27.5	16.6	18.4	24.1	48.9	31.4
	Extract	55.7	50.8	44.6	26.8	19.1	15.0	18.2	24.0	39.2	21.7
	Breakout	55.9	55.2	48.2	35.5	29.9	20.9	20.4	25.3	42.6	22.1
60%	Supply	64.5	64.3	56.2	48.6	36.0	22.8	19.0	24.2	52.3	34.8
	Extract	59.4	57.3	46.6	36.0	25.6	17.4	18.6	24.5	43.9	26.4
	Breakout	43.5	60.5	49.5	43.5	39.0	32.0	23.8	23.7	47.6	27.1
80%	Supply	68.9	65.9	59.9	53.9	41.4	29.3	21.6	24.7	55.9	38.4
	Extract	63.1	69.3	52.6	43.0	33.4	23.7	20.2	24.6	54.5	37.0
	Breakout	48.3	69.8	52.7	48.3	44.7	39.8	33.2	25.9	57.1	36.6
100%	Supply	72.5	70.5	63.1	56.1	43.9	33.0	23.7	25.2	59.3	41.8
	Extract	70.3	61.9	56.2	45.4	36.6	28.0	22.9	24.6	51.5	34.0
	Breakout	54.3	67.1	63.3	51.3	47.9	43.9	38.5	28.7	57.7	37.2

## Spigot Configuration (Sentinel Econiq S)

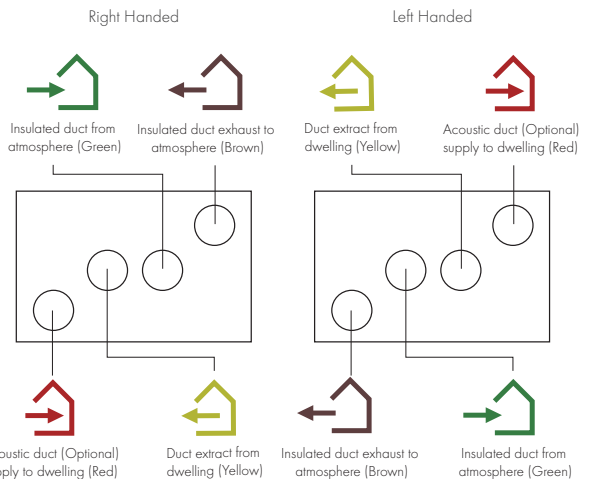

Hand-able through controller (except if pre-heater fitted)

# Sentinel Econiq M & L

## Dimensions (mm) (Sentinel Econiq M & L)

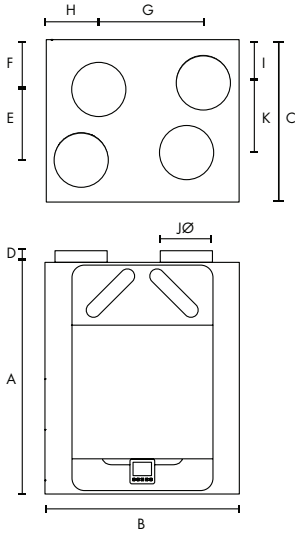

A	B	C	D	E	F	G	H	I	JØ	K	kg
881	728	608	50	261	187	394	200	160	200	261	50

Packed weight: 55kg

## Spigot Configuration (Sentinel Econiq M & L)

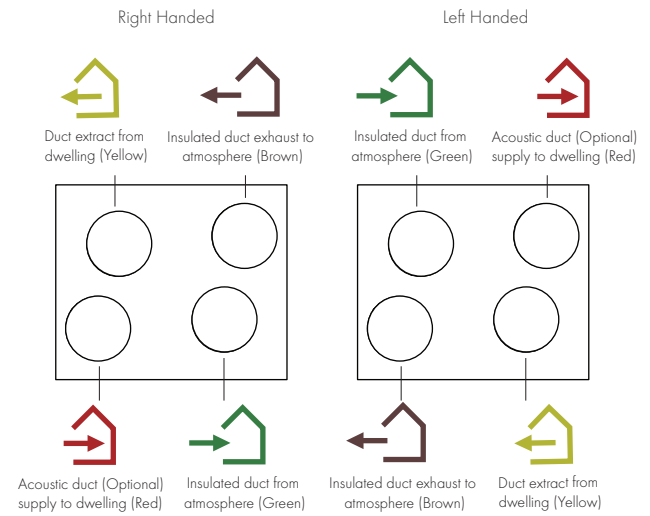

## Sound Spectrum (Sentinel Econiq M)

Speed	Test mode	Octave Band (Hz) Sound Power Levels, dB								SPL dB(A) @ 3m
		63	125	250	500	1k	2k	4k	8k	
20%	Breakout	32	41	35	31	24	17	19	23	12
	Inlet	48	42	33	23	19	14	17	22	13
	Outlet	55	55	48	41	34	23	18	22	27
40%	Breakout	36	45	46	42	36	25	19	23	22
	Inlet	54	45	43	33	31	20	18	22	21
	Outlet	64	58	57	52	49	40	26	22	37
60%	Breakout	43	50	51	48	44	36	22	23	29
	Inlet	59	51	51	39	39	29	20	22	28
	Outlet	69	64	65	58	58	51	38	26	45
80%	Breakout	48	55	56	53	50	43	30	24	34
	Inlet	65	56	57	46	44	37	26	22	34
	Outlet	73	68	67	64	63	59	47	35	50
100%	Breakout	60	60	57	58	55	47	36	29	38
	Inlet	69	59	54	48	48	41	31	24	35
	Outlet	76	70	67	69	66	63	53	42	53

## Sound Spectrum (Sentinel Econiq L)

Speed	Test mode	Octave Band (Hz) Sound Power Levels, dB								SPL dB(A) @ 3m
		63	125	250	500	1k	2k	4k	8k	
20%	Breakout	41	41	51	47	40	18	19	23	26
	Inlet	50	43	42	38	31	16	18	23	21
	Outlet	57	56	53	47	40	29	19	24	31
40%	Breakout	41	44	53	52	43	32	20	23	31
	Inlet	60	48	50	38	37	26	19	23	27
	Outlet	68	62	62	56	55	49	33	24	42
60%	Breakout	44	50	55	56	48	42	27	23	34
	Inlet	63	54	59	44	43	37	24	23	35
	Outlet	71	67	67	62	62	59	46	34	49
80%	Breakout	55	54	54	60	52	47	36	24	38
	Inlet	69	60	55	50	48	43	33	24	36
	Outlet	78	72	66	70	67	65	56	44	54
100%	Breakout	67	67	58	72	58	50	42	27	50
	Inlet	81	64	58	57	51	47	39	27	42
	Outlet	91	76	69	74	70	69	62	50	58

## Performance (Sentinel Econiq M)

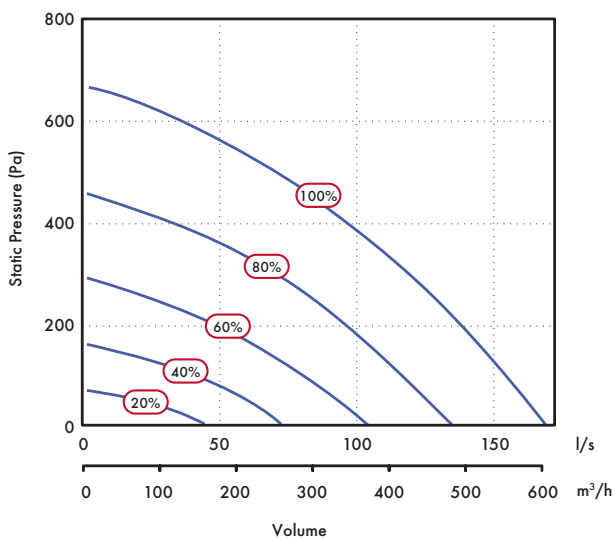

## Performance (Sentinel Econiq L)

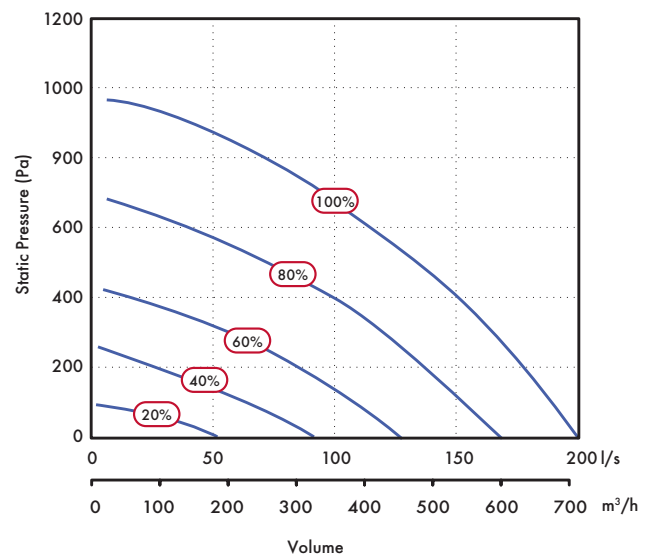



# Sentinel-X Controllers

## Battery Controllers & Sensors



### Battery - Internal Temperature and Humidity - Wireless

Room mounted humidity and temperature sensor for wired or wireless communication with a compatible system. Using an in-built RF 868 MHz (Wireless radio frequency), or RS485 (Wired connection) communication method whilst being powered by batteries.

- Dimensions (HxWxD) (mm) 60 x 60 x 22
- 2 x AAA Batteries included
- Temperature range 0~60°C
- Relative humidity range 0-90% RH
- Wireless range 20m closed/100m open
- RF 868MHz Wireless or RS485 Wired communication
- Status LED indicator for pairing, health check and fault conditions
- Mounted using provided back plate

Stock Ref

496431



### Battery - 4 Speed Switch with Temperature and Humidity - Wireless

Room mounted Speed Switch for wireless communication with a compatible system. Using an in-built RF 868 MHz (Wireless radio frequency) communication whilst being powered by batteries.

- Dimensions (HxWxD) (mm) 90 x 90 x 17
- 2 x AAA Batteries included
- Temperature range 0~60°C
- Relative humidity range 0-90% RH
- Wireless range 20m closed/100m open
- RF 868MHz Wireless
- Mounted using provided back plate or compatible with a standard single gang or surface mounted pattress box
- Status LED indicator for pairing, health check and fault conditions

Model

Stock Ref

White

496437

Black

497689

## HMI Kit



### Wall-mounted HMI Kit to suit Econiq models with full HMI

Includes HMI Blank controller, HMI backplate and cable.

- Dimensions (HxWxD) (mm) 90 x 90 x 17
- Power supply 240V
- Wireless range 20m closed/100m open
- RF 868MHz Wireless or RS485 Wired communication
- Compatible with standard single gang or surface mounted pattress box

Stock Ref

411628

## 24V Sensor



### 0-10V CO<sub>2</sub>, Temperature and Humidity - Wired

Room mounted CO<sub>2</sub> sensor with 0-10V signal output powered by an external 24V supply.

- Dimensions (HxWxD) (mm) 90 x 90 x 17
- 24V Power supply required
- Temperature range 0~60°C
- Relative humidity range 0-90% RH
- CO<sub>2</sub> range 0-2000PPM
- Compatible with standard single gang or surface mounted pattress box
- Status LED indicator for pairing, health check, faults & air quality traffic light index
- 0-10V Wired Communication

Stock Ref

496432

# Sentinel-X Controllers

## 240V Controllers & Sensors



### 240V - Internal Temperature and Humidity - Wireless

Room mounted humidity and temperature sensor for wired or wireless communication with a compatible system. Using an in-built RF 868 MHz (Wireless radio frequency), or RS485 (Wired connection) communication method whilst being powered by a local 240V supply.

- Dimensions (HxWxD) (mm) 90 x 90 x 17
- Power supply 240V
- Temperature range 0~60°C
- Relative humidity range 0-90% RH
- Wireless range 20m closed/100m open
- RF 868MHz Wireless or RS485 Wired communication
- Compatible with standard single gang or surface mounted pattress box
- Status LED indicator for pairing, health check, faults & air quality traffic light index

Stock Ref  
**496429**



### 240V - CO<sub>2</sub>, Temperature and Humidity - Wireless

Room mounted CO<sub>2</sub> sensor for wired or wireless communication with a compatible system. Using an in-built RF 868 MHz (Wireless radio frequency), or RS485 (Wired connection) communication method whilst being powered by a local 240V supply.

- Dimensions (HxWxD) (mm) 90 x 90 x 17
- Power supply 240V
- Temperature range 0~60°C
- Relative humidity range 0-90% RH
- CO<sub>2</sub> Range 0-2000 PPM
- Wireless range 20m closed/100m open
- RF 868MHz Wireless or RS485 Wired communication
- Compatible with standard single gang or surface mounted pattress box
- Status LED indicator for pairing, health check, faults & air quality traffic light index

Stock Ref  
**496433**



### 240V - 4 Speed Switch with Temperature and Humidity - Wired

Room mounted Speed Switch for wired communication with a compatible system. Using an in-built RS485 communication method powered by a local 240V supply.

- Dimensions (HxWxD) (mm) 90 x 90 x 17
- Power Supply 240V
- Temperature range 0~60°C
- Relative humidity range 0-90% RH
- Mounted using provided back plate or compatible with standard single gang or surface mounted pattress box
- Status LED indicator for pairing, health check and fault conditions
- RS485 Wired Connection

Model  
White  
Black

Stock Ref  
**496621**  
**497697**



### 240V - 4 Speed Switch with Temperature and Humidity - Wireless

Room mounted Speed Switch for wireless communication with a compatible system. Using an in-built RF 868 MHz (Wireless radio frequency) communication whilst being powered by a local 240V supply.

- Dimensions (HxWxD) (mm) 90 x 90 x 17
- Power Supply 240V
- Temperature range 0~60°C
- Relative humidity range 0-90% RH
- Wireless range 20m closed/100m open
- RF 868MHz Wireless
- Mounted using provided back plate or compatible with standard single gang or surface mounted pattress box
- Status LED indicator for pairing, health check and fault conditions

Model  
White  
Black

Stock Ref  
**496620**  
**497693**



### 240V - PIR Sensor - Wireless

Room mounted PIR sensor for wired or wireless communication with a compatible system. Using an in-built RF 868 MHz (Wireless radio frequency), or RS485 (Wired connection) communication method whilst being powered by a local 240V supply. Room mounted presence detector for min/max or on/off control. Wall or ceiling mounting.

- Dimensions (HxWxD) (mm) 90 x 90 x 17
- Power supply 240V
- 5-25min run on timer
- PIR Range 3m
- Compatible with standard single gang or surface mounted pattress box
- Wireless range 20m closed/100m open
- RF 868MHz Wireless or RS485 Wired communication

Stock Ref  
**496438**

# Lo-Carbon Sentinel Kinetic<sup>®</sup> BH

- Recognised in SAP PCDB
- Lightweight for easier installation
- Horizontal duct option for space-saving installations
- Fits within a 290mm deep kitchen cupboard
- Integrated digital controller for simple and accurate commissioning
- Plug and play controls; Humidistat
- BMS connectivity
- LS inputs (Light Switch)
- Horizontal duct options
- Acoustic Enclosure option for reduced breakout noise
- Acoustic Top Box option for reduced in-duct noise



## Easy Installation

The Sentinel Kinetic models can be mounted vertically in a roof space, hallway cupboard or kitchen or within a kitchen cupboard. When mounted in an unheated area ducting and MVHR unit should be insulated. Ducting can be attached to the unit horizontally, vertically or both. Minimum internal depth of kitchen cupboard 290mm.

For scenarios where noise is a critical issue, an Acoustic Enclosure is available to reduce breakout noise and the Acoustic Top Box will reduce in-duct noise at key frequencies.

**Left (L) or right (R) hand installation.** The unit is supplied with duct spigots to outside on the right hand side. These can be reversed on site by simply removing the control panel, rotating the unit 180 degrees and re-attaching the control panel.

## Spigot Options

The combination of spigot options allows installation in confined locations. If vertical and horizontal connection is required on the same outlet/inlet, additional spigots can be supplied.

The condensate drain can be taken out through the back, side or bottom of the unit. Using the fittings supplied, the final condensate connection is made outside the unit and can be completed after installation.

## Integral Humidity Sensor (BH Models)

The integral humidity sensor increases speed in proportion to relative humidity levels, saving energy and reducing noise. The sensor also reacts to small but rapid increases in humidity, even if the normal trigger threshold is not reached. This unique feature ensures adequate ventilation, even for the smallest wet room. The night time relative humidity setback feature suppresses nuisance tripping as humidity gradually increases with falling temperature.

## Models

Model	Stock Ref
Kinetic VS Right	438342
Kinetic BH Right	443319
Kinetic BH Right with Acoustic Enclosure & Top Box	479526
Kinetic BH Right with Acoustic Top Box	479525
Kinetic BH Right with Acoustic Enclosure	479524
Kinetic BH Left	443319L
Kinetic BH Left with Acoustic Enclosure & Top Box	479529
Kinetic BH Left with Acoustic Top Box	479528
Kinetic BH Left with Acoustic Enclosure (BH with summer bypass & humidity sensor)	479527

## Accessories

Model	Stock Ref
Wired Remote Controller	443283
LED alarm with 15m cable	448356
Acoustic Purge Fan	477988
Acoustic Purge Fan XL	479829
ISO 45% Coarse (G3) 2x Filter	442356
ISO ePM10 50% Pollen (M5) 1x Filter	444199
Anti Vibration Mounts	68MP033G

## SAP PCDB performance (Kinetic VS)

	SAP 2009		SAP 2012	
	Thermal		Thermal	
	Efficiency %	SFP (W/l/s)	Efficiency %	SFP (W/l/s)
K+1	90	0.60	90	0.61
K+2	90	0.59	90	0.74
K+3	90	0.68	90	0.95
K+4	89	0.79	90	1.19
K+5	90	0.97	-	-

## SEC Class

Model	SEC Class
Kinetic VS & BH	A

## Dimensions (mm)

Unit

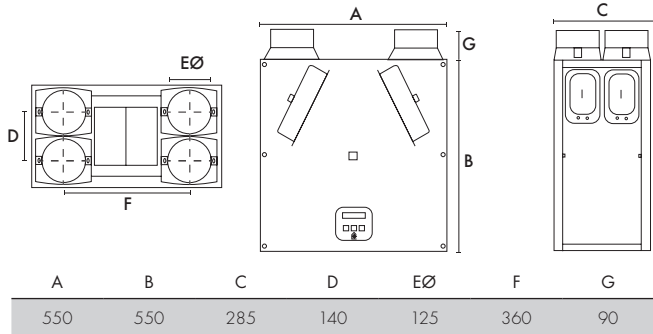

Weight: 15kg

## Acoustic Solution

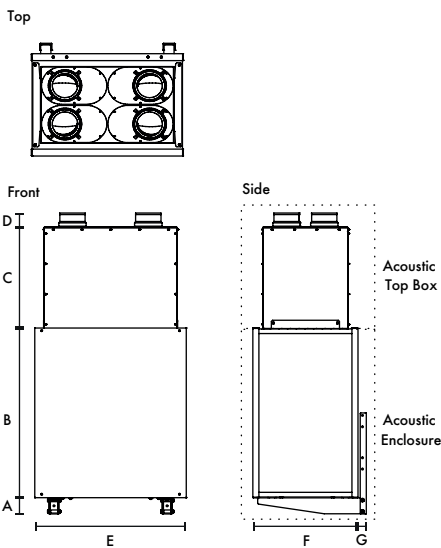

Acoustic Acoustic Top Box Enclosure

A	B	C	D	E	F	G	kg	kg	Spigot
80	633	501	75	626	447	45	11	19	125

## Sound Data (Kinetic VS & BH)

Speed	Test mode	Octave band, Hz, dB SWL								SPL dB(A) @ 3m	
		63	125	250	500	1k	2k	4k	8k		LwA
20%	Supply	52.9	52.9	46.5	41.7	39.3	29.3	19.3	22.8	44.4	26.9
	Extract	50.7	41.9	37.4	34.5	29.8	17.7	17.4	22.7	35.7	18.2
	Breakout	36	34.5	33.6	34.3	33.8	27.2	22.2	25.3	37.2	16.7
40%	Supply	57.1	64.1	56.8	50.6	49.7	41.1	32.8	26.4	54.7	37.2
	Extract	55.2	50.3	44.9	43	38.3	27.7	19.8	22.9	43.8	26.3
	Breakout	43.5	41.7	40.4	41.3	41.7	36.1	27.8	26.2	44.7	24.2
60%	Supply	71.3	72.5	68.5	57.6	56.4	51.1	42.7	38.1	63.6	46.1
	Extract	60.2	56.3	52	48.8	44.8	35.5	26.9	24.4	50.2	32.7
	Breakout	50.7	47.8	47.7	47.7	48.3	44.9	36.7	30	51.8	31.3
80%	Supply	66.3	74.8	71.2	62.8	61	56.3	49.8	46.7	67.3	49.8
	Extract	63.8	59.4	57.6	53.8	49.2	41.2	33.5	29	55.0	37.5
	Breakout	54.4	52.7	54	52.7	53.5	50.3	43.6	37.7	57.2	36.7
100%	Supply	70.3	75.7	73.9	66.3	63.5	59.7	53.2	50.6	70.0	52.5
	Extract	66.6	63.9	60.9	56.5	51.2	44.2	36.8	32.6	57.9	40.4
	Breakout	59.1	55.2	56.8	55.6	56.1	53.5	47.1	41.6	60.1	39.6

Tested according to BS EN 13141-7:2010. Breakout quoted spherical. Supply and Extract quoted hemispherical. For in-duct data, end reflections are added based on the spigot size of the unit.

## Performance

Fan speeds are fully adjustable within the performance range.

### Vertical Spigots

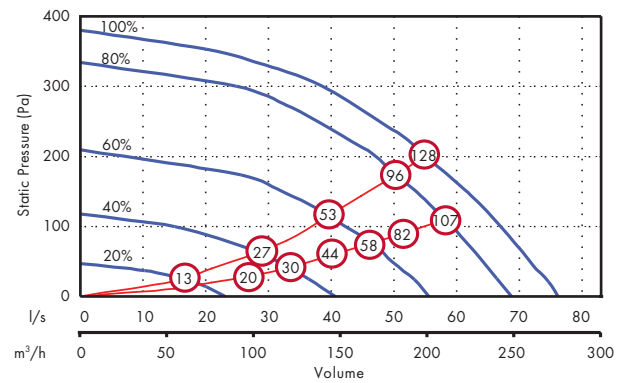

### Horizontal Spigots

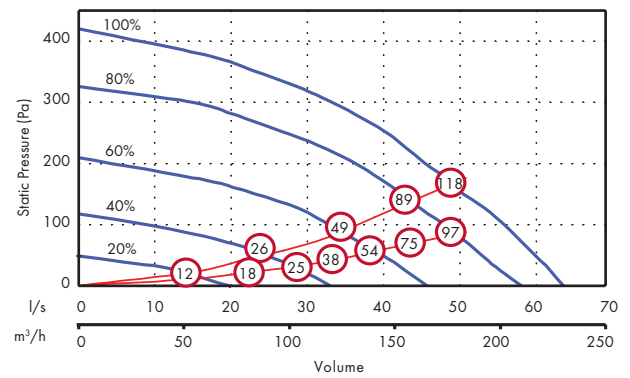

⊗ figure relates to Wattage (both motors)

## Sound Data (Kinetic VS & BH with Acoustic Solution)

Speed	Test mode	Octave band, Hz, dB SWL								SPL dB(A) @ 3m	
		63	125	250	500	1k	2k	4k	8k		LwA
20%	Supply	57.1	44.6	36.4	27.9	20.6	14.8	18.1	23.8	35.2	17.7
	Extract	54.4	40.1	29.6	22.2	17.5	14.5	17.8	23.5	31.1	13.6
	Breakout	37.5	33.8	29.1	22.9	17.0	14.0	17.8	23.6	27.7	7.2
40%	Supply	64.9	56.3	46.4	36.1	28.2	15.4	18.1	23.8	44.6	27.1
	Extract	60.2	46.8	35.7	28.2	21.9	14.8	18.1	23.7	36.6	19.1
	Breakout	46.0	43.6	36.3	30.4	23.9	15.9	18.1	23.6	33.5	13.0
60%	Supply	72.3	63.0	55.6	43.1	34.1	19.5	18.6	24.0	51.9	34.4
	Extract	61.4	53.3	43.4	34.7	27.2	15.5	18.1	23.8	41.4	23.9
	Breakout	52.2	50.5	44.4	38.2	33.5	23.8	19.3	23.8	41.0	20.5
80%	Supply	73.8	67.9	61.6	50.0	38.6	23.4	20.2	25.2	56.8	39.3
	Extract	68.6	58.2	50.5	40.5	31.1	17.2	18.2	23.9	47.5	30.0
	Breakout	65.6	55.5	50.5	43.8	39.7	32.7	24.9	24.0	47.4	26.9
100%	Supply	77.3	70.8	64.9	53.8	41.4	26.3	21.9	26.8	60.1	42.6
	Extract	71.5	60.6	53.5	43.9	33.4	19.1	18.5	24.0	50.5	33.0
	Breakout	69.0	58.4	53.4	47.1	43.0	37.5	29.9	24.9	51.1	30.6

## Consultant's Specification

### Operation

The supply and extract ventilation unit shall be a Sentinel Kinetic as manufactured by Vent-Axia and shall be sized as indicated on the drawings and shall be in accordance with the particular specification.

Supply air to the room shall be pre-heated by the extract air via the integrated composite plastic counterflow heat recovery cell. The Sentinel Kinetic shall automatically vary the ventilation rate via EC/DC motors, as it receives signals from one of the optional interconnected sensors. When a signal is received, the fans shall either vary their speed proportionally or on a trickle and boost principle.

The unit shall have the facility to commission the supply and extract fans individually via in-built minimum and maximum speed adjustment, or alternative wired remote control unit. The fans themselves shall have independent, infinitely variable speed control.

### Unit Specification

The unit shall be manufactured with an ABS outer case construction, and incorporate a reversible core to allow for left or right hand mounting.

The unit shall have a high efficiency composite plastic counterflow heat exchanger, supply and extract filters, automatic summer bypass, integral minimum and maximum infinitely variable speed controls with fascia mounted failure indication. The unit shall have low energy, high efficiency EC/DC fan/motor assemblies with sealed for life bearings. The impellers shall be high efficiency forward curved centrifugal type.

The unit shall have a heat exchanger cell with a thermal efficiency of up to 91.1% when tested to EN 308. This shall be protected by ISO 45% Coarse (G3) grade synthetic filters on supply and extract. Complete with a condensate drip tray and drain connection.

The unit shall be constructed with a removable Core allowing full maintenance access. The removable Core shall provide access to the following:

- ✓ Supply and extract filter
- ✓ Heat exchanger
- ✓ Access to the electrical connections

To reduce breakout noise, the MVHR unit shall be provided with an Acoustic Enclosure of steel construction lined with class 'O' acoustic foam. To reduce in-duct noise, the top of the MVHR shall be fitted with an Acoustic Top Box to provide attenuation to the 4 ducts of the unit. This Acoustic Top Box shall be of steel construction lined with acoustic class 'O' foam with the MVHR spigots linked to the Top Box via 4 separate attenuated ducts. The acoustic enclosure and top box shall each be independently tested for noise to BS EN 13141-7.

The MVHR unit shall incorporate an Expanded Polystyrene (EPS) inner chassis with custom motor and impeller mounting features. The inner chassis will assist in reducing noise and act as a large anti-vibration mount avoiding transmission through to the back mounting plate or the base of the unit.

The MVHR unit shall be tested to ensure it meets the maximum allowable vibration of no more than 1 mm/s, measured on the unit wall fixing points.

Access shall be provided for wiring termination and setup/commissioning. The backlit LCD user interface therein shall be removable for remote mounting if required.

Units shall be as manufactured by Vent-Axia Ltd.

### Standard Controls

All Sentinel Kinetic units shall incorporate the following functions integrally mounted, pre-wired and factory fitted by the manufacturer:

- ✓ Integral infinitely variable fan speed control on supply and extract
- ✓ Integral min/max ventilation control/set point
- ✓ Integral BMS interfaces - control and status indication
- ✓ Heating interlocks
- ✓ 0-10V proportional speed adjustment
- ✓ Volt free contacts
- ✓ 24V sensor supply
- ✓ Integral on/off or trickle boost function from remote switch e.g. PIR occupancy detector
- ✓ The unit shall be controlled by the 'Sentinel' control devices (enablers and sensors) as detailed in the schedule or on the drawings
- ✓ Fully automatic summer bypass
- ✓ Switched Live input with adjustable 'delay-on' feature
- ✓ Fan failure or component failure indicated via individual fault code display
- ✓ Running time counter
- ✓ Control panel PIN number lock
- ✓ Automatic frost protection effective to -20°C
- ✓ Tool free filter access
- ✓ The unit shall incorporate ('H' models) an integral humidity sensor with the following features:
  - Ambient Response; Raises the humidity trigger point as dwelling temperature reduces
  - Rapid Response; Monitors the rate of change in humidity and triggers increased airflow even if the humidity trigger threshold is not reached
  - Proportional Response; Incrementally increases the fan speed to reduce noise and reduce energy consumption

### Mounting Option

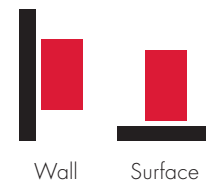

## Airflow Direction

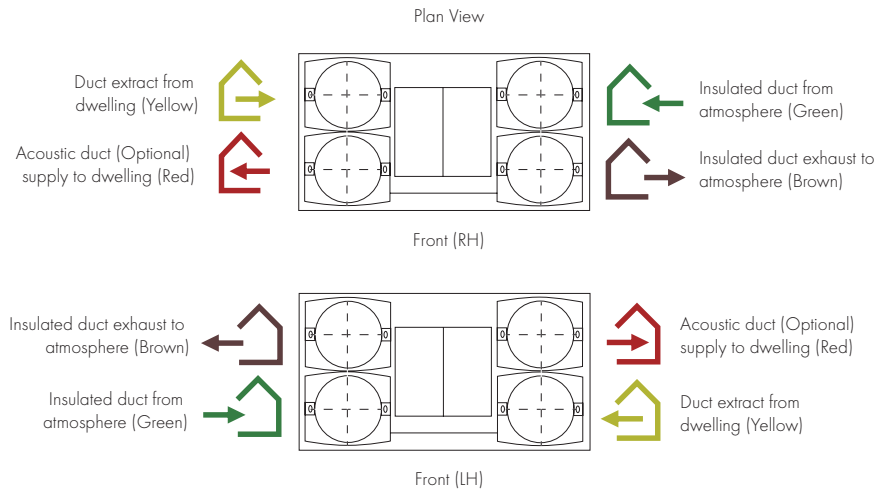

## Electrical Connection

Please note: Electrical connection should be carried out by an appropriately qualified person and in accordance with current wiring regulations.

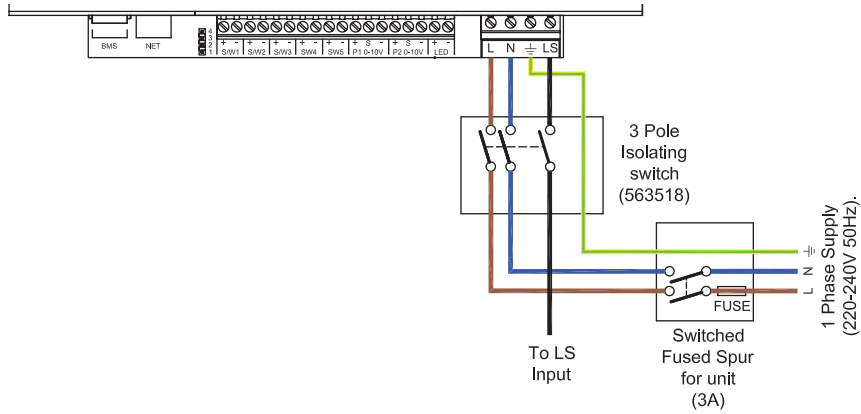

## Trickle to Boost by Trickle/Boost Switch

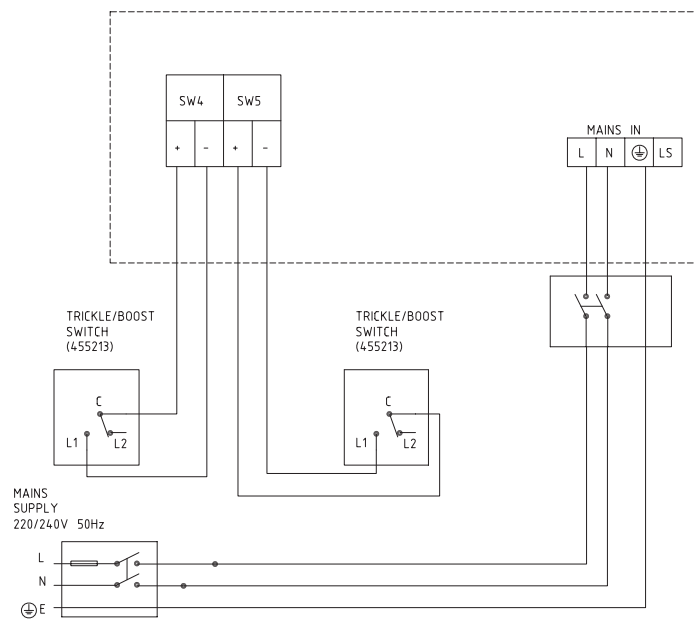



# Lo-Carbon Sentinel Kinetic<sup>®</sup> FH

- Acoustic Enclosure option for reduced breakout noise
- Acoustic Top Box option for reduced in-duct noise
- Lightweight for easier installation
- Horizontal duct option for space-saving installations
- Integrated digital controller for simple and accurate commissioning
- Plug and play controls; Humidistat
- BMS connectivity
- LS inputs (Light Switch)
- Volt-free inputs
- Self diagnosis for simplified fault finding
- Adjustable delay On/delay Off timer



## Easy Installation

The Sentinel Kinetic models can be mounted vertically in a roof space or in an appropriate cupboard within the dwelling. When mounted in an unheated area the ducting and unit must be insulated in accordance with the Domestic Ventilation Compliance Guide. Ducting can be attached to the unit horizontally, vertically or both.

For scenarios where noise is a critical issue, an Acoustic Enclosure is available to reduce breakout noise and the Acoustic Top Box will reduce in-duct noise at key frequencies.

**Left (L) or right (R) hand installation.** Left hand and right hand units are available.

## Spigot Options

The combination of spigot options allows installation in confined locations. If vertical and horizontal connection is required on the same outlet/inlet, additional spigots can be supplied.

The condensate drain can be taken out through the back, side or bottom of the unit. Using the fittings supplied, the final condensate connection is made outside the unit and can be completed after installation.

## Integral Humidity Sensor

The integral humidity sensor increases speed in proportion to relative humidity levels, saving energy and reducing noise. The sensor also reacts to small but rapid increases in humidity, even if the normal trigger threshold is not reached. This unique feature ensures adequate ventilation, even for the smallest wet room. The night time relative humidity setback feature suppresses nuisance tripping as humidity gradually increases with falling temperature.

## Model

Model	Stock Ref
Sentinel Kinetic FH Right	408167
Sentinel Kinetic FH Right with Acoustic Top Box & Enclosure	479532
Sentinel Kinetic FH Right with Acoustic Top Box	479531
Sentinel Kinetic FH Right with Acoustic Enclosure	479530
Sentinel Kinetic FH Left	408169
Sentinel Kinetic FH Left with Acoustic Top Box & Enclosure	479535
Sentinel Kinetic FH Left with Acoustic Top Box	479534
Sentinel Kinetic FH Left with Acoustic Enclosure	479533

(FH comes with summer bypass & humidity sensor)

## Accessories

Model	Stock Ref
Wired Remote Controller	443283
LED alarm with 15m cable	448356
ISO 45% Coarse (G3) 2x Filter	409764
ISO ePM10 50% Pollen (M5) 2x Filter	472153
Anti Vibration Mounts	68MP033G
Acoustic Purge Fan	477988
Acoustic Purge Fan XL	479829

## SAP PCDB performance (Model 408167A)

	SAP 2009		SAP 2012	
	Thermal		Thermal	
	Efficiency %	SFP (W/l/s)	Efficiency %	SFP (W/l/s)
K+1	90	0.46	89	0.47
K+2	89	0.45	88	0.54
K+3	88	0.50	86	0.65
K+4	86	0.60	84	0.84
K+5	85	0.70	84	1.01

## SEC Class

Model	SEC Class
Kinetic FH/FHL	A+

## Dimensions (mm)

Unit

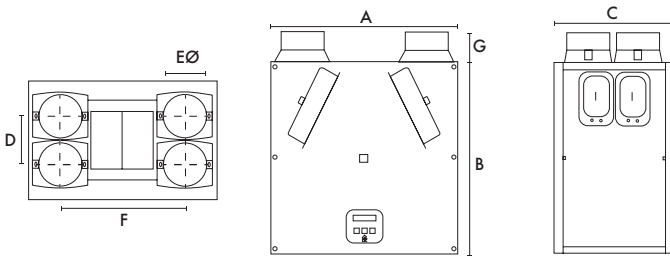

A	B	C	D	EØ	F	G
555	550	350	140	125	360	90

Weight: 18kg

## Acoustic Solution

Top

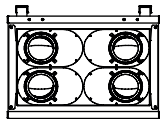

Front

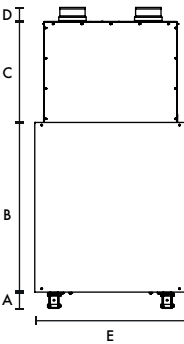

Side

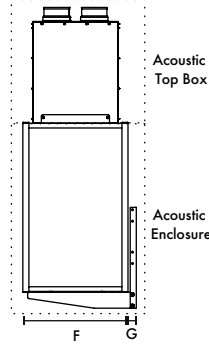

Acoustic Acoustic  
Top Box Enclosure

A	B	C	D	E	F	G	kg	kg	Spigot
80	633	501	75	626	447	45	11	19	125

## Performance

Fan speeds are fully adjustable within the performance range.

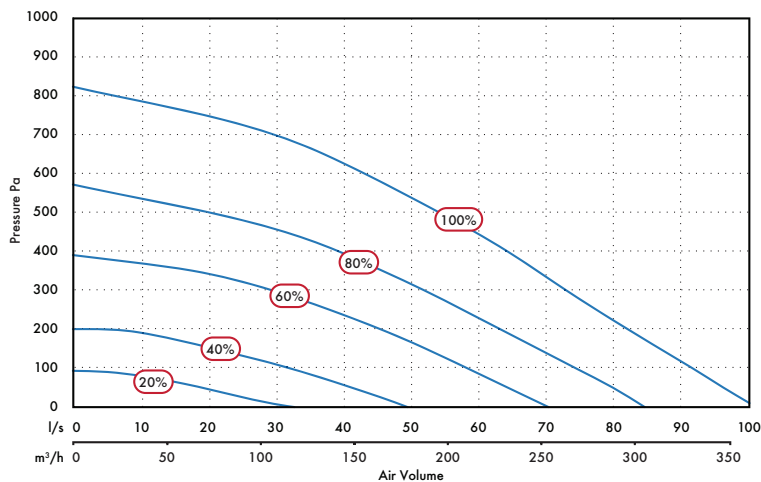

## Sound Data (Unit only)

Speed Test mode	Port	Octave band, Hz, dB SWL								SPL dB(A)	
		63	125	250	500	1k	2k	4k	8k	LwA	@ 3m
20%	Supply	66.2	67.2	54.3	48.0	42.1	33.3	22.5	25.6	53.9	36.4
	Extract	57.7	56.6	47.2	43.5	35.3	24.1	19.6	25.7	45.7	28.2
	Breakout	41.2	47.0	41.7	39.5	34.6	30.4	22.5	25.7	41.0	20.5
40%	Supply	68.9	66.4	68.8	57.8	52.1	44.9	35.3	28.8	62.4	44.9
	Extract	66.8	56.1	56.9	52.1	44.7	34.6	23.8	25.8	53.2	35.7
	Breakout	47.3	47.5	56.4	48.0	44.0	39.6	32.8	29.1	51.0	30.5
60%	Supply	72.8	72.5	82.2	64.4	59.9	53.8	46.2	40.3	74.4	56.9
	Extract	67.3	61.9	66.5	58.9	52.2	42.7	32.6	27.6	61.1	43.6
	Breakout	53.9	53.2	65.9	55.8	52.2	48.2	42.5	39.3	61.0	40.5
80%	Supply	85.0	75.3	72.5	77.9	65.3	58.8	52.1	47.4	76.0	58.5
	Extract	83.5	65.2	65.0	65.5	57.0	47.7	37.9	31.3	65.5	48.0
	Breakout	56.4	56.4	60.4	69.8	56.7	53.2	47.8	42.0	66.5	46.0
100%	Supply	95.5	77.7	74.0	80.4	68.7	62.9	56.9	52.4	79.1	61.6
	Extract	83.3	68.3	66.9	71.2	60.7	51.4	42.4	36.1	69.7	52.2
	Breakout	62.1	59.7	62.9	70.0	61.0	57.3	52.3	46.9	68.0	47.5

## Sound Data (Unit with Acoustic Solution)

Speed Test mode	Port	Octave band, Hz, dB SWL								SPL dB(A)	
		63	125	250	500	1k	2k	4k	8k	LwA	@ 3m
20%	Supply	58.2	62.1	46.8	33.7	21.1	14.1	18.2	24.1	47.5	30.0
	Extract	55.9	48.3	37.1	26.8	17.7	14.5	18.0	23.7	36.2	18.7
	Breakout	41.8	45.1	38.7	29.1	18.4	13.7	17.8	23.5	34.7	14.2
40%	Supply	66.5	59.3	59.3	43.5	30.5	15.9	17.9	23.5	52.1	34.6
	Extract	57.4	49.7	50.9	36.2	23.5	15.0	18.1	23.7	43.5	26.0
	Breakout	47.1	47.6	49.8	38.4	30.2	21.0	18.5	23.6	42.6	22.1
60%	Supply	69.5	66.0	66.5	50.7	40.2	20.6	18.8	24.2	59.3	41.8
	Extract	62.4	57.1	53.7	43.2	32.5	19.5	18.5	23.8	48.0	30.5
	Breakout	51.8	54.5	54.4	45.2	38.9	32.1	24.4	24.0	49.0	28.5
80%	Supply	78.5	68.9	63.3	61.3	45.1	25.7	20.7	25.8	61.0	43.5
	Extract	74.2	59.8	55.8	49.9	37.8	24.4	20.5	23.9	52.4	34.9
	Breakout	57.6	57.6	56.4	52.0	43.7	38.0	31.6	25.6	52.2	31.7
100%	Supply	75.7	70.8	67.1	65.7	48.2	30.4	23.6	27.8	64.6	47.1
	Extract	75.6	62.9	59.5	53.1	42.2	29.4	24.3	24.7	55.7	38.2
	Breakout	64.3	59.8	60.3	56.8	47.1	42.2	36.9	28.8	56.4	35.9

Tested according to BS EN 13141-7:2010. Breakout quoted spherical. Supply and Extract quoted hemispherical. For in-duct data, end reflections are added based on the spigot size of the unit.

## Consultant's Specification

### Operation

The supply and extract ventilation unit shall be a Sentinel Kinetic as manufactured by Vent-Axia and shall be sized as indicated on the drawings and shall be in accordance with the particular specification.

Supply air to the room shall be pre-heated by the extract air via the integrated composite plastic counterflow heat recovery cell. The Sentinel Kinetic shall automatically vary the ventilation rate via EC/DC motors, as it receives signals from one of the optional interconnected sensors. When a signal is received, the fans shall either vary their speed proportionally or on a trickle and boost principle.

The unit shall have the facility to commission the supply and extract fans individually via in-built minimum and maximum speed adjustment, or alternative wired remote control unit. The fans themselves shall have independent, infinitely variable speed control.

### Unit Specification

The unit shall be manufactured with an ABS outer case construction, and incorporate a reversible core to allow for left or right hand mounting.

The unit shall have a high efficiency composite plastic counterflow heat exchanger, supply and extract filters, automatic summer bypass, integral minimum and maximum infinitely variable speed controls with fascia mounted failure indication. The unit shall have low energy, high efficiency EC/DC fan/motor assemblies with sealed for life bearings. The impellers shall be high efficiency backward curved centrifugal type.

The unit shall have a heat exchanger cell with a thermal efficiency of up to 90% when tested to EN 308. This shall be protected by ISO 45% Coarse (G3) grade synthetic filters on supply and extract. Complete with a condensate drip tray and drain connection.

To reduce breakout noise, the MVHR unit shall be provided with an Acoustic Enclosure of steel construction lined with class 'O' acoustic foam. To reduce in-duct noise, the top of the MVHR shall be fitted with an Acoustic Top Box to provide attenuation to the 4 ducts of the unit. This Acoustic Top Box shall be of steel construction lined with acoustic class 'O' foam with the MVHR spigots linked to the Top Box via 4 separate attenuated ducts. The acoustic enclosure and top box shall each be independently tested for noise to BS EN 13141-7.

The MVHR unit shall incorporate an Expanded Polystyrene (EPS) inner chassis with custom motor and impeller mounting features. The inner chassis will assist in reducing noise and act as a large anti-vibration mount avoiding transmission through to the back mounting plate or base of the unit.

The MVHR unit will be tested to ensure it meets the maximum allowable vibration of no more than 1 mm/s, measured on the unit wall fixing points.

The unit shall be constructed with a removable Core allowing full maintenance access. The removable Core shall provide access to the following:

- ✓ Supply and extract filter
- ✓ Heat exchanger
- ✓ Access to the electrical connections

Access shall be provided for wiring termination and setup/commissioning. The backlit LCD user interface therein shall be removable for remote mounting if required.

Units shall be as manufactured by Vent-Axia Ltd.

Acoustically tested to BS EN 13141-7

### Standard Controls

All Sentinel Kinetic units shall incorporate the following functions integrally mounted, pre-wired and factory fitted by the manufacturer:

- ✓ Integral infinitely variable fan speed control on supply and extract
- ✓ Integral min/max ventilation control/set point
- ✓ Integral BMS interfaces – control and status indication
- ✓ Heating interlocks
- ✓ 0-10V proportional speed adjustment
- ✓ Volt free contacts
- ✓ 24V sensor supply
- ✓ Integral on/off or trickle boost function from remote switch e.g. PIR occupancy detector
- ✓ The unit shall be controlled by the 'Sentinel' control devices (enablers and sensors) as detailed in the schedule or on the drawings
- ✓ Fully automatic summer bypass
- ✓ Switched Live input with adjustable 'delay-on' feature
- ✓ Fan failure or component failure indicated via individual fault code display
- ✓ Running time counter
- ✓ Control panel PIN number lock
- ✓ Automatic frost protection effective to -20°C
- ✓ Tool free filter access
- ✓ The unit shall incorporate ('H' models) an integral humidity sensor with the following features:
  - Ambient Response; Raises the humidity trigger point as dwelling temperature reduces
  - Rapid Response; Monitors the rate of change in humidity and triggers increased airflow even if the humidity trigger threshold is not reached
  - Proportional Response; Incrementally increases the fan speed to reduce noise and reduce energy consumption

## Airflow Direction

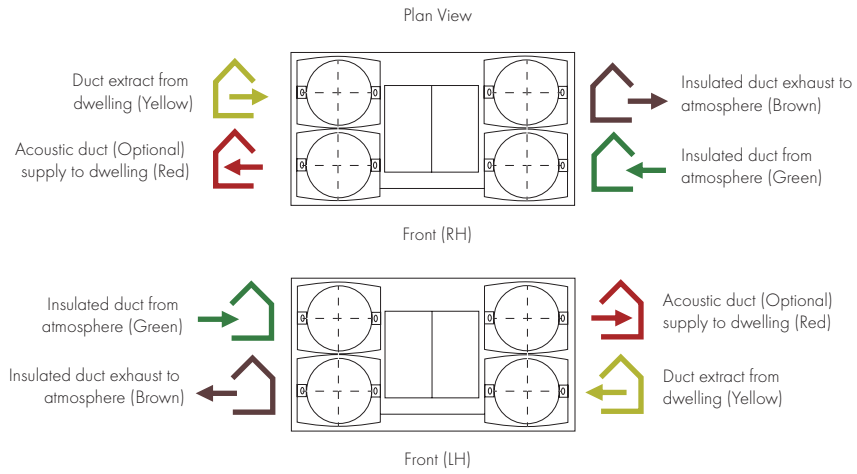

## Electrical Connection

Please note: Electrical connection should be carried out by an appropriately qualified person and in accordance with current wiring regulations.

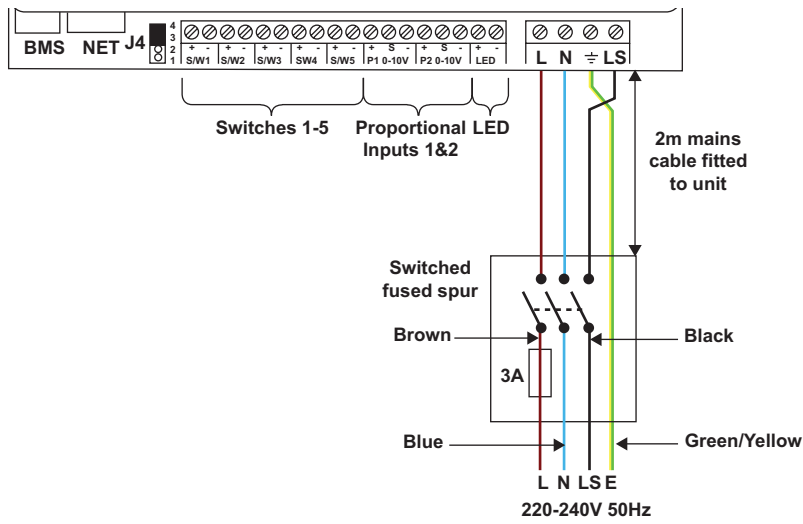

## Trickle to Boost by Trickle/Boost Switch

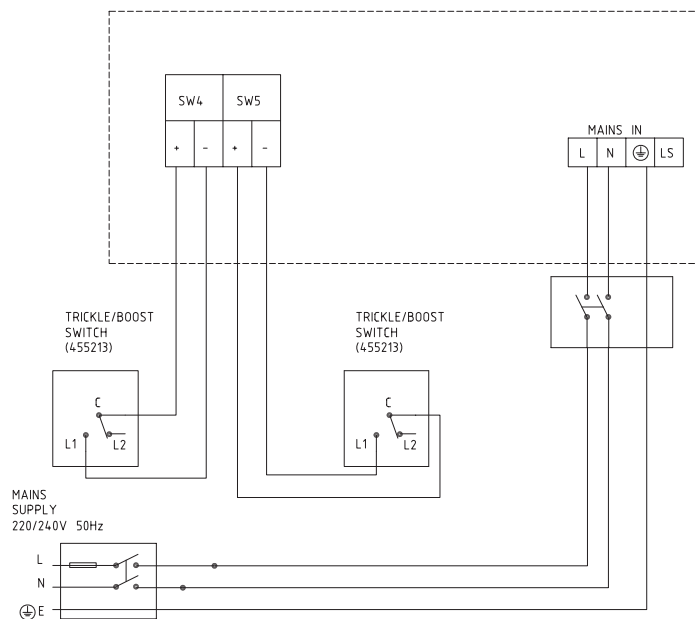

# Lo-Carbon Sentinel Kinetic<sup>®</sup> Plus

- Acoustic Enclosure option for reduced breakout noise
- Acoustic Top Box option for reduced in-duct noise
- Recognised in SAP PCDB
- Horizontal duct option for space-saving installations
- High airflow, ideal for student accommodation clusters
- Unique folding filter for removal when access is restricted
- Integrated digital controller for simple and accurate commissioning
- Plug and play controls; Humidistat
- BMS connectivity
- LS inputs (Light Switch)
- Volt-free inputs
- Self diagnosis for simplified fault finding
- Adjustable delay On/delay Off timer
- 4 fully adjustable speeds and a purge setting



## Increased Performance

The Sentinel Kinetic Plus benefits from the latest high efficiency, backward curved impeller design, ensuring the lowest possible energy consumption, ultra quiet operation and an exceptional performance range covering small one bed apartments to the largest of houses.

For scenarios where noise is a critical issue, an Acoustic Enclosure is available to reduce breakout noise and the Acoustic Top Box will reduce in-duct noise at key frequencies.

## Care Homes & Student Accommodation

The Sentinel Kinetic Plus is ideal for larger homes and multiple occupancy units such as care homes and student accommodation. Capable of 400m<sup>3</sup>/hr at 150Pa, the unit can extract from up to ten bathrooms and a communal kitchen while still achieving almost 90% heat recovery. The fully automatic capability of the Kinetic range means that adequate ventilation is always achieved.

The Kinetic's BMS capability is also ideal for those commercial applications where landlords or property managers want to monitor and optimise building performance and maintenance. The Kinetic BMS can provide status information and its self diagnostics can report if any fault is found.

## Spigot Options

Spigots may be re-positioned to give horizontal connection or a combination of vertical and horizontal connection.

Optional 180mm/200mm spigots can simplify connection in commercial installations where larger diameter duct work has been used.

## Quick Change Filter

As many systems are placed within cupboards the unique filter design folds as you remove it to ensure easy access in restricted spaces.

## Integral Humidity Sensor

The integral humidity sensor increases speed in proportion to relative humidity levels, saving energy and reducing noise. The sensor also reacts to small but rapid increases in humidity, even if the normal trigger threshold is not reached. This unique feature ensures adequate ventilation, even for the smallest wet room. The night time relative humidity setback feature suppresses nuisance tripping as humidity gradually increases with falling temperature.

## Models

Model	Stock Ref
Sentinel Kinetic Plus BS	447938
Sentinel Kinetic Plus Right	443028
Sentinel Kinetic Plus Right with Acoustic Top Box & Enclosure	479538
Sentinel Kinetic Plus Right with Acoustic Top Box	479537
Sentinel Kinetic Plus Right with Acoustic Enclosure	479536
Sentinel Kinetic Plus Left	443028L
Sentinel Kinetic Plus Left with Acoustic Top Box & Enclosure	479541
Sentinel Kinetic Plus Left with Acoustic Top Box	479540
Sentinel Kinetic Plus Left with Acoustic Enclosure	479539

## Accessories

Model	Stock Ref
Wired Remote Controller	443283
LED Alarm with 15m cable	448356
Opto-coupler for volt-free BMS connection	447340
ISO 45% Coarse (G3) 2x Filter	403702
ISO ePM10 50% Pollen (M5) 1x Filter	444201
180mm/200mm Spigot Kit (One per pack)	446523
Anti Vibration Mounts	68MP033G
Acoustic Purge Fan	477988
Acoustic Purge Fan XL	479829

## SAP PCDB Test Results (Kinetic Plus BS)

	SAP 2009		SAP 2012	
	Thermal Efficiency %	SFP (W/l/s)	Thermal Efficiency %	SFP (W/l/s)
K+1	91	0.51	91	0.42
K+2	91	0.40	91	0.44
K+3	90	0.41	90	0.52
K+4	90	0.45	90	0.63
K+5	90	0.53	90	0.76
K+6	90	0.60	91	0.90
K+7	90	0.70	91	1.05

## SEC Class

Model	SEC Class
Kinetic Plus	A+

## Dimensions (mm)

Unit

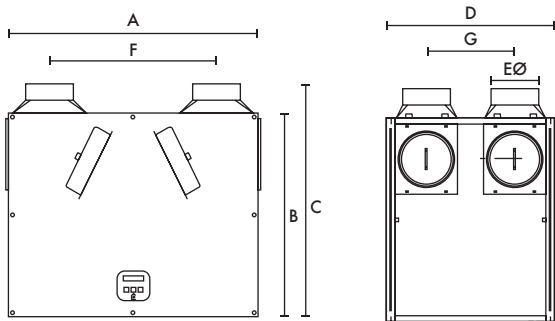

A	B	C	D	EØ	F	G
785	635	722	550	150	520	275

Weight: 24kg

## Performance

Fan speeds are fully adjustable within the performance range.

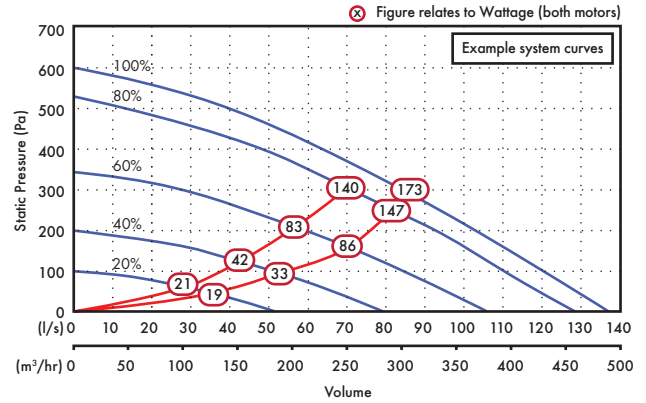

## Acoustic Solution

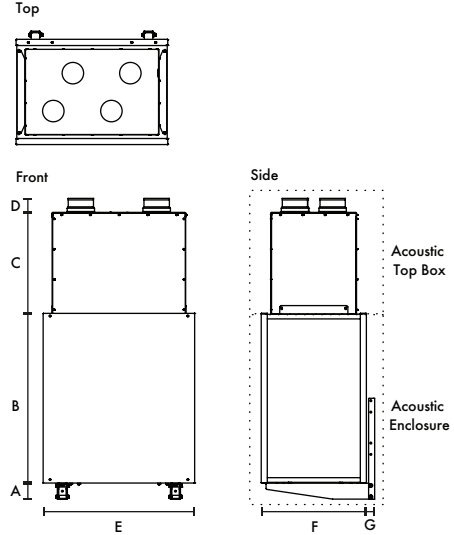

A	B	C	D	E	F	G	kg	kg	Spigot
80	733	501	71	855	583	40	17	33	150

## Sound Data (Unit only)

Unit setting	Test mode	Octave band, Hz, dB SWL										SPL dB(A) at 3m
		63	125	250	500	1k	2k	4k	8k	LwA		
20%	Supply	54.4	60.9	50.6	45.9	34.3	23.6	19.1	24.5	51.3	30.8	
	Extract	48.4	56.7	43.7	35.9	21.4	16	18.7	24.5	42.3	24.8	
	Breakout	42.6	40.2	39.6	38	31.1	24.3	19.4	24.6	35.1	17.6	
40%	Supply	61.6	64.6	58.4	55.5	45.9	37.2	24.7	25.1	58.8	38.3	
	Extract	54.9	62.2	51.5	44.8	32.1	24.1	19.7	24.6	48.8	31.3	
	Breakout	51.1	49.3	48.9	45.9	41.3	35.7	26.7	25.6	44.0	26.5	
60%	Supply	67.5	67.5	73.2	62.4	53.4	47.5	33.5	28.3	69.2	48.7	
	Extract	62.5	61.7	60.1	51.1	39.2	32.1	23.2	24.8	54.0	36.5	
	Breakout	54.9	53	58.4	55.1	49.7	43.9	35.4	31.9	52.8	35.3	
80%	Supply	70.5	71.1	73.8	66.5	58.3	53.2	39.7	33.3	71.3	50.8	
	Extract	68.4	65.9	71.8	55.6	43.6	37.1	27.3	25.5	63.8	46.3	
	Breakout	59.2	56.8	63.6	57.3	54.2	49	41	37.5	56.8	39.3	
100%	Supply	72.8	73.1	75.2	70.4	61.6	56.6	44.2	37.6	73.9	53.4	
	Extract	71.7	69	71.8	57.4	45.7	39.9	30.9	26.6	64.1	46.6	
	Breakout	61.2	58.8	67.9	59.6	56.7	52.2	44.4	41.2	60.1	42.6	

## Sound Data (Unit with Acoustic Solution)

Unit setting	Test mode	Octave band, Hz, dB SWL										SPL dB(A) at 3m
		63	125	250	500	1k	2k	4k	8k	LwA		
20%	Supply	55.7	49.2	36.6	23.6	17.4	14.9	17.8	23.3	36.1	18.6	
	Extract	51.4	42.4	30.3	20.9	16.8	14.9	17.8	23.3	30.8	13.3	
	Breakout	37.4	39.7	30.0	22.7	15.6	14.0	17.9	23.3	28.4	7.9	
40%	Supply	59.7	59.7	45.5	32.2	22.2	15.2	17.9	23.3	45.1	27.6	
	Extract	54.8	55.0	38.0	26.8	18.1	14.9	17.8	23.3	40.2	22.7	
	Breakout	45.7	48.5	39.9	32.8	24.2	17.5	18.0	23.4	36.8	16.3	
60%	Supply	66.1	61.9	53.6	41.0	29.8	18.3	18.0	23.3	49.5	32.0	
	Extract	60.6	55.9	48.4	34.9	23.8	16.3	17.9	23.3	43.8	26.3	
	Breakout	51.1	51.0	52.4	40.9	33.2	26.1	19.7	23.4	44.5	24.0	
80%	Supply	70.0	67.6	68.5	48.1	37.9	25.3	19.4	23.6	60.7	43.2	
	Extract	65.4	59.7	57.2	41.6	31.3	21.8	19.2	23.4	50.4	32.9	
	Breakout	55.6	55.6	57.9	47.9	40.4	34.3	26.1	23.7	51.3	30.8	
100%	Supply	72.1	70.1	66.4	51.6	41.9	29.7	21.7	24.0	60.0	42.5	
	Extract	68.2	62.4	60.6	45.5	36.0	26.6	21.7	23.6	53.8	36.3	
	Breakout	57.6	58.8	63.3	51.0	44.2	38.5	31.0	24.9	56.3	35.8	

Tested according to BS EN 13141-7:2010. Breakout quoted spherical. Supply and Extract quoted hemispherical. For in-duct data, end reflections are added based on the spigot size of the unit.



## Consultant's Specification

### Operation

The supply and extract ventilation unit shall be as Sentinel Kinetic Plus as manufactured by Vent-Axia and shall be sized as indicated on the drawings and shall be in accordance with the particular specification.

Supply air to the room shall be pre-heated by the extract air via the integrated composite plastic counterflow heat recovery cell. The Sentinel Kinetic Plus shall automatically vary the ventilation rate via EC/DC motors, as it receives signals from one of the optional interconnected sensors.

When a signal is received, the fans shall either vary their speed proportionally or on a trickle and boost principle.

The unit shall have the facility to commission the supply and extract fans individually via in-built minimum and maximum speed adjustment, or alternative wired remote control unit. The fans themselves shall have independent, infinitely variable speed control.

### Unit Specification

The unit shall be manufactured with an ABS outer case construction, and incorporate a reversible core to allow for left or right hand mounting.

The unit shall have a high efficiency composite plastic counterflow heat exchanger, supply and extract filters, automatic summer bypass, integral minimum and maximum infinitely variable speed controls with fascia mounted failure indication.

The unit shall have low energy, high efficiency EC/DC fan/motor assemblies with sealed for life bearings. The impellers shall be high efficiency backward curved centrifugal type.

The unit shall have a heat exchanger cell with a thermal efficiency of up to 92% when tested to EN 308. This shall be protected by ISO 45% Coarse (G3) grade synthetic filters on supply and extract. Complete with a condensate drip tray and drain connection.

To reduce breakout noise, the MVHR unit shall be provided with an Acoustic Enclosure of steel construction lined with class '0' acoustic foam. To reduce in-duct noise, the top of the MVHR shall be fitted with an Acoustic Top Box to provide attenuation to the 4 ducts of the unit. This Acoustic Top Box shall be of steel construction lined with acoustic class '0' foam with the MVHR spigots linked to the Top Box via 4 separate attenuated ducts. The acoustic enclosure and top box shall each be independently tested for noise to BS EN 13141-7.

The unit shall be constructed with a removable Core allowing full maintenance access. The removable Core shall provide access to the following:

- ✓ Supply and extract filter
- ✓ Heat exchanger
- ✓ Access to the electrical connections

Access shall be provided for wiring termination and setup/commissioning. The backlit LCD user interface therein may be duplicated for remote mounting if required.

Units shall be as manufactured by Vent-Axia Ltd.

The MVHR unit shall incorporate an Expanded Polystyrene (EPS) inner chassis with custom motor and impeller mounting features. The inner chassis will assist in reducing noise and act as a large anti-vibration mount to avoid transmission through to the back mounting plate or the base of the unit.

The MVHR unit shall be tested to ensure it meets the maximum allowable vibration of no more than 1 mm/s, measured on the unit wall fixing points.

Sound tested to BS EN 13141-7:2010

### Standard Controls

All Sentinel Kinetic units shall incorporate the following functions integrally mounted, pre-wired and factory fitted by the manufacturer:

- ✓ Integral infinitely variable fan speed control on supply and extract
- ✓ Integral min/max ventilation control/set point
- ✓ Integral BMS input/output interfaces - control and status indication
- ✓ Heating interlocks
- ✓ 0-10V proportional speed adjustment
- ✓ Volt free contacts
- ✓ 24V sensor supply
- ✓ Integral on/off or trickle boost function from remote switch, e.g. PIR occupancy detector
- ✓ Fully automatic summer bypass
- ✓ Switched Live input with adjustable 'delay-on' feature
- ✓ Fan failure or component failure indicated via individual fault code display
- ✓ Running time counter
- ✓ Control panel PIN number lock
- ✓ Automatic frost protection effective to -20°C
- ✓ The unit shall incorporate an integral humidity sensor with the following features:
  - Ambient Response; Raises the humidity trigger point as dwelling temperature reduces
  - Rapid Response: Monitors the rate of change in humidity and triggers increased airflow even if the humidity trigger threshold is not reached
  - Proportional Response; Incrementally increases the fan speed to reduce noise and reduce energy consumption
- ✓ The unit shall be controlled by the 'Sentinel' control devices (enablers and sensors) as detailed in the schedule or on the drawings.
- ✓ Tool free filter access

### Mounting Option

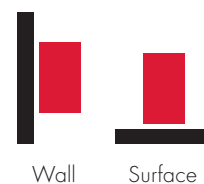

## Airflow Direction

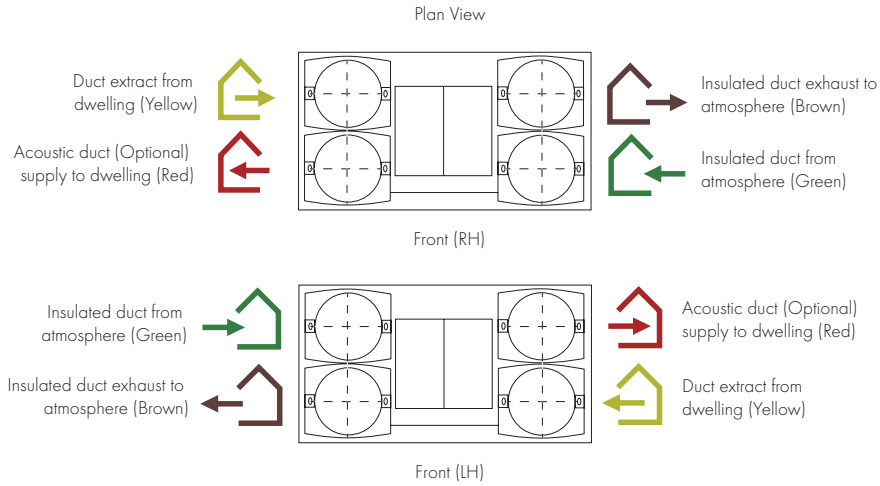

## Electrical Connection

Please note: Electrical connection should be carried out by an appropriately qualified person and in accordance with current wiring regulations.

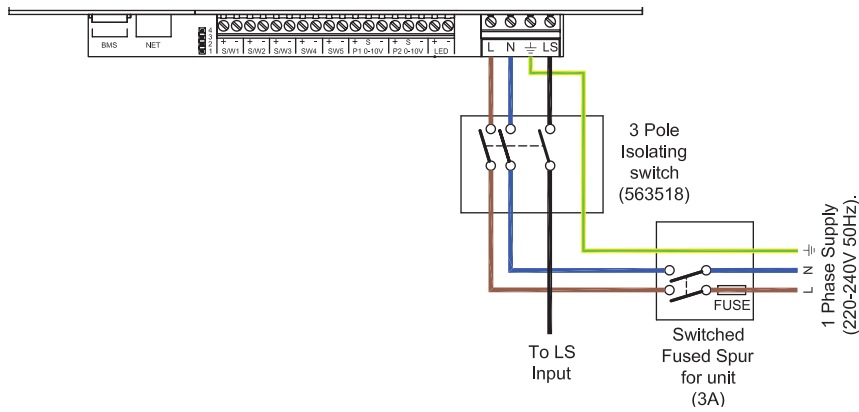

## Trickle to Boost by two lighting circuits or Trickle/Boost Switch

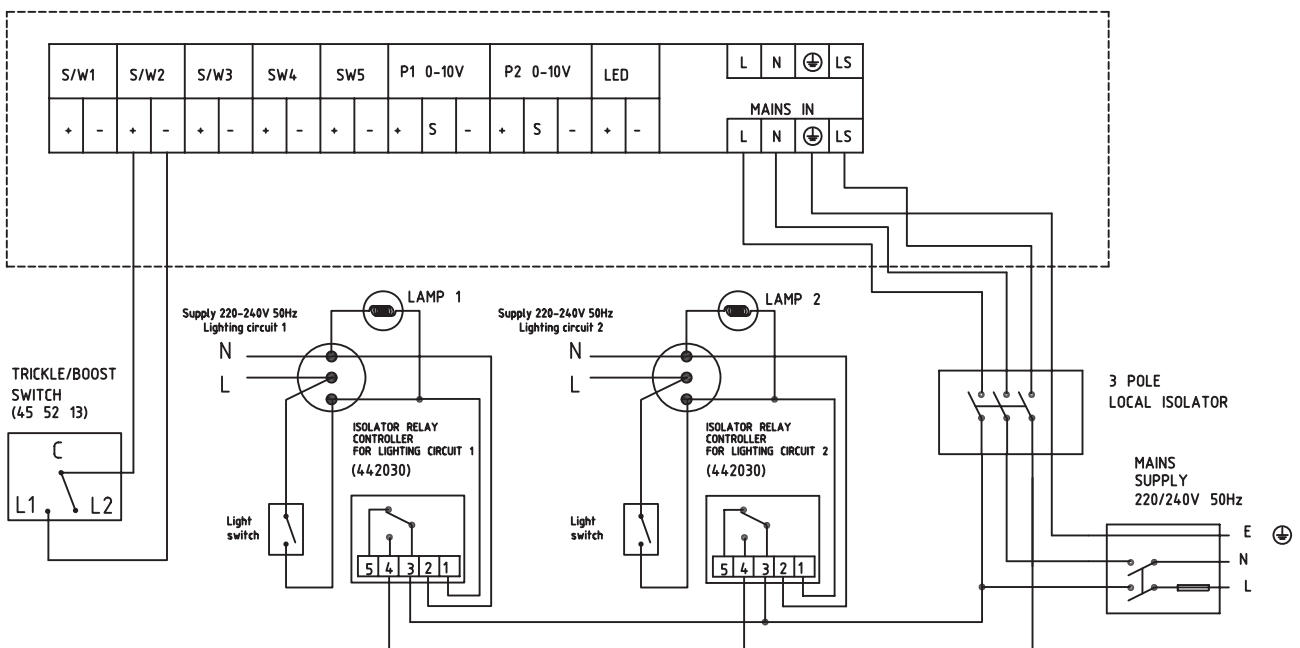

# Lo-Carbon Sentinel Kinetic<sup>®</sup> High Flow

- Acoustic Enclosure option for reduced breakout noise
- Acoustic Top Box option for reduced in-duct noise
- Recognised in SAP PCDB
- 180mm/200mm spigots
- Horizontal duct option for space-saving installations
- High airflow, ideal for student accommodation clusters
- Unique folding filter for removal when access is restricted
- Integrated digital controller for simple and accurate commissioning
- Plug and play controls; Humidistat
- BMS connectivity
- LS inputs (Light Switch)
- Volt-free inputs



## Increased Performance

The Sentinel Kinetic High Flow benefits from the latest high efficiency, backward curved impeller design, ensuring the lowest possible energy consumption, and an exceptional performance range covering small one bed apartments to the largest of houses.

For scenarios where noise is a critical issue, an Acoustic Enclosure is available to reduce breakout noise and the Acoustic Top Box will reduce in-duct noise at key frequencies.

## Care Homes & Student Accommodation

The Sentinel Kinetic High Flow is ideal for larger homes and multiple occupancy units such as care homes and student accommodation. Capable of 175l/s at 150Pa, the unit can extract from up to fourteen bathrooms and a communal kitchen while still achieving almost 90% heat recovery. The fully automatic capability of the Kinetic range means that adequate ventilation is always achieved.

The Kinetic's BMS capability is also ideal for those commercial applications where landlords or property managers want to monitor and optimise building performance and maintenance. The Kinetic BMS can provide status information and its self diagnostics can report if any fault is found.

## Spigot Options

180mm/200mm Spigots may be re-positioned to give horizontal connection or a combination of vertical and horizontal connection.

## Quick Change Filter

As many systems are placed within cupboards the unique filter design folds as you remove it to ensure easy access in restricted spaces.

## Integral Humidity Sensor

The integral humidity sensor increases speed in proportion to relative humidity levels, saving energy and reducing noise. The sensor also reacts to small but rapid increases in humidity, even if the normal trigger threshold is not reached. This unique feature ensures adequate ventilation, even for the smallest wet room. The night time relative humidity setback feature suppresses nuisance tripping as humidity gradually increases with falling temperature.

## Models

Model	Stock Ref
Kinetic High Flow Right	408449
Kinetic High Flow Right with Acoustic Top Box & Enclosure	479544
Kinetic High Flow Right with Acoustic Top Box	479543
Kinetic High Flow Right with Acoustic Enclosure	479542
Kinetic High Flow Left	408451
Kinetic High Flow Left with Acoustic Top Box & Enclosure	479547
Kinetic High Flow Left with Acoustic Top Box	479546
Kinetic High Flow Left with Acoustic Enclosure	479545

For further details, see Sentinel Kinetic Plus.

## Accessories

Model	Stock Ref
Wired Remote Controller	443283
LED Alarm with 15m cable	448356
Opto-coupler for volt-free bms connection	447340
ISO 45% Coarse (G3) 2x Filter	403702
ISO ePM10 50% Pollen (M5) 1x Filter	444201
Anti Vibration Mounts	68MP033G
Acoustic Purge Fan	477988
Acoustic Purge Fan XL	479829

## SAP PCDB Test Results

	SAP 2009		SAP 2012	
	Thermal Efficiency %	SFP (W/l/s)	Thermal Efficiency %	SFP (W/l/s)
K + 1	88	0.65	88	0.58
K + 2	88	0.54	90	0.55
K + 3	90	0.52	91	0.60
K + 4	90	0.55	91	0.69
K + 5	91	0.6	90	0.78
K + 6	91	0.66	90	0.92
K + 7	90	0.74	90	1.09

## SEC Rating

Model	SEC Class
Kinetic High Flow	A

## Dimensions (mm)

Unit

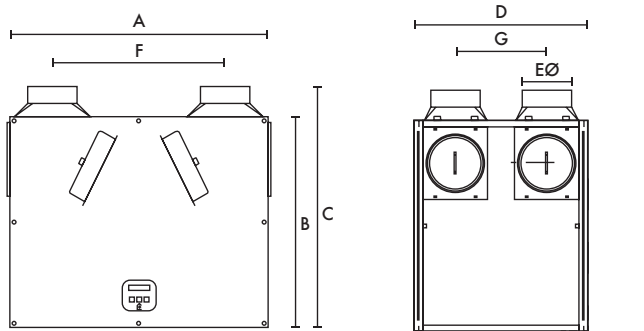

A	B	C	D	EØ	F	G
785	635	722	550	180/200	520	275

Weight: 31kg

## Sound Data (Unit only)

Flow %	Test Mode	Octave band, Hz, dB SWL								SPL dB(A)	
		63	125	250	500	1K	2K	4K	8K	LwA	@ 3m
20	Supply	55.1	65.9	55.2	53.8	44.4	37.4	25.3	24.9	66.8	34.1
	Extract	58.2	57.4	48.0	45.6	43.8	34.5	20.0	24.5	61.3	27.9
	Breakout	43.3	46.6	44.9	44.7	41.8	30.4	21.6	22.5	51.6	25.1
40	Supply	63.1	69.0	67.1	64.0	55.0	51.6	39.7	32.4	64.2	43.7
	Extract	58.6	58.4	60.0	53.7	41.9	41.5	31.7	25.1	54.9	34.3
	Breakout	55.4	49.6	60.6	53.8	46.5	41.5	33.2	27.4	55.4	34.8
60	Supply	70.3	74.3	81.4	71.5	63.6	59.9	49.6	43.1	74.8	54.3
	Extract	64.4	64.2	72.6	59.1	48.7	45.7	37.8	29.3	64.9	44.4
	Breakout	62.8	54.6	65.7	57.2	55.5	49.2	41.4	36.4	61.0	40.5
80	Supply	75.3	77.9	88.1	78.7	68.4	65.1	56.0	50.1	81.4	60.9
	Extract	71.1	68.2	73.6	61.8	51.9	49.5	42.7	37.6	66.4	45.9
	Breakout	66.2	59.0	73.4	61.8	57.0	54.6	47.3	43.1	66.8	46.2
100	Supply	90.9	80.9	84.4	80.1	71.5	68.0	59.3	54.5	80.7	60.1
	Extract	92.4	71.8	78.1	67.4	54.9	51.5	44.6	41.4	72.2	51.7
	Breakout	69.3	62.9	74.9	67.5	59.2	56.6	49.1	44.7	69.3	48.8

Tested according to BS EN 13141-7:2010. Breakout quoted spherical. Supply and Extract quoted hemispherical.

## Performance

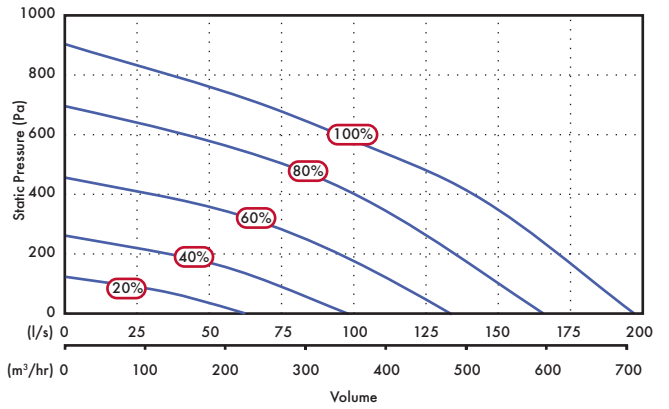

## Acoustic Solution

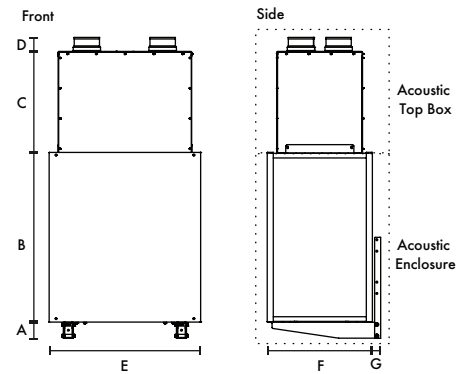

A	B	C	D	E	F	G	kg	kg	Spigot
80	733	501	71	855	583	40	17	33	180

## Sound Data (Unit with Acoustic Enclosure)

Flow %	Test Mode	Octave band, Hz, dB SWL								SPL dB(A)	
		63	125	250	500	1K	2K	4K	8K	LwA	@ 3m
20	Supply	55.2	57.0	46.1	38.8	24.0	15.4	18.0	23.2	43.6	26.1
	Extract	50.4	53.6	37.0	32.3	18.2	15.1	18.0	23.2	38.7	21.2
	Breakout	41.3	51.8	39.2	32.3	20.5	15.8	18.1	23.2	37.7	17.2
40	Supply	64.1	59.6	59.7	51.9	35.5	22.8	19.9	23.5	53.3	35.8
	Extract	56.6	50.7	49.0	41.9	24.5	17.7	18.1	23.2	43.3	25.8
	Breakout	46.7	50.5	53.0	44.8	32.2	22.2	18.5	23.3	45.6	25.1
60	Supply	67.3	64.0	67.7	58.6	43.2	30.6	26.5	25.9	61.0	43.5
	Extract	61.6	56.7	55.5	49.0	32.2	25.3	19.7	23.4	50.2	32.7
	Breakout	53.0	54.4	60.2	48.8	40.6	33.2	23.4	23.4	53.0	32.5
80	Supply	70.3	67.7	74.6	61.8	48.5	36.2	33.0	31.4	67.5	50.0
	Extract	66.7	60.0	67.2	50.9	38.1	32.8	24.0	24.1	59.7	42.2
	Breakout	58.0	58.0	64.7	52.4	45.7	39.9	31.2	24.3	58.7	38.2
100	Supply	73.0	70.1	77.1	65.1	51.4	39.5	37.0	36.4	70.1	52.6
	Extract	69.6	62.5	67.3	56.2	41.7	37.0	28.1	25.3	60.5	43.0
	Breakout	61.0	61.2	65.9	57.7	48.5	43.8	36.3	26.3	60.7	40.2

## Consultant's Specification

### Operation

The supply and extract ventilation unit shall be as Sentinel Kinetic High Flow as manufactured by Vent-Axia and shall be sized as indicated on the drawings and shall be in accordance with the particular specification.

Supply air to the room shall be pre-heated by the extract air via the integrated composite plastic counterflow heat recovery cell. The Sentinel Kinetic High Flow shall automatically vary the ventilation rate via EC/DC motors, as it receives signals from one of the optional interconnected sensors.

When a signal is received, the fans shall either vary their speed proportionally or on a trickle and boost principle.

The unit shall have the facility to commission the supply and extract fans individually via in-built minimum and maximum speed adjustment, or alternative wired remote control unit. The fans themselves shall have independent, infinitely variable speed control.

### Unit Specification

The unit shall be manufactured with an ABS outer case construction, and incorporate a reversible core to allow for left or right hand mounting.

The unit shall have a high efficiency composite plastic counterflow heat exchanger, supply and extract filters, automatic summer bypass, integral minimum and maximum infinitely variable speed controls with fascia mounted failure indication.

The unit shall have low energy, high efficiency EC/DC fan/motor assemblies with sealed for life bearings. The impellers shall be high efficiency backward curved centrifugal type.

The unit shall have a heat exchanger cell with a thermal efficiency of up to 92% when tested to EN 308. This shall be protected by ISO 45% Coarse (G3) grade synthetic filters on supply and extract. Complete with a condensate drip tray and drain connection.

To reduce breakout noise, the MVHR unit shall be provided with an Acoustic Enclosure of steel construction lined with class 'O' acoustic foam. To reduce in-duct noise, the top of the MVHR shall be fitted with an Acoustic Top Box to provide attenuation to the 4 ducts of the unit. This Acoustic Top Box shall be of steel construction lined with acoustic class 'O' foam with the MVHR spigots linked to the Top Box via 4 separate attenuated ducts. The acoustic enclosure and top box shall each be independently tested for noise to BS EN 13141-7.

The unit shall be constructed with a removable Core allowing full maintenance access. The removable Core shall provide access to the following:

- ✓ Supply and extract filter
- ✓ Heat exchanger
- ✓ Access to the electrical connections

Access shall be provided for wiring termination and setup/commissioning. The backlit LCD user interface therein may be duplicated for remote mounting if required.

Units shall be as manufactured by Vent-Axia Ltd.

The MVHR unit shall incorporate an Expanded Polystyrene (EPS) inner chassis with custom motor and impeller mounting features. The inner chassis will assist in reducing noise and act as a large anti-vibration mount to avoid transmission through to the back mounting plate or the base of the unit.

The MVHR unit shall be tested to ensure it meets the maximum allowable vibration of no more than 1 mm/s, measured on the unit wall fixing points.

Sound tested to BS EN 13141-7:2010

### Standard Controls

All Sentinel Kinetic units shall incorporate the following functions integrally mounted, pre-wired and factory fitted by the manufacturer:

- ✓ Integral infinitely variable fan speed control on supply and extract
- ✓ Integral min/max ventilation control/set point
- ✓ Integral BMS input/output interfaces - control and status indication
- ✓ Heating interlocks
- ✓ 0-10V proportional speed adjustment
- ✓ Volt free contacts
- ✓ 24V sensor supply
- ✓ Integral on/off or trickle boost function from remote switch, e.g. PIR occupancy detector
- ✓ Fully automatic summer bypass
- ✓ Switched Live input with adjustable 'delay-on' feature
- ✓ Fan failure or component failure indicated via individual fault code display
- ✓ Running time counter
- ✓ Control panel PIN number lock
- ✓ Automatic frost protection effective to -20°C
- ✓ The unit shall incorporate an integral humidity sensor with the following features:
  - Ambient Response; Raises the humidity trigger point as dwelling temperature reduces
  - Rapid Response: Monitors the rate of change in humidity and triggers increased airflow even if the humidity trigger threshold is not reached
  - Proportional Response; Incrementally increases the fan speed to reduce noise and reduce energy consumption
- ✓ The unit shall be controlled by the 'Sentinel' control devices (enablers and sensors) as detailed in the schedule or on the drawings.
- ✓ Tool free filter access

### Mounting Option

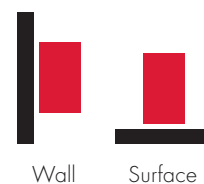

## Airflow Direction

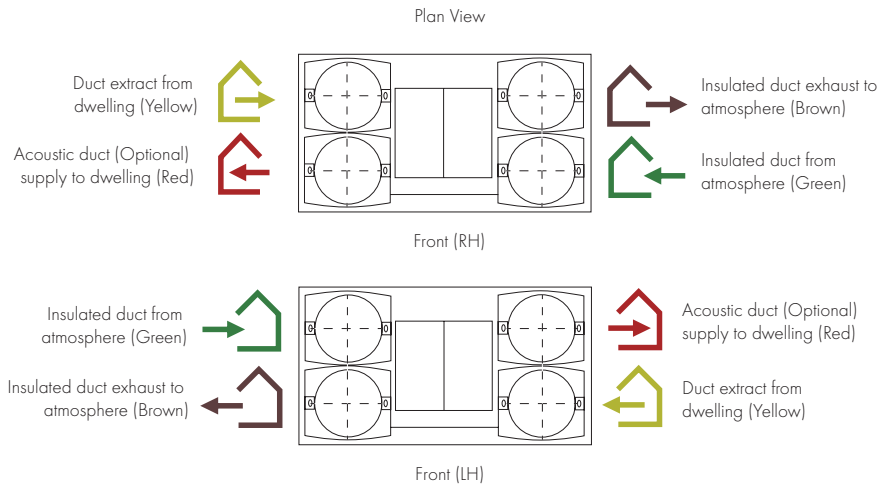

## Electrical Connection

Please note: Electrical connection should be carried out by an appropriately qualified person and in accordance with current wiring regulations.

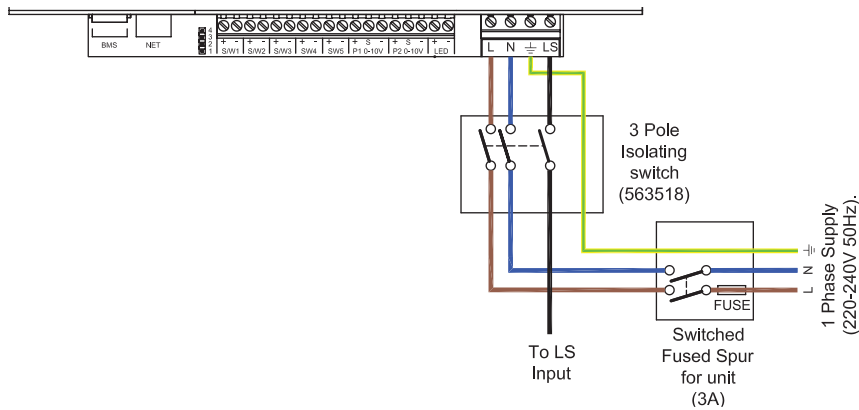

## Trickle to Boost by two lighting circuits or Trickle/Boost Switch

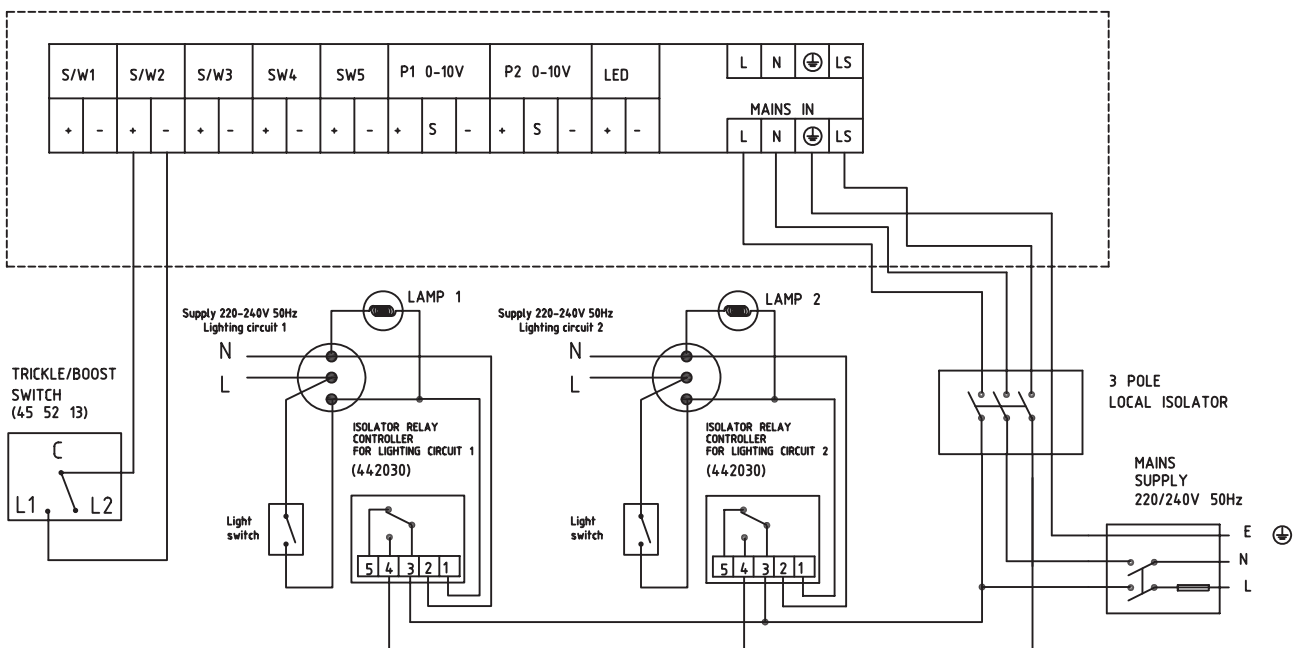



# Lo-Carbon Sentinel Kinetic<sup>®</sup> Cooker Hood

- Acoustic Top Box option for reduced in-duct noise
- Recognised in SAP PCDB
- Includes Cooker Hood Canopy
- Horizontal duct option for space-saving installations
- Fits within a 600mm wide aperture (300mm deep)
- Integrated digital controller for simple and accurate commissioning
- Plug and play controls; Humidistat
- BMS connectivity
- LS inputs (Light Switch)
- Volt-free inputs
- Self diagnosis for simplified fault finding
- Adjustable delay On/delay Off timer



## Easy Installation

Ducting can be attached to the unit horizontally, vertically or both. Minimum internal depth of kitchen cupboard: 300mm.

**Horizontal and Vertical Spigots:** The combination of spigot options allows installation in confined locations. If vertical and horizontal connection are required on the same outlet/inlet, additional spigots can be supplied.

The condensate connection can be taken through the rear of the unit or through the side of the unit into an adjacent cupboard prior to connection into pre-installed domestic waste water system.

## Cooker Hood Unit

The Sentinel Kinetic Cooker Hood is designed to fit in a 600mm wide aperture above a hob. The telescopic hood incorporates two flat removable metal grease filters, low energy light bulbs and is available with a White or Brushed Aluminium front trim.

The hood contains an integral fire damper in accordance with BRE Digest 398 and is connected to the heat recovery unit by a galvanised steel duct with access for cleaning. When the hood is opened, the heat recovery unit goes to boost speed and the summer bypass automatically opens to prevent cooking by-products entering the heat recovery cell. As an additional safety feature, the duct also contains a thermal cut-out fuse which turns off the MVHR unit in the event of excessive temperature in the airway. Cooker Hood units cannot be handed on-site and must be purchased as left hand (L) or right hand (R) models.

## SELV Models

SELV cooker hoods allow the distance between the hood and an electric hob to be reduced from 650mm to 550mm.

## Integral Humidity Sensor

The integral humidity (models with H suffix) sensor increases speed in proportion to relative humidity levels, saving energy and reducing noise. The sensor also reacts to small but rapid increases in humidity, even if

the normal trigger threshold is not reached. This unique feature ensures adequate ventilation, even for the smallest wet room. The night time relative humidity setback feature suppresses nuisance tripping as humidity gradually increases with falling temperature.

## Models

Lo-Carbon Sentinel Kinetic with summer bypass and humidity sensor.

Model	Stock Ref
Kinetic CWH L (White Left)	446756
Kinetic CSH L (Brushed Aluminium Left)	446757
Kinetic CWH R (White Right)	446758
Kinetic CSH R (Brushed Aluminium Right)	446759
Kinetic CWH L SELV (White Left)	477003
Kinetic CSH L SELV (Brushed Aluminium Left)	477004
Kinetic CWH R SELV (White Right)	477005
Kinetic CSH R SELV (Brushed Aluminium Right)	477006

## Accessories

Model	Stock Ref
Wired Remote Controller	443283
LED Alarm with 15m cable	448356
Opto-coupler for volt-free bms connection	447340
ISO 45% Coarse (G3) 2x Filter	442356
ISO ePM10 50% Pollen (M5) 1x Filter	444199
Grease 2x Filter	372774
Acoustic Purge Fan	477988
Acoustic Purge Fan XL	479829

## SAP PCDB Test Results

	SAP 2009		SAP 2012	
	Thermal Efficiency %	SFP (W/l/s)	Thermal Efficiency %	SFP (W/l/s)
K+1	85	0.72	85	0.78
K+2	85	0.74	85	0.89
K+3	84	0.83	82	1.03
K+4	83	0.92		

# SEC Class

Model	SEC Class
Kinetic CWH/CSH	A

## Performance

Fan speeds are fully adjustable within the performance range.

Horizontal Spigots

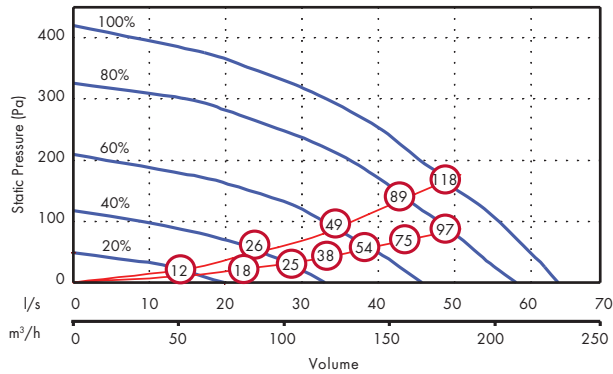

Vertical Spigots

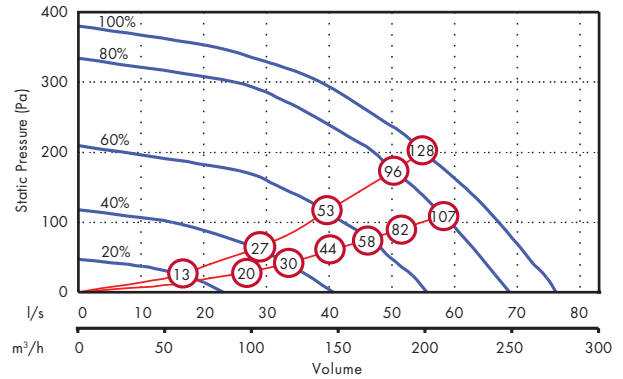

(x) figure relates to Wattage (both motors)

## Dimensions (mm)

Unit

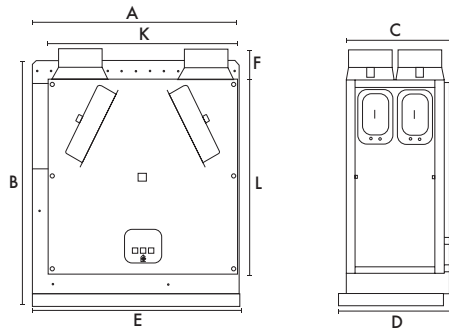

Minimum clearance from the bottom of this unit to the top of the hob must be:  
 Gas: 750mm  
 Electric: 650mm/ 550mm (SELV)

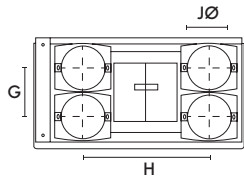

A	B	C	D	E	F	G	H	JØ	K	L	kg
590	710	295	316	598	90	140	360	125	550	550	27

## Sound Data

Flow l/s	Test mode	Octave band, Hz, dB SWL								SPL dB(A) @ 3m
		63	125	250	500	1K	2k	4K	8K	
10	Supply	47.8	40.2	38	31.1	28.2	22.1	23.6	30.9	21.4
	Extract	47	38.7	36	29.9	25	22.4	23.3	30.8	20.6
	Breakout	43.6	36.2	37.4	30.9	27.4	23.3	24.2	31.4	18.6
20	Supply	54	46.6	50.2	44.5	44.4	38.3	28.8	31.9	31.2
	Extract	46.8	40.5	34.6	34.2	34.6	25.9	23.7	30.3	22.9
	Breakout	45.9	39.9	40.6	35.7	33.5	28.4	25.3	31.2	21.3
30	Supply	58.1	54.5	57.6	52.2	51.7	47.6	38.6	35.8	38.5
	Extract	47.6	46.2	38.7	41.3	42.8	33.9	26.4	30.5	28.4
	Breakout	45.2	42.4	48.2	40.8	37.7	35.2	30	31.1	25.2
40	Supply	65.2	58.4	62.3	58	56.5	52.5	44.1	41.4	43.6
	Extract	53.5	53	44	47.7	48.1	39.7	31.5	31.5	33.5
	Breakout	50.9	47.6	47.4	48.1	42.5	40.8	36.3	34.4	29.3
50	Supply	66.4	63.2	66.3	62.5	61.7	57.4	50	47.8	48.3
	Extract	64.2	55.2	48	50.9	52.1	44.5	35.9	35	37.2
	Breakout	55	51	51.3	51.6	46.9	46.0	42	38.3	33.2

Tested according to BS EN 13141-7:2010. Breakout quoted spherical. Supply and Extract quoted hemispherical. For in-duct data, end reflections are added based on the spigot size of the unit.

## Consultant's Specification

### Operation

The supply and extract ventilation unit shall be a Sentinel Kinetic as manufactured by Vent-Axia and shall be sized as indicated on the drawings and shall be in accordance with the particular specification.

Supply air to the room shall be pre-heated by the extract air via the integrated composite plastic counterflow heat recovery cell. The Sentinel Kinetic shall automatically vary the ventilation rate via EC/DC motors, as it receives signals from one of the optional interconnected sensors. When a signal is received, the fans shall either vary their speed proportionally or on a trickle and boost principle.

The unit shall have the facility to commission the supply and extract fans individually via in-built minimum and maximum speed adjustment, or alternative wired remote control unit. The fans themselves shall have independent, infinitely variable speed control.

### Unit Specification

The unit shall be manufactured with an ABS outer case construction, and incorporate a metal duct to the cooker hood, intumescent fire damper and thermal switch, in accordance with BRE Digest 398.

The unit shall have a high efficiency composite plastic counterflow heat exchanger, supply and extract filters, automatic summer bypass, integral minimum and maximum infinitely variable speed controls with fascia mounted failure indication. The unit shall have low energy, high efficiency EC/DC fan/motor assemblies with sealed for life bearings. The impellers shall be high efficiency forward curved centrifugal type.

The unit shall have a heat exchanger cell with a thermal efficiency of up to 92% when tested to EN 308. This shall be protected by ISO 45% Coarse (G3) Filter 2pk grade synthetic filters on supply and extract. Complete with a condensate drip tray and drain connection.

The unit shall be constructed with a removable Core allowing full maintenance access. The removable Core shall provide access to the following:

- ✓ Supply and extract filter
- ✓ Heat exchanger
- ✓ Access to the electrical connections

Access shall be provided for wiring termination and setup/commissioning. The backlit LCD user interface therein shall be removable for remote mounting if required.

Units shall be as manufactured by Vent-Axia Ltd.

Sound tested to BS EN 13141-7:2010

### Standard Controls

All Sentinel Kinetic units shall incorporate the following functions integrally mounted, pre-wired and factory fitted by the manufacturer:

- ✓ Integral infinitely variable fan speed control on supply and extract
- ✓ Integral min/max ventilation control/set point
- ✓ Integral BMS interfaces - control and status indication
- ✓ Heating interlocks
- ✓ 0-10V proportional speed adjustment
- ✓ Volt free contacts
- ✓ 24V sensor supply
- ✓ Integral on/off or trickle boost function from remote switch e.g. PIR occupancy detector
- ✓ The unit shall be controlled by the 'Sentinel' control devices (enablers and sensors) as detailed in the schedule or on the drawings
- ✓ Fully automatic summer bypass
- ✓ Switched Live input with adjustable 'Delay-On' feature

- ✓ Fan failure or component failure indicated via individual fault code display
- ✓ Running time counter
- ✓ Control panel PIN number lock
- ✓ Automatic frost protection effective to -20°C
- ✓ Tool free filter access
- ✓ The unit shall incorporate ('H' models) an integral humidity sensor with the following features:
  - Ambient Response; Raises the humidity trigger point as dwelling temperature reduces
  - Rapid Response; Monitors the rate of change in humidity and triggers increased airflow even if the humidity trigger threshold is not reached
  - Proportional Response; Incrementally increases the fan speed to reduce noise and reduce energy consumption

### Integral Cooker Hood Specification

The Sentinel Kinetic Cooker Hood shall consist of a telescopic Hood and galvanised steel duct connection to the MVHR Unit.

The Hood construction shall be of grey powder coated steel with Brushed Aluminium or White painted fascia.

The Hood shall trigger the MVHR unit to a pre-defined boost speed and open the summer bypass when opened, and shall have two low-energy lamps illuminating the hob top.

Filter shall be a flat metal grease filter, removable for cleaning.

The galvanised steel ductwork shall provide a continuous fire barrier between the Hood and the MVHR unit. It shall contain an Intumescent fire damper, thermal cut-out and volume balancing damper. The thermal cut-out shall switch off the MVHR unit at a pre-defined safety temperature.

The duct shall have an access panel for cleaning by the end-user.

### Mounting Option



Wall

## Airflow Direction

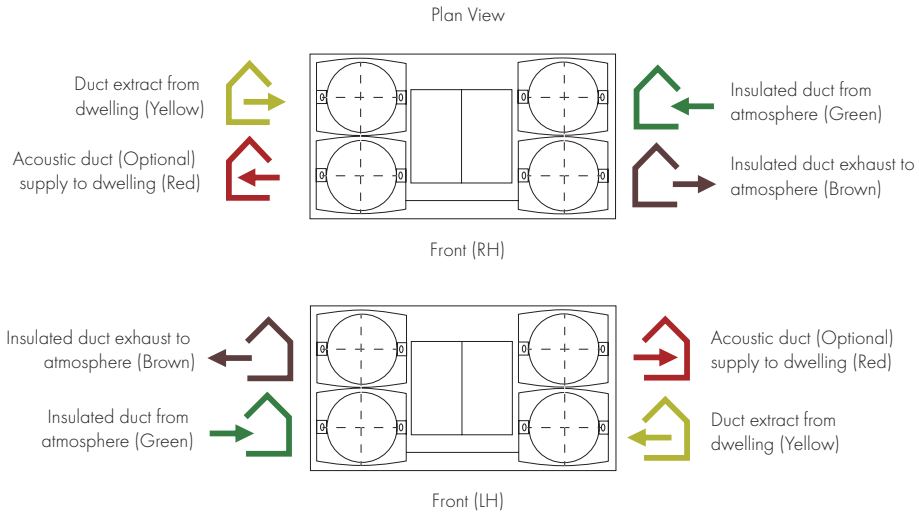

## Electrical Connection

Please note: Electrical connection should be carried out by an appropriately qualified person and in accordance with current wiring regulations.

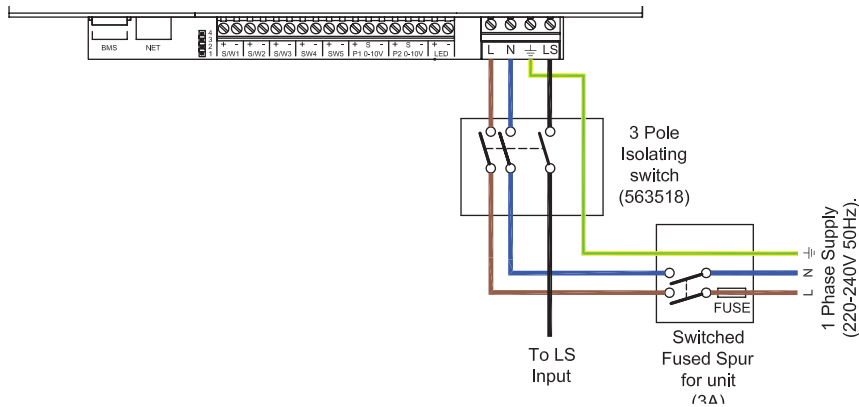

## Trickle to Boost by a Light Circuit

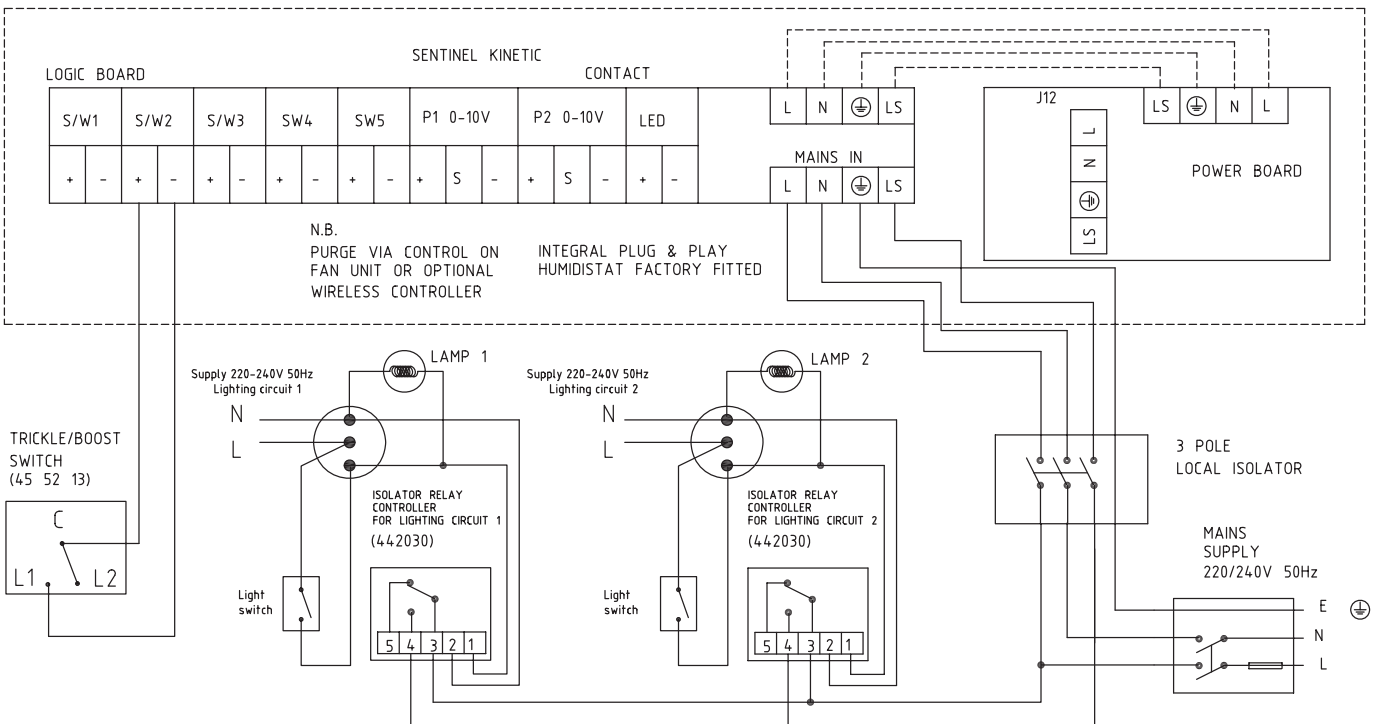

# Lo-Carbon Sentinel Kinetic<sup>®</sup> Horizontal

- Manufactured in the UK
- Building Regulations ADF compliant
- Recognised in SAP PCDB
- Energy Savings Trust best practice compliant
- Up to 81% heat recovery whilst controlling condensation
- Programmable Summer bypass
- Digital controller for simple and accurate commissioning
- External condensate connection
- Plug and play controls; Humidistat
- LS inputs (Light Switch)
- Volt-free inputs
- Self diagnosis for simplified fault finding
- Adjustable delay On/delay Off timer

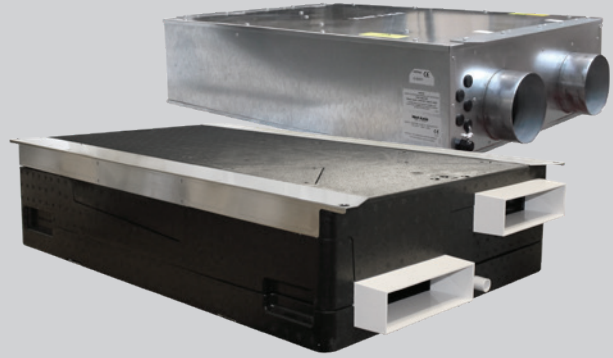

## The Sentinel Kinetic Horizontal Range

A wholehouse heat recovery system with up to 81% heat exchange efficiency. An easily accessible heat recovery cube protected by two removable ISO 45% Coarse (G3) Filter 2pk. Two Lo-Carbon Energy Saving EC/DC fans ensure long life (typically over double the life of AC motors) and lowest possible energy use. Fully insulated construction with built-in condensation drain. Specifically designed for new build constructions with a high level of insulation.

Lo-Carbon Sentinel Kinetic Horizontal meets the latest requirements of the Building Regulations ADF for wholehouse system ventilation: Continuous mechanical supply and extract with heat recovery. Each model has three fully adjustable speeds and a purge setting (maximum flow). Supplied with the unit is a digital controller that can be used to pre-set the speeds to any required airflow within the performance range.

## Integral Humidity Sensor

The integral humidity sensor ('H' models) increases speed in proportion to relative humidity levels, saving energy and reducing noise. The sensor also reacts to small but rapid increases in humidity, even if the normal trigger threshold is not reached. This unique feature ensures adequate ventilation, even for the smallest wet room. The night time relative humidity setback feature suppresses nuisance tripping as humidity gradually increases with falling temperature. Acoustically lined - low noise levels from only 20dB(A) @ 3m.

## Models

Model	Stock Ref
Kinetic 200ZPH	407162
Kinetic 200ZH	449540A
Kinetic 200ZMH	448778A
Kinetic 300ZH	449536A

## Accessories

Model	Stock Ref
200ZPH 45% Coarse (G3) 2x Filter	407584
200ZH/ZMH 45% Coarse (G3) 2x Filter	449524

200ZH/ZMH ePM10 50% Pollen (M5) 1x Filter	404574
300ZH 45% Coarse (G3) 2x Filter	449575
300ZH ePM10 50% Pollen (M5) 1x Filter	404575
Acoustic Purge Fan	477988
Acoustic Purge Fan XL	479829

## Multiple Control Options:

Five Volt-free pairs of switch terminals for sensor inputs allow boosting from a full range of Vent-Axia controllers - humidistats, PIR, timers.

Two terminals with 0-24V outputs allow 0V to 10V proportional control by sophisticated controllers such as CO<sub>2</sub> sensors and proportional humidistats.

Switch-live for boosting via light switches (220-240V AC) or manual Normal/Boost switches. This connection has the advantage of Delay-On and Delay-Off facility. Delay-On enables you to prevent the Boost airflow between 0 and 10 minutes after a light switch has been activated. Delay-Off allows the Boost airflow to continue after a light switch is turned off to ensure effective clearance of humidity. This timer is adjustable between 0 and 25 minutes.

## Summer Bypass

An internal damper operates when the external temperature is below the internal temperature, and the internal temperature is too high.

The bypass opens and allows the cooler outside air to help cool the dwelling.

Normal mode: Fans run on Normal speed with bypass open until the internal dwelling temperature falls below the set 'Indoor' (maximum desired) temperature.

Evening Purge mode: The fans run on Boost speed until the internal temperature falls below the set 'Indoor' temperature. If, after five hours the internal temperature is still above the set 'Indoor' temperature, the unit will switch down to normal speed for the remainder of the 'bypass open' period.

Nighttime Purge mode: As Evening Purge, except that the unit will continue on Boost speed until the internal air temperature reaches the 'Outdoor' temperature set point (Default 14°C). This mode gives pre-cooling of the dwelling for the following day.

In Evening and Night Time Purge modes, the user can turn off the boost function by pressing the Boost button.

### Frost Protection

In cold climates there is a possibility of frost building up on the intake side of the heat exchanger. In order to prevent damage, the Kinetic reduces supply flow while maintaining extract flow at temperatures down to -20°C.

### SEC Class

Model	SEC Class
Kinetic 200ZH/ZPH/ZMH	A
Kinetic 300ZH	A

### SAP PCDB Test Results

200ZPH	SAP 2009		SAP 2012	
	Thermal Efficiency %	SFP (W/l/s)	Thermal Efficiency %	SFP (W/l/s)
K+1	86	0.62	84	0.67
K+2	84	0.65	82	0.82
K+3	83	0.76	80	1.07

200ZH/ZMH	SAP 2009		SAP 2012	
	Thermal Efficiency %	SFP (W/l/s)	Thermal Efficiency %	SFP (W/l/s)
K+1	80	0.69	81	0.73
K+2	81	0.70	81	0.89
K+3	80	0.80	79	1.12
K+4	80	0.97	78	1.39
K+5	79	1.14		

300ZH	SAP 2009		SAP 2012	
	Thermal Efficiency %	SFP (W/l/s)	Thermal Efficiency %	SFP (W/l/s)
K+1	77	0.59	78	0.54
K+2	78	0.51	78	0.61
K+3	78	0.57	78	0.75
K+4	78	0.66	78	0.93
K+5	78	0.76	77	1.13
K+6	78	0.88	76	1.35
K+7	77	1.05		

### Dimensions (mm)

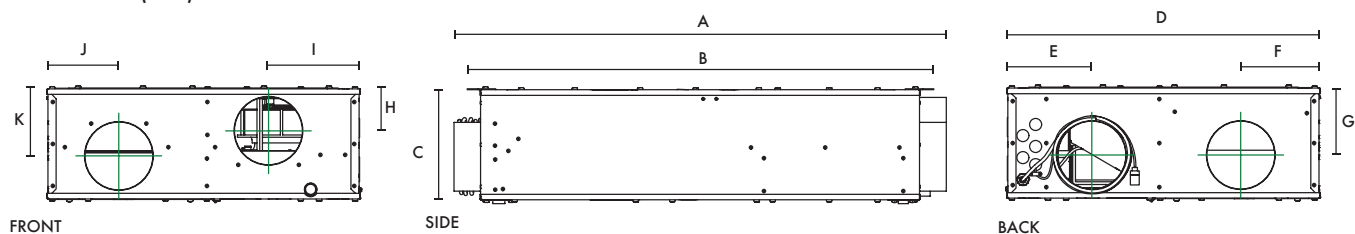

Model	A	B	C	D	E	F	G	H	I	J	K	Spigots Ø
200ZH	895	849	200	570	155	144	122	76	167	131	122	125
300ZH	985	940	301	720	184	179	187	102	279	174	187	150

Weight: 200ZH - 26kg, 300ZH - 38kg

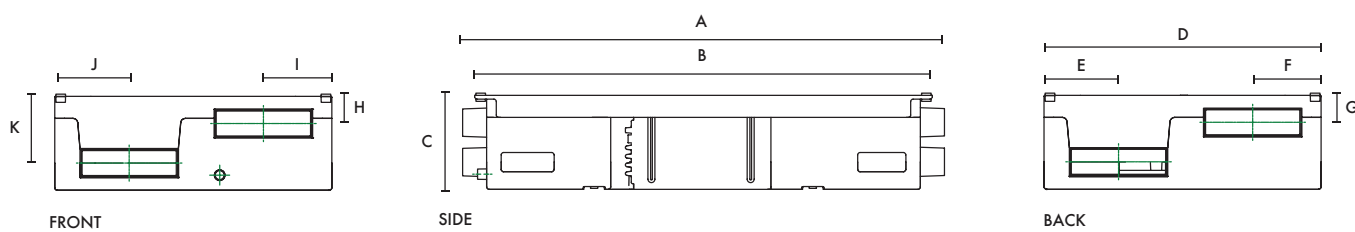

Model	A	B	C	D	E	F	G	H	I	J	K	Spigots
200ZPH	1000	950	200	575	155	142	60	61	142	154	143	204x60
200ZMH*	895	849	200	570	195	140	54	66	168	138	143	204x60

Weight: 200ZPH - 14kg, 200ZMH - 26kg

\*Galvanized steel outer case construction

## Performance - 200ZH/ZMH/ZPH Model

Fan speeds are fully adjustable within the performance range.

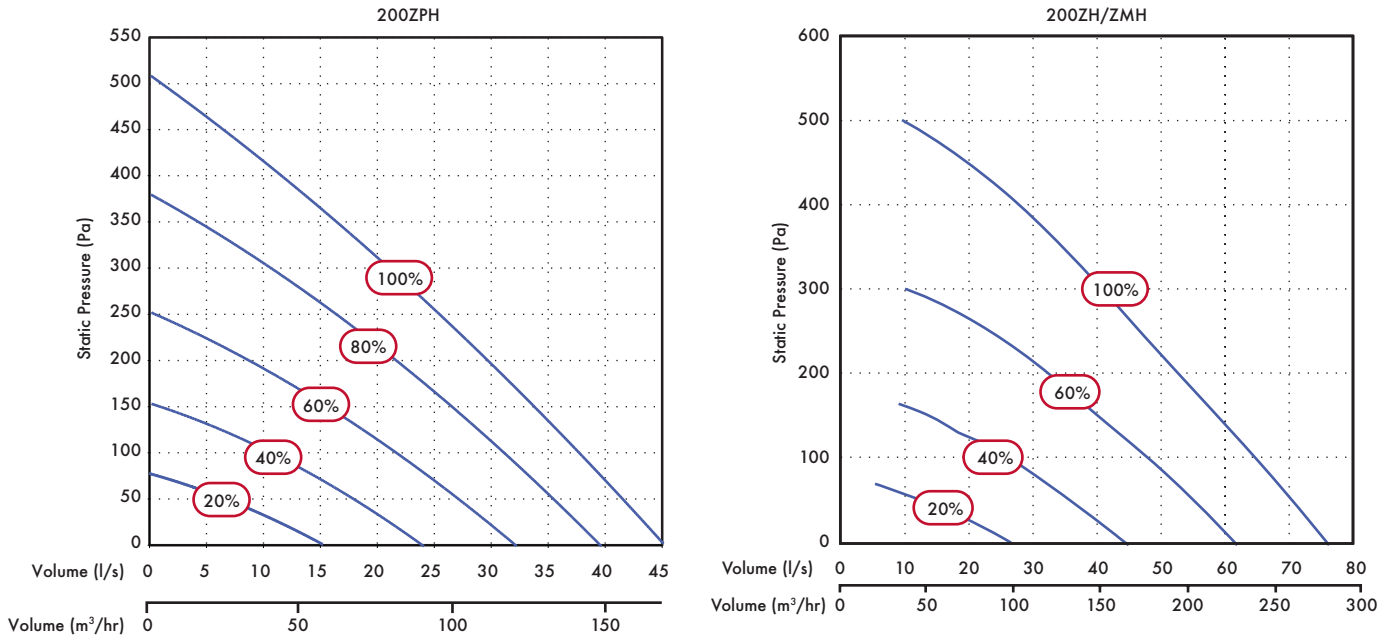

### Sound Data - 200ZPH Model

Speed	Test mode	63	125	250	500	1k	2k	4k	8k	dB(A) at 3m
20%	Breakout	48.3	41.3	37.7	35.8	34.5	28.2	26	31.2	21.5
	Supply	39.6	37.1	36	32.9	30.6	22.9	24.9	29.4	23.1
	Extract	49.4	40.7	35	30.4	26.3	22.5	23.6	30.1	20.8
40%	Breakout	47.8	42.2	46.7	40.6	40.2	34.2	28.1	31.2	25.3
	Supply	45.7	38.3	40.7	39	38.1	28.7	24.9	28.5	28.1
60%	Extract	50	45.5	39.9	37	34.3	28.6	25.1	30.6	24.3
	Breakout	54.4	51.2	53.8	46.2	43	38.9	33.8	32	29.7
	Supply	46.1	49.2	45.3	44.4	42.4	35.2	27	29.3	32.7
80%	Extract	49.5	41.9	45.4	41.7	39.4	35.2	27.6	30.3	27.7
	Breakout	50.4	51.2	56.7	53.9	48.5	43.2	39.9	34.9	34.5
	Supply	52.9	48.9	47.5	51.3	47.2	40.8	31.2	30	36.8
100%	Extract	48.9	43.3	46.8	50	42.4	38.6	31.3	30.1	32.2
	Breakout	49.3	49.8	52.9	54	51	46.3	41.2	35.7	35.1
	Supply	43.8	45.8	50.7	56.3	50	44.3	35.7	29.7	38.2
	Extract	53.2	46.9	48	52.8	45.4	42.1	35.1	30.5	34.9

### Sound Data - 200ZH/ZMH Model

Flow %	Test mode	63	125	250	500	1k	2k	4k	8k	dB(A) at 3m
20	Supply	50.3	54	50.1	45.5	37	36	27.5	31.1	30.0
	Extract	47.2	47.7	46.6	41.8	30.7	27.9	24.6	30.5	26.3
	Breakout	48.8	55.8	51.2	43.8	32.4	29.0	25.4	30.8	26.8
40	Supply	52.7	61.7	60.1	61.8	47.4	45.1	38.1	40.1	42.7
	Extract	50.7	55.4	55.0	51.5	37.5	34.6	25.9	30.7	33.9
	Breakout	53.7	60.1	61.1	50.7	40.2	35.8	27.1	30.3	34.0
60	Supply	52.8	64.5	66.7	59.4	51.1	51.1	42.9	39.3	44.0
	Extract	50.6	59.0	62.1	57.1	43.7	40.0	29.0	31.6	39.7
	Breakout	55.1	64.4	66.8	57.5	47.0	41.4	32.0	32.0	39.7
100	Supply	58.3	69.2	68.6	64.6	56.9	56.1	47.9	45.6	48.1
	Extract	51.8	63.1	64.9	63.9	52.4	45.9	34.8	34.8	45.2
	Breakout	59.4	68.1	69.7	68.3	53.1	47.1	36.5	34.3	46.5

Tested according to BS 848. Breakout quoted spherical. Supply and extract quoted hemispherical.



## Performance - 300ZH Model

Fan speeds are fully adjustable within the performance range.

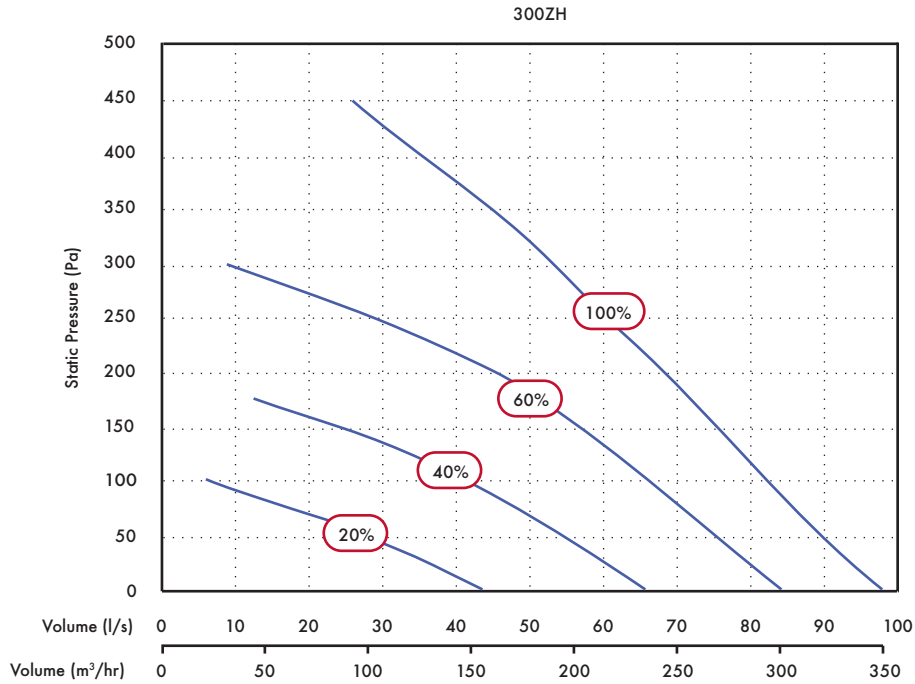

## Sound Data - 300ZH Model

Flow l/s	Flow %	Test mode	63	125	250	500	1k	2k	4k	8k	dB(A) at 3m
26	10	Supply	42.5	42.8	38.3	32.9	28	24.6	25.5	30.3	26.3
		Extract	46.9	45	40.3	34.4	27.4	23	24.3	30.1	22.5
		Breakout	48.7	52.1	47.7	40.5	32.9	27.3	25.1	31.6	24.4
44	20	Supply	45.6	47	41.7	35.7	31.7	26.7	24.8	30	29.9
		Extract	46.9	48.6	47	38.2	29.5	25.3	23.8	29.9	25.3
		Breakout	50.2	56.4	53.9	46.3	37.5	32.5	25.2	31.4	28.8
55	30	Supply	44.4	46	52.9	39.4	35.1	31.9	25.5	30.5	33.9
		Extract	47	48	55.5	42.5	32.2	29.9	25.7	30.6	30.6
		Breakout	52.2	59.6	62	51.4	41.9	37.4	28.1	31.4	34.7
66	40	Supply	43.1	44.4	54.3	43.5	39.2	35.7	27.7	29.9	35.0
		Extract	48.9	49	58.4	45.9	35.7	33.4	25.3	29.9	33.4
		Breakout	54.6	58.3	66.1	52.6	39.3	36.5	31.1	35.3	37.7
85	60	Supply	44.7	49.8	58	50.4	45	41.9	30.6	30.3	39.1
		Extract	51	53.6	61.2	50.1	41.6	40.1	30.7	31.1	36.7
		Breakout	57.5	62.6	68.7	57.5	45.9	41	36.3	34	40.7
96	80	Supply	46	52.2	57.1	56.5	47.2	44.2	32.3	30.5	40.5
		Extract	55.5	55	63.1	53.4	44.3	41	33.5	31.4	38.8
		Breakout	62.2	65.7	68.8	63	50.8	43.8	38.8	35.4	42.9
98	100	Supply	46.6	52.3	57	55.4	47.1	43.7	32.1	30.3	40.1
		Extract	53.7	55.2	63.3	53.3	44.1	41.2	33.2	31.5	38.9
		Breakout	62.2	73.8	77.4	74.1	67.4	61	53.6	45.4	53.9

Tested according to BS848. Breakout quoted spherical. Supply and Extract quoted hemispherical.

## Consultant's Specification

### Operation

The supply and extract ventilation unit shall be as Sentinel Kinetic Z as manufactured by Vent-Axia and shall be sized as indicated on the drawings and shall be in accordance with the particular specification; 200Z - 200mm deep, 300Z - 300mm deep.

The Sentinel Kinetic Z shall automatically vary the ventilation rate via EC/DC motors, as it receives signals from one of the optional interconnected sensors. When a signal is received, the fans shall either vary their speed proportionally or on a trickle and boost principle.

The unit shall have the facility to commission the supply and extract fans individually via the wired remote control unit. The fans themselves shall have independent, infinitely variable speed control.

### Unit Specification (200Z/ZM, 300ZH)

The unit shall be manufactured with a galvanized steel outer case construction and shall have a high efficiency aluminium heat exchanger.

### Unit Specification (200ZP)

The unit shall be manufactured with high density EPP case and shall have a high efficiency polymer heat exchanger.

The unit shall have supply and extract filters, automatic summer bypass, integral minimum and maximum infinitely variable speed controls with failure indication via the wired remote controller.

The unit shall have low energy, high efficiency EC/DC fan/motor assemblies with sealed for life bearings. The impellers shall be high efficiency backward curved centrifugal type.

The unit shall have a heat exchanger cell with a thermal efficiency of up to 81% when tested to EN 308. This shall be protected by ISO 45% Coarse (G3) Filter 2pk grade synthetic filters on supply and extract. Complete with a condensate drip tray and drain connection.

The unit shall be constructed with a removable access panel allowing full maintenance access from below. The removable panel shall provide access to the following:

- ✓ Supply or extract fan
- ✓ Supply and extract filter
- ✓ Heat exchanger
- ✓ Access to the electrical connections

Access shall be provided for wiring termination and setup/commissioning.

Sound tested to BS EN 13141-7:2010

### Standard Controls

All Sentinel Kinetic Z units shall incorporate the following functions integrally mounted, pre-wired and factory fitted by the manufacturer:

- ✓ Infinitely variable fan speed control on supply and extract
- ✓ Min/max ventilation control/set point
- ✓ Heating interlocks
- ✓ 0-10V proportional speed adjustment
- ✓ Volt free contacts
- ✓ 24V sensor supply
- ✓ On/off or trickle boost function from remote switch, e.g. PIR occupancy detector
- ✓ The unit shall be controlled by the 'Sentinel' control devices (enablers and sensors) as detailed in the schedule or on the drawings

- ✓ Fully automatic summer bypass
- ✓ Switched Live input with adjustable 'delay-on' feature
- ✓ Fan failure or component failure indicated via individual fault code display
- ✓ Running time counter
- ✓ Control panel PIN number lock
- ✓ Automatic frost protection effective to -20°C
- ✓ The unit shall incorporate ('H' models) an integral humidity sensor with the following features:
  - Ambient Response: Raises the humidity trigger point as dwelling temperature reduces
  - Rapid Response: Monitors the rate of change in humidity and triggers increased airflow even if the humidity trigger threshold is not reached
  - Proportional Response: Incrementally increases the fan speed to reduce noise and reduce energy consumption

The unit shall be controlled by the 'Sentinel' control devices (enablers and sensors) as detailed in the schedule or on the drawings.

## Mounting Option



Slab

## Airflow Direction

View from beneath (drawing for airflow demonstration only - not intended to be an accurate representation of the product)

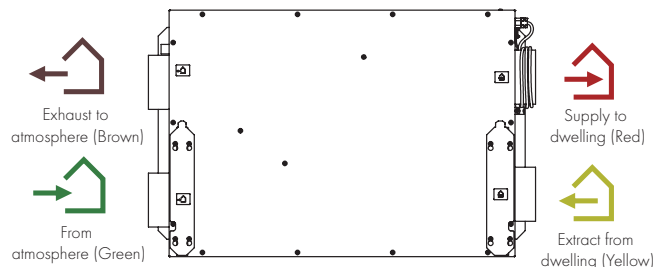

## Electrical Connection

Please note: Electrical connection should be carried out by an appropriately qualified person and in accordance with current wiring regulations.

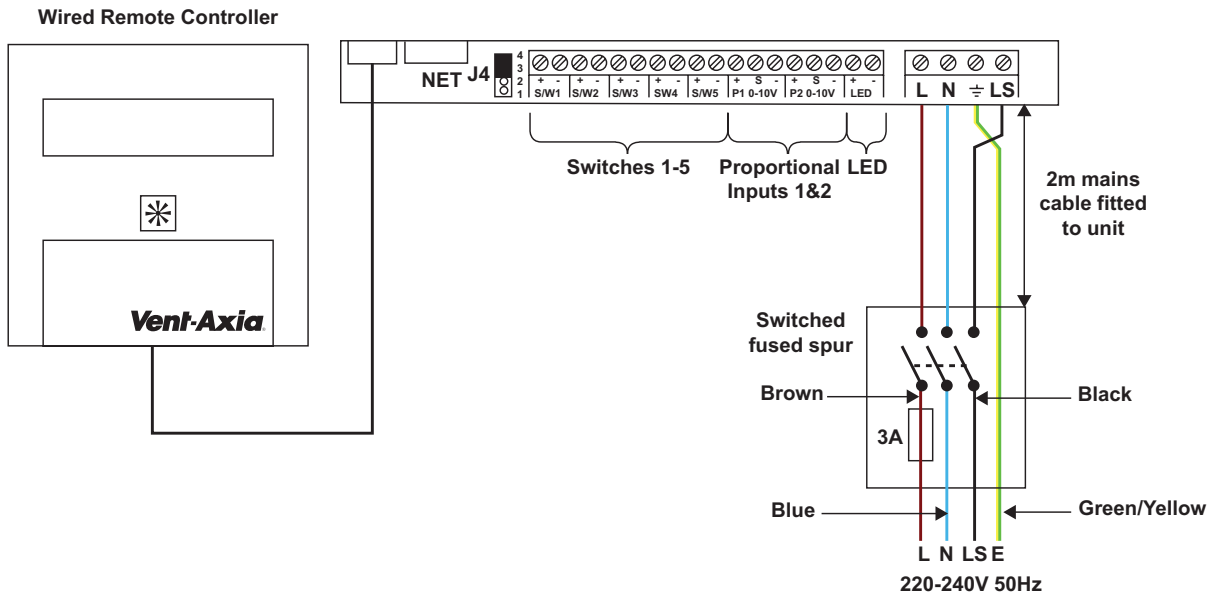

## Trickle to Boost by two lighting circuits or Trickle/Boost Switch

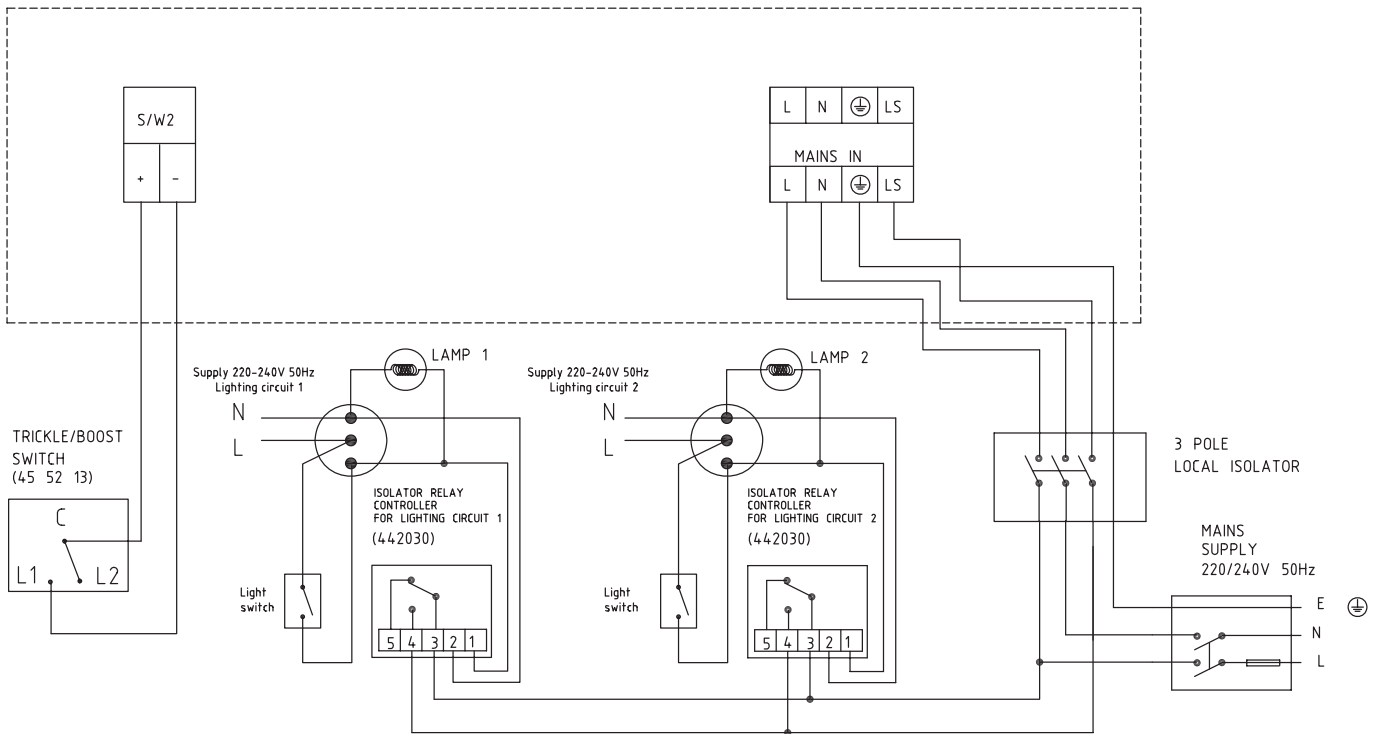

# Integra

- Up to 70% heat recovery
- Low power consumption
- Effective condensation control
- Summer mode



The Integra heat recovery unit has been specially designed to provide ventilation for flats or rooms in residential, commercial, educational or leisure applications. Balanced ventilation is achieved by using nominal 100mm diameter rigid ducting.

Using a high performance, polymeric heat exchange cube, together with two powerful fans, the Vent-Axia Integra achieves efficiencies of up to 70%.

The compact cube interleaves outgoing moist air with incoming fresh air, allowing the heat from one to warm the other without the two air streams mixing. Energy is saved on room heating, with no power being used by the cube itself.

Performance of Integra: Up to 49l/s FID. Ideal for installation in ceilings voids or cupboards.

The 150VA Transformer enables the selection of trickle settings to match dwelling volume.

## Models

Model	Stock Ref
Integra	456864

## Controller

Model	Stock Ref
Controller 150VA	563538

## Airflow Direction

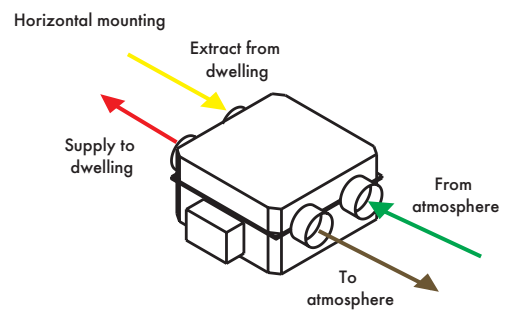

## SEC Class

Model	SEC Class	SEC Class (inc. LDC)
Integra	F	C

## Dimensions (mm)

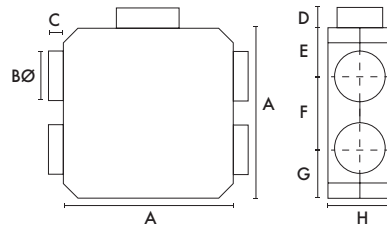

A	BØ	C	D	E	F	G	H
400	98	50	65	85	230	85	210

Weight: 6.5kg

## Performance

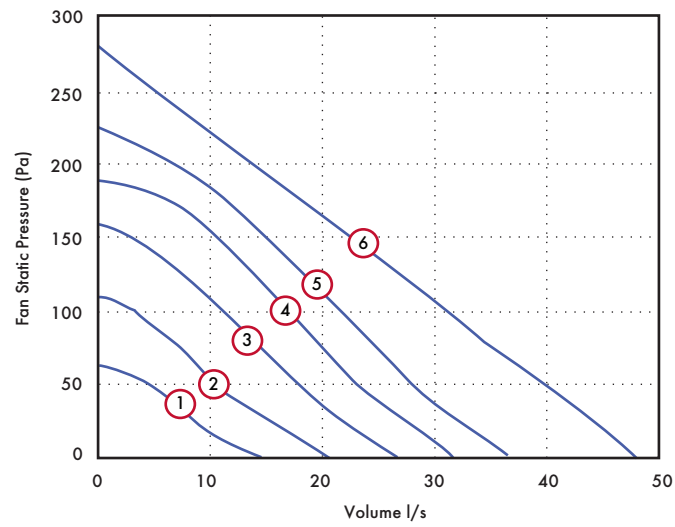

Motor Speed/Curve	Volume (l/s) (FID)	Voltage (V)	Wattage (W)
1	15	80	32
2	21	100	47
3	27	120	64
4	32	140	81
5	37	160	99
6	49	240	182

Integra to be used with a 150VA Transformer for maximum controllability.

# Integra Plus EC

- Up to 70% heat recovery
- Low power consumption
- Effective condensation control
- 3 speed control
- Summer mode
- EC motors



## Easy Installation

The Vent-Axia Integra Plus EC is designed for mounting in ceiling voids, lofts and above a suspended ceiling. Four 150mm spigots are provided for simple connection to insulated flexible or rigid ventilation ducting. The unit comes complete with a 22mm condensate outlet.

The Integra Plus EC incorporates two adjustable speeds and a Purge setting (full Speed).

Switching on the controller allows activation of the Summer Mode.

## Model

Model	Stock Ref
Integra Plus EC	437666EC

## SEC Class

Model	SEC Class	SEC Class (inc. LDC)
Integra Plus EC	B	A

## Airflow Direction

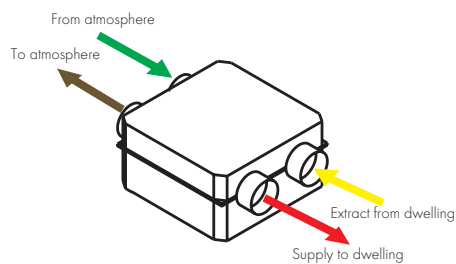

## Controllers & Sensors

Model	Stock Ref
Ambient Response Humidistat	563550A
Visionex PIR	459623B

## Dimensions (mm)

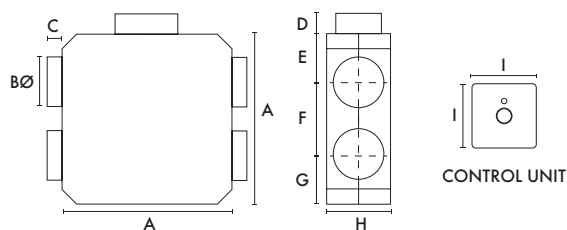

A	ØB	C	D	E	F	G	H	I
580	150	100	64	125	350	125	305	85

Weight: 17kg fan box

## Performance

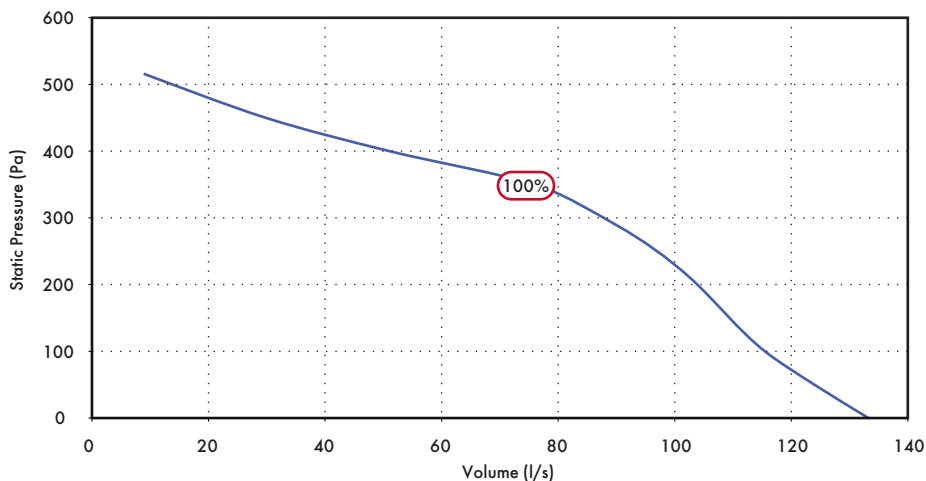

## Sound Data

Flow, l/s	Unit setting V	Test mode	Octave band, Hz, dB SWL								SPL dB(A) at 3m
			63	125	250	500	1k	2k	4k	8k	
55	4	Supply	39.2	43.1	44.5	47.1	42.6	36.0	29.3	30.7	30.7
		Extract	47.0	42.4	38.6	40.4	35.5	28.0	27.9	32.6	25.3
		Breakout	43.2	42.7	38.2	37.6	33.4	28.4	27.6	31.5	21.7
69	5	Supply	42.0	47.6	46.1	49.9	48.8	41.2	33.7	32.5	34.4
		Extract	47.8	42.2	41.4	43.2	40.4	29.6	27.7	32.5	27.7
		Breakout	45.2	45.7	41.9	40.7	37.3	30.5	27.5	32.4	23.8
79	6	Supply	46.0	49.7	50.6	54.0	54.4	45.9	39.6	36.9	38.7
		Extract	44.5	43.2	44.8	46.4	46.2	32.2	28.4	32.3	31.4
		Breakout	46.2	47.2	44.3	43.4	43.1	32.8	28.5	32.2	26.6
81	6.6	Supply	47.0	52.5	53.8	56.4	58.3	48.8	42.8	40.8	41.8
		Extract	50.3	45.3	47.7	48.5	47.4	35.0	30.7	32.9	33.0
		Breakout	45.5	47.9	45.5	45.5	45.5	34.0	29.2	31.5	28.3
95	7	Supply	48.9	54.1	56.3	58.0	59.2	51.0	45.9	43.8	43.3
		Extract	47.6	46.5	49.4	49.7	48.3	37.0	31.1	32.3	34.0
		Breakout	49.0	49.5	48.2	47.5	47.3	36.7	31.1	32.3	30.1
109	8	Supply	51.0	58.2	57.4	60.1	61.2	54.4	48.9	48.0	45.6
		Extract	56.2	52.4	51.7	53.1	49.6	39.5	33.8	33.2	36.3
		Breakout	51.8	53.9	51.3	50.7	48.7	40.3	34.0	32.5	32.2
113	9	Supply	49.1	56.1	59.4	62.8	63.3	57.2	52.1	50.8	47.4
		Extract	54.5	50.9	52.4	54.5	51.4	42.3	35.3	33.8	37.8
		Breakout	53.6	54.3	52.8	52.3	50.8	43.4	36.2	33.5	34.1

Tested according to BS848. Breakout quoted spherical. Supply and Extract quoted hemispherical.



# HR100R/RS

- Controls condensation and odours
- Eliminates mould growth
- Up to 70% heat recovery - saves energy
- Extremely quiet operation
- Two speed settings
- ERP exempt (<30W)



The HR100R and HR100RS are ideal for single bedrooms/bathroom applications situated in hotel rooms, nursing homes and residential care homes.

The HR100R features top access making it ideal for loft installations.

The HR100RS features bottom access for installation on the slab above a suspended ceiling.

The HR100R/RS is a self-contained heat recovery unit for mounting in lofts and suspended ceilings. The unit is supplied without controls to allow for the unit to be tailored to suit the individual requirements.

Compatible with standard 100mm ducting for connection to internal grilles and external cowl.

The unit comes fitted with a single 2-speed motor, and provides continuous low volume ventilation with a boost option. A variety of control devices are available for manual or automatic speed control.

An integral heat exchanger transfers heat from the outgoing stale air to the fresh air supply, raising the supply air temperature whilst at the same time reducing its relative humidity.

Up to 18l/s FID capacity. The unit provides superior control of condensation and odours, ideal for bathrooms or small internal rooms.

## Models

### HR100R

Top access - ideal in loft installations.

Model	Stock Ref
HR100R	370377

### HR100RS

Bottom access - ideal for suspended ceilings.

Model	Stock Ref
HR100RS	435004

## Controllers

### Normal Boost Switch

A single gang switch to boost from high to low speeds on all heat recovery systems.

85 x 85 x 10mm (H x W x D)

Model	Stock Ref
Normal Boost Switch	455213

## HR100RS Version

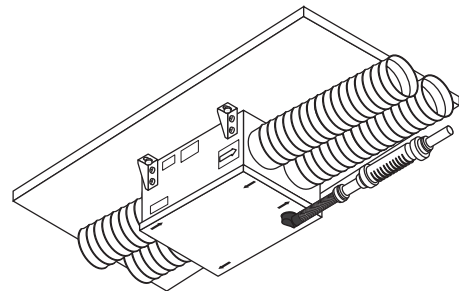

## Dimensions (mm)

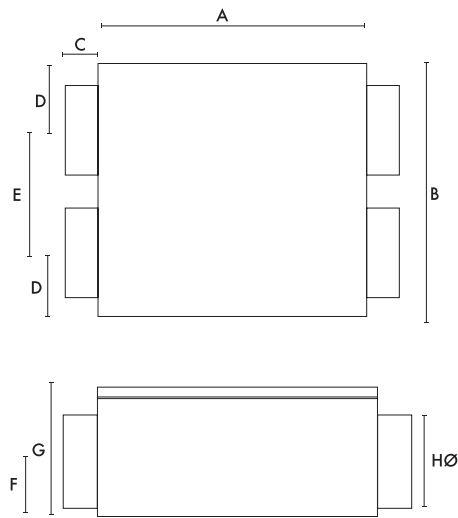

A	B	C	D	E	F	G	HØ
305	240	50	60	120	70	160	98

## Performance

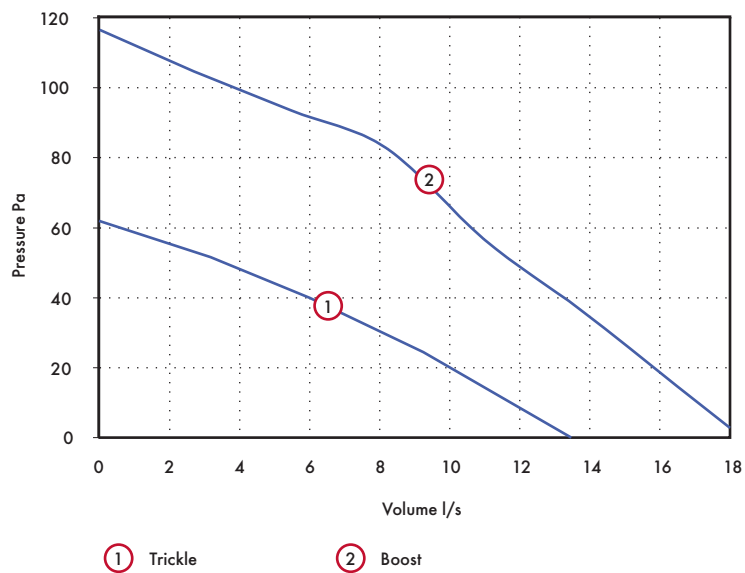

Model	Weight kg	Extract Perf. l/s		Watts		dB(A) @ 3m*	
		Boost	Trickle	Boost	Trickle	Boost	Trickle
HR100R	5.6	18.3	13.6	29	19	30	20
HR100RS	5.6	18.3	13.6	29	19	30	20

Mains electrical supply: 230V/50Hz

# HR500

- Efficient 550m<sup>3</sup>/h heat recovery ventilation unit or high performance 900m<sup>3</sup>/h extract fan
- Lightweight, compact and easy to install
- Integral shutters on X type model
- Easy to clean
- Up to 70% heat recovery
- Controller with sensor mode, allows a range of sensors to be used in conjunction with the HR500 and HR500X units
- IPX5 rated



## Heat Recovery Ventilation

HR500 heat recovery ventilation units for through the wall installation, which exhaust stale air whilst introducing warmed fresh air from the outside.

Ideal for computer rooms, classrooms, offices and the health and leisure industries. The Vent-Axia HR500 unit is the perfect solution for commercial areas that require a high performance balanced intake/extract ventilation scheme. As a heat recovery ventilation unit it moves a useful 153l/s of air.

The compact heat recovery cube interleaves outgoing warm air with incoming fresh air and allows the heat from one to warm the other without the two air streams mixing. Energy is saved on room heating with no power being used by the cube itself.

The HR500 and HR500X consist of a tough telescopic wall sleeve into which the main body of the unit is housed. Walls of up to 670mm thick can be easily accommodated. Behind the neat deflecting fascia grilles are the filters, the heat exchange cube and fan units. All wall sleeve components, the heat exchange cube and the fascia grilles are made of tough polymeric materials.

## Electrical

Maximum ambient temperature +40°C.  
Supply Voltage 220-240V/1/50Hz.

## Models

### HR500 Commercial

Wall-mounted intake/extract ventilation unit with built-in heat recovery facility. For commercial and leisure areas. Lightweight, compact and easy to install.

<b>Model</b>	<b>Stock Ref</b>
HR500	14101010B

### HR500X

As HR500 with shutters.

<b>Model</b>	<b>Stock Ref</b>
HR500X	14101070

## Controller

### HR500 Controller

Surface mounting. On/Off remote sensor mode. Heat exchange, single fan extract or twin fan extract modes. Infinitely variable speed. Minimum speed setting. Suitable for controlling up to 2x HR500. 86 x 156 x 53 (W x H x D).

<b>Model</b>	<b>Stock Ref</b>
HR500 Controller	W14301010

## Dimensions (mm)

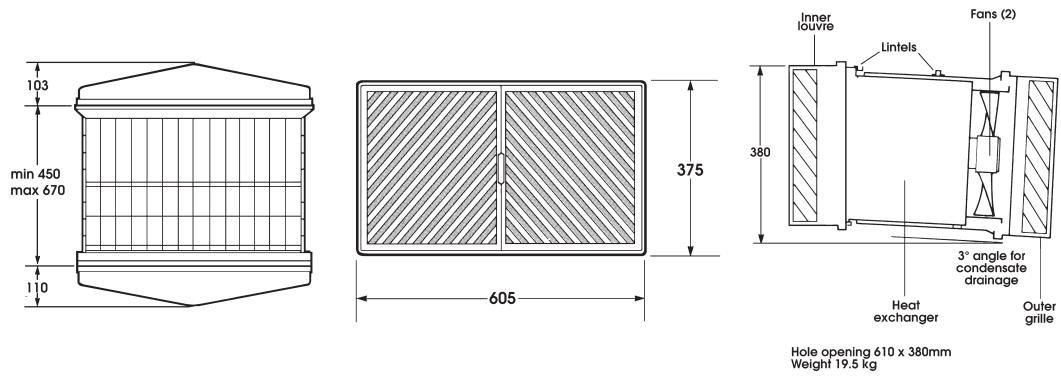

## Performance

Model	Airflow performance (l/s)		Watts (max)	Sound dB(A) @ 3m (max)
	Heat recovery mode	Extract mode (max)		
HR500	153l/s	250l/s	200	53
HR500X	153l/s	250l/s	220	53

# HR500D

- Self-contained unit with integral fans
- Up to 70% heat recovery
- External wall mounting



The HR500D is a self-contained unit with integral extract and supply fans to provide balanced ventilation and heat recovery via supply diffusers and extraction grilles. The unit is fully speed controllable.

The compact heat recovery cube interleaves outgoing warm air with incoming fresh air and allows the heat from one to warm the other without the two air streams mixing.

Energy is saved on room heating with no power being used by the cube itself.

Performance of HR500D: Supply and extract up to 174l/s FID capacity on heat recovery mode. Ideal for offices, computer rooms, pubs and clubs, etc.

---

## Model

Surface mounting. On/Off remote sensor mode. Heat exchange, single fan extract or twin fan extract modes. Infinitely variable speed. Minimum speed setting. Suitable for controlling up to 2x HR500.

Model	Stock Ref
HR500D	370450

---

## Controller

Model	Stock Ref
Speed Controller	W14301010

---

## Dimensions (mm)

Hole opening: 610 x 381mm

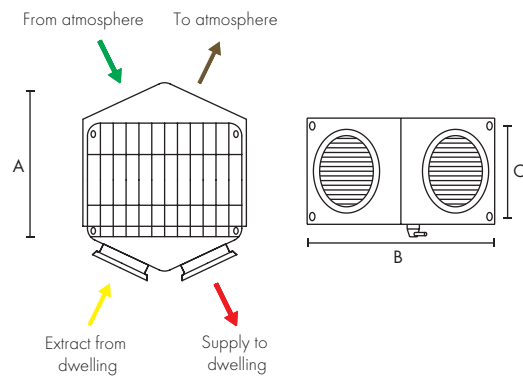

A	B	C
480-750	600	340

## Performance Guide

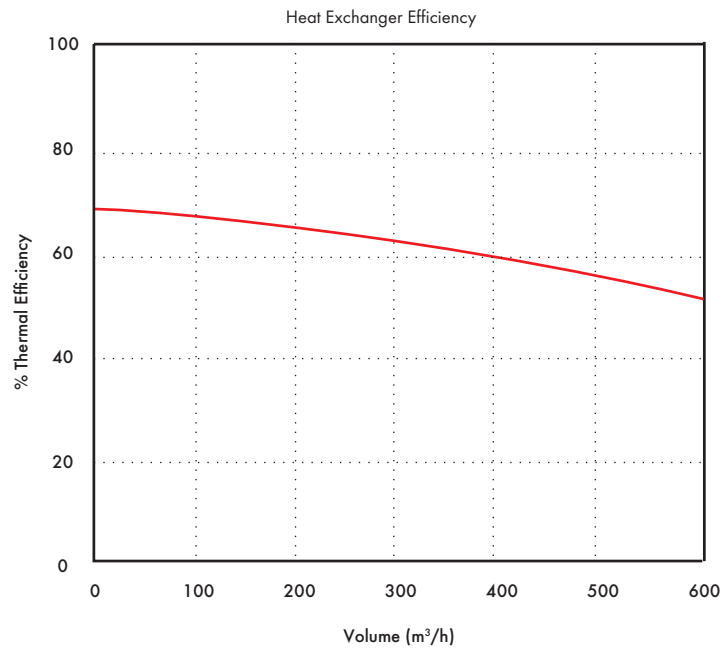

Airflow performance l/s (max)	Watts (max)	dB(A) @ 3m (max)	Weight kg
174 l/s	210	53	19

# HR500EP/IP

- Passive - no fans
- Lightweight - easy installation
- Up to 70% heat recovery
- Internal wall mounting HR500IP
- External wall mounting HR500EP

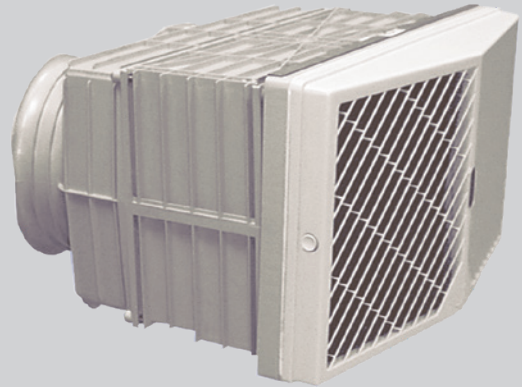

The unit is a semi-remote heat exchange unit with 70% heat recovery, designed for mounting in internal walls (HR500IP) and external walls (HR500EP) for installations using ducted extraction and fresh air supply. The HR500 units provides air movement via two independent in-line duct fans to suit length and configuration of ducting systems. The unit is ideal for use with in-line centrifugal type fans and compatible accessories. Performance of HR500EP and HR500IP: Up to 244 l/s FID capacity (balanced airflow). Ideal for computer rooms, classrooms, offices and the health & leisure industries.

## Model

Model	Stock Ref
HR500IP	370447
HR500EP	370451

## EP Unit

Hole opening: 610 x 381 mm

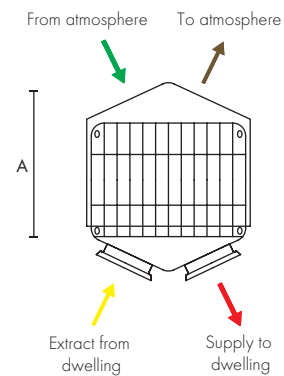

## IP Unit

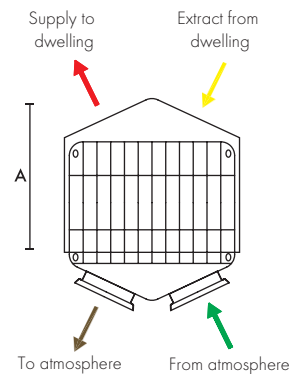



## Dimensions (mm)

EP & IP Unit

Hole opening: 610 x 381mm

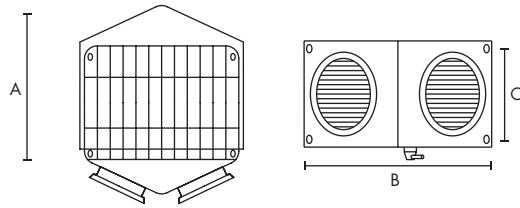

A	B	C
480-750	600	340

Weight: 9kg

## Performance

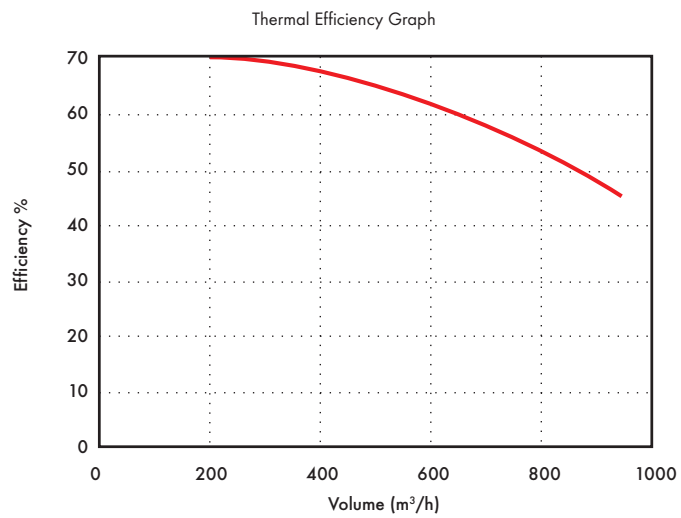
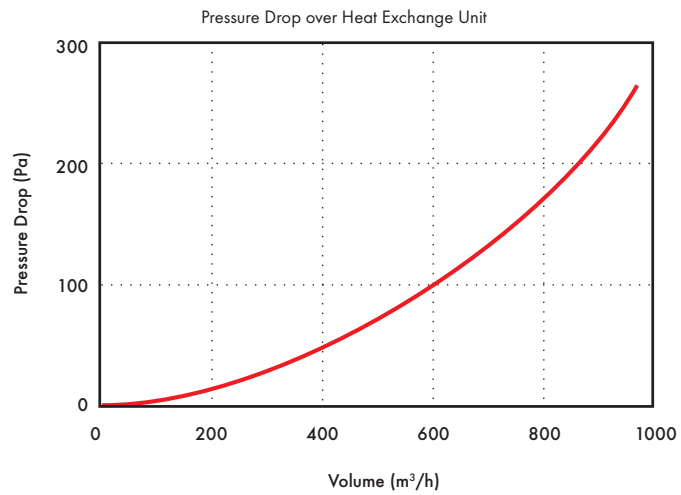

# HR500DP

- Passive - no fans
- Lightweight, compact and easy to install
- Up to 70% heat recovery
- Easy to clean

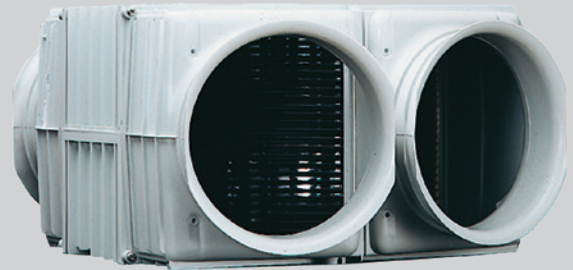

A 'stand alone' heat exchange module which will transfer up to 70% of the outgoing heat to incoming air. Polymeric construction with spigots to suit 200, 250 and 315mm Ø flexible ductwork.

Module accessible for routine cleaning. Condensate outlet provided. Ideal for use in air conditioned environments.

The heat exchanger works at the same high efficiency, automatically keeping a cool room cool.

Performance of the Heat Exchange Unit: At 180l/s achieves 70% temperature efficiency (balanced airflow). Ideal for schools, pubs, offices and leisure industries.

---

## Model

Model	Stock Ref
HR500DP	10538290

---

## Dimensions (mm)

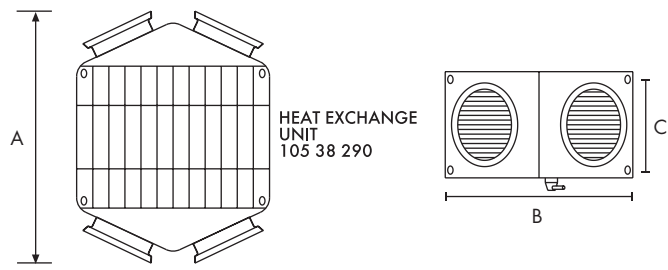

A

B

C

700

600

340

Weight: 9kg

## Performance

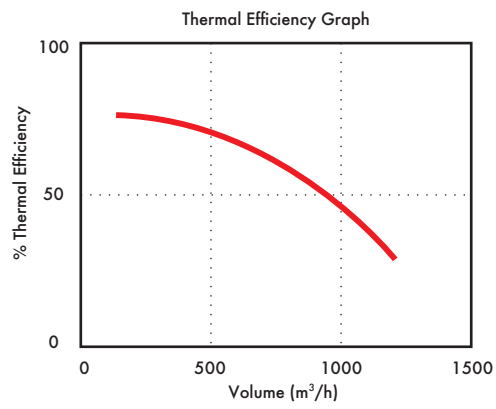
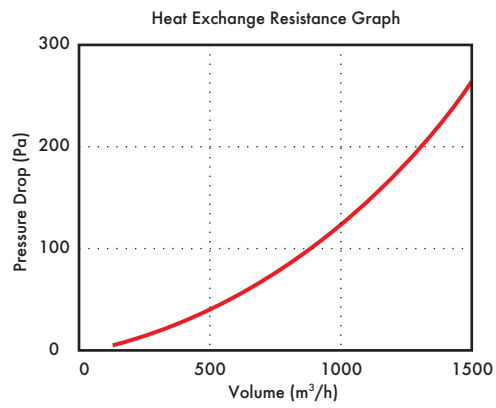

# Overheating Solutions



Vent-Axia has designed a range of ventilation solutions which help satisfy overheating requirements in dwellings and meet the latest Approved Document Part O requirements. Overheating in homes has been the subject of many a headline in recent years, with the UK experiencing hotter, drier summers and heatwaves.

Part O ventilation rates, should not mean nuisance noise levels. The Vent-Axia Lo-Carbon NBR Cool Unitary Fan provides heat extraction from habitable rooms whilst minimising noise. A brand new control platform provides fully adjustable airflow, meaning Part O rates can be achieved easily, with sound levels as low as 8.5dB(A) at 3 metres. The solution comes complete with a backdraught shutter to prevent nuisance draughts in habitable spaces.

Vent-Axia has also designed a complete all-in-one boxed solution to help satisfy overheating requirements in dwellings, offering 20l/s, 30l/s, and 50 l/s solutions along with passive supply replacement air options for higher flow rates. The NBR Coolbox Kit range achieves low sound levels by utilising energy efficient Mixed Flow In-Line fans that are now quieter, two and half times the pressure of conventional axial fans and more compact than traditional inline fans making them ideal for overheating extraction.

**Vent-Axia**<sup>®</sup>





Lo-Carbon NBR Cool Unitary Fan

E3 - E4

---



NBR CoolBox Kits

E5 - E8

---



Lo-Carbon Sentinel Econiq Cool-Flow

E9 - E16

---



Acoustic Residential Purge Ventilator

E17 - E18

---

# Lo-Carbon NBR Cool Unitary Fan

- Designed and manufactured in the UK
- Unitary solution to help combat overheating in dwellings
- On-demand overheating extraction
- Sound levels complying with Part F building regulations
- Easy to commission with variable speed
- Local room control or automatic temperature sensor
- Passive Supply replacement air kit available when extract totals > 60l/s



## Lo-Carbon NBR Cool Unitary Fan

Part O ventilation rates, should not mean nuisance noise levels. The Vent-Axia Lo-Carbon NBR Cool Unitary Fan, in 125mm, provides adequate ventilation whilst minimising noise.

The fan is designed in line with the Approved Document F and O 2021 Building Regulations.

The Lo-Carbon NBR Cool Unitary Fan has been designed to extract heat as and when the occupant needs heat extraction. As standard the Lo-Carbon NBR Cool Unitary Fan is set to run at 20 l/s which is adjustable.

The Lo-Carbon NBR Cool Unitary Fan also comes with the additional option of automatic temperature control, this would be triggered when the sensor reads 24 degrees or above.

A brand new control platform also provides fully adjustable airflow, meaning Part O rates can be achieved easily.

The solution comes complete with backdraught shutter to prevent nuisance draughts in habitable rooms.

## Near Silent Operation

The fan has been designed to be as discreet as possible for homeowners, with independently tested sound levels as low as 8.5dB(A).

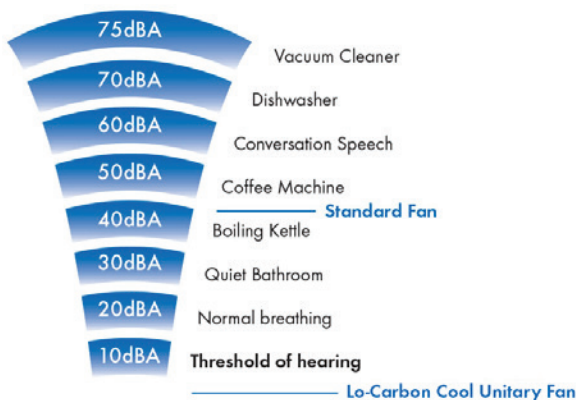

## Model

### Lo-Carbon NBR Cool Unitary Fan

For habitable rooms such as bedrooms and living rooms, our new 125mm heat extraction fan is the solution for developers with overheating issues. With a built-in temperature sensor as standard, automation or manual control are both an option.

Variable speed setting.

### Model

Lo-Carbon NBR Cool Unitary Fan

Stock Ref

412262

## Accessories

### Model

Wall Kit White 125mm

Wall Kit Brown 125mm

Wall Kit Terracotta 125mm

NBR Passive Duct Kit

Stock Ref

455226

497434

497432

412261

## Consultant Specification

The unitary overheating extract ventilation unit shall be the Lo-Carbon NBR Cool Unitary Fan as manufactured by Vent-Axia, exact unit sizing and specification shall be in accordance with the particular specification.

The Lo-Carbon NBR Cool Unitary Fan has been sized to meet the Part O extraction rates of up to 26 l/s, by default this is set to 20 l/s with manual control but this can be set to trigger at 24deg automatically through the built-in temperature sensor. Supplied with a 5 - year warranty.

The Lo-Carbon NBR Cool Unitary Fan should have variable speed settings of 5-26 l/s achieving a minimum noise level of 8.5dB(A) at 3 metres. All sound pressure levels are quoted at hemispherical measurements. All units shall be and independently third-party tested at the Sound Research Laboratory (SRL), tested to BS EN 13141-6.

The unit shall comprise a single high efficiency EC/DC motor to deliver specific fan powers as low as 0.09 W/l/s, as measured in accordance with the SAP PCDB test method and listed on the PCDB database.

The controls for the Lo-Carbon NBR Cool Unitary Fan unit shall provide fully adjustable, intermittent heat extraction rates. The Boost speed shall be activated via an integral temperature sensor or via LS Input.

The fan shall be compatible with low ceiling voids and have a spigot length of 66mm.

The unit should be commissioned as an Intermittent Heat Extraction fan based on the design duty required. By default this is 20 l/s.

## Dimensions (mm)

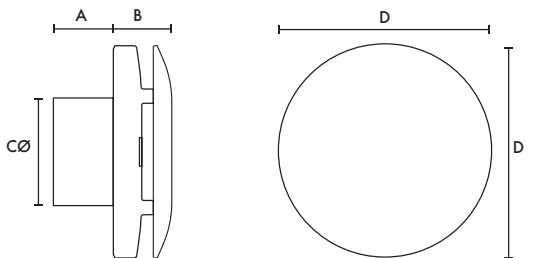

A	B	C	D
66	57	120	228



- 1 Rear cable entry
- 2 Side cable entry (cut plastic side wall to access)
- 3 100% variable speed adjustment
- 4 Installation mode (SW1)  
Back pressure detection system (SW2)

## Performance Guide

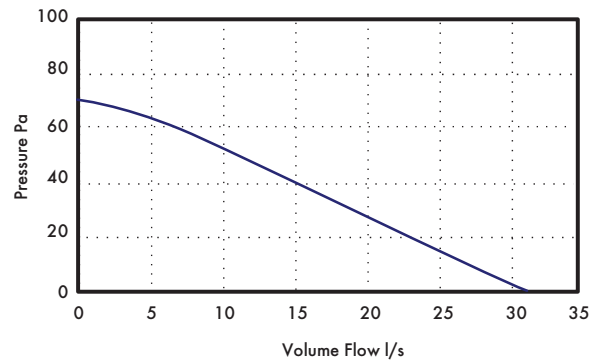

## Sound

Speed	dB(A)
Min	8.5
Max	37.9

## Installation Settings

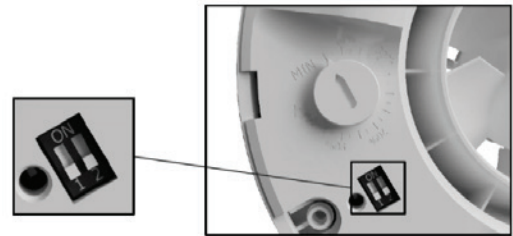

Dip Switch (SW1) (default OFF):

- OFF = Automatic Temperature Function Off (default)
- ON = Automatic Temperature Function On



# NBR CoolBox Kits

- Designed and manufactured in the UK
- Fully boxed solution to help combat overheating in dwellings
- On-demand overheating extraction.
- Sound levels complying with Part F Building Regulations
- 20l/s, 30l/s, and 50 l/s solutions
- Roof terminations not included but must not exceed 5pa of resistance at the relevant duties
- Passive supply replacement air option
- Local room control via remote switches or in room temperature sensors (by others)
- Easy to commission with predetermined speeds

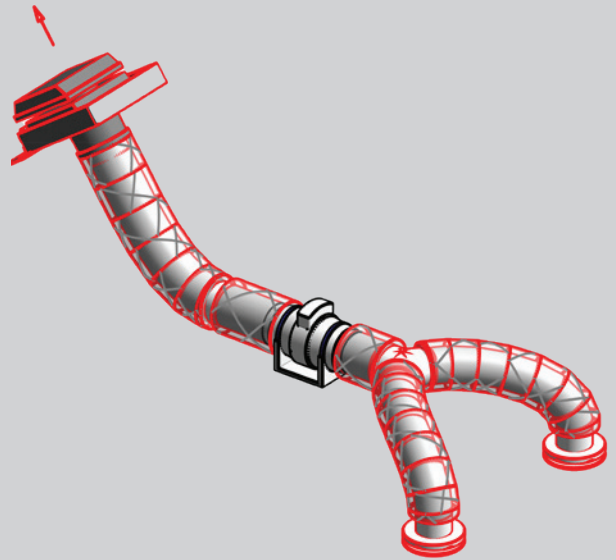

## Ducted Ventilation

Vent-Axia has designed a complete all in one boxed solution to help satisfy overheating requirements in dwellings, whilst achieving low sound levels with a range of kits that include energy efficient Mixed Flow In-Line fans that are now quieter, offer two and half times the pressure of conventional axial fans and are dimensionally more compact making them ideal for overheating extraction.

## Motors

The motor speed is selected on installation as per the Installation Guidance Sheet, motors are fitted with Standard Thermal Overload Protection (S.T.O.P.). All sizes with capacitor run motors. All sizes are Class II appliances. Supply voltage 220-240V/1/50Hz.

## Installation

These units have a separate footplate for simple mounting and detachable spigots for simple connection to ducting. The motor body chassis rotates to provide connection in acute spaces. Cleaning the product is simple as all parts can be removed without removing the ducting.

## Models

### Coolbox kits

Coolbox Inline Fan with Acoustic Mat, Insulated Ducting, Acoustic Flexible Duct, Worm Drive Clips, Backdraught Shutter, Y-Piece (30 and 50 Kits only), Extract Diffuser and Roof Termination by others.

Model	Stock Ref	Airflow
NBR CoolBox 20	412258	20l/s
NBR CoolBox 30	412259	30l/s
NBR CoolBox 50	412260	50l/s

### Passive kit

Insulated Flexible Duct 3m, Backdraught Shutter, Reducer, Supply Diffuser, Worm Drive Clips and Roof Termination by others.

Model	Stock Ref	Airflow
NBR Passive Duct Kit	412261	>60l/s

## Sound Data and Performance Guide

The sound data is based on the kits provided and an external roof vent supplied by others that conforms to at least 90% effective free area of the size of duct being used.

This equates to  $\geq 15,537\text{mm}^2$  for the NBR CoolBox 50/Passive Duct kit and for the NBR CoolBox 20/30  $\geq 11,039\text{mm}^2$ . The pressure of the roof vent must not exceed more than 5pa for the NBR CoolBox 50/Passive Duct kit and must not exceed more than 5pa for the NBR Coolbox 20/30 to provide the below sound levels and assurances of flow rate at the valve.

## Dimensions (mm)

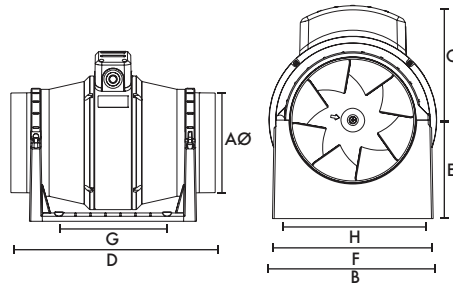

Model	NBR CoolBox 20/30	NBR CoolBox 50
AØ	122	147
B	178	200
C	124	138
D	259	350
E	96	118
F	168	192
G (fixing hole)	120	162
H (fixing hole)	153.5	178

## Sound Data and Performance Guide

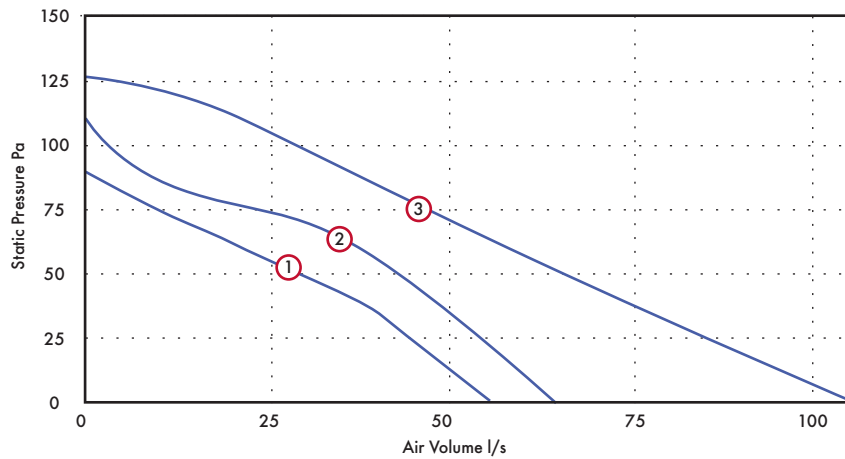

Model	Stock Ref	Flow Rate l/s	Dia mm	Speed	IP Rating	Curve Ref	Motor kW	F.L.C Amps	Estimated noise at 3m valve/s dB(A)
NBR CoolBox 20	412258	20	125	Low	IP44	1	0.03	0.12	25
NBR CoolBox 30	412259	30	125	Medium	IP44	2	0.03	0.12	22
NBR CoolBox 50	412260	50	150	Low	IP44	3	0.05	0.21	30
NBR Passive Duct Kit	412261	>60	150	n/a	n/a	n/a	n/a	n/a	n/a

## Installation Examples

### NBR CoolBox 20

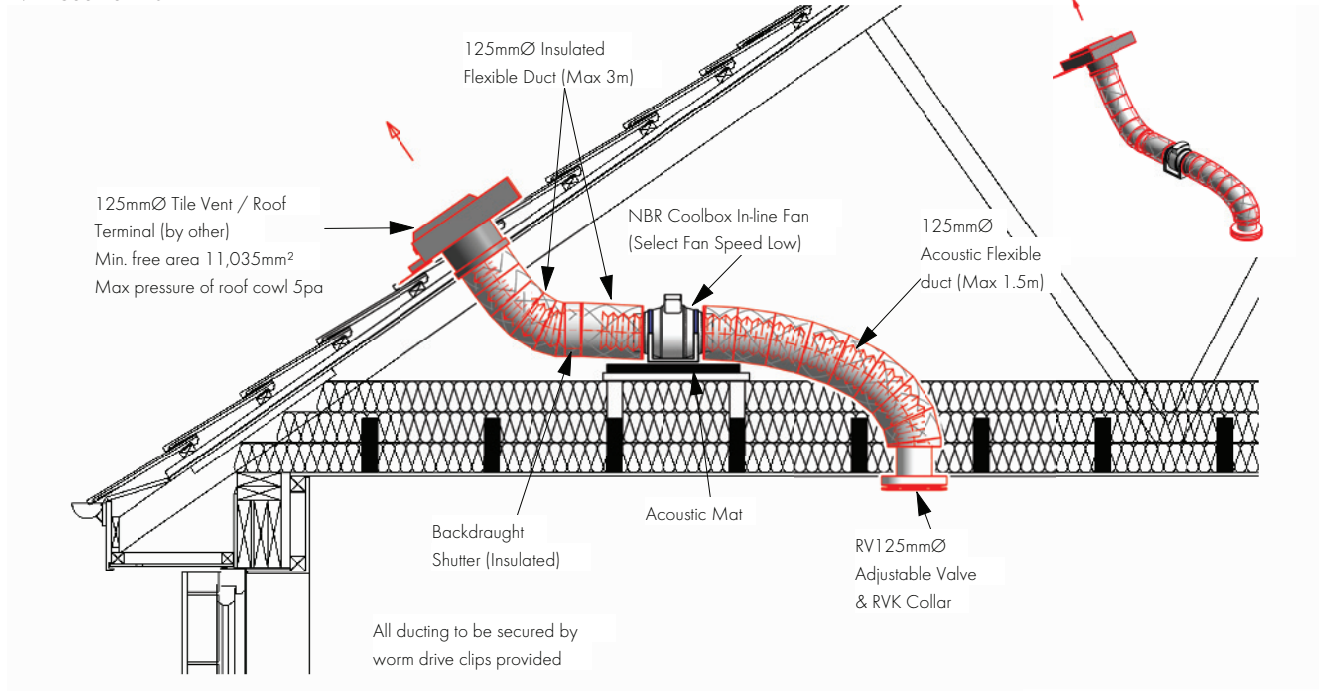

### NBR CoolBox 30

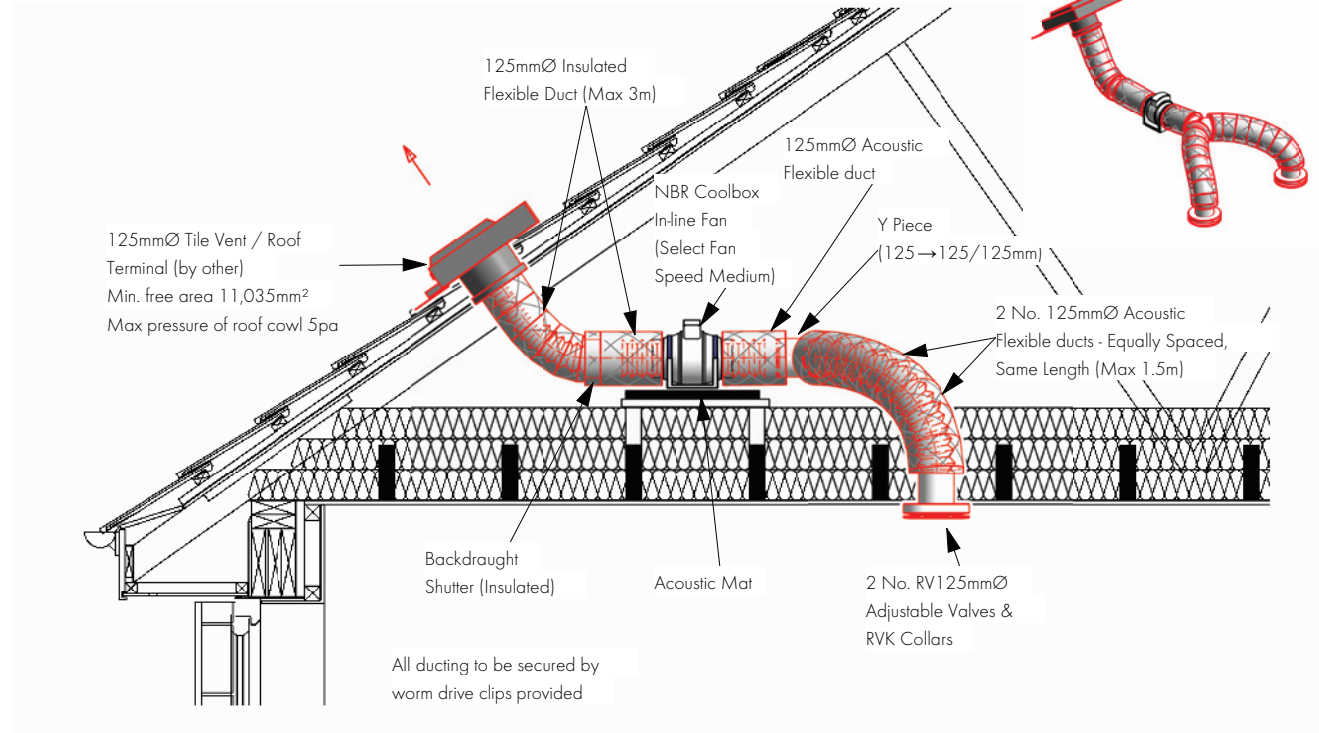

# Installation Examples

## NBR CoolBox 50

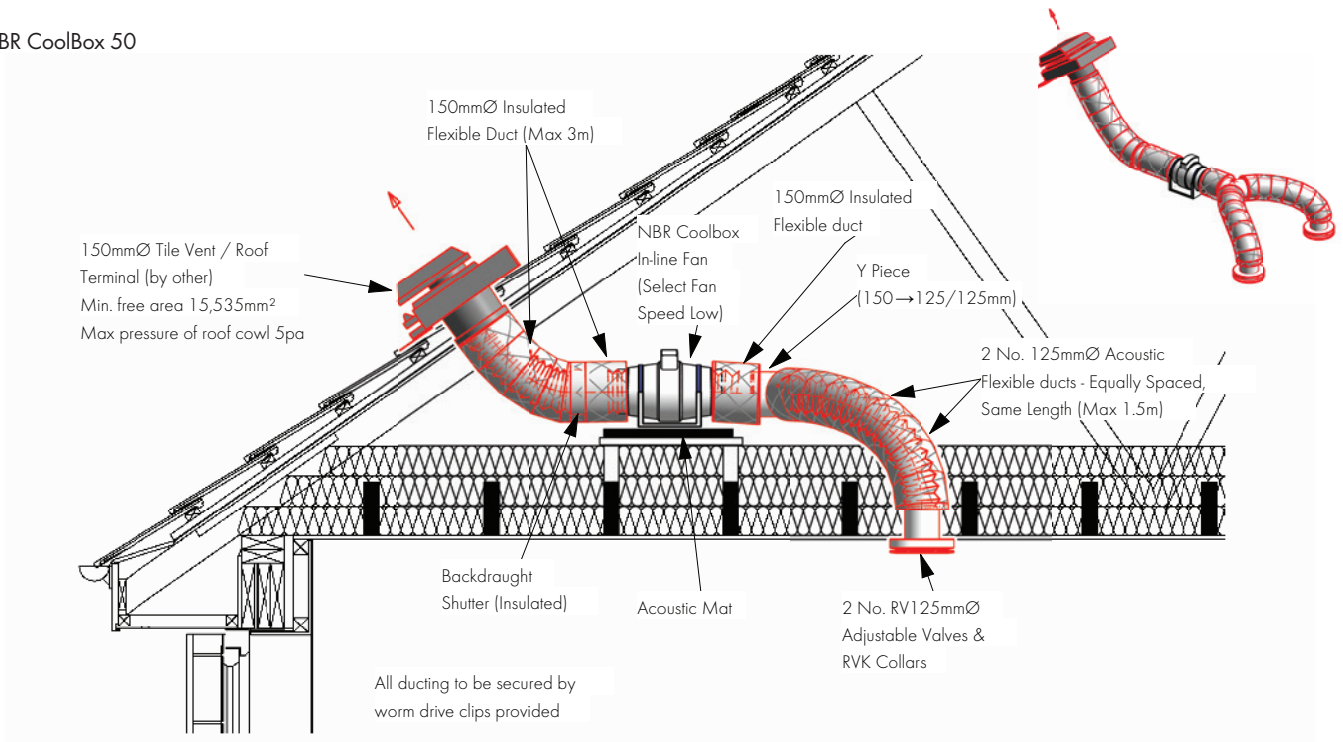

## NBR Passive Duct Kit

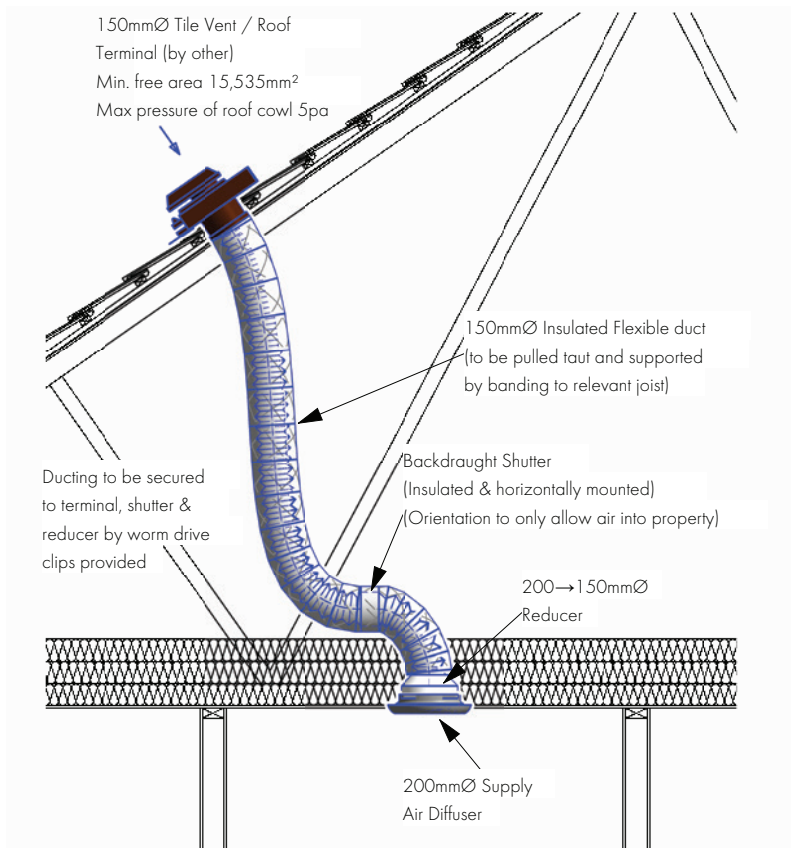

# Lo-Carbon Sentinel Econiq Cool-Flow

- Up to 4.37kW of total cooling provided
- Activated automatically at 25°C to prevent overheating to meet Part O and TM59
- Lowers fresh air supply temperature from ambient temperatures by up to 18°C
- R32 refrigerant with a GWP of 675, 50% lower than R134a
- EER up to 3.77
- App allowing full commissioning and control of activation
- Sentinel-X Wireless Temperature Sensors available
- Best in class SFP's and thermal efficiencies up to 93%
- Sound data independently tested and verified by SRL
- Wall mounted and Floor Standing options available
- Designed with 200mm spigots to provide maximum cooling and minimal noise levels all at low system pressures



Designed to mitigate overheating conditions in the warmer months meeting the requirements of Residential Part O and TM59 standards. Lo-Carbon Sentinel Econiq Cool-Flow is Vent-Axia's latest flagship mechanical ventilation with heat recovery system combined with our Intelligent Econiq Cool-Flow Module. Designed in the UK, it offers the highest level of comfort and functionality all year round.

Vent-Axia's Lo-Carbon Sentinel Econiq Cool-Flow is a self-contained solution designed to fit within a POD or standard utility cupboard. Connection to the unit will be made utilising the 200mm spigots and Vent-Axia's Thermflow ducting which will have a thermal conductivity of no less than 0.038 W/(m·K).

In the cooler months the Lo-Carbon Sentinel Econiq Cool-Flow provides up to 93% Heat Recovery ensuring heating bills are kept to an absolute minimum, in the warmer months our Intelligent 100% summer bypass will ensure free cooling is used wherever possible to ensure the internal comfort temperature is not exceeded.

If the 100% automatic intelligent summer bypass is not able to utilise internal/external free cooling conditions to reduce overheating, Vent-Axia's Lo-Carbon Sentinel Econiq Cool-Flow will automatically detect excessive increase in temperature within the dwelling. This will operate until the internal dwelling comfort temperature is met to ensure the dwelling does not overheat beyond Part O and TM59 parameters or the comfort temperatures set by the user.

Manual boost is also possible for the end user if they wish to override the automatic cooling mode as is the ability to turn then cooling on/off.

## Air Quality and Health

The MVHR filter options offer numerous benefits, including improved indoor air quality by removing allergens and particulate matter. They maintain the system's energy efficiency, reduce heating and cooling costs, and enhance the overall longevity of the system. Additionally, they capture bacteria, viruses and VOCs, promoting a healthier living environment. Regular filter maintenance extends the system's life span and ensures uninterrupted operation.

Whatever the outside environment, the system can help improve the indoor air quality by filtering out impurities, with ISO 60% Coarse (G4) supplied as standard, which can filter out sand, fine hair and particles larger than 10µm. Additional filtration can be achieved with a selection of optional filters, such as ISO ePM10 (M5), which can filter pollen, stone dust and particles smaller or equal to 10µm and ISO ePM2.5 (F7), which can filter out mould spores, bacteria and particles smaller or equal to 2.5µm.

The various sensor options allow for flexible installation in individual rooms, supporting effective management of the air in the home. For example, a wireless temperature sensor located within a habitable room helps ensure a healthy and safe environment. A humidity sensor located in the bathroom detects high levels of moisture can support good indoor air quality. CO<sub>2</sub> sensors can ensure the ppm levels are managed to help promote cognitive function.

## Low Noise Levels

The Lo-Carbon Sentinel Econiq Cool-Flow is one of the quietest combined MVHR and cooling systems on the market. The range is designed with an integral acoustic enclosure, made of steel, foam and expanded polypropylene (EPP), minimising breakout noise. The highly efficient motors are mounted on anti-vibration mounts to mitigate vibration transmission.

## MVHR Demand Control Ventilation

The Vent-Axia Connect smartphone application allows a multitude of functions to be adjusted from the comfort of the sofa, available on iOS and Android. With smartphone-compatible controls, the homeowner is in full control of their ventilation all year round. They have the flexibility to increase the ventilation rate during hot periods in the summer or reducing the speed to minimise running costs while away. The Sentinel control logic built within the MVHR ensures the system operates optimally with automated functions such as frost protection, summer bypass and cooling providing comfort in the home.



The Lo-Carbon Sentinel Econiq is Vent-Axia's latest flagship mechanical ventilation with heat recovery system. Designed and developed in the UK, it offers the highest level of comfort and functionality all year round.

Introducing a full range of products, with air performance suitable for all types of homes, the new Sentinel-X wireless controls platform delivers complete control over the home environment, provided through a full range of wired/wireless sensors and a smartphone app.



### Cooling Unit Control Strategy

The MVHR controller shall automatically switch between heat recovery, summer bypass and active cooling via the Econiq Cool-Flow Module, continuously measuring internal & external temperatures to maintain comfort thresholds efficiently. The Econiq Cool-Flow Module can only be activated if both MVHR fans are running. In addition to the standard automatic cooling, provision shall also be made to allow active cooling to be disabled and enabled:

- Cooling permanently switched off - the user may choose to isolate the Econiq Cool-Flow Module from the mains. As such the power supply should be monitored so as to not flag a fault under these (intentional) conditions
- Cooling disabled off by schedule - the user may choose either a weekly or databased schedule (e.g. Holiday mode) to prevent Econiq Cool-Flow Module to be active for the duration.
- Cooling enabled user override - Such as using a switch input on the MVHR overriding demand for cooling regardless of settings/schedules. The cooling unit will have additional temperature sensors built-in and flow rates may be increased automatically to ensure internal component temperatures are not exceeded, Econiq Cool-Flow Module may be temporarily disabled for a period to allow the compressor to cool down in extreme cases.

### A Whole New Experience

The highly sculpted interior surfaces, designed using the latest CFD techniques, ensure airflows are maximised through the unit, minimising noise and energy use. This feature alone provides an experience, that will delight homeowners, providing the most discrete and highly efficient ventilation available.

### Integral Humidity Sensor

The integral humidity sensor increases speed in proportion to relative humidity levels, saving energy and reducing noise. The sensor also reacts to small but rapid increases in humidity, even if the normal trigger threshold is not reached. This unique feature ensures adequate ventilation, even for the smallest wet room. The nighttime relative humidity setback feature suppresses nuisance tripping as humidity gradually increases with falling temperatures.

### Model

Description	Stock Ref
Sentinel Econiq Cool-Flow with Wall Mounted Kit	413887
Sentinel Econiq Cool-Flow with Floor Mounted Kit	413888

### Accessories

Description	Stock Ref
Wall Mounting Kit for Controller	411628

### Control/Sensor Overview

Power	Colour	CO <sub>2</sub>	PIR	Temp.	Humidity	Wireless	4 Speed Switch	Stock Ref
Battery	White			✓	✓	✓		496431
Battery	White			✓	✓	✓	✓	496437
Battery	Black			✓	✓	✓	✓	497689
0-10V	White	✓		✓	✓			496432
240V	White			✓	✓	✓		496429
240V	White	✓		✓	✓	✓		496433
240V	White		✓			✓		496438
240V	White			✓	✓	✓	✓	496620
240V	Black			✓	✓	✓	✓	497693
240V	White			✓	✓		✓	496621
240V	Black			✓	✓		✓	497697

### Spare Filters

Description	Stock Ref
ISO 60% Coarse (G4) Filter 2 per Pack	411690
ISO ePM10 50% (M5) Filter 1 per Pack	411691
ISO ePM2.5 70% (F7) Filter 1 per Pack	411692

### SEC Class

Model	SEC Class
Econiq L	A+

### SAP PCDB Test Results (Econiq L)

	Thermal Efficiency %	SFP (W/l/s)
K+1	93	0.56
K+2	93	0.53
K+3	93	0.56
K+4	92	0.62
K+5	91	0.72
K+6	91	0.84
K+7	90	1.01

### Spigot Configuration

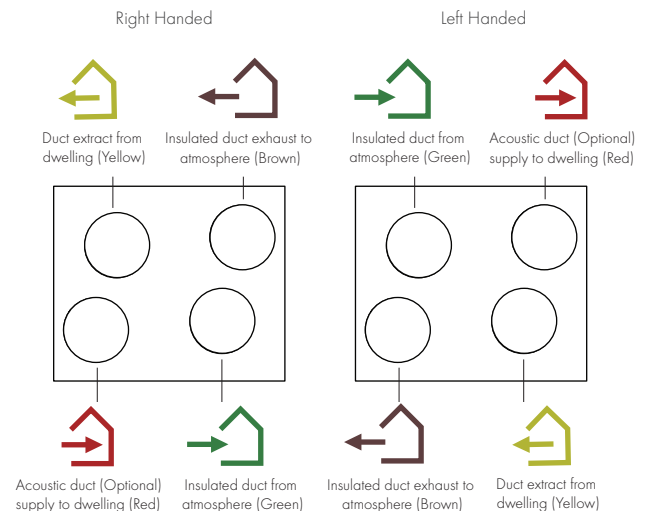



## Performance

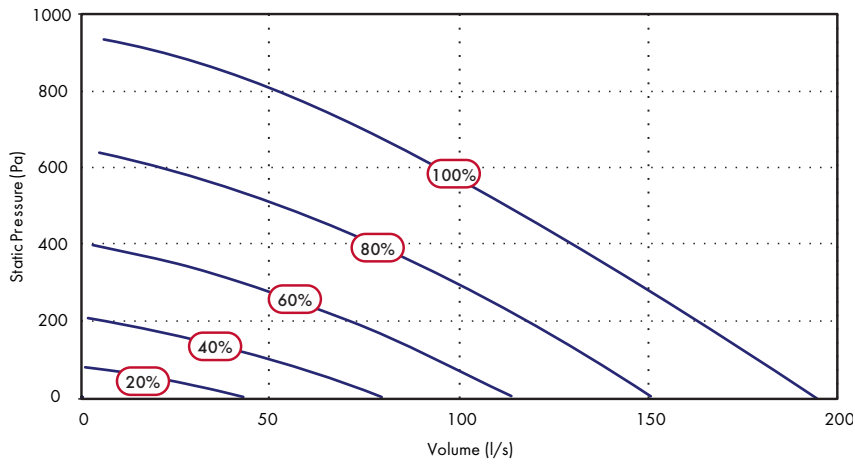

Please note: The Econiq Cool-Flow Module must have a minimum of 83 l/s from the MVHR to ensure components do not overheat. 20% and 40% fan curves are only to be used for the MVHR running without cooling.

External Conditions		Internal Conditions		Econiq Cool-Flow Module				Econiq Cool-Flow						
Dry Bulb Temp (°C)	Wet Bulb Temp (°C)	Dry Bulb Temp (°C)	Wet Bulb Temp (°C)	Airflow (l/s)	Supply Air Temp (°C)	Power In (kW)	Sensible Cooling Capacity (kW)	Total Cooling Capacity (kW)	EER	Power In (kW)	Sensible Cooling Capacity (kW)	Total Cooling Capacity (kW)	EER	
*	35	24	27	19	83	17.46	1.07	1.67	2.13	1.99	1.11	1.80	2.39	2.15
					111	17.57	1.02	2.19	2.71	2.65	1.11	2.39	3.21	2.89
					139	17.98	0.99	2.65	3.18	3.23	1.14	2.91	3.83	3.36
					167	18.00	0.96	3.14	3.75	3.92	1.16	3.49	4.37	3.77
	31	22	27	19	83	15.88	0.93	1.50	1.83	1.96	1.07	1.55	2.06	1.93
					111	16.11	0.98	1.98	2.40	2.45	1.08	2.04	2.62	2.42
					139	16.39	0.95	2.43	2.75	2.90	1.09	2.49	3.12	2.86
					167	16.47	0.93	2.47	3.10	3.34	1.12	2.97	3.72	3.32
**	27	19	27	19	83	13.54	0.98	1.43	1.67	1.70	1.01	1.38	1.69	1.68
					111	13.55	0.93	1.92	2.28	2.45	0.98	1.85	2.31	2.36
					139	14.18	0.91	2.31	2.48	2.72	1.03	2.20	2.52	2.45
					167	14.63	0.88	2.72	2.92	3.32	1.08	2.54	2.97	2.76

\* ErP & BS EN 13141-7:2021 Cooling performance test conditions

\*\* BS EN 13141-7:2021 Cooling performance test condition

## Sound Data (Sentinel Econiq Cool-Flow)

Conditions (Summer Bypass Closed)			Octave Band (Hz) Sound Power Levels (dB)										Sound Pressure dB(A)
Airflow (l/s)	Supply Speed (%)	Extract Speed (%)	Test Mode	63	125	250	500	1k	2k	4k	8k	Lw(A)	lp(A) @ 3m
83	53	51	Supply	66.6	62.5	61.3	56.1	53.7	47.3	37.5	28.1	58.8	41.3
			Extract	67.4	53	52.8	41.5	40.9	32.7	25.7	23.7	47.9	30.4
			Breakout	62	56.4	57.6	46.9	46.5	38.9	30.5	26.2	52.4	31.9
102	64	61	Supply	66.5	64.5	67.3	62	57.1	51.8	41.5	30.7	63.7	46.2
			Extract	70.9	56	54.2	43.8	42.5	35.5	28.5	24.5	50	32.5
			Breakout	61.3	59.7	56.7	51.3	49.3	43	35.3	29.3	54.3	33.8
111	74	71	Supply	67.7	66.4	62.4	66.6	59	54.3	44.9	33.8	65.4	47.9
			Extract	71.1	56.8	53.6	46.6	43.1	37.1	29	26.4	50.5	33
			Breakout	61.7	62.3	56.3	58	51	45.6	36.5	29.4	57.2	36.7
132	77	77	Supply	68.2	67.5	63	68.3	59.9	55.8	47.1	35.7	66.9	49.4
			Extract	71.4	57.5	55	48.5	44.8	38.9	30.5	25.8	51.8	34.3
			Breakout	62.3	61.8	56.6	59.6	52.2	47	37.7	29	58.2	37.7
139	88	84	Supply	70.1	68.9	65	69.7	62.1	58.2	51.1	40	68.7	51.2
			Extract	70.9	59.5	55.4	51	46.6	40.8	33.7	26.3	53.2	35.7
			Breakout	64.1	63.7	57.5	57.9	53.6	49	41.1	31.9	58.7	38.2
167	100	100	Supply	79.7	72.7	67.2	71.5	64.6	60.8	55.5	44.8	71.2	53.7
			Extract	76	63.1	57.8	52.5	49.2	43.8	38.2	27.2	56.1	38.6
			Breakout	68.7	66.4	58.8	62.4	57.2	52.3	45.9	34.7	62.8	42.3

## Sound Data (Sentinel Econiq L MVHR only)

Conditions		Octave Band (Hz) Sound Power Levels, dB										SPL dB(A)
Speed	Test mode	63	125	250	500	1k	2k	4k	8k	LwA	SPL dB(A) @ 3m	
20%	Supply	52.9	50.9	46.8	43.0	34.6	27.1	19.2	25.4	43.9	26.4	
	Extract	50.3	49.0	36.0	31.5	23.6	16.1	18.9	25.3	36.4	18.9	
	Breakout	34.6	34.8	35.7	34.9	29.6	25.1	21.0	25.3	36.0	15.5	
40%	Supply	59.5	56.5	59.4	55.0	48.2	42.6	31.8	26.1	55.9	38.4	
	Extract	51.9	51.3	50.4	41.2	35.0	25.3	19.8	25.4	44.8	27.3	
	Breakout	40.2	42.6	46.5	45.4	41.0	36.2	25.5	25.3	46.5	26.0	
60%	Supply	66.9	62.4	63.3	62.0	57.9	53.5	43.4	34.2	63.2	45.7	
	Extract	60.6	60.3	54.2	49.5	44.4	36.2	27.9	26.3	51.7	34.2	
	Breakout	45.5	49.8	52.5	53.1	49.7	46.7	36.2	26.9	54.5	34.0	
80%	Supply	82.4	67.6	65.2	67.6	64.2	60.8	50.8	43.2	69.2	51.7	
	Extract	75.5	68.6	59.3	56.0	48.3	44.2	36.9	31.3	58.6	41.1	
	Breakout	59.2	55.0	56.8	60.0	55.4	53.9	44.1	33.4	61.0	40.5	
100%	Supply	79.4	69.6	66.6	75.1	64.9	63.6	53.4	45.7	73.7	56.2	
	Extract	72.4	70.5	60.5	56.4	49.8	46.3	39.0	33.4	59.5	42.0	
	Breakout	63.0	57.1	58.5	63.7	56.8	55.9	46.4	36.2	63.5	43.0	



### Unit Dimensions (mm)

Econiq Cool-Flow Module Weight: 50kg. Total Solution Weight: 96kg (including MVHR unit).

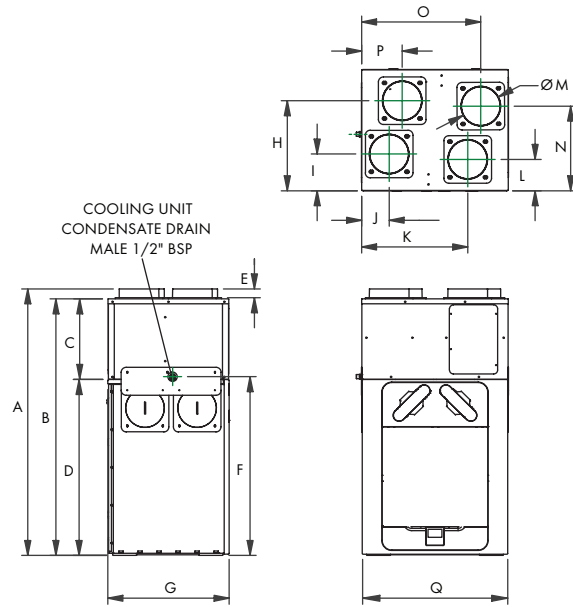

A	B	C	D	E	F	G	H	I	J	K	L	M	N	O	P	Q
1335	1285	403	881	45	895	608	451	184	138	531	157	200	424	597	204	736

Wiring connections front and back, allowing LH & RH fitting by rotating unit 180deg

### Mounting Dimensions (mm)

Wall

Floor

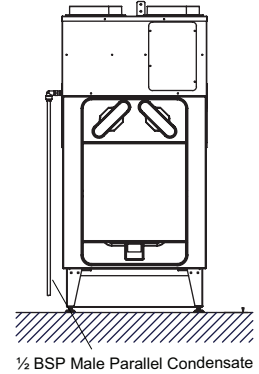
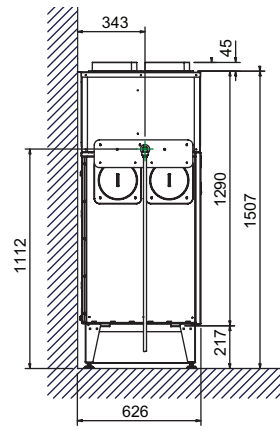
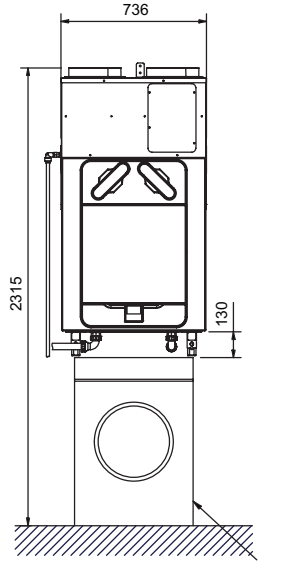
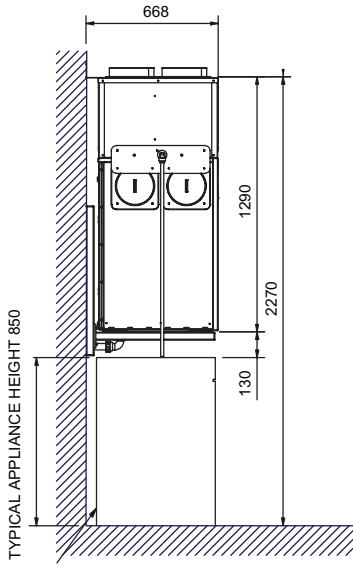

## MVHR Overview

	Sentinel Econiq L
Recommended max system flow	167 l/s @ 150 Pa
Part F Compliant App Commissioning Certificate	✓
RF858 connectivity, 802.11b/g/n WiFi and Bluetooth low energy 4.2	✓
Spigot Options	Vertical Only
Spigot size	200mm
Left/Right Hand Orientation Through Control	✓
Fully automatic 100% summer bypass	✓
Active Frost Protection to -20°C	✓
Fault Code Indicator	✓
Easy Access Filters: ISO Coarse 65% (G4)	✓
Easy Access Filters: ISO ePM10 50% (M5)	○
Easy Access Filters: ISO ePM2.5 70% (F7)	○
Clean Filter Indicator (Time frame)	✓
PIN Number Lock	✓
Running Time Indicator	✓
Enthalpy Heat Exchanger	○
Soft-Start Boost	✓
Delay-On	✓
Number of controllable speeds	4
Installer function to copy/load unit setup	✓
Inputs 2 x 0-10V; 2 x LS; 5 x Volt-Free	✓
Integral Humidistat	✓
Relay outputs - For example control heaters or geothermal heat exchanger	○
BMS - modbus supported over RS485	✓
Operating ambient temperature (°C)	-20 to +40
Operating Humidity (%RH)	0 to 95
Mounting	Wall or Floor
Maintenance access	From Front

○ - Denote Optional

## Econiq Cool-Flow Module Overview

Up to 4.37kW of total cooling provided	✓
Activated automatically at 25°C to prevent overheating to meet Part O and TM59	✓
Utilising R32 refrigerant providing a GWP of 675	✓
EER up to 3.77	✓
Lowers incoming air by up to 18°C	✓

## Consultant's Specification

### Specification - Econiq Cool-Flow Module

The Econiq Cool-Flow Module shall be manufactured with a RAL 9003 powder coated mild steel outer case construction and be fully insulated for thermal and acoustic performance.

The unit shall have easy access to the front of the unit via the access panel for access to Controls (including Control PCBA, Run Capacitor, Relay and connections board).

The Econiq Cool-Flow Module shall include a factory fitted gasket creating an airtight seal with the MVHR. The Econiq Cool-Flow Module shall also be supplied with mounting brackets to mechanically fix the Econiq Cool-Flow Module to the MVHR along with an upper bracket to be fitted between the Econiq Cool-Flow Module and the wall, ensuring unit stability.

The maximum weight of the combined solution shall not exceed 100kg for the Econiq Cool-Flow Module and MVHR combined, the Lo-Carbon Sentinel Econiq Cool-Flow.

The MVHR and Cooling module assembly shall be supported on the specific floor-mounting stand or specific prefabricated steel brackets.

The Vent-Axia Econiq Cool-Flow Module shall operate in unison with the MVHR unit and never independently.

The Econiq Cool-Flow Module shall provide up to 4.37kW of total cooling, and utilise R32 refrigerant providing a GWP of 675 whilst providing an EER of up to 3.77.

The Lo-Carbon Sentinel Econiq Cool-Flow shall be capable of lowering fresh air supply temperature by up to 18°C.

The Econiq Cool-Flow Module shall be supplied with a two year (parts only) warranty.

Connection to the unit will be made at the 200mm spigots utilising Vent-Axia Thermflow ducting which will have a thermal conductivity of no less than 0.038 W/(m·K).

Condensate Connection will be via the single side which is a LH condensate as standard utilising ½ BSP Parallel, Male threaded connection.

All ducting throughout the system to be fully insulated

### Specification - MVHR Unit

The Mechanical Ventilation Heat Recovery Unit shall be the Lo-Carbon Sentinel Econiq L as manufactured by Vent-Axia. It should be sized as indicated on the drawings and shall be in accordance with the particular specification.

The unit shall be fully insulated for thermal and acoustic performance and shall incorporate a high-efficiency composite plastic counter-flow heat exchanger with an independently verified thermal efficiency of up to 93% when tested to EN 308.

The heat exchanger shall be protected by ISO 60% Coarse (G4) grade filters on both exhaust and supply with the facility to accommodate ISO ePM10 (M5), ePM2.5 (F7) or an inline filter such as the Vent-Axia Pure Air Carbon Filter. The built-in filters shall be accessible via tool-free access doors. The heat exchanger, motors, summer bypass and all other serviceable parts shall be accessible through the front of the unit.

The Lo-Carbon Sentinel Econiq L shall automatically vary the ventilation rate via EC/DC motors, as it receives signals from optional or in-built sensor inputs. When a signal is received, the fans shall either vary their speed proportionally or on a normal/boost principle. The unit shall have the facility to commission the supply and extract fans individually via in-built minimum and maximum speed adjustment, alternative wired remote-control unit or via a compatible smartphone using the Vent-Axia Connect application. The fans themselves shall have independent, infinitely variable speed control.

The MVHR unit shall be manufactured with an ABS Outer case construction and an Expanded Polystyrene (EPS) inner chassis with custom motor and impeller mounting features. The inner chassis will assist in reducing noise and act as a large anti-vibration mount avoiding transmission through to the back mounting plate or the base of the unit. The MVHR unit shall be tested to ensure it meets the maximum allowable vibration of no more than 1 mm/s, measured on the unit wall fixing points.

The unit shall have a fully automatic 100% summer bypass, integral minimum and maximum infinitely variable speed controls with fascia mounted failure indication. The unit shall have low-energy, high efficiency EC/DC fan/motor assemblies with sealed for life bearings. The impellers shall be high-efficiency backward curved centrifugal type, achieving an SFP as low as 0.38W/l/s [EN 308].

The unit shall have two condensate drain outlets for handing to be defined onsite and during commissioning. The unit shall have wireless control capability options, using RF868 connectivity, 802.11b/g/n Wi-Fi and Bluetooth low energy 4.2. The unit shall use RF868 to connect to a wide ecosystem of wireless sensors including but not limited to CO<sub>2</sub>, temperature, and relative humidity. The unit shall be able to engage Wi-Fi to

connect to local devices and create a local area network to allow for a larger network to be created for commissioning. The unit shall have Bluetooth low energy 4.2 to allow connectivity onto compatible smartphone devices. The unit shall be constructed with a removable tool free front panel which gives access to the removable on-board controller and other accessories. The EPS panel can then be removed with 4 screws allowing full maintenance access. This shall provide access to the following:

- ✓ Supply or extract fan
- ✓ Heat exchanger
- ✓ Access to the electrical connections

Access shall be provided for wiring termination and setup/commissioning. The unit can be supplied with either a backlit user interface or a blank plate, both of which shall be removable for remote mounting if required. Filters shall be accessed via the two filter drawers found near the top of the unit, the S shall have filter drawers and the M and L shall have filter caps.

Units shall be manufactured by Vent-Axia Ltd.

### Standard MVHR Controls

The Lo-Carbon Sentinel Econiq L shall incorporate the following functions through a user interface fitted by the manufacturer or a paired smartphone with the Vent-Axia Connect application:

- ✓ Integral infinitely variable fan speed control on supply and extract.
- ✓ 6 speeds; 4 adjustable
- ✓ Left or Right hand spigot configuration, programmable during commissioning
- ✓ Tool free filter access
- ✓ Integral BMS interfaces - control and status indication
- ✓ Heating interlocks
- ✓ 24V external sensor supply, e.g. PIR sensor
- ✓ 0-10V proportional speed adjustment
- ✓ Volt free contacts
- ✓ Fully automatic summer bypass
- ✓ Filter check facility
- ✓ Control panel PIN number lock

The unit shall incorporate:

- ✓ An integral humidity sensor with the following features: Ambient Response; Raises the humidity trigger point as dwelling temperature reduces.
- ✓ Rapid Response: Monitors the rate of change in humidity and triggers increased airflow even if the humidity trigger threshold is not reached.
- ✓ Proportional Response; incrementally increases the fan speed to reduce noise and reduce energy consumption.
- ✓ RS485 connectivity - Long distance cabling to support multiple sensor connections.
- ✓ RF868 connectivity - Radio reference 868 MHz for multiple wireless sensors pairing Bluetooth low energy 4.2 - Enable pairing within compatible smartphone device
- ✓ 802.11b/g/n Wi-Fi - Enable localised access point or connect to the local area network using the Vent-Axia Connect application, via a compatible smartphone device
- ✓ The unit shall incorporate an automatic 100% summer bypass damper which monitors internal and external temperatures to maintain the user comfort temperature (default 25°C): -
- ✓ 'Evening Fresh' turns the unit to maximum speed with the bypass operational for 2 hours or until the user comfort temperature is reached (default 25°C).
- ✓ 'Night Time Fresh' will run the unit at maximum speed with the bypass operational throughout the night or until the dwelling reaches minimum temperature (default 14°C).

Independently acoustically tested to BS EN 13141-7:2010

### Econiq Cool-Flow Module Controls

The MVHR controller shall automatically switch between heat recovery, summer bypass and active cooling via the Econiq Cool-Flow Module, continuously measuring internal & external temperatures to maintain comfort thresholds efficiently. The Econiq Cool-Flow Module can only be activated if both MVHR fans are running.

In addition to the standard automatic cooling, provision shall also be made to allow active cooling to be disabled and enabled:

- ✓ Cooling permanently switched off - the user may choose to isolate the Econiq Cool-Flow Module from the mains. As such the power supply should be monitored so as to not flag a fault under these (intentional) conditions
- ✓ Cooling disabled off by schedule - the user may choose either a weekly or date-based schedule (e.g. holiday mode) to prevent Econiq Cool-Flow Module to be active for the duration.
- ✓ Cooling enabled user override - Such as using a switch input on the MVHR overriding demand for cooling regardless of settings/schedules.

The Econiq Cool-Flow Module will have additional temperature sensors built-in and flow rates may be increased automatically to ensure internal component temperatures are not exceeded, Econiq Cool-Flow Module may be temporarily disabled for a period to allow the compressor to cool down in extreme cases.

# Sentinel-X Controllers

## Battery Controllers & Sensors



### Battery - Internal Temperature and Humidity - Wireless

Room mounted humidity and temperature sensor for wired or wireless communication with a compatible system. Using an in-built RF 868 MHz (Wireless radio frequency), or RS485 (Wired connection) communication method whilst being powered by batteries.

- Dimensions (HxWxD) (mm) 60 x 60 x 22
- 2 x AAA Batteries included
- Temperature range 0~60°C
- Relative humidity range 0-90% RH
- Wireless range 20m closed/100m open
- RF 868MHz Wireless or RS485 Wired communication
- Status LED indicator for pairing, health check and fault conditions
- Mounted using provided back plate

Stock Ref

496431



### Battery - 4 Speed Switch with Temperature and Humidity - Wireless

Room mounted Speed Switch for wireless communication with a compatible system. Using an in-built RF 868 MHz (Wireless radio frequency) communication whilst being powered by batteries.

- Dimensions (HxWxD) (mm) 90 x 90 x 17
- 2 x AAA Batteries included
- Temperature range 0~60°C
- Relative humidity range 0-90% RH
- Wireless range 20m closed/100m open
- RF 868MHz Wireless
- Mounted using provided back plate or compatible with a standard single gang or surface mounted pattress box
- Status LED indicator for pairing, health check and fault conditions

Model

Stock Ref

White

496437

Black

497689

## HMI Kit



### Wall-mounted HMI Kit to suit Econiq models with full HMI

Includes HMI Blank controller, HMI backplate and cable.

- Dimensions (HxWxD) (mm) 90 x 90 x 17
- Power supply 240V
- Wireless range 20m closed/100m open
- RF 868MHz Wireless or RS485 Wired communication
- Compatible with standard single gang or surface mounted pattress box

Stock Ref

411628

## 24V Sensor



### 0-10V CO<sub>2</sub>, Temperature and Humidity - Wired

Room mounted CO<sub>2</sub> sensor with 0-10V signal output powered by an external 24V supply.

- Dimensions (HxWxD) (mm) 90 x 90 x 17
- 24V Power supply required
- Temperature range 0~60°C
- Relative humidity range 0-90% RH
- CO<sub>2</sub> range 0-2000PPM
- Compatible with standard single gang or surface mounted pattress box
- Status LED indicator for pairing, health check, faults & air quality traffic light index
- 0-10V Wired Communication

Stock Ref

496432

# Sentinel-X Controllers

## 240V Controllers & Sensors



### 240V - Internal Temperature and Humidity - Wireless

Room mounted humidity and temperature sensor for wired or wireless communication with a compatible system. Using an in-built RF 868 MHz (Wireless radio frequency), or RS485 (Wired connection) communication method whilst being powered by a local 240V supply.

- Dimensions (HxWxD) (mm) 90 x 90 x 17
- Power supply 240V
- Temperature range 0~60°C
- Relative humidity range 0-90% RH
- Wireless range 20m closed/100m open
- RF 868MHz Wireless or RS485 Wired communication
- Compatible with standard single gang or surface mounted pattress box
- Status LED indicator for pairing, health check, faults & air quality traffic light index

Stock Ref  
**496429**



### 240V - CO<sub>2</sub>, Temperature and Humidity - Wireless

Room mounted CO<sub>2</sub> sensor for wired or wireless communication with a compatible system. Using an in-built RF 868 MHz (Wireless radio frequency), or RS485 (Wired connection) communication method whilst being powered by a local 240V supply.

- Dimensions (HxWxD) (mm) 90 x 90 x 17
- Power supply 240V
- Temperature range 0~60°C
- Relative humidity range 0-90% RH
- CO<sub>2</sub> Range 0-2000 PPM
- Wireless range 20m closed/100m open
- RF 868MHz Wireless or RS485 Wired communication
- Compatible with standard single gang or surface mounted pattress box
- Status LED indicator for pairing, health check, faults & air quality traffic light index

Stock Ref  
**496433**



### 240V - 4 Speed Switch with Temperature and Humidity - Wired

Room mounted Speed Switch for wired communication with a compatible system. Using an in-built RS485 communication method powered by a local 240V supply.

- Dimensions (HxWxD) (mm) 90 x 90 x 17
- Power Supply 240V
- Temperature range 0~60°C
- Relative humidity range 0-90% RH
- Mounted using provided back plate or compatible with standard single gang or surface mounted pattress box
- Status LED indicator for pairing, health check and fault conditions
- RS485 Wired Connection

Model  
White  
Black

Stock Ref  
**496621**  
**497697**



### 240V - 4 Speed Switch with Temperature and Humidity - Wireless

Room mounted Speed Switch for wireless communication with a compatible system. Using an in-built RF 868 MHz (Wireless radio frequency) communication method whilst being powered by a local 240V supply.

- Dimensions (HxWxD) (mm) 90 x 90 x 17
- Power Supply 240V
- Temperature range 0~60°C
- Relative humidity range 0-90% RH
- Wireless range 20m closed/100m open
- RF 868MHz Wireless
- Mounted using provided back plate or compatible with standard single gang or surface mounted pattress box
- Status LED indicator for pairing, health check and fault conditions

Model  
White  
Black

Stock Ref  
**496620**  
**497693**



### 240V - PIR Sensor - Wireless

Room mounted PIR sensor for wired or wireless communication with a compatible system. Using an in-built RF 868 MHz (Wireless radio frequency), or RS485 (Wired connection) communication method whilst being powered by a local 240V supply. Room mounted presence detector for min/max or on/off control. Wall or ceiling mounting.

- Dimensions (HxWxD) (mm) 90 x 90 x 17
- Power supply 240V
- 5-25min run on timer
- PIR Range 3m
- Compatible with standard single gang or surface mounted pattress box
- Wireless range 20m closed/100m open
- RF 868MHz Wireless or RS485 Wired communication

Stock Ref  
**496438**

# Acoustic Residential Purge Ventilator

- Rapid local extract
- Satisfies Part F purge requirements
- Acoustically treated for low noise
- Helps to reduce overheating
- Can be used in conjunction with MVHR and MEV units or as standalone system
- 220x90 or 250 diameter spigots
- Low profile design
- Easy setup
- Energy efficient EC fan
- Variable speed control
- Low maintenance requirement



The Vent-Axia Acoustic Purge Fan is used to rapidly remove indoor pollutants as well as reducing the impact of overheating in residential dwellings, providing a more comfortable and healthy internal environment for home-owners.

The Acoustic Purge Fan can be used in conjunction with a Sentinel Kinetic MVHR unit or independently via a separate switched live connection or 0-10V external sensor input. The Acoustic Purge Fan can be installed in habitable rooms to satisfy Approved Document F Purge requirements (4 air changes per hour). The unit can be installed in conjunction with controllable duct dampers and/ or background ventilators to manage the supply air into the dwelling under purge operation.

The Acoustic Purge Fan is specially treated with acoustic foam to reduce breakout and induct noise, ensuring end-user comfort during operation. As well as boasting a low-profile design, the unit utilises 220x90 spigots to allow easy use of flat ducting in tight void spaces in apartments.

## Model

Model	Stock Ref
Acoustic Purge Fan	477988
Acoustic Purge Fan XL	479829

## Accessories

Model	Stock Ref
Remote Speed Control	10520602
Trickle/Boost Controller	475775

## Dimensions (mm)

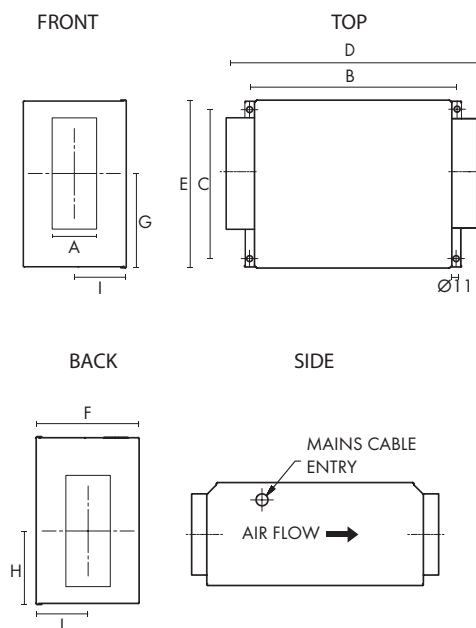

Stock Ref	Spigot	A	B	C	D	E	F	G	H	I	kg
477988	220x90	85	380	275	456	310	191	165	145	103.5	7.5
479829	250Ø	250	435	330	511	364	287	182	122	143	13

# Performance

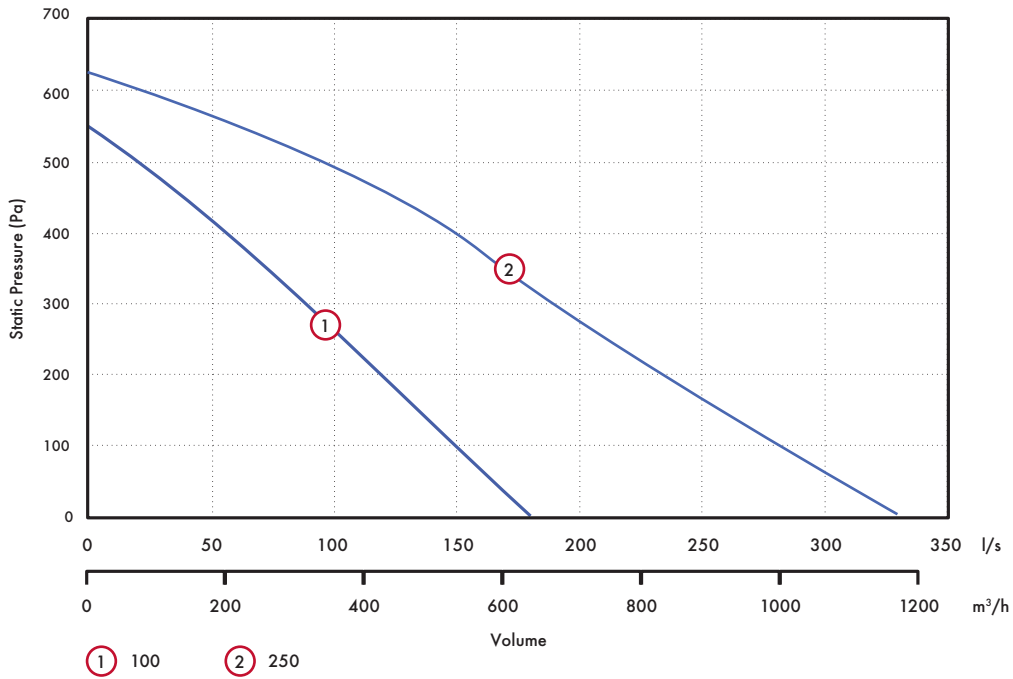

# Sound Data

## Acoustic Purge Fan

Speed	Test mode	Octave Band (Hz) Sound Power Levels, dB								dB(A) @	
		63	125	250	500	1k	2k	4k	8k	LwA	3m
25%	Inlet	35	30	34	32	26	20	18	24	32	15
	Outlet	36	32	36	34	33	28	20	23	37	19
	Breakout	37	34	31	28	24	18	18	23	30	10
50%	Inlet	40	38	51	47	41	38	31	26	48	31
	Outlet	40	44	57	51	50	49	43	31	56	38
	Breakout	43	46	50	46	43	39	32	27	48	27
80%	Inlet	45	45	60	60	52	49	44	40	59	42
	Outlet	50	50	68	65	61	61	56	49	68	50
	Breakout	64	53	57	58	54	50	47	45	59	39
100%	Inlet	55	46	60	61	53	50	45	41	60	43
	Outlet	53	51	65	66	62	63	57	51	68	51
	Breakout	56	54	57	60	56	52	49	47	61	41

## Acoustic Purge Fan XL

Speed	Test mode	Octave Band (Hz) Sound Power Levels, dB								dB(A) @	
		63	125	250	500	1k	2k	4k	8k	LwA	3m
25%	Inlet	48	49	42	38	35	24	24	29	40	22
	Outlet	47	46	41	37	41	29	24	29	42	24
	Breakout	42	42	37	31	29	26	25	31	40	19
50%	Inlet	55	57	65	58	49	43	45	38	57	39
	Outlet	53	57	62	58	54	55	51	36	59	41
	Breakout	52	48	53	43	37	36	34	30	48	27
80%	Inlet	63	65	69	76	62	54	53	49	71	53
	Outlet	63	66	69	72	69	68	62	55	72	54
	Breakout	54	56	57	57	48	46	45	36	57	36
100%	Inlet	68	71	72	80	68	62	59	56	76	58
	Outlet	68	71	70	78	75	75	68	63	78	60
	Breakout	61	63	62	62	55	54	52	45	63	42

# Wiring Diagram

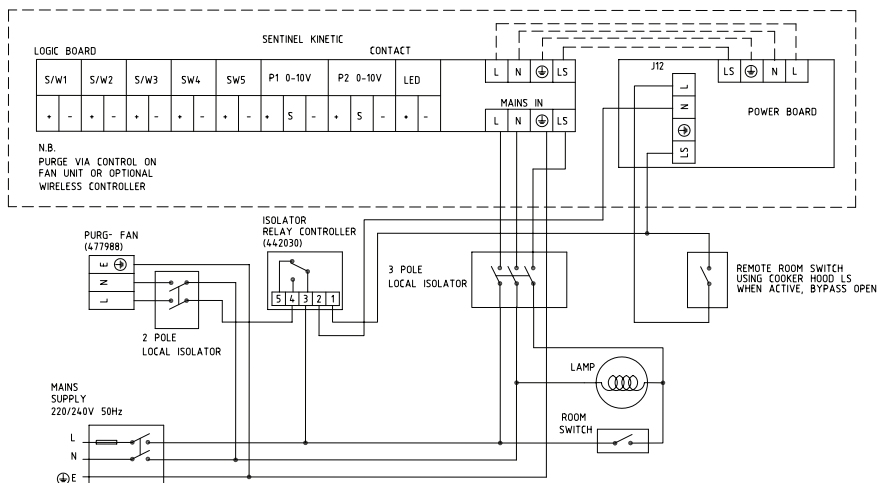









# Ducting & Fittings

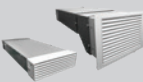

Since 1936, Vent-Axia has been known for providing a complete ventilation solution. This has not changed, and now we offer one of the widest ranges of ancillaries available today.

**Vent-Axia**

**Vent-Axia**  
**Lo-Carbon**  
**Approved**  
**Installer**

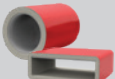
	Fan Fire Collar	F3-F4
	Pyrocheck Fire Airbricks	F5-F6
	Thermflow 200mm Ducting	F7-F8
	Uniflexplus+ RV Adjustable Valve	F9-F12
	Vent-Axia Pure Air	F13-F14
	Wholehouse Attenuators	F15-F16
	Universal Roof Vents	F17
	Pull-out System Hood	F18
	Uniflexplus+ Semi-Rigid Duct System	F19-F20
	Internal Fit Wall Kit	F21
	Low Resistance Inlet/Outlet Air Brick	F22
	Ducting & Accessories	F23-F30
	Galvanised Spiral Wound Ducting	F31
	100mm & 150mm Accessories	F32-F34
	Vent Duct Fire Sleeves	F35-F39
	Fire Rated Air Valves	F40

# Fan Fire Collars

- Fire Protection Solution for 100mm and 125mm fans
- Fire Tested to BS EN 1365-2 on a loaded floor
- 30 Minute Fire Rating
- Test evidence for use in Solid Timber, Metal Web Joists and engineered I-Beam floor/ceiling systems



Our Fan Fire collars are designed to provide fire protection for penetrations in floor/ceiling systems when combined with 100mm and 125mm ceiling fans. In the event of a fire, the product's intumescent lining expands to seal off the ceiling opening, creating an effective fire barrier, reinstating the ceiling's fire rating.

Recessed ceiling fans are commonly used in both residential and commercial buildings. However, cutting a hole in the ceiling for a fan compromises the structure's integrity and its fire performance. To restore the original fire rating of the ceiling/floor construction, it is essential to firestop the penetration as required by the Part F Building Regulations or Technical Handbook in Scotland

The Ceiling Fan Firestop features a steel mounting ring with an integral intumescent lining and duct connector. This assembly is fixed into the ceiling lining, allowing for normal installation of the ceiling fan. Compatible with a variety of 100mm and 125mm ceiling fans.

## Model

**Description**  
 100mm Fan Fire Collar  
 125mm Fan Fire Collar

**Stock Ref**  
**413702**  
**413703**

## Fitting Instructions

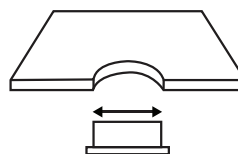

### Step 1

Cut a hole in the ceiling to match the outside diameter of the sleeve on the Ceiling Fan Firestop mounting ring.

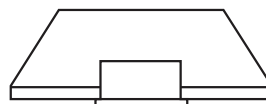

### Step 2

Push the Ceiling Fan Firestop mounting ring into the cut out aperture in the ceiling and fix through the collar using 4No. 3.5mm diameter by 42mm long drywall screws, to each of the pre drilled holes.



### Step 3

Ensure that the 2No. steel tabs are protruding towards the aperture within the collar, to prevent the duct sliding through the collar.

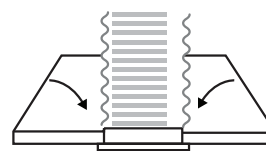

### Step 4

Install and fix the ceiling fan unit to the manufacturer's instructions, ensuring that the fan duct work spigot is centrally located within the firestop mounting ring.

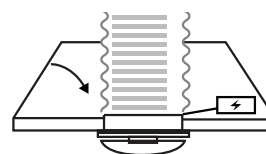

### Step 5

Connect the ductwork to the ceiling fan duct spigot and the electrical supply as recommended by the fan manufacturer's instructions.

Note: The Ceiling Fan Firestops are not tested or approved for use in walls or partitions.



Fire Performance and \*Assessment in accordance with BS EN 1365-2

Joist Construction	Ceiling construction with appropriate fire rating	Supply and extract Diameter in mm	Product Fire Classification Rating (minutes)			Report Reference
			Integrity (E)	Insulation (I)	Classification (EI)	
Mitek PS10+ Timber Chord with Metal Web Joist	1 x 15mm Siniat GTEC fire boards	100	30	30	30	Warringtonfire - WF394530
JJI Joists Solid Timber Chord with OSB Web Joist	1 x 15mm Siniat GTEC fire boards	100 and 125	30	30	30	Warringtonfire - WF422978
Solid Timber joists		100 and 125	30	30	30	
Mitek PS10+ PAR/20405/01 Timber Chord with Metal Web Joist	1 x 15mm Siniat GTEC fire board or 2 x 12.5mm Siniat GTEC fire boards	100 and 125	30	30	30	* International Fire Consultants- Mitek PS10+ PAR/20405/01
Timber I beams		100 and 125	30	30	30	

30 minute rated floors to be minimum 1 x 15mm or 2 x 12.5mm thick GTEC Fireline fire rated plasterboard on the underside or alternative plasterboard types that demonstrate performance in a system tested to BS EN 1365-2: 2014 for a minimum period of 30 minutes up to the load as tested.

**Floor construction to one of the following:**

Mitek Posi-Joist made from min. 47mm wide x 70mm high top and bottom flanges and galvanised steel web

Timber joists min. 225mm high x 45mm wide C24 grade timber

Timber 'I' Beams which have been tested successfully in a system to BS EN 1365-2 for a minimum of 30 minutes up to the load which has been tested

In all above cases the fan/ducting must not penetrate any element of the loadbearing floor system other than the plasterboard layer.

Minimum spacing from other ceiling penetrations must be 200mm.

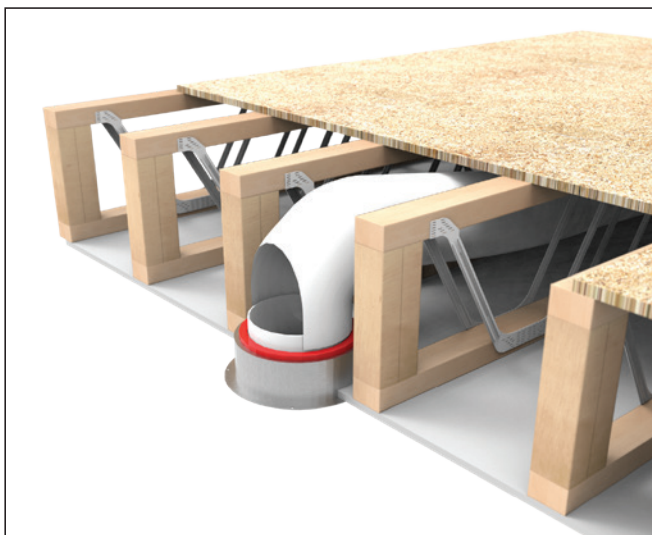

Ceiling Fan Firestop expands when exposed to heat.



**Note:** Vent-Axia does not guarantee compliance with Building Regulations Part B, Fire Spread or other regulations that relate to fire planning. Suitability to comply with these regulations should be determined prior to installation and in conjunction with Building Control Officers. Compliance with the Regulations is specifically excluded from quotations and designs. For further information, please contact our technical support department.

# Pyrocheck Fire Airbricks

- Compliant with Approved Document B
- Compliant with Building (Scotland) Technical Handbook 2019
- Designed for both 204x60 & 220x90 ducting
- Double and Single Airbrick Versions available in 5 RAL colours
- Bezelled version for exterior cladding, render or composite
- Corrosion resistance - salt spray tested to BS EN ISO 9227:2012
- Polyester Powder Coating EN13501-1 classification A2-s1,d0
- Performance tested to BS EN13141-2:2010
- Low resistance design to ensure high airflow
- Material 0.9mm electrogalvanized Sheet Steel, fire class A1



Fire ductwork improves the safe operation of ventilation systems by minimising the chance of fire spread.

A1 Fire metal ducting kits and fire airbricks manufactured in the UK to comply with the latest Part B regulations. Perfect for multi-storey developments which require all materials forming part of the external wall to be made from non-combustible materials.

Galvanised steel is considered fire class A1 without testing, as per European Commission paper 96/603/EC referred to in BS EN 13501-1:2018. The material remains robust at elevated temperatures and has a high melting point temperature of 1450-1520° C. Classification: A1. Definition: Non-combustible. Description: No contribution to fire.

- EN-13501-1:2018
- BS EN 13141-2:2010
- BS EN ISO 9227:2012 (Corrosion Resistance)
- CLASSIFICATION A2-S1; d0 (Powder Coating)
- A1 (Base Material)

## Models

### Fire Airbrick 204x60

Model	Colour	With Duct Stock Ref.	Without Duct Stock Ref.
Single Grille	White (RAL 9003)	412934	413682
Single Grille	Brown (RAL 8017)	412935	413683
Single Grille	Cotswold Stone (RAL 1001)	412936	413684
Single Grille	Grey (RAL 7037)	412937	413685
Single Grille	Terracotta (RAL 8004)	412938	413686
Single Grille Flanged	White (RAL 9003)	412944	413692
Single Grille Flanged	Brown (RAL 8017)	412945	413693
Single Grille Flanged	Cotswold Stone (RAL 1001)	412946	413694
Single Grille Flanged	Grey (RAL 7037)	412947	413695
Single Grille Flanged	Terracotta (RAL 8004)	412948	413696

### Fire Airbrick 220x90

Model	Colour	With Duct Stock Ref.	Without Duct Stock Ref.
Double Grille	White (RAL 9003)	412939	413687
Double Grille	Brown (RAL 8017)	412940	413688
Double Grille	Cotswold Stone (RAL 1001)	412941	413689
Double Grille	Grey (RAL 7037)	412942	413690
Double Grille	Terracotta (RAL 8004)	412943	413691
Double Grille Flanged	White (RAL 9003)	412949	413697
Double Grille Flanged	Brown (RAL 8017)	412950	413698
Double Grille Flanged	Cotswold Stone (RAL 1001)	412951	413699
Double Grille Flanged	Grey (RAL 7037)	412952	413700
Double Grille Flanged	Terracotta (RAL 8004)	412953	413701

# Performance



Volume (l/s)	15	35	50	65	85	100
Supply (Pa)	7	27	58	100	158	227
Exhaust (Pa)	5	19	42	71	109	152

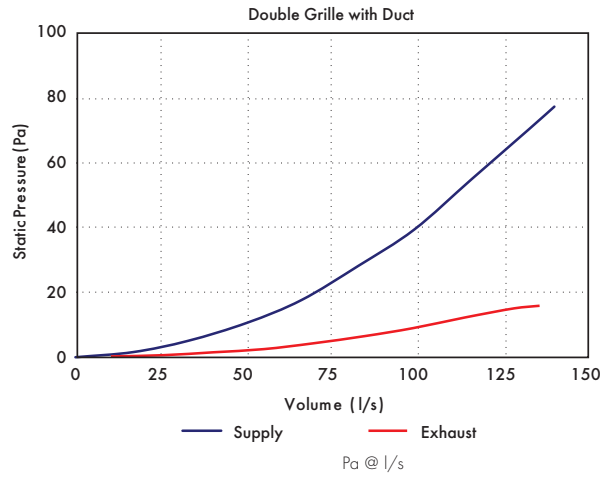

Volume (l/s)	15	35	50	65	85	100	115	130	140
Supply (Pa)	2	5	11	18	28	40	55	71	78
Exhaust (Pa)	0	1	2	4	6	9	12	15	16

# Dimensions (mm)

Single Grille with Duct

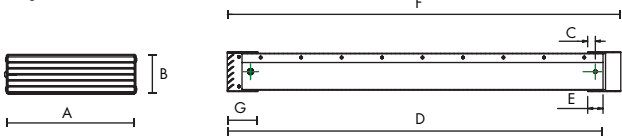

Double Grille with Duct

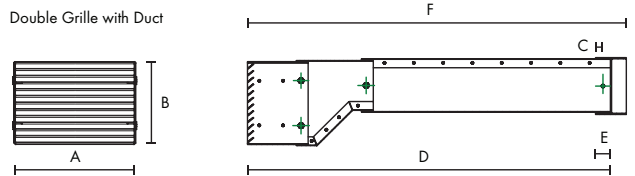

Model	Duct Size	A	B	C	D	E	F	G
Single Grille Flanged	204 x 60	245	90	12.5	613	25	640	50
Single Grille	204 x 60	210	65	12.5	613	25	640	50
Double Grille Flanged	220 x 90	245	165	12.5	613	25	640	-
Double Grille	220 x 90	210	140	12.5	613	25	640	-

# Thermflow 200mm Ducting

- Rigid lightweight 200mm ducting solution
- Outer case is shockproof and produced as CFC Free polyethylene (PE)
- Pre-Insulated polyolefin foam
- High thermal value achieving 0.038 W/(m·K)
- Quick and simple, airtight installation



## Thermflow 200mm Ducting

Innovative and sustainable insulated ventilation piping system developed to offer high-grade solutions to the increasing demands of comfort climate in residential buildings.

The Thermflow Rigid Range sets the standard for easy to install, pre-insulated ductwork. Quick and simple installation with minimum tools, tubes and bends are easily cut in a right-angle by following the channel of ridges.

Connections utilise rubber connectors ensuring a simple, air-tight, quick and secure installation.

Connections are flexible, absorb movement in the ducting system and therefore result in a tension free installation without resonance.

High thermal insulation value achieving 0.038 W/(m·K) with a closed cell structure and vapour tight barrier, preventing condensation forming. Insulated polyolefin foam is mechanically strong and water repellent, resulting in less dust pollution inside the ducting, it is also easy to clean. Manufactured sustainably without waste of raw materials, recycling directly for future batches with Cradle2Cradle certification.



## Technical

### Insulation Layer

Material	Polyolefin foam insulation
Structure	Closed cell structure, CFC free
Inner Diameter	200mm
Thermal Conductivity	0.038 W/m·K
Water Resistant Properties	Water repellent, vapour diffusion tight, no risk of corrosion, moss or mould forming
Chemical Constancy	Excellent
Indentation Resistance	Excellent

### Complete System

Fire Classification	SBI Euroclass E according to EN13501
Service Temperature Range	-40°C to +95°C
Noise compression through exterior case conforms to DIN-EN-ISO-5135-1999	TQ-Air 200/170mm 14 dB(A)
Recyclability	100%
Cradle to Cradle certification	Silver*

### Protection Casing

Material	Polyethylene
Structure	Corrugated, solid ring, dimensionally stable, mechanically strong and shockproof
Outer diameter	250mm
Scent	Neutral
Colour	Black



Models

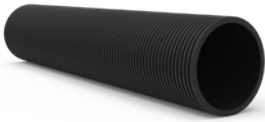

200mm Round 2m Length  
Duct Size  
Ø200mm

Stock Ref  
**413054**

Performance

	Pa	l/s
TQ-Air Flexalen HRV D250/200 Tube L2000	0.10	27.8
	0.20	55.6
	0.30	83.3
	0.80	111.1
	1.30	138.9
	1.80	166.7



200mm Round 90 Deg Bend  
Duct Size  
Ø200mm

Stock Ref  
**413055**

Performance

	Pa	l/s
TQ-Air Flexalen HRV D250/200 Bend 90°	0.20	27.8
	0.50	55.6
	1.00	83.3
	1.90	111.1
	3.10	138.9
	4.50	166.7



200mm Round 45 Deg Bend  
Duct Size  
Ø200mm

Stock Ref  
**413056**

Performance

	Pa	l/s
TQ-Air Flexalen HRV D250/200 Bend 45°	0.20	27.8
	0.50	55.6
	0.80	83.3
	1.40	111.1
	2.30	138.9
	3.40	166.7



200mm Round T-Piece  
Duct Size  
Ø200mm T-Piece

Stock Ref  
**413059**

Performance

	Pa	l/s
TQ-Air Flexalen HRV D250/200 T-Piece	2.50	27.8
	3.00	55.6
	5.00	83.3
	8.00	111.1
	12.50	138.9
	19.80	166.7



200mm Round Connector  
Duct Size  
Ø200mm

Stock Ref  
**413057**



250mm - 200mm Round Reducer  
Duct Size  
Ø200-250mm

Stock Ref  
**413058**

# Uniflexplus+ RV Adjustable Valve

- One valve for air supply and extraction: suitable for up to 21l/s
- Easy to adjust: 26 lockable positions for setting the air volume
- Excellent performance: the lowest noise and pressure drop values
- Same appearance for each volume of air: external dimensions stay the same irrespective of the selected setting
- Low turbulence airflows: prevents accumulation of dirt around the valve
- Flexible installation for all types of air ducts with connection Ø116 or Ø125
- Easy to clean: no need to remove the valve base
- Multiple designs available to suit various interior styles

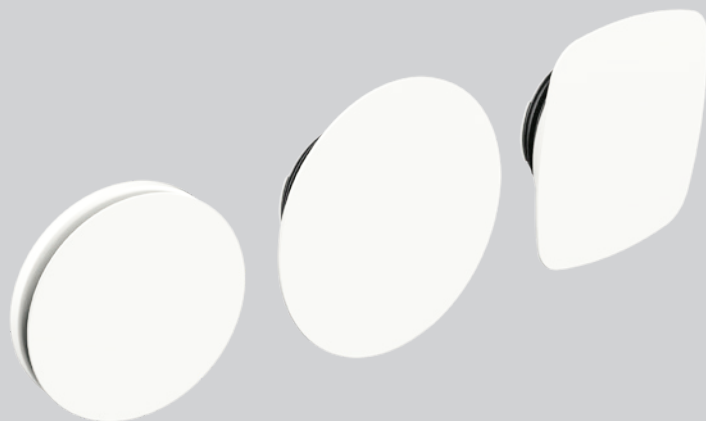

## Adjusting and locking

The Uniflexplus+ air distribution system has been designed to make installing and adjusting ventilation as quick and as easy as possible. With the Uniflexplus+ RV adjustable valve, the supply and extraction of air can be set and locked at fixed volumes in an instant.

The Uniflexplus+ RV is easy to install, even in suspended ceilings (with the aid of the special collar). The valve is also easy to maintain, as the base of the valve does not need to be removed from the ceiling. The air volume is adjusted entirely in the interior of the valve. This means that the external dimensions – and therefore the appearance – of the valves are always the same.

## Airtight and quiet

Uniflexplus+ is well known for its airtight connection without the use of mounting aids. Uniflexplus+ RV combines this with unique noise performance levels. Thanks to very low resistances, it is possible to meet the highest requirements in terms of comfort. If necessary, 120° of the supply/extraction opening can be blocked. In addition, the adjustable valve contains antistatic and antibacterial additives and is UV-resistant.

## Different versions

A great deal of attention has been devoted to the design of the adjustable valve and the materials used in it. It has an elegant appearance, with three different designs to suit various interior styles (RV 125, RVG 125 & RVV 125).

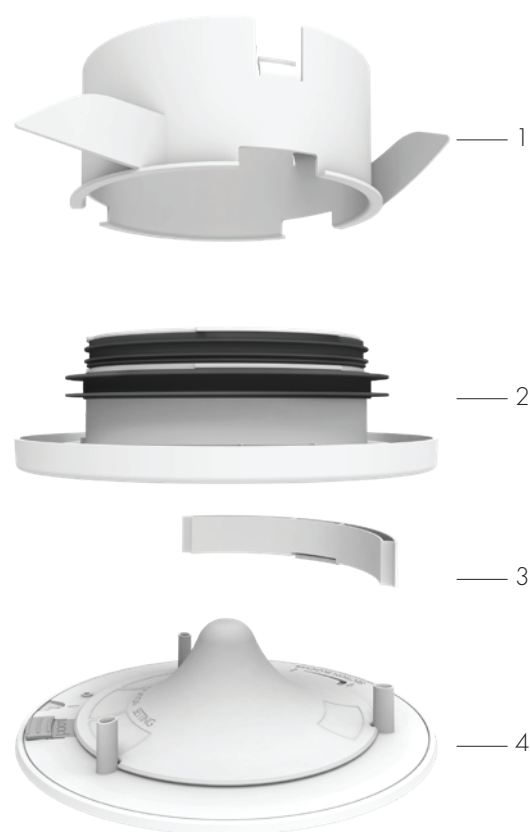

1. Collar (Accessory: RVK)
2. Base
3. Blanking plate (Accessory: RVB)
4. Regulating cone

## Models



Adjustable Round Valve  
Model  
RV 125



Adjustable Round Valve Large  
Model  
RVG 125



Adjustable Square Valve  
Model  
RVV 125

## Accessories



Stock Ref  
479372

Collar  
Model  
RVK

Stock Ref  
479376



Stock Ref  
479373

Blanking Plate\*  
Model  
RVB

Stock Ref  
479377

\*Not suitable for RVV 125 model

Stock Ref  
479374

## Specification

Model	Weight (g)	Colour	Material
RV 125	230	RAL 9003	ASA
RVG 125	410		ASA, powder-coated ALU
RVV 125	450		

## Dimensions (mm)

Front view  
RV 125 / RVG 125

RVV 125

Side view  
(Based on drawing of RV 125)

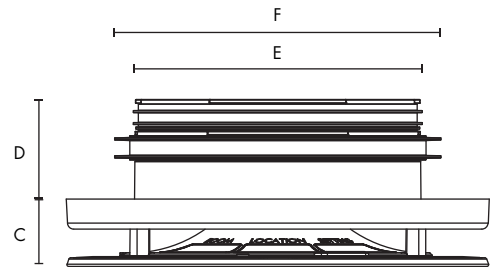
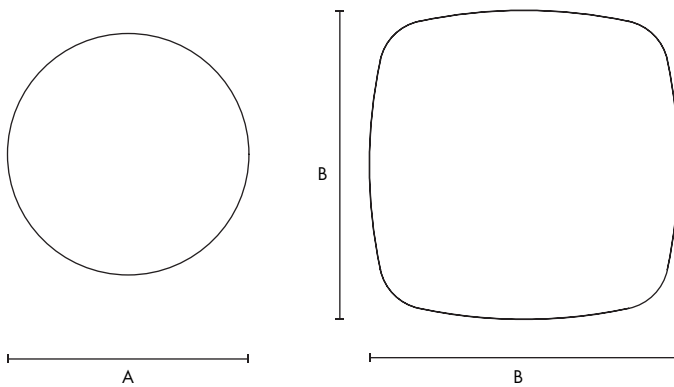

AØ	B	C	D	EØ	FØ
170/215	215	27	40	116	125

# Performance graph for Uniflexplus+ RV: Air supply

For each valve setting, the noise and pressure drop performance characteristics are shown in relation to the various air volumes.

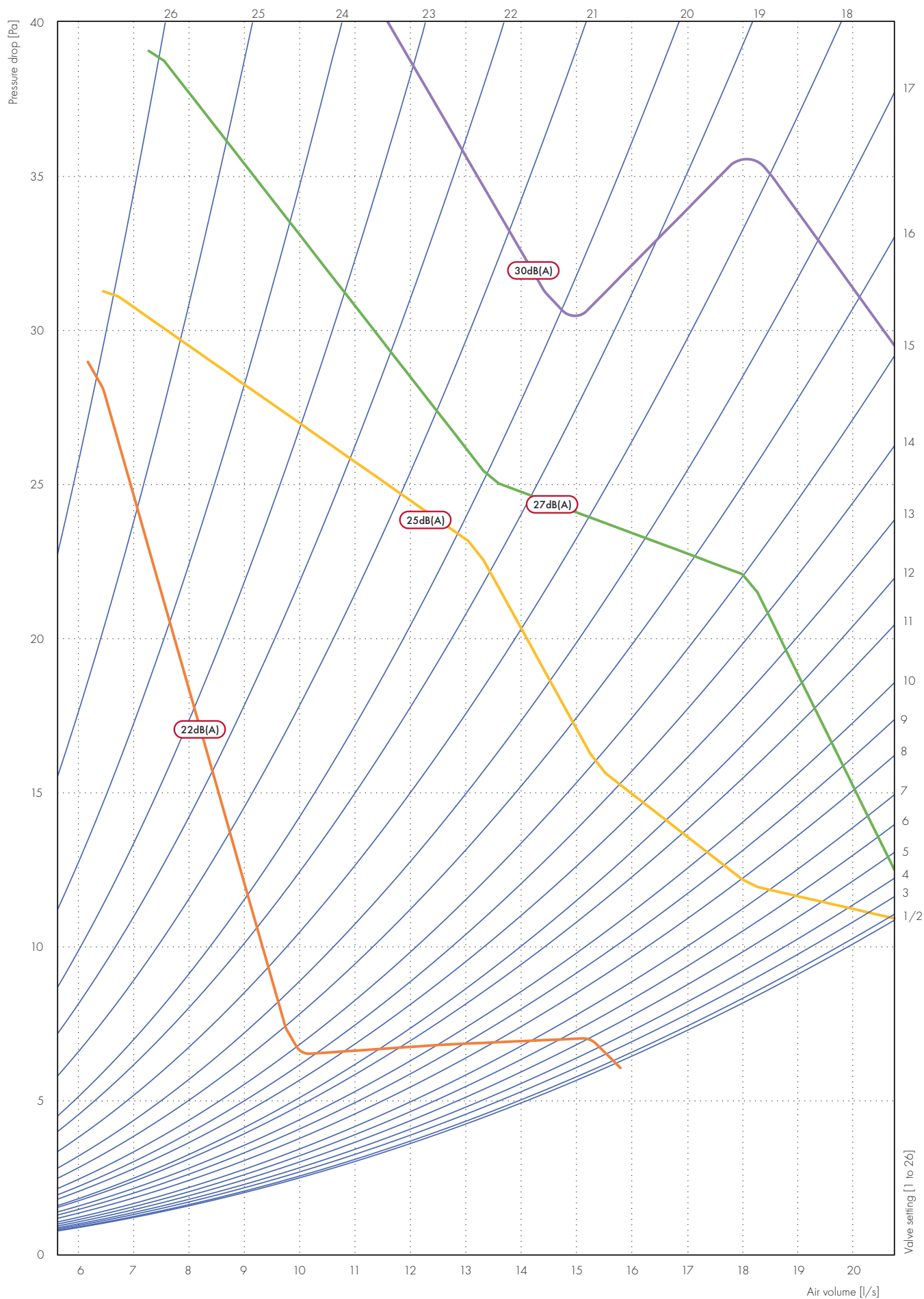

Tested in accordance with: EN ISO 5135:1999

# Performance graph for Uniflexplus+ RV: Air extraction

For each valve setting, the noise and pressure drop performance characteristics are shown in relation to the various air volumes.

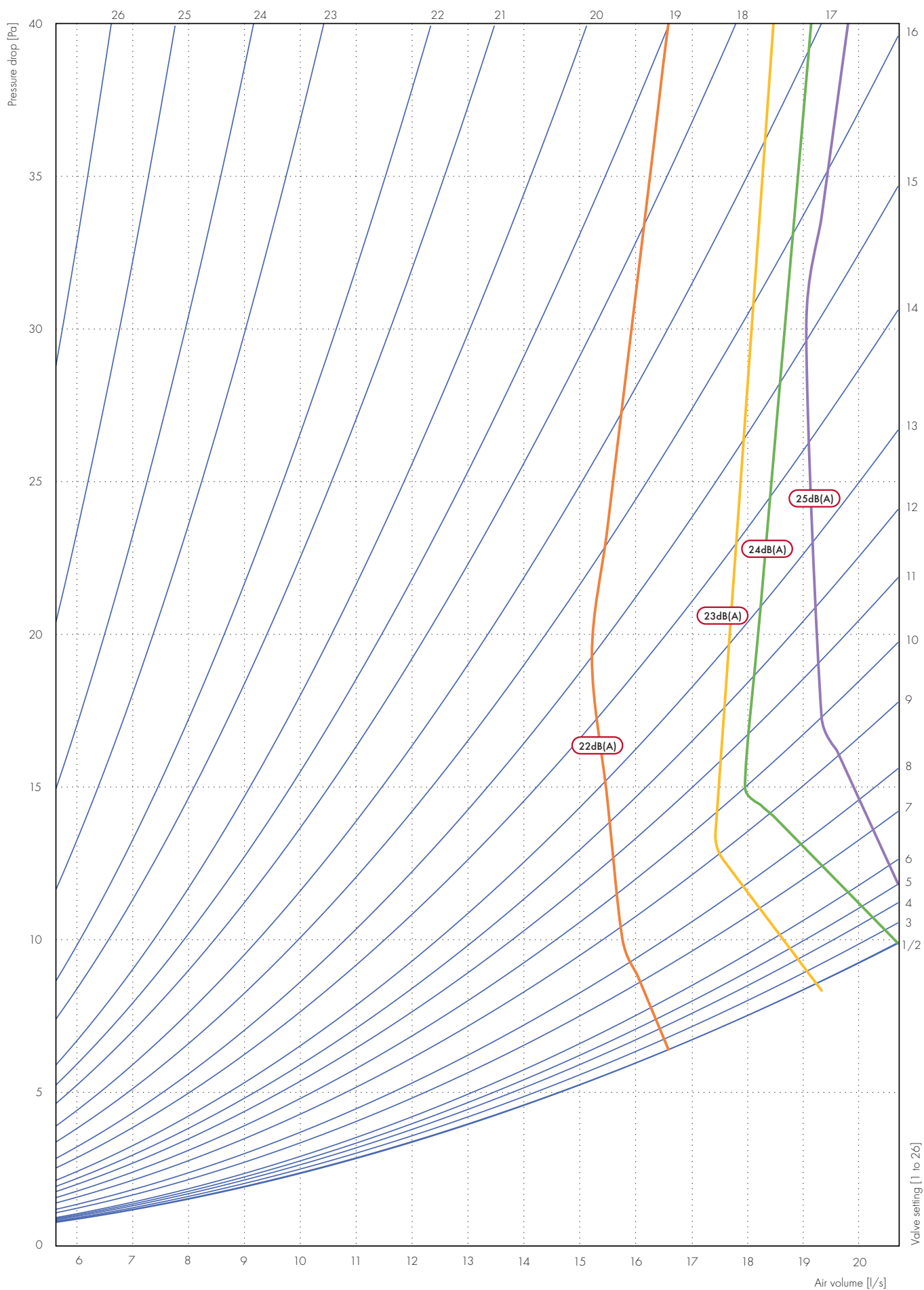

Tested in accordance with: EN ISO 5135:1999

# Vent-Axia Pure Air

- Removes NOX and other gases
- Removes particles down to PM2.5
- Offers multiple spigot options
- Low pressure drop
- Easy to install with mounting brackets
- Conforms to international air quality guideline limits
- Easy installation & maintenance
- Various sizes to suit residential or commercial applications
- Provides induct noise attenuation
- Insulating jackets available
- New compact unit available



## What is it?

The Vent-Axia Pure Air combines particulate and gas filters to remove pollutants prior to entering residences and commercial buildings through mechanical ventilation and heat recovery systems. The Vent-Axia Pure Air is designed to bring outdoor air pollutant levels within the guideline exposure limits as set out in the World Health Organisation Air Quality Guidelines and the CAFE Directive prior to entering an occupied space.

Indoor air quality (IAQ) is becoming increasingly important with properties being built in urban, industrialised areas. The Vent-Axia Pure Air offers a complete filtration solution with a range of specifiable products that meet planning obligations and refine traditional filtration, leaving home owners with confidence in their heat recovery systems.

## What does it do?

The Vent-Axia Pure Air sets the benchmark for high level filtration. It targets pollutants generated outside of the home, by traffic and industrial processes, and reduces these before supplying the air into the dwelling.

The Vent-Axia Pure Air filter is fitted to the intake airflow and incorporates two types of filtration:

- Enhanced activated Carbon which removes unpleasant odours and harmful gasses such as Nitrous Oxide (NO<sub>2</sub>).
- ISO 65% Coarse (G4) or ePM2.5 (F7) particulate filters which can remove tiny airborne contaminants such as pollen, bacteria and even PM2.5 diesel particulates.

The combination of MVHR and Vent-Axia Pure Air filtration offers the ideal indoor environment.

## Unit Specification

The Vent-Axia Pure Air is manufactured from 1.2mm Galvanised Steel together with suitable sealing for particulate and gas filters. Access is available on both sides via bolted lift off panels. Various round and rectangular transformation spigots are available to suit ductwork systems for both domestic and commercial duct work.

## Filter Specification

### Particulates, PM10, PM2.5

A new ISO filtration standard has come into force. The test method has changed so direct comparisons between EN779 2012 and ISO 16890 cannot be drawn. Below is a guide to the filter efficiencies:

ISO 16890	EN779
45% Coarse	G3
65% Coarse	G4
ePM10 50%	M5
ePM2.5 70%	F7

### Pollutant Gases, NO<sub>2</sub>, SO<sub>2</sub>, O<sub>3</sub>, VOC

The gas stage filters in the Vent-Axia Pure Air are designed to achieve a minimum contact time suitable for the removal of pollutant gases at the rated airflow. A specially formulated activated carbon and chemical mix acts upon pollutant concentrations common in dirty city air, reducing them below guidelines set by current legislation.

## Unit Configuration

Standard Gas Filter Unit

Replaceable ePM2.5 or ePM10 Filters

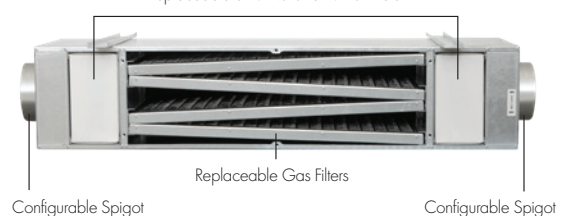

Compact Gas Filter Unit

Replaceable Gas Filters



## Accessories

### Model

Single spare ePM2.5 filter  
 Single spare ePM10 filter  
 Single spare gas filter

Stock Ref  
**PAFIL-25**  
**PAFIL-10**  
**PAFIL-NO2**

## Models

Model Range	Stock Ref	Airflow l/s	Intake Spigot (mm)*	Exhaust Spigot (mm)*	Filter Types	Clean Filter Pressure Drop (Pa)	Approximate Unit Weight (kg)
Standard Gas Filter Unit	PA50-125125-25	50	125Ø	125Ø	PM2.5 x 2-off & NO <sub>2</sub> x 4-off	100	25
	PA50-125204-25	50	125Ø	204x60	PM2.5 x 2-off & NO <sub>2</sub> x 4-off	100	25
	PA50-204204-25	50	204x60	204x60	PM2.5 x 2-off & NO <sub>2</sub> x 4-off	100	25
	PA50-125125-10	50	125Ø	125Ø	PM10 x 2-off & NO <sub>2</sub> x 4-off	45	25
	PA50-125204-10	50	125Ø	204x60	PM10 x 2-off & NO <sub>2</sub> x 4-off	45	25
	PA50-204204-10	50	204x60	204x60	PM10 x 2-off & NO <sub>2</sub> x 4-off	45	25
	PA100-150150-25	100	150Ø	150Ø	PM2.5 x 4-off & NO <sub>2</sub> x 8-off	100	49
	PA100-150220-25	100	150Ø	220x90	PM2.5 x 4-off & NO <sub>2</sub> x 8-off	100	49
	PA100-220220-25	100	220x90	220x90	PM2.5 x 4-off & NO <sub>2</sub> x 8-off	100	49
	PA100-150150-10	100	150Ø	150Ø	PM10 x 4-off & NO <sub>2</sub> x 8-off	45	49
	PA100-150220-10	100	150Ø	220x90	PM10 x 4-off & NO <sub>2</sub> x 8-off	45	49
	PA100-220220-10	100	220x90	220x90	PM10 x 4-off & NO <sub>2</sub> x 8-off	45	49
	PA200-200200-10	200	200Ø	200Ø	PM10 x 8-off & NO <sub>2</sub> x 16-off	45	96
PA200-250250-10	200	250Ø	250Ø	PM10 x 8-off & NO <sub>2</sub> x 16-off	45	96	
PA300-315315-10	300	315Ø	315Ø	PM10 x 12-off & NO <sub>2</sub> x 24-off	45	144	
Compact Gas Filter Unit	PAC50-125	50	125Ø	125Ø	NO <sub>2</sub> x 4-off	45	23
	PAC50-150	50	150Ø	150Ø	NO <sub>2</sub> x 4-off	45	23
	PAC50-204	50	204x60	204x60	NO <sub>2</sub> x 4-off	45	23
	PAC50-220	50	220x90	220x90	NO <sub>2</sub> x 4-off	45	23
	PAC100-125	100	125Ø	125Ø	NO <sub>2</sub> x 8-off	45	45
	PAC100-150	100	150Ø	150Ø	NO <sub>2</sub> x 8-off	45	45
	PAC100-204	100	204x60	204x60	NO <sub>2</sub> x 8-off	45	45
	PAC100-220	100	220x90	220x90	NO <sub>2</sub> x 8-off	45	45

\*Airflow may be reversed through the unit to offer alternative spigot options.

Example Stock Ref:

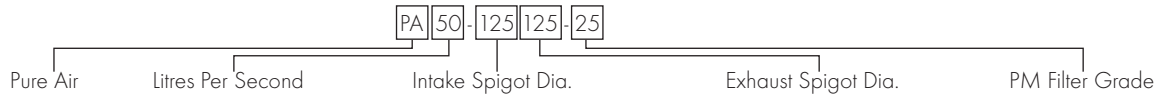

## Dimensions (mm)

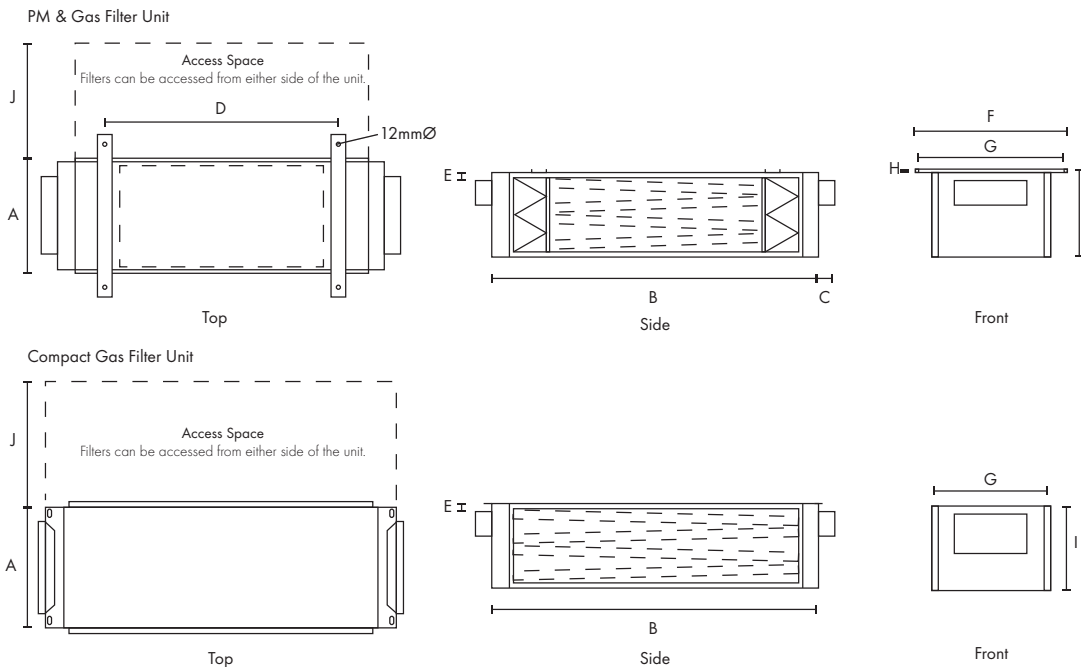

Model Range	Airflow l/s	A	B	C	D	E	F	G	H	I	J
Standard Gas Filter Unit	50	320	980	50	700	25	435	405	10	220	325
	100	620	980	50	700	25	730	700	10	220	325
	200	620	980	50	700	110/85	730	700	10	420	650
	300	620	980	50	700	160	730	700	10	630	960
Compact Gas Filter Unit	50	320	690	-	-	25	-	260	-	180	325
	100	620	690	-	-	25	-	560	-	180	325



# Wholehouse Attenuators

- Reduces induct noise
- Variety of sizes to suit specified noise requirements
- Compatible with both 204x60mm<sup>2</sup> and 220x90mm<sup>2</sup> rectangular ductwork
- Central and offset spigot options to suit each installation
- Rigid galvanized steel construction
- Easy installation
- Suitable for almost any ventilation system
- Low pressure loss



The Vent-Axia Wholehouse Attenuator has been developed to reduce induct noise in both residential and commercial ducting systems.

## Technical Details

The Wholehouse Attenuator is compatible with either 204x60mm<sup>2</sup> or 220x90mm<sup>2</sup> ducting. It also offers two spigot options to suit the installation and design requirements. The Wholehouse Attenuator is available with either a standard centralised spigot or, for instances when the ducting is installed flat to a concrete slab, an offset spigot. As well as saving the need for additional ducting components, this allows for a much easier and quicker installation.

## Noise Reduction

Offering excellent sound reduction over a range of frequencies, the Wholehouse Attenuator is available in two lengths depending on the noise suppression requirements. For MVHR systems the attenuator can be fitted on the supply side to habitable rooms, reducing airborne in-duct noise. For MVHR and extract-only systems, the attenuator may be placed on the extract side to limit 'crosstalk' through ductwork between rooms.

## Models

### Attenuator with Central Spigot

Model	Stock Ref
204x60 Duct 620mm Length	477369
204x60 Duct 920mm Length	407915A
204x60 Duct 1220mm Length	407916A
220x90 Duct 620mm Length	477370
220x90 Duct 920mm Length	407920A
220x90 Duct 1220mm Length	407921A

### Attenuator with Offset Spigot

Model	Stock Ref
204x60 Duct 620mm Length	477371
204x60 Duct 920mm Length	475427
204x60 Duct 1220 Length	475428
220x90 Duct 620mm Length	477372
220x90 Duct 920mm Length	475429
220x90 Duct 1220mm Length	475430

### Acoustic Flexible Ducting

Model	Stock Ref
125mmØ Duct 1m Length	443793
150mmØ Duct 1m Length	443274

## Dimensions (mm)

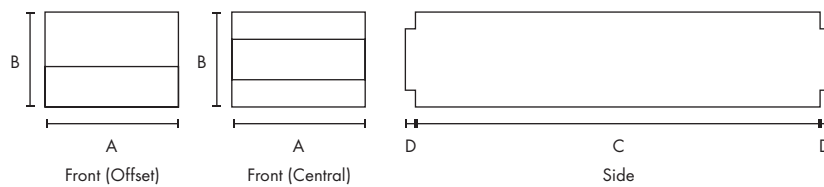

Model	Stock Ref	A	B	C	D	kg
204x60 Duct 620mm Length	477369/477371	196	125	620	50	10
204x60 Duct 920mm Length	407915/ 475427	200	120	920	50	13
204x60 Duct 1220mm Length	407916/475428	200	120	1220	50	17
220x90 Duct 620mm Length	477370/477372	207	148	620	50	10
220x90 Duct 920mm Length	407920/ 475429	210	145	920	50	14
220x90 Duct 1220mm Length	407921/475430	210	145	1220	50	17

## Acoustic Performance

Model	Stock Ref	Insertion Loss (dB)							
		63	125	250	500	1k	2k	4k	8k
204x60 Duct 620mm Length/ 220x90 Duct 620mm Length	477369/477370/ 477371/477372	3	4	7	13	21	38	45	33
204x60 Duct 920mm Length	407915/475427	0.3	3.2	11.6	24.2	38	49.1	50.3	36.4
204x60 Duct 1220mm Length	407916/475428	0.3	1.8	14.1	21.3	35.4	46.9	50.4	36.4
220x90 Duct 920mm Length	407920/475429	7.3	10.2	13.1	26.2	34.9	47.6	52.2	38.9
220x90 Duct 1220mm Length	407921/475430	1.2	7.4	18.6	30.2	39.1	51	45.2	38.6
125mmØ Duct 1m Length	443793	5.5	11.5	17	19.9	19.1	25.6	20	21.6
150mmØ Flexible Duct 1m Length	443274	-1.2	10.6	19	16.8	15.7	22.2	15.7	17.6

## Pressure Loss

Model	Duct Size (mm)	Volume (l/s)	Pressure Loss (Pa)
Attenuator	204x60	15	6
		30	10
		60	25
		80	41
Attenuator	220x90	15	6
		30	10
		60	22
		80	36
Acoustic Flexible Ducting (1m)	125	15	2.8
		30	8.8
		60	19.2
		80	37.5
Acoustic Flexible Ducting (1m)	150	15	1.7
		30	6.4
		60	13.8
		80	28.4

# Universal Roof Vents

- Models available for both pitched and flat roof types
- Complies with Building Regulations
- Suitable for most installations
- Corrosion resistant and weather proof
- Compatible with both mechanical and natural ventilation systems
- Three colours available for pitched roof vents

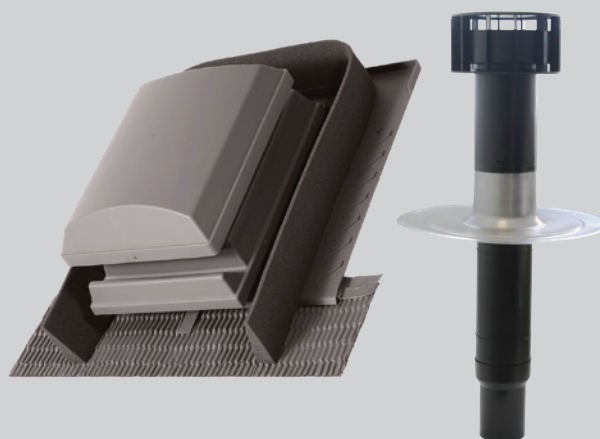

Wholehouse ventilation systems require termination to the external atmosphere, often through the roof. To ensure that the ventilation system is able to achieve its optimum level of performance, it is important that a suitable roof termination product is installed.

With this in mind, Vent-Axia is pleased to offer a range of Universal Roof Vents; including products suitable for both pitched and flat roof types.

A selection of colours and sizes should ensure that our range offers a product suitable for most residential applications with a pitched or flat roof. Pitched roof vents are available in a variety of colours as detailed in the Specification Table - custom colour and textured vents to match your exact needs are also available at an extra charge. Please contact our Technical Support team for more details.

## Models

### Universal Roof Vent suitable for Pitched Roofs

Manufactured in the UK, these products have been specifically developed for use with both natural and mechanical ventilation systems.

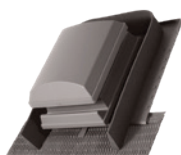

All models have been independently tested by the BRE to BS476 Part 3: 2004 and have been awarded an AA classification - the highest possible. Thus they can be installed without restriction on any pitched roof.

All models have low resistances to airflow (see table) and incorporate condensation grooves to prevent any condensate running back down the duct. Universal Roof Vents are designed to resist the ingress of deluge and driving rain. Universal Roof Vents (pitched roof models) are suitable for roof pitches between 20° and 60°.

The pitched roof vents are available as a 'tiled' roof vent to fit alongside most traditional roof tiles, as well as a 'slate' version which can be easily cut down to fit alongside all traditional roof slates.

Stock Ref	Tile Type	Spigot mm	Colour	Airflow Resistance (Pa) at l/s				
				14	28	56	83	140
407329	Universal*	125	Red	1.1	4.1	16.8	N/A	N/A
407330	Universal*	125	Brown	1.1	4.1	16.8	N/A	N/A
407331	Universal*	125	Grey	1.1	4.1	16.8	N/A	N/A
407332	Universal*	150	Red	0.3	1.0	4.2	9.5	27.4
407333	Universal*	150	Brown	0.3	1.0	4.2	9.5	27.4
407334	Universal*	150	Grey	0.3	1.0	4.2	9.5	27.4
407335	Slate	125	Slate Blue/Black	1.1	4.1	16.8	N/A	N/A
407336	Slate	150	Slate Blue/Black	0.3	1.0	4.2	9.5	27.4

\*Universal Roof Vents are not suitable for the following tile types: Plain, Clay Single Pantiles, Forticrete Centurion, Goxhill Gaelic Tiles, Double Lap or Interlocking Slates. If the Universal Roof Vent does not meet your requirements, please contact our Technical Support team for a bespoke solution

### Universal Roof Vent suitable for Flat Roofs

Capped stacks for use in asphalt and built-up felt roofs. Special low air resistance cowl - the pressure/airflow resistance is <1.0 Pascal at 63l/s. The pipework above the roofline is twin walled and incorporates an integral condensation drain. The stack pipe has an integral collar and separate aluminium flange for use with both felt and asphalt roof finishes.



All Vent-Axia Universal Roof Vents have a free area exceeding those required by Building Regulations.

Stock Ref	Colour	Free Vent Area mm <sup>2</sup>	Pressure/Airflow Resistance	Dia. mm	Height Above Roof mm	Flange Dia. mm	Depth Below Flange mm
407337	Black	8,400	<1.0	110	300	395	350
407338	Black	12,000	<1.0	131	400	450	350
407339	Black	20,000	<1.0	166	540	450	510

# Pull-out System Hood SELV

- Models available with either a White or Brushed Aluminium trim
- Fits within a 600mm wide aperture (300mm deep)
- Complete with two low energy 9W lamps
- All models are fitted with a metal washable grease filter as standard
- 125mm galvanised duct connection piece
- Integral fire damper in accordance with BRE 398
- Weight: 3.7kg
- SELV hoods allow the distance between the hood and an electric hob to be reduced from 650mm to 550mm



## Product

The Pull-out System Hood is designed to fit in a 600mm aperture above a hob. The telescopic hood incorporates two flat removable metal grease filters, two low energy light bulbs and is available with a White or Brushed Aluminium front trim.

The hood contains an integral fire damper in accordance with BRE Digest 398 and is connected to the mechanical ventilation unit by a galvanised steel duct connection piece. When the hood is opened the mechanical ventilation unit goes to boost speed.

## Why install a cooker hood?

Steam created during the cooking process can cause moisture to form on walls and furniture. In extreme cases this can lead to mould growth. Strong smells can also be created during cooking and these can spread throughout the dwelling. Cooking oils may be vaporised when frying and this oil can be deposited in areas around the cooker.

## The solution

When connected to an MEV or MVHR system, the Pull-out System Hood can be wired in such a way that when the hood part of the unit is pulled out the MEV or MVHR system will automatically switch to boost.

The Pull-out Hood System Hood comes with an integrated 125mm galvanised spigot to allow for connection to the MEV or MVHR system.

SELV hoods allow the distance between the hood and an electric hob to be reduced from 650mm to 550mm.

## Models

Model	Stock ref
White SELV	474790
Aluminium SELV	474791

## Dimensions (mm)

TOP

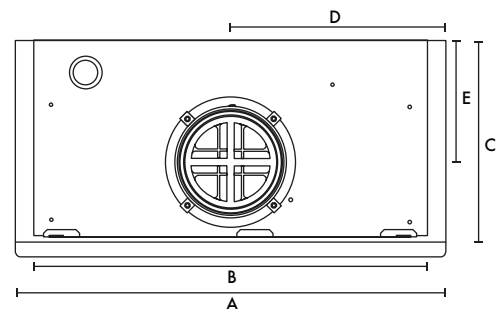

SIDE

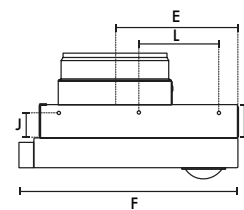

FRONT

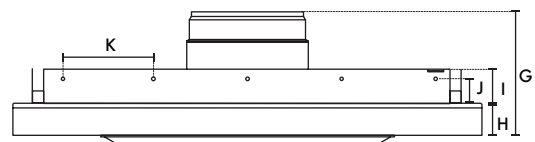

A	B	C	D	E	F	G	H	I	J	K	L
598	570	280	299	126	300	158	41	50	40	120	110

# Uniflexplus+ Semi-Rigid Duct System

- Compact, low profile system
- Highly flexible and robust
- Extremely crush resistant
- Quick and easy to install
- PCDB listed
- Suitable for installation in concrete
- Corrosion resistant
- Smooth inner surface with antistatic and antibacterial coating
- Independently tested and accredited for air tightness
- Class D air tightness
- Operating temp.: -20°C to +60°C
- A spigot blanking cap is provided for use with single runs of semi-rigid

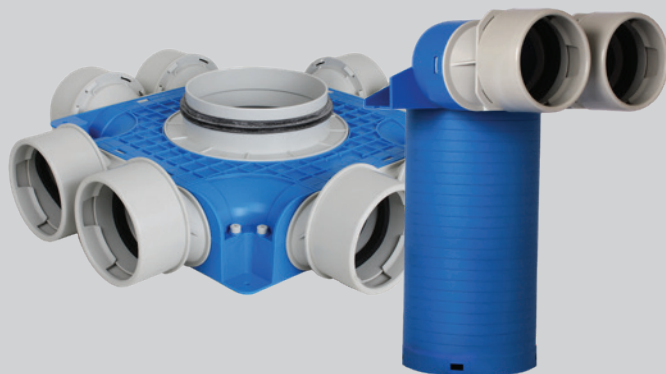

## Uniflexplus+ Semi-Rigid Range

The new Uniflexplus+ Semi-Rigid Range sets the standard for easy to install, low profile ducting solutions. The system gives all of the flexibility that semi-rigid ducting provides - without taking up vital space. With minimal components, the system is uncomplicated to ensure a hassle-free, speedy install.

The Uniflexplus+ Semi-Rigid Range is compatible with most wholehouse ventilation systems including the Lo-Carbon Sentinel Kinetic Range (MVHR).

### Accessories

Description	Duct Size	Stock Ref
Circular Extract Diffusers	125mmØ	10544125
Duct Knife	Ø90mm	472252
90° Bend	Ø90mm	472253
Coupler	Ø90mm	472254

Description	Model	Duct Size	Stock Ref
Adjustable Round Valve	RV125	125mmØ	479372
Adjustable Round Valve Large	RVG125	125mmØ	479373
Adjustable Square Valve	RVV125	125mmØ	479374
Adjustable Valve Collar	RVK	125mmØ	479376
Adjustable Valve Blanking Plate*	RVB	125mmØ	479377

\*Not suitable for RVV125 model

### Complete System Setup Examples

The distribution boxes can be mounted vertically on a wall or fixed horizontally onto a ceiling slab to achieve a solution tailored to your need. At a depth of just 90mm, the distribution boxes offer a considerably low-profile solution - they can then be combined with various components to suit on-site needs.

Semi-Rigid ducting is run from distribution boxes and ancillaries to respective rooms in the dwelling. Connecting the Semi-Rigid ducting to components is exceptionally straightforward to allow speedy installation - simply turn the ducting into the spigot until it clicks twice to achieve an airtight mechanical seal.

Rigid or flexible 125mm diameter ducting is then run from the MVHR unit to the distribution box.

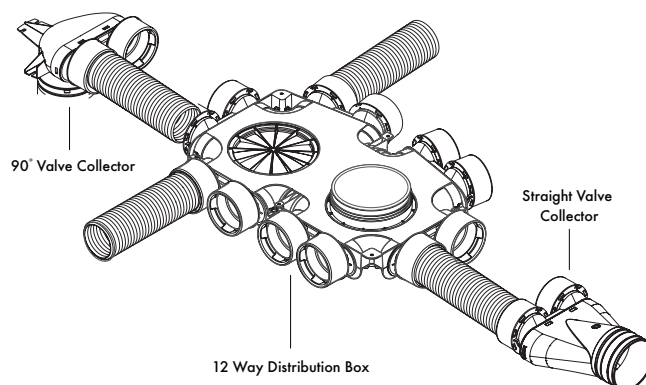
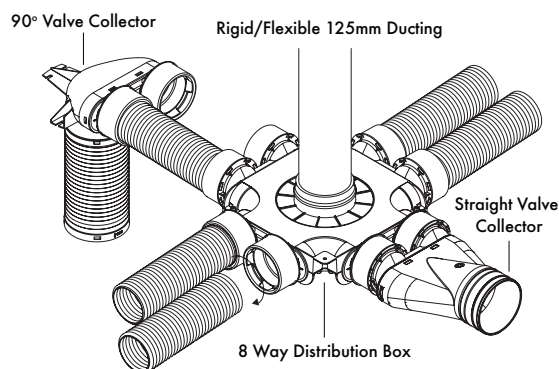

## Models

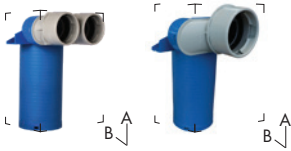

### 90° Valve Collector

The 90° Valve Collector connects a section of 125mm diameter ducting and turns 90° into 1 or 2 spigots to connect to the semi-rigid - ideal for dropping semi-rigid into ceiling diffusers.

Duct Size	Stock Ref
2xØ90 - Ø125mm	<b>472248</b>
1xØ90 - Ø125mm	<b>472249</b>

### Dimensions (mm)

Stock Ref	Curve Ref	A	B	kg
472248				0.9
472249	1	376	300	0.8

### Performance

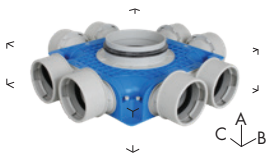
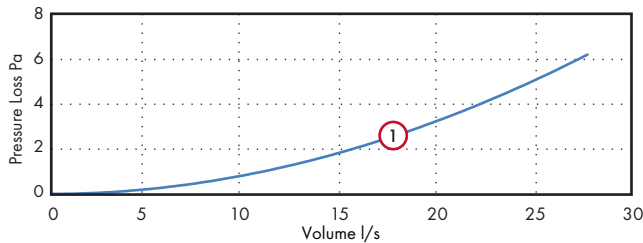

### Distribution Box

The low-profile distribution box runs a central spigot of diameter 125mm into a set of either 8 or 12 sub-spigots, depending on requirements. Available with 90mm semi-rigid spigots.

Model	Stock Ref
12xØ90 - Ø125mm	<b>472250</b>
8xØ90 - Ø125mm	<b>472251</b>

### Dimensions (mm)

Stock Ref	Curve Ref	A	B	C	kg
472250	1	124	755	520	3.9
472251	2	125	479	479	2.3

### Performance

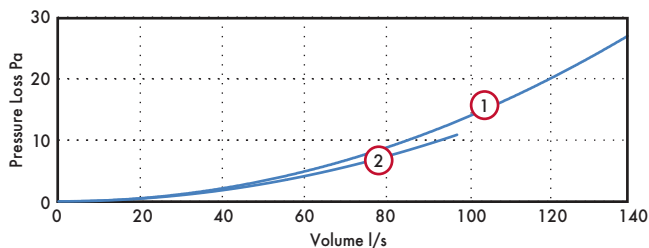

### Straight Valve Collector

The straight valve collector takes 125mm ducting and turns it straight into 2 spigots to connect to semi-rigid.

Model	Stock Ref
2xØ90mm - Ø125mm	<b>472262</b>

### Dimensions (mm)

Stock Ref	A	B	C
472262	123	311	229



### Semi-Rigid Ducting

Suitable for installation in concrete ceilings, suspended ceilings, internal walls, risers or frames, the Semi-Rigid Ducting is double-walled providing optimum flexibility. With an antistatic and antibacterial coating, the internal surface of the Semi-Rigid Ducting is smooth to ensure minimal resistance to airflow. Normally flammable construction material class E, according to EN-13501-1.

Pipe Size	Stock Ref
90mmØ x 50m	<b>406588</b>
90mmØ x 25m	<b>474078</b>

### Dimensions (mm)

Stock Ref	Curve Ref	O/I Ømm	Length m	Coil Ømm	Coil Height mm	kg
406588	1	90/78	50	1130	250	19.5
474078	-	90/78	25	1130	125	9.8

### Performance

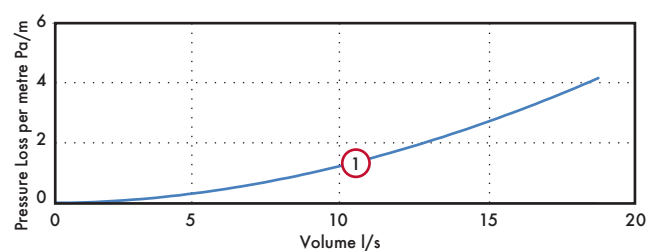

# Internal Fit Wall Kit

- Ideal for high-rise applications
- Suitable for 100mm fans
- Quick & easy installation
- Extendable length
- Fits from inside the property
- Reduces water ingress
- Includes low-resistance external grille
- Suitable as a passive air grille
- Covers external break-out

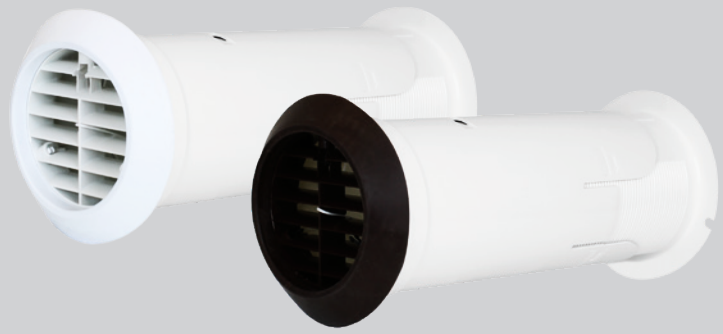

## Internal Fit Wall Kit

The Internal Fit Wall Kit is designed to simplify installation and improve the finish of 100mm through the wall installations, also providing an external grille and water ingress protection shroud.

## High Rise Buildings

The Wall Kit can be fully installed from inside the building, avoiding the need for scaffolding and significantly reducing the cost and complexity associated with these sites. After core-drilling a 117mm hole, or utilising an appropriate existing hole, the Kit simply pushes through from the inside of the building. Spring pins secure the external grille in position and the external shroud deploys around the grille covering up break-out from the external surface.

## Installer Friendly

Quick and easy to install, the Internal Fit Wall Kit cuts down time on site when compared to traditional methods using flexi-duct. Installers no longer need to spend time fixing flexi-duct to fans and grilles using jubilee clips, or going outside to fit the grille. The tubes extend to accommodate wall thicknesses from 225mm up to 390mm and lock into position for a secure fit. The internal flange is also flexible enough to accommodate deviations in the internal surface finish.

## Building Regulations

The external grille free area is greater than 90% of the area of the duct making it suitable for continuous running systems as well as for intermittent fans.

## Backdraught Shutter

The Internal Fit Wall Kit has optional backdraught shutter models. Particularly useful with intermittent fans, the backdraught shutter will ensure no draughts and gusts come in to the home through the wall kit.

## Models

Model	Stock Ref
White External Grille	472318
Brown External Grille	472319
White External Grille with Backdraught Shutter	474779

## Dimensions (mm)

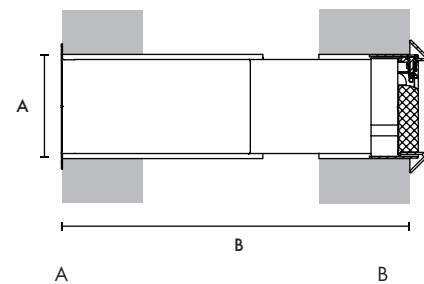

117mmØ                      225-390mm

## Features

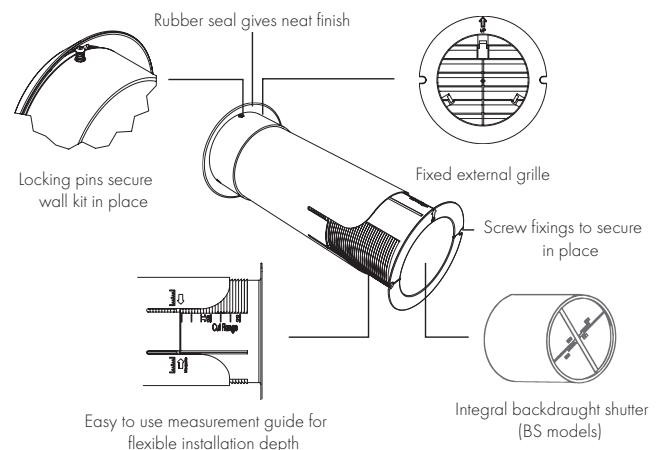



# Low Resistance Inlet/Outlet Air Brick

- Provides over 90% free area of duct
- Easier to install than a double air brick
- Guide vanes for improved duct connection
- Optional first fix duct section



Available in five colours, this low resistance air brick has been designed to comply with the latest Building Regulations Approved Document F, which requires a ventilation outlet to achieve a minimum of 90% of the cross sectional area of the ductwork.

Installing a single air brick is much simpler than a double air brick and offers more versatility for locations.

Suitable for installation with round 100mm and 125mm diameter and rectangular 204 x 60mm ducting.

Attaching duct to the air brick is simplified by the use of guide vanes which help locate the duct onto the spigot.

A 500mm section of 204 x 60 duct is available for first fix which ensures that connections are accessible after completion of building works.

Five colour options ensure that the low resistance air brick will be a match for almost any application.

## Models

Model	Stock Ref
White	449223
Brown	449224
Cotswold Stone	449225
Grey	449226
Terracotta	449227
1st Fix duct section	403255

500 x 204 x 60

## Available Colours



## Performance Guide

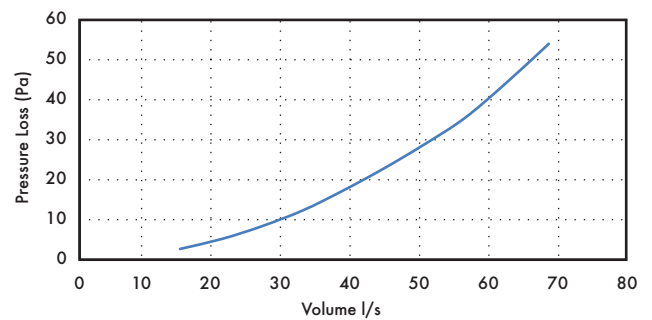

Pressure (Pa)	Volume (m <sup>3</sup> /h)	Volume (l/s)
2.7	53.7	14.9
5.2	75.9	21.1
8.3	97.0	26.9
12.4	119.4	33.2
17.4	141.0	39.2
22.7	162.0	45.0
28.7	183.7	51.0
35.4	205.6	57.1
44.1	227.6	63.2
54.0	250.4	69.6

## Dimensions (mm)

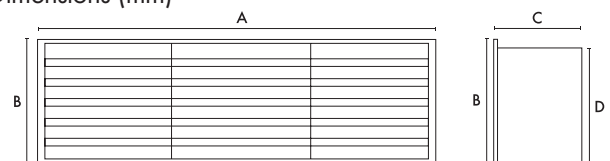

A	B	C	D
212	67	58	65

# Ducting & Accessories

## Flat Channel Ducting Insulated/Uninsulated

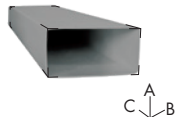

Stock Ref	Duct Size	External Dimensions (mm)			Resistance (Pa) at flow rate								
		A	B	C	8 l/s	13 l/s	21 l/s	29 l/s	37 l/s	45 l/s	53 l/s	61 l/s	
<b>433944</b>	Uninsulated 110 x 54 x 2m	54	110	2000	-	-	-	-	-	-	-	-	-
<b>436599</b>	Uninsulated 110 x 54 x 1.5m	54	110	1500	1.2	2.4	5.3	9.1	13.9	19.8	25.9	32	
<b>496156</b>	Uninsulated 204 x 60 x 1m	60	204	1000	<1	<1	<1	1.5	2.2	3.0	3.9	5.1	
<b>436617</b>	Uninsulated 204 x 60 x 1.5m	60	204	1500	<1	<1	1.3	2.2	3.3	4.5	5.9	7.8	
<b>406870<sup>(a)</sup></b>	Insulated 204 x 60 x 1.5m	210	354	1500	<1	<1	1.3	2.2	3.3	4.5	5.9	7.8	
<b>496160<sup>(a)</sup></b>	Insulated Sleeve 204 x 60 x 2m	210	354	2000	-	-	-	-	-	-	-	-	-
<b>496161<sup>(a)</sup></b>	Insulated 204 x 60 x 2m	210	354	2000	-	-	-	-	-	-	-	-	-
<b>474677</b>	Uninsulated 204 x 60 x 2m	60	204	2000	<1	<1	1.7	2.9	4.3	5.9	7.7	10.4	
Stock Ref	Duct Size	A	B	C	60 l/s			120 l/s			180 l/s		
<b>496157</b>	Uninsulated 220 x 90 x 1m	90	220	1000	0.9			3.2			6.7		
<b>407343<sup>(a)</sup></b>	Insulated 220 x 90 x 1.5m	240	370	1500	1.4			4.9			10.2		
<b>403025</b>	Uninsulated 220 x 90 x 1.5m	90	220	1500	1.4			4.9			10.2		
<b>474678</b>	Uninsulated 220 x 90 x 2m	90	220	2000	1.9			2.6			13.6		

### Storage of Ducting Products

All straight duct lengths are supplied either wrapped or within boxes, surrounded with white protective packaging to help mitigate damaging effects of sunlight exposure. Do not remove the white reflective packaging and leave in sunlight. UV exposure breaks down the polymer chains, resulting in a weaker molecular bond within the PVC, leading to reduced tensile strength and flexibility.

On receipt of goods, we recommend all PVC ducting products are immediately stored in a cool, shaded place to avoid damage due to heat build-up within the packaging. Any extrusions (lengths of product) should be stored horizontally and supported along the whole length of the product. In summer months, heat can build up inside packaging faster and there is a chance that PVC goods could become warped if stored incorrectly.

Vent-Axia will not be liable for any damage caused to ducting or PVC products through incorrect storage.

## Flat Channel Connector. F to F

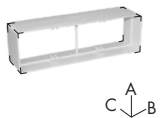

Stock Ref	Duct Size	External Dimensions (mm)			Resistance (Pa) at flow rate								
		A	B	C	8 l/s	13 l/s	21 l/s	29 l/s	37 l/s	45 l/s	53 l/s	61 l/s	
<b>436623<sup>(b)</sup></b>	204 x 60	64	212	100	<1	<1	<1	<1	<1	<1	1.2	1.5	
<b>436605</b>	110 x 54	54	114	100	<1	<1	1.1	1.4	2.2	3.4	4.8	6.4	
Stock Ref	Duct Size	A	B	C	60 l/s			120 l/s			180 l/s		
<b>403026</b>	220 x 90	95	224	52	<1			<1			<1		

## Channel Fixing Clip (Pack of 10)

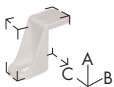

Stock Ref	Duct Size	External Dimensions (mm)			Resistance (Pa) at flow rate								
		A	B	C	60 l/s	120 l/s	180 l/s						
<b>403030</b>	220 x 90	97	44	19	N/A	N/A	N/A						

## Horizontal 90° Bend. F to F



Stock Ref	Duct Size	External Dimensions (mm)			Resistance (Pa) at flow rate								
		A	B	C	8 l/s	13 l/s	21 l/s	29 l/s	37 l/s	45 l/s	53 l/s	61 l/s	
<b>406879<sup>(a)</sup></b>	Insulated 204 x 60	210	385	385	0.7	1.7	4.1	8.4	13	18	25	34	
<b>436620<sup>(b)</sup></b>	Uninsulated 204 x 60	65	260	260	0.7	1.7	4.1	8.4	13	18	25	34	
<b>436602</b>	Uninsulated 110 x 54	60	152	152	2.3	9.9	21	38	64	93	124	162	
Stock Ref	Duct Size	A	B	C	60 l/s			120 l/s			180 l/s		
<b>407342<sup>(a)</sup></b>	Insulated 220 x 90	240	375	375	9			36			80		
<b>403028</b>	Uninsulated 220 x 90	95	250	250	9			36			80		

<sup>(a)</sup> Minimum insulation wall thickness 25mm. Insulation Thermal Conductivity: 0.04 W/(m.K)

<sup>(b)</sup> This part comes in Grey. Whilst we will look to maintain the colour of Grey, by the nature of adopting a recycled plastic the colour and shade may vary at any given time.

## Horizontal 45° Bend. F to F

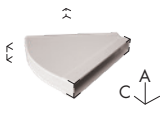

Stock Ref	Duct Size	External Dimensions (mm)			Resistance (Pa) at flow rate								
		A	B	C	8 l/s	13 l/s	21 l/s	29 l/s	37 l/s	45 l/s	53 l/s	61 l/s	
<b>437280</b>	Uninsulated 110 x 54	-	-	-	-	-	-	-	-	-	-	-	-
<b>406876</b> <sup>(a)</sup>	Insulated 204 x 60	210	390	385	0.2	0.7	1.2	2.1	3.8	6.1	9.2	13	
<b>249944A</b> <sup>(b)</sup>	Uninsulated 204 x 60	65	240	260	0.2	0.7	1.2	2.1	3.8	6.1	9.2	13	
Stock Ref	Duct Size	A	B	C	60 l/s			120 l/s			180 l/s		
<b>449363</b>	Uninsulated 220 x 90	95	240	200	5			20			46		

## Horizontal T. F to F to F

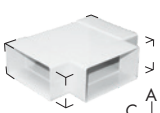

Stock Ref	Duct Size	External Dimensions (mm)			Resistance (Pa) at flow rate								
		A	B	C	8 l/s	13 l/s	21 l/s	29 l/s	37 l/s	45 l/s	53 l/s	61 l/s	
<b>406883</b> <sup>(a)</sup>	Insulated 204 x 60	210	410	380									
<b>436551</b> <sup>(b)</sup>	Uninsulated 204 x 60	65	310	255									
<b>436614</b>	Uninsulated 110 x 54	60	185	150									
Stock Ref	Duct Size	A	B	C	60 l/s			120 l/s			180 l/s		
<b>449365</b>	Uninsulated 220 x 90	95	275	250				Vary on installation			Vary on installation		

## Vertical 90° Bend. F to F

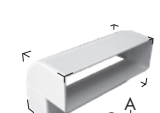

Stock Ref	Duct Size	External Dimensions (mm)			Resistance (Pa) at flow rate								
		A	B	C	8 l/s	13 l/s	21 l/s	29 l/s	37 l/s	45 l/s	53 l/s	61 l/s	
<b>406872</b> <sup>(a)</sup>	Insulated 204 x 60	240	360	240	1.1	2.5	5.2	9.8	16.1	24	33.6	45	
<b>436621</b> <sup>(b)</sup>	Uninsulated 204 x 60	115	210	115	1.1	2.5	5.2	9.8	16.1	24	33.6	45	
<b>436603</b>	Uninsulated 110 x 54	95	115	95	3.3	15.5	36	61	96	138	190	253	
Stock Ref	Duct Size	A	B	C	60 l/s			120 l/s			180 l/s		
<b>403029</b>	Uninsulated 220 x 90	117	224	120	7			28			66		

## Vertical 45° Bend. F to F

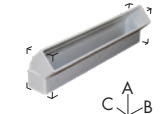

Stock Ref	Duct Size	External Dimensions (mm)			Resistance (Pa) at flow rate								
		A	B	C	8 l/s	13 l/s	21 l/s	29 l/s	37 l/s	45 l/s	53 l/s	61 l/s	
<b>406871</b> <sup>(a)</sup>	Insulated 204 x 60	225	360	230	0.1	0.5	1.3	2.5	4.4	6.9	10	13.3	
<b>445196</b> <sup>(b)</sup>	Uninsulated 204 x 60	100	210	115	0.1	0.5	1.3	2.5	4.4	6.9	10	13.3	
<b>441655</b>	Uninsulated 110 x 54	115	115	70	1	2.4	6.6	12.9	23.1	35.1	48	64	
Stock Ref	Duct Size	A	B	C	60 l/s			120 l/s			180 l/s		
<b>449364</b>	Uninsulated 220 x 90	110	225	115	6			27			65		

## Elbow Bend. 100mm to Rectangular. M to F

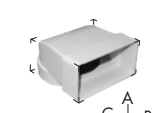

Stock Ref	Duct Size	External Dimensions (mm)			Resistance (Pa) at flow rate								
		A	B	C	8 l/s	13 l/s	21 l/s	29 l/s	37 l/s	45 l/s	53 l/s	61 l/s	
<b>436624</b> <sup>(b)</sup>	204 x 60	80	215	195	2.9	7.1	15.1	28	45.1	68.1	92.2	118	
<b>436607</b>	110 x 54	90	115	140	3	8	17.7	33	49.9	74.5	101	137	
Stock Ref	Duct Size	A	B	C	60 l/s			120 l/s			180 l/s		
<b>403027</b>	220 x 90	118	226	240	N/A			N/A			N/A		

## Elbow Bend. 125mm to Rectangular. M to F

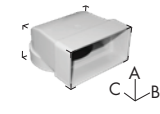

Stock Ref	Duct Size	External Dimensions (mm)			Resistance (Pa) at flow rate								
		A	B	C	8 l/s	13 l/s	21 l/s	29 l/s	37 l/s	45 l/s	53 l/s	61 l/s	
<b>436625</b> <sup>(b)</sup>	204 x 60	80	215	195	3.1	5.9	12.2	25	43.6	62.2	86	111	
Stock Ref	Duct Size	A	B	C	60 l/s			120 l/s			180 l/s		
<b>449361</b>	220 x 90	118	226	240	N/A			N/A			N/A		

<sup>(a)</sup> Minimum insulation wall thickness 25mm. Insulation Thermal Conductivity: 0.04 W/(m.K)

<sup>(b)</sup> This part comes in Grey. Whilst we will look to maintain the colour of Grey, by the nature of adopting a recycled plastic the colour and shade may vary at any given time.

# Ducting & Accessories

## Elbow Bend. 150mm to Rectangular. M to F

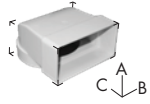

Stock Ref	Duct Size	External Dimensions (mm)			Resistance (Pa) at flow rate								
		A	B	C	8 l/s	13 l/s	21 l/s	29 l/s	37 l/s	45 l/s	53 l/s	61 l/s	
<b>436626**</b>	204 x 60	80	215	195	2.8	4.9	11.6	21	31	41	53	67	
<b>449362</b>	220 x 90	118	226	240	N/A			120 l/s			180 l/s		
					N/A			N/A			N/A		

## Elbow Bend. 100mm to Rectangular. F to F



Stock Ref	Duct Size	External Dimensions (mm)			Resistance (Pa) at flow rate								
		A	B	C	8 l/s	13 l/s	21 l/s	29 l/s	37 l/s	45 l/s	53 l/s	61 l/s	
<b>436608**</b>	110 x 54	90	115	140	2.1	5.5	14.3	27.2	44.3	69	93	118	

## Flat Channel connector with Damper



Stock Ref	Duct Size	External Dimensions (mm)			Resistance (Pa) at flow rate								
		A	B	C	8 l/s	13 l/s	21 l/s	29 l/s	37 l/s	45 l/s	53 l/s	61 l/s	
<b>400735</b>	110 x 54	60	115	75	16	17.5	19.5	22	25.5	30.5	36	42	

## Drop down section F to F



Stock Ref	Duct Size	External Dimensions (mm)			Resistance (Pa) at flow rate								
		A	B	C	8 l/s	13 l/s	21 l/s	29 l/s	37 l/s	45 l/s	53 l/s	61 l/s	
<b>442273</b>	204 x 60	120	220	210	0.2	0.5	1.7	3.6	6.0	9.1	12.4	16.6	

## Single Air Brick Horizontal (System 60 Air Grille Adaptor is supplied with the Single Air Bricks)

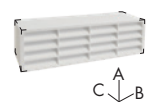

Stock Ref	Duct Size	External Dimensions (mm)			Resistance (Pa) at flow rate								
		A	B	C	8 l/s	13 l/s	21 l/s	29 l/s	37 l/s	45 l/s	53 l/s	61 l/s	
<b>436612</b>	110 x 54 (Terracotta)	65	210	85	3.2	7.8	20.9	39	65	96	128	176	
<b>436611</b>	110 x 54 (Brown)	65	210	85	3.2	7.8	20.9	39	65	96	128	176	

## Single Air Grille Soldier

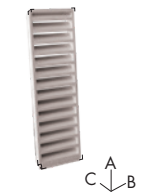

Stock Ref	Duct Size	External Dimensions (mm)			Resistance (Pa) at flow rate								
		A	B	C	8 l/s	13 l/s	21 l/s	29 l/s	37 l/s	45 l/s	53 l/s	61 l/s	
<b>438594</b>	204 x 60 (White)	210	65	15	3.3	10	20.6	40	63	92.8	128	168	
<b>468728A</b>	204 x 60 (Terracotta)	210	65	15	3.3	10	20.6	40	63	92.8	128	168	
<b>468730A</b>	204 x 60 (Brown)	210	65	15	3.3	10	20.6	40	63	92.8	128	168	
<b>468729A</b>	204 x 60 (Beige)	210	65	15	3.3	10	20.6	40	63	92.8	128	168	

\*\*This part comes in Grey. Whilst we will look to maintain the colour of Grey, by the nature of adopting a recycled plastic the colour and shade may vary at any given time.

## Double Air Brick

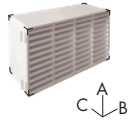

Stock Ref	Duct Size*	Colour	External Dimensions (mm)			Resistance (Pa) at flow rate							
			A	B	C	8 l/s	13 l/s	21 l/s	29 l/s	37 l/s	45 l/s	53 l/s	61 l/s
438604	204 x 60 or 220 x 90	White	145	245	80	0.2	1.6	4.3	8.7	13.9	21.1	27.5	37.4
438607		Terracotta	145	245	80	0.2	1.6	4.3	8.7	13.9	21.1	27.5	37.4
438605		Brown	145	245	80	0.2	1.6	4.3	8.7	13.9	21.1	27.5	37.4
438606		Beige	145	245	80	0.2	1.6	4.3	8.7	13.9	21.1	27.5	37.4

\*In conjunction with Double Air Brick Adaptor below

## Double Air Brick Adaptor Rectangular Duct

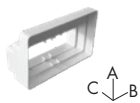

Stock Ref	Duct Size	External Dimensions (mm)			Resistance (Pa) at flow rate								
		A	B	C	8 l/s	13 l/s	21 l/s	29 l/s	37 l/s	45 l/s	53 l/s	61 l/s	
438608	204 x 60	135	226	85	-	-	-	-	-	-	-	-	-
449367	220 x 90	135	226	85	-	-	-	-	-	-	-	-	-

## Double Air Brick Adaptor Round Duct

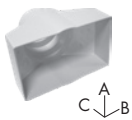

Stock Ref	Duct Size	External Dimensions (mm)			Resistance (Pa) at flow rate								
		A	B	C	8 l/s	13 l/s	21 l/s	29 l/s	37 l/s	45 l/s	53 l/s	61 l/s	
449360	220 x 90 to 100/125/150	-	-	-	-	-	-	-	-	-	-	-	-

## Air Grille Adaptor

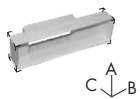

Stock Ref	Duct Size	External Dimensions (mm)			Resistance (Pa) at flow rate							
		A	B	C	8 l/s	13 l/s	21 l/s	29 l/s	37 l/s	45 l/s	53 l/s	61 l/s
436609	110 x 54	65	210	85	0.2	1.2	2.5	4.7	7.8	11	14	18

## Flexible Ducting



Stock Ref	Duct Size	External Dimensions (mm)			Resistance (Pa) at flow rate							
		A	B	C	8 l/s	13 l/s	21 l/s	29 l/s	37 l/s	45 l/s	53 l/s	61 l/s
5109662	204 x 60	-	-	-	0.2	0.6	1.5	2.6	4.1	6.0	8.2	11.5
449366	220 x 90	-	-	-	N/A		N/A		N/A		N/A	

## Round (M) 100mm to Rectangular (F/M) Adaptor

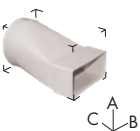

Stock Ref	Duct Size	External Dimensions (mm)			Resistance (Pa) at flow rate							
		A	B	C	8 l/s	13 l/s	21 l/s	29 l/s	37 l/s	45 l/s	53 l/s	61 l/s
441654 **	M to F 204 x 60	140	210	215	1.0	1.96	3.2	4.9	6.7	8.7	11.2	14.5
400740	M to M 110 x 54	100	115	180	1.2	4.2	8.3	19.8	29.9	42	60	86

\*\*This part comes in Grey. Whilst we will look to maintain the colour of Grey, by the nature of adopting a recycled plastic the colour and shade may vary at any given time.

# Ducting & Accessories

## Round (F) 125mm to Rectangular (F) Adaptor



Stock Ref	Duct Size	External Dimensions (mm)			Resistance (Pa) at flow rate							
		A	B	C	8 l/s	13 l/s	21 l/s	29 l/s	37 l/s	45 l/s	53 l/s	61 l/s
<b>370127**</b>	204 x 60	140	210	213	<1	<1	1.5	2.8	4.5	6.7	9	11.5

## Round (F) 150mm to Rectangular (F) Adaptor

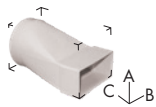

Stock Ref	Duct Size	External Dimensions (mm)			Resistance (Pa) at flow rate		
		A	B	C	60 l/s	120 l/s	180 l/s
<b>403031</b>	220 x 90	160	225	203	N/A	N/A	N/A

## Short Round (M) 100mm to 110 x 54 (F) Adaptor



Stock Ref	Duct Size	External Dimensions (mm)			Resistance (Pa) at flow rate							
		A	B	C	8 l/s	13 l/s	21 l/s	29 l/s	37 l/s	45 l/s	53 l/s	61 l/s
<b>455035</b>	110 x 54	60	110	105	1.2	4.3	8.4	20	30.2	43	62	88

## Round Ducting Insulated/Uninsulated

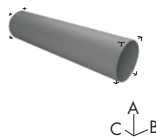

Stock Ref	Duct Size	External Dimensions (mm)			Resistance (Pa) at flow rate							
		A	B	C	8 l/s	13 l/s	21 l/s	29 l/s	37 l/s	45 l/s	53 l/s	61 l/s
<b>497488</b>	Uninsulated 100 Ø x 1m	100	100	1000	<0.5	<0.5	0.85	1.4	1.8	2.25	2.65	3.1
<b>406873</b>	Insulated 100 Ø* x 2m	250	250	2000	<1	<1	1.7	2.8	3.6	4.5	5.3	6.2
<b>5108250</b>	Uninsulated 100 Ø x 2m	100	100	2000	<1	<1	1.7	2.8	3.6	4.5	5.3	6.2
<b>496155</b>	Uninsulated 120 Ø x 1m	120	120	1000	<0.5	<0.5	<0.5	0.65	0.9	1.2	1.55	1.9
<b>434715</b>	Uninsulated 125 Ø* x 1.5m	125	125	1500	<1	<1	<1	1.3	1.8	2.4	3.1	3.8
<b>406874</b>	Insulated 125 Ø* x 2m	275	275	2000	<1	<1	<1	1.3	1.8	2.4	3.1	3.8
<b>496158</b>	Uninsulated 150 Ø x 1m	150	150	1000	<0.5	<0.5	<0.5	<0.5	0.6	0.8	1	1.25
<b>496159</b>	Uninsulated 150 Ø x 1.5m	150	150	1500	-	-	-	-	-	-	-	-
<b>406875</b>	Insulated 150 Ø* x 2m	315	315	2000	<1	<1	<1	<1	1.2	1.6	2	2.5
<b>5108248</b>	Uninsulated 150 Ø x 2m	150	150	2000	<1	<1	<1	<	1.2	1.6	2	2.5

### Storage of Ducting Products

All straight duct lengths are supplied either wrapped or within boxes, surrounded with white protective packaging to help mitigate damaging effects of sunlight exposure. Do not remove the white reflective packaging and leave in sunlight. UV exposure breaks down the polymer chains, resulting in a weaker molecular bond within the PVC, leading to reduced tensile strength and flexibility.

On receipt of goods, we recommend all PVC ducting products are immediately stored in a cool, shaded place to avoid damage due to heat build-up within the packaging. Any extrusions (lengths of product) should be stored horizontally and supported along the whole length of the product. In summer months, heat can build up inside packaging faster and there is a chance that PVC goods could become warped if stored incorrectly.

Vent-Axia will not be liable for any damage caused to ducting or PVC products through incorrect storage.

## Equal Tee Insulated/Uninsulated MMM



Stock Ref	Duct Size	External Dimensions (mm)			Resistance (Pa) at flow rate							
		A	B	C	8 l/s	13 l/s	21 l/s	29 l/s	37 l/s	45 l/s	53 l/s	61 l/s
<b>406884</b>	Insulated 100 Ø*	290	260	260	Vary on installation							
<b>372007</b>	Uninsulated 100 Ø	190	110	135	Vary on installation							
<b>406885</b>	Insulated 125 Ø*	310	265	285	Vary on installation							
<b>428636</b>	Uninsulated 125 Ø	210	115	160	Vary on installation							
<b>406886</b>	Insulated 150 Ø*	335	295	310	Vary on installation							
<b>370237</b>	Uninsulated 150 Ø	235	130	177	Vary on installation							

\*Minimum insulation wall thickness 25mm. Insulation Thermal Conductivity: 0.04 W/(m.K)

\*\*This part comes in Grey. Whilst we will look to maintain the colour of Grey, by the nature of adopting a recycled plastic the colour and shade may vary at any given time.

## 90° Bend Insulated/Uninsulated MM



Stock Ref	Duct Size	External Dimensions (mm)			Resistance (Pa) at flow rate								
		A	B	C	8 l/s	13 l/s	21 l/s	29 l/s	37 l/s	45 l/s	53 l/s	61 l/s	
<b>406880</b>	Insulated 100 Ø*	255	250	225	2.8	5.5	11	20.3	33	45	60	79	
<b>372004</b>	Uninsulated 100 Ø	130	100	100	2.8	5.5	11	20.3	33	45	60	79	
<b>406881</b>	Insulated 125 Ø*	285	280	255	<1	1.8	5	8.2	11.8	18	26	35	
<b>427360</b>	Uninsulated 125 Ø	160	130	130	<1	1.8	5	8.2	11.8	18	26	35	
<b>406882</b>	Insulated 150 Ø*	315	305	280	<1	1.0	2.5	4.1	6.4	9.6	13.5	18	
<b>370295</b>	Uninsulated 150 Ø	190	155	155	<1	1.0	2.5	4.1	6.4	9.6	13.5	18	

## 45° Bend Insulated/Uninsulated MM



Stock Ref	Duct Size	External Dimensions (mm)			Resistance (Pa) at flow rate								
		A	B	C	8 l/s	13 l/s	21 l/s	29 l/s	37 l/s	45 l/s	53 l/s	61 l/s	
<b>406877</b>	Insulated 100 Ø*	305	250	255	<1	1.9	8.1	11.7	17.5	24.6	31.4	-	
<b>372005</b>	Uninsulated 100 Ø	180	100	130	<1	1.9	8.1	11.7	17.5	24.6	31.4	-	
<b>406878</b>	Insulated 125 Ø*	325	280	275	<1	<1	1.8	2.9	4.6	6.6	9	12.2	
<b>441657</b>	Uninsulated 125 Ø	200	130	150	<1	<1	1.8	2.9	4.6	6.6	9	12.2	

## Connector MM



Stock Ref	Duct Size	External Dimensions (mm)			Resistance (Pa) at flow rate								
		A	B	C	8 l/s	13 l/s	21 l/s	29 l/s	37 l/s	45 l/s	53 l/s	61 l/s	
<b>372006</b>	100 Ø	100	60	-	-	-	-	-	-	-	-	-	
<b>428633</b>	125 Ø	125	60	-	-	-	-	-	-	-	-	-	
<b>370299</b>	150 Ø	150	60	-	-	-	-	-	-	-	-	-	

## Reducer



Stock Ref	Duct Size	External Dimensions (mm)			Resistance (Pa) at flow rate								
		A	B	C	8 l/s	13 l/s	21 l/s	29 l/s	37 l/s	45 l/s	53 l/s	61 l/s	
<b>VA54119</b>	125 to 100	130	57	-	-	-	-	-	-	-	-	-	
<b>428632</b>	150 to 125	155	57	-	-	-	-	-	-	-	-	-	

## Equal Y Piece

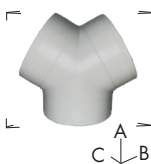

Stock Ref	Duct Size	External Dimensions (mm)			Resistance (Pa) at flow rate								
		A	B	C	8 l/s	13 l/s	21 l/s	29 l/s	37 l/s	45 l/s	53 l/s	61 l/s	
<b>497426</b>	100mm/4"	150	175	100	-	-	-	-	-	-	-	-	
<b>497428</b>	125mm/5"	173	199	125	-	-	-	-	-	-	-	-	
<b>497430</b>	150mm/6"	195	225	150	-	-	-	-	-	-	-	-	

\* Minimum insulation wall thickness 25mm. Insulation Thermal Conductivity: 0.04 W/(m.K)

\*\* This part comes in Grey. Whilst we will look to maintain the colour of Grey, by the nature of adopting a recycled plastic the colour and shade may vary at any given time.



# Ducting & Accessories



## Fabric Woven PVC Flexible Ducting

Manufactured using fabric woven PVC with a wire helix. Used with single spigots and in multi-duct systems. Operating temperature -30°C to 70°C.

### 6 metre lengths

Duct Size	Stock Ref
100 Ø	427569
125 Ø	427570
150 Ø	370281

## T-Series Flexible Ducting

PVC with wire helix. For use with T-Series.

### 6m lengths

Size	Duct Size	Stock Ref
Size 6	175 Ø	566607
Size 7	225 Ø	566609
Size 9	300 Ø	566612
Size 12	400 Ø	566616



## Insulated Flexible Ducting

Insulated ducting should be used when duct passes through an unheated area. Minimises heat loss when used with heat recovery fans. Available in 6 diameters. An additional benefit is that thermally insulated duct offers some measure of acoustic attenuation.

### 10 metre lengths

Duct Dia	Stock Ref
100 Ø	561654
125 Ø	561655
150 Ø	561656



## Duct Y Piece

For dividing a ventilation system, providing ducting to multiple supply or extract grilles using only a single fan source.

2x Into	1x	Stock Ref
100 Ø	100 Ø	452081
100 Ø	150 Ø	452082
125 Ø	125 Ø	455211
125 Ø	150 Ø	455212
150 Ø	150 Ø	452083
150 Ø	200 Ø	452084
200 Ø	200 Ø	452085
200 Ø	250 Ø	452078
250 Ø	250 Ø	452076
250 Ø	300 Ø	452079



## Acoustic Insulated Ducting

Multiple layer aluminium/polyester laminate with micro perforated flexible core to enhance acoustic performance. Core surrounded by 25mm fibreglass insulation with outer vapour barrier.

Duct Size	Length	Stock Ref
100 Ø	1m	443273
125 Ø	1.5m	443793
150 Ø	1m	443274



## Reducer

Duct Size	Stock Ref
R125/100	370302
R150/100	370303
R150/125	370304
R200/150	370307
R250/200	370309
R300/100	370310
R300/200	370312



### Circular Extract Diffuser

Manufactured from powder coated steel. Suitable for exhausting air and can be fitted directly to the duct or in the ceiling.

Duct Size	Stock Ref
125 Ø	10544125A
200 Ø	10544200A

---



### Circular Supply Diffuser

Manufactured from powder coated steel. Suitable for supplying air and can be fitted directly to the duct or in the ceiling.

Duct Size	Stock Ref
100 Ø	10543100A

---



### Acoustic Mat

486mm x 486mm x 25mm thick foam mat for use as a resilient mounting for wholehouse units.

Model	Stock Ref
ACM/House	370179

---



### Circular Push-Fit Supply Diffuser

Manufactured from ABS. Easy to install by direct push-fit into duct. Suitable for supplying air and can be fitted directly to the duct or in the ceiling.

Duct Size	Stock Ref
100 Ø	476936
125 Ø	476937
150 Ø	476938
200 Ø	476939

---



### Circular Push-Fit Extract Diffuser

Manufactured from ABS. Easy to install by direct push-fit into duct. Suitable for supplying air and can be fitted directly to the duct or in the ceiling.

Duct Size	Stock Ref
100 Ø	476944
125 Ø	476945
150 Ø	476946
200 Ø	476947

# Galvanised Spiral Wound Ducting

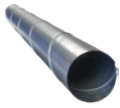

## Spiral Ductwork - 3m Length

Duct Size	Stock Ref
100 Ø	400900
125 Ø	400901
150 Ø	400902
200 Ø	410922
250 Ø	410923
315 Ø	410924

---



## Equal Tee

Duct Size	Stock Ref
100 Ø	400749
150 Ø	400751
315 Ø	410925

---



## 90° Bend

Duct Size	Stock Ref
125 Ø	400753
150 Ø	400754
200 Ø	370202

---



## Female Coupler

Duct Size	Stock Ref
100 Ø	400755
125 Ø	400756
150 Ø	400757
200 Ø	410927
315 Ø	410929

---



## Joining Piece

In sheet metal. For joining lengths of flexible ducting to give long lasting airtight connection.

Duct Size	Stock Ref
100 Ø	561804
125 Ø	561805
150 Ø	561806
200 Ø	561808
250 Ø	561810
315 Ø	561813

---



## Rectangular Balancing Damper

Duct Size	Stock Ref
110 x 54	405156
204 x 60	403698
220 x 90	403699

---



## Circular Balancing Damper

Duct Size	Stock Ref
100 Ø	400758
125 Ø	400759
150 Ø	400760
200 Ø	410930
250 Ø	410931
315 Ø	410932

---

# 100 - 150mm Accessories



## Wall Fitting Kit

A range of wall kits suitable for Vent-Axia range of 100 - 150mm fans. The kit can be installed into most walls using the telescopic liners supplied.

### White

Model	Stock Ref
100mm	254102
125mm	455226
150mm	140902A

### Brown

Model	Stock Ref
100mm	254100
125mm	497434
150mm	140903A

### Terracotta

Model	Stock Ref
125mm	497432



## Window Fitting Kit

For use in single or sealed double glazing and most materials up to 40mm thick.

### White

Model	Stock Ref
VA100 (105Ø)	254101A
VA100 (110Ø)	443234
Centra/Sil 100	442947
VA140/150	140901A
Solo Pro	11461685A



## Air Grille

Louvre grille for external termination of 100mm diameter rigid ducting. Consists of wall mounting piece and grille with 2 fixing screws.

Colour:	White or Brown
Dimensions:	155 x 155 x 32mm
Material:	ABS plastic

Colour	Stock Ref
White	563511
Brown	563500



## Termination Set

Used as a decorative inlet grille or soffit termination set in conjunction with 100mm or 125mm diameter ducting. Two fixing screws supplied to secure grille to the spigot through material up to 25mm thick. Dimension 155mm x 155mm.

Colour:	White
Material:	ABS plastic

Stock Ref	563513
-----------	--------

# 100 - 150mm Accessories



## Decoration Frame

A decoration frame that converts old Centrif to new Centrif Duo without the need to redecorate. The frame can be used with Quadra and Centrif Duo Plus.

The frame is simply installed using two wall fixing screws, allowing the fan to be mounted via its standard mountings. Finished in a high moulded material plastic colour matched to the fan.

Colour: White  
Size: 386mm x 296 x 32 mm deep

Stock Ref  
**442551**



## Quick Fit 100mm Airflow Shutter

Shutter with gravity flaps to protect against backdraught. The spigot connects to 100mm rigid ducting using quick fix grips provided.

Dimensions: 155 x 155 x 20mm  
Material: Plastic

Colour Stock Ref  
White **563522**  
Brown **563542**



## External Terminations Louvre Grille with Spigot

Plastic louvre grilles with either 100mm, 125mm or 150mm diameter spigots.

Duct Size	Colour	Stock Ref
100 Ø	Terracotta	<b>370328</b>
100 Ø	Brown	<b>370329</b>
100 Ø	White	<b>370330</b>
100 Ø	Grey	<b>495334</b>
100 Ø	Cotswold Stone	<b>495335</b>
100 Ø	Black	<b>495336</b>
125 Ø	Terracotta	<b>403569</b>
125 Ø	Brown	<b>436649</b>
125 Ø	White	<b>372278</b>
125 Ø	Grey	<b>403568</b>
125 Ø	Cotswold Stone	<b>403570</b>
125 Ø	Black	<b>495337</b>
150 Ø	Brown	<b>370337</b>
150 Ø	Terracotta	<b>370338</b>
150 Ø	White	<b>370339</b>
150 Ø	Grey	<b>495338</b>
150 Ø	Cotswold Stone	<b>495339</b>
150 Ø	Black	<b>495340</b>

# 100 - 150mm Accessories



## Quick Fit 100mm Grille

Terminates a rigid duct on an outside wall using the 'quick fix' side grips without the need for additional fixings.

<b>Colour</b>	<b>Stock Ref</b>
White	563521
Brown	563541



## Vent Cowl

External termination for 110mm diameter rigid ducting through roofs and walls in exposed situations. Overall diameter 200mm. Not suitable for use with flexible ducting.

<b>Material</b>	<b>Stock Ref</b>
Grey PVCu	561403



## Quick Fix Termination

The quick fix termination is designed to be installed from inside the building to a nominal 117mm or 165mm diameter core-cut hole, saving time and cost. Four sealing rings ensures a weather tight fit to the wall external leaf. Effective length 370mm.

<b>Duct Size</b>	<b>Stock Ref</b>
100 Ø	563535A
150 Ø	434656

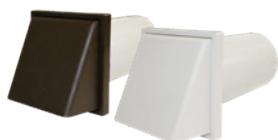

## Wind Baffle Kits

100mm wind baffle kit consisting of a telescopic wall tube and wind baffle. Available with either a white or brown wind baffle including foam lined damper to reduce noise.

<b>Colour</b>	<b>Stock Ref</b>
White	407382
Brown	407577



## Air Replacement Set

Bathroom and toilet ventilation is only effective when there is adequate air replacement into the room. This is often most effectively achieved by fitting a pair of air replacement grilles at low level in a door. Consists of a two piece telescopic set which fits unobtrusively on either side of the door panel.

<b>Minimum fixing thickness:</b>	30mm
<b>Dimensions:</b>	454 x 90mm
<b>Hole size:</b>	435 x 76mm
<b>Material:</b>	HIPS / High Impact Polystyrene
<b>Free area:</b>	16,600mm <sup>2</sup>

<b>Colour</b>	<b>Stock Ref</b>
Ivory	561401



## Condensation Trap

Condensation trap, for fitting in vertical rigid PVCu pipe ducting. Must be used where pipe ducts pass through unheated roof voids. Fitted with 20mm pipe connection for running off condensate. Not suitable for use with flexible ducting.

<b>Length:</b>	85mm
<b>Material:</b>	Grey PVCu

<b>Size</b>	<b>Stock Ref</b>
100mm	563516A
125mm	455191

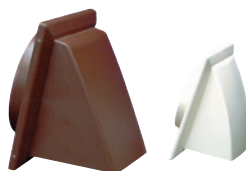

## Wind Baffles

A range of 150mm wind baffles. Cowlled wall outlet with damper protected gravity grille including foam lined damper to reduce noise.

Available in white and brown they are ideal for exposed coastal applications, helping to prevent unwanted backdraughts.

<b>150mm</b>	<b>Stock Ref</b>
<b>Colour</b>	
White	452096
Brown	452097

# Vent Duct Fire Sleeves

- Fire rated product up to EI 120 minutes
- Tested for masonry, concrete and plasterboard walls
- Tested in external wall / SFS constructions
- Can be installed within Ablative Coated Fire Batts
- CE Marked
- U/U - Uncapped/Uncapped tested as required for ventilated systems
- Can be retro fitted
- Low profile design
- Available preformed and ready to install in both circular or rectangular shapes
- Compressible material, offers accommodation for deflection
- No metal sleeving or boxing out required

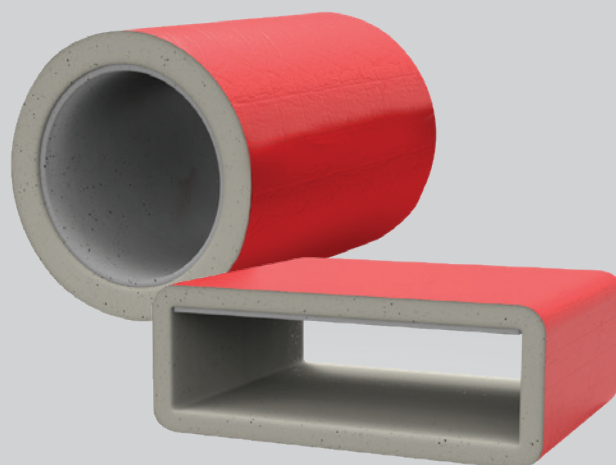

The FF109 Vent Duct Fire Sleeve Low Profiles (VDS LPs) are a family of CE Marked fire penetration seals designed to firestop PVC ventilation ducts/ pipes when installed through fire rated constructions.

The unique vacuum formed intumescent material design ensures that the expansion direction of the material crushes and seals the ducting in a fire situation without the need for any additional support or metal sleeving.

The lack of metal sleeving, not only makes installation easy, it also limits the risk of heat transfer through the structure as well as allowing compression to ensure a tight seal against fire and smoke or tight fitting against the ceiling soffit where needed.

The Fire Sleeves provide fire resistance ratings for Integrity (E) and Insulation (I) for up to EI120 minutes depending on the construction.

Fire Tested for both internal and external wall constructions. The Fire Sleeves are CE Marked with a European Technical Approval (ETA) based on extensive fire testing to BS EN 1366-3.

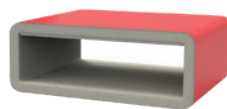

## Rectangular Fire sleeve - Low profile - 4 sided

Thickness:			10-15mm
CE Marked			
<b>Duct Size</b>	<b>Length</b>		<b>Stock Ref</b>
110x54mm	180mm		<b>407658</b>
204x60mm	180mm		<b>407659</b>
204x60mm	360mm		<b>474720</b>
220x90mm	180mm		<b>407660</b>

## Models

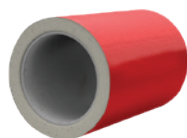

### Round Fire Sleeve - Low profile

Thickness:	10-15mm
Length:	280mm (180mm 407655)
CE Marked	
<b>Duct Size</b>	<b>Stock Ref</b>
100mm	<b>407655</b>
125mm	<b>407656</b>
150mm	<b>407657</b>



## Installation Variations

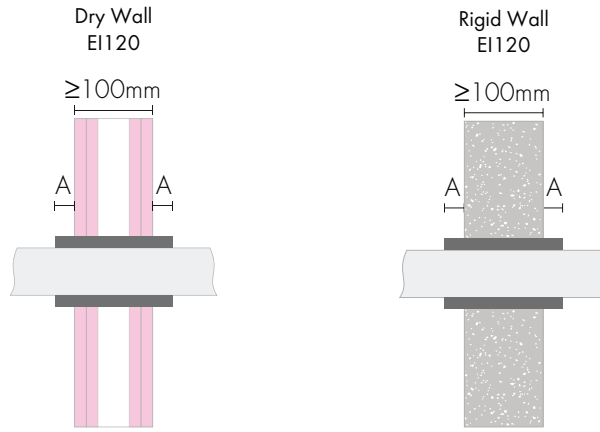

Test Standard	Duct Size Ref.	Duct Size (mm)	Duct Size Range (mm)	Wall		Min. Sleeve Length (mm)	Min. Protrusion (A) (mm)	Fire Rating	End Cap Conf.	Report No.
				Thickness (mm)	Material					
EN 1366-3	100	103	15-103	1.5	PVC	150	25	EI120	U/U	ETA 20-1164
EN 1366-3	125	127	15-127	1.8	PVC	250	75	EI120	U/U	ETA 20-1164
EN 1366-3	150	155	15-155	2.0	PVC	250	75	EI120	U/U	ETA 20-1164
EN 1366-3	110x54	110x54	110x54	1.5-1.8	PVC	150	25	EI120	U/U	ETA 20-1164
EN 1366-3	204x60	204x60	204x60	1.5-1.8	PVC	150	25	EI120	U/U	ETA 20-1164
EN 1366-3	220x90	220x90	220x90	1.5-1.8	PVC	150	25	EI120	U/U	ETA 20-1164

Service Support must be max. 300mm from the surface of the wall

Seals must be minimum 200mm apart

Rigid Walls must comprise concrete, aerated concrete or masonry with a minimum density of 650 kg/m<sup>3</sup> (wall type A, see ETA) or concrete or masonry with a minimum density of 1100 kg/m<sup>3</sup> (wall type B).

### Flexible Wall (external) EI90

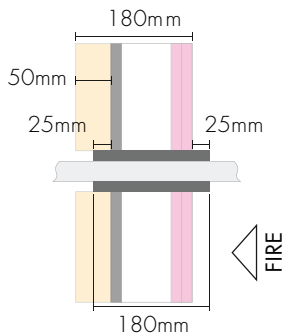

#### Construction Build-Up

Celotex PIR Foil Faced Insulation 50mm thick / 31kg/m<sup>3</sup>

Siniat GTEC Weather Defence Board SE 1x12.5mm

Rockwool ProRox SL920 Rock Fibre Insulation 100mm thick / 45kg/m<sup>3</sup>

Metsec Steel Stud 90mm wide

Siniat GTEC Fire Board SE Plasterboard 2x12.5mm

Test Standard	Duct Size Ref.	Duct Size (mm)	Duct Size Range (mm)	Wall Thickness (mm)	Material	Min. Sleeve Length (mm)	Min. Protrusion (mm)	Fire Rating	End Cap Conf.	Report No.
EN 1366-3	100	103	15-103	1.8	PVC	180	25	EI90	U/U	WF 411551
EN 1366-3	125	127	15-127	1.8	PVC	180	25	EI90	U/U	WF 411551
EN 1366-3	110x54	110x54	110x54	2.25 (+/- 0/15mm)	PVC	180	25	EI90	U/U	WF 411551
EN 1366-3	204x60	204x60	204x60	2.25 (+/- 0/15mm)	PVC	180	25	EI90	U/U	WF 411551
EN 1366-3	220x90	220x90	220x90	2.25 (+/- 0/15mm)	PVC	180	25	EI90	U/U	WF 411551

Service Support must be max. 300mm from the surface of the wall

Seals must be minimum 200mm apart

**Note:** Vent-Axia does not guarantee compliance with Building Regulations Part B, Fire Spread or other regulations that relate to fire planning. Suitability to comply with these regulations should be determined prior to installation and in conjunction with Building Control Officers. Compliance with the Regulations is specifically excluded from quotations and designs. For further information, please contact our technical support department.

## Installation Variations

**Fire Batt**  
100, 110x54, 204x60 & 220x90mm ducts only  
30/60 mins

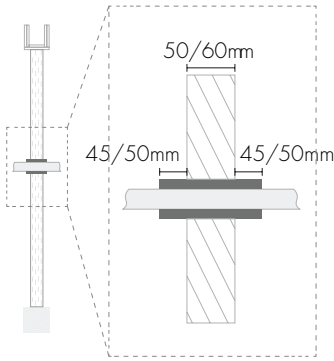

**Fire Batt**  
125 & 150mm ducts only  
30/60 mins

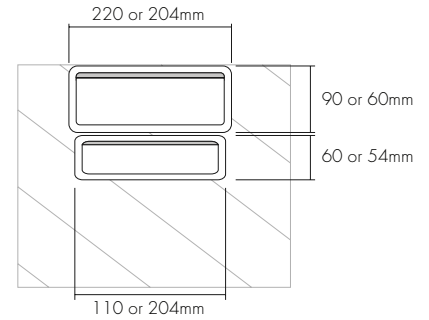
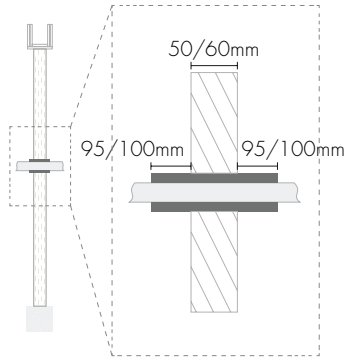

**Fire Batt**  
100, 110x54, 204x60 & 220x90mm ducts only  
90/120 mins

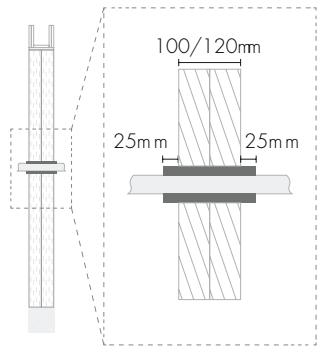

**Fire Batt**  
125 & 150mm ducts only  
90/120 mins

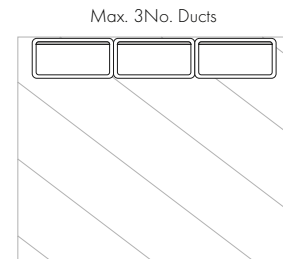
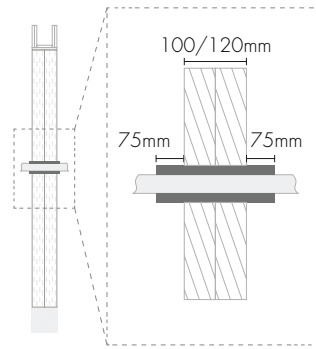

Test Standard	Duct Size Ref.	Duct Size (mm)	Wall Thickness (mm)	Material	Std. Sleeve Length (mm)	Min. Protrusion (mm)	Soffit Fix Allowed	Side by Side Installation	Stacked Ducts Allowed	Fire Rating	End Cap Configuration	Report No.
BS 476 Pt. 22	100	103	1.5	PVC	180	45/50mm or 25mm	N	N	N	30, 60, 90, 120	U/U	PAR/15162/01
BS 476 Pt. 22	125	127	1.8	PVC	280	95/100mm or 75mm	N	N	N	30, 60, 90, 120	U/U	PAR/15162/01
BS 476 Pt. 23	150	155	2.0	PVC	280	95/100mm or 75mm	N	N	N	30, 60, 90, 120	U/U	PAR/15162/01
BS 476 Pt. 22	110x54	110x54	1.5	PVC	180	45/50mm or 25mm	Y	Y	Y	30, 60, 90, 120	U/U	PAR/15162/01
BS 476 Pt. 22	204x60	204x60	1.5-1.8	PVC	180	45/50mm or 25mm	Y	Y	Y	30, 60, 90, 120	U/U	PAR/15162/01
BS 476 Pt. 22	220x90	220x90	1.8	PVC	180	45/50mm or 25mm	Y	Y	Y	30, 60, 90, 120	U/U	PAR/15162/01

Ablative Coated Batts, 50 or 60mm thick, must have suitable supporting documentation to demonstrate to the fire ratings required in accordance with BS476: Part 22

Min. spacing to seal edge or between penetrations must be 50mm

When rectangular ducts fixed underside the soffit, top edge of Fire Sleeve must be tight to the soffit, max. 5mm gaps allowable if sealed with intumescent acrylic sealant

When rectangular ducts fixed side by side, limited to maximum 3No., adjacent Fire Sleeves must be in close and constant contact

When rectangular ducts fixed side by side, ducts must be of the same size

When stacked ducts are installed, max. 2no. Stacked ducts of the same or similar size, e.g. 220x90 and 204x60 or 204x60 and 110x54.

Please refer to PAR/15162/01 for more limitations on multiple duct installations

Service Supports must be max. 300mm from the surface of the wall

Individual seal openings must be minimum 200mm apart

## Installation Variations

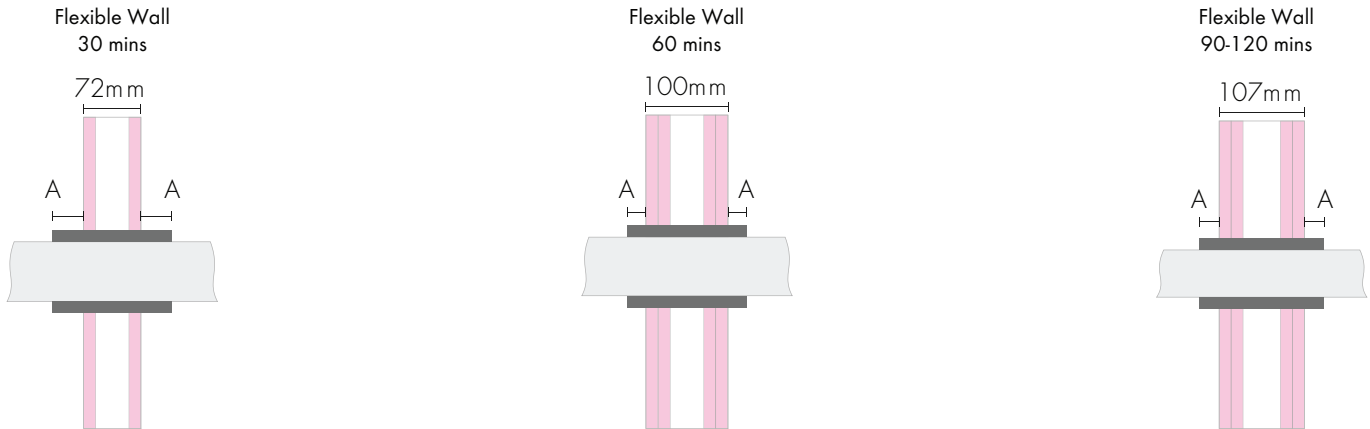

Test Standard	Duct Size Ref.	Duct Size (mm)	Wall Thickness (mm)	Material	Std. Sleeve Length (mm)	Min. Protrusion		Soffit Fix Allowed	Side by Side Installation	Fire Rating	End Cap Config.	Report No.
						in 72-99mm thick walls (mm)	in ≥100mm thick walls (mm)					
BS 476 Pt. 22	100	103	1.5	PVC	180	39	25	N	N	30, 60, 90, 120	U/U	PAR/14600/01
BS 476 Pt. 22	125	127	1.8	PVC	280	89	75	N	N	30, 60, 90, 120	U/U	PAR/14600/01
BS 476 Pt. 22	150	155	2.0	PVC	280	89	75	N	N	30, 60, 90, 120	U/U	PAR/14600/01
BS 476 Pt. 22	110x54	110x54	1.5	PVC	180	39	25	Y	Y	30, 60, 90, 120	U/U	PAR/14600/01
BS 476 Pt. 22	204x60	204x60	1.5-1.8	PVC	180	39	25	Y	Y	30, 60, 90, 120	U/U	PAR/14600/01
BS 476 Pt. 22	220x90	220x90	1.8	PVC	180	39	25	Y	Y	30, 60, 90, 120	U/U	PAR/14600/01

When rectangular ducts fixed underside the soffit, top edge of Fire Sleeve must be tight to the soffit, max. 5mm gaps allowable if sealed with intumescent acrylic sealant

When rectangular ducts fixed side by side, limited to maximum 3No., adjacent Fire Sleeves must be in close and constant contact

When rectangular ducts fixed side by side, ducts must be of the same size

Please refer to PAR/14600/01 for more limitations on multiple duct installations

Service Supports must be max. 300mm from the surface of the wall

Individual seal openings must be minimum 200mm apart

## Dimensions

Duct Size	Nominal Thickness	Nominal External Width /		Length
		Diameter	Nominal External Height	
110x54mm	10-15mm	134mm	83mm	180mm
204x60mm	10-15mm	228mm	89mm	180mm
204x60mm	10-15mm	228mm	89mm	360mm
220x90mm	10-15mm	244mm	124mm	180mm
220x90mm	10-15mm	244mm	124mm	360mm
100mm (103mm)	15mm	244mm	-	180mm
125mm (127mm)	15mm	160mm	-	280mm
150mm (155mm)	20mm	200mm	-	280mm

## Physical Properties

### Properties

Colour  
 Finish  
 Cuttability  
 Compressibility  
 Working Life  
 Storage  
 Transportation storage temperature  
 Durability  
 Smoke/Halogen Content

### Detail

Red  
 Glossy label on reinforced aluminium foil  
 Can be cut lengthways to retrofit  
 Does compress  
 48 years  
 Dry, ambient  
 -20°C to +70°C  
 Type X intended for use in conditions exposed to weather (UV, rain, frost)  
 Low Smoke / Zero Halogen

## Maintenance

No active maintenance required, where alterations are made around the product it should be checked visually to ensure that the product is still installed as per fitting instructions and tested systems.

## Fitting Instructions

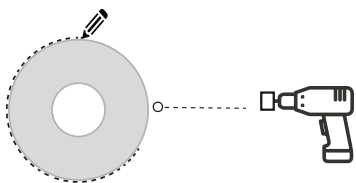

### Step 1a

If using a hole cutter for circular holes, ensure that the correct fire sleeve wall thickness (15mm + 15mm) 30mm total is added to the diameter of the pipe, this equals the aperture size. Cut the hole through the substrate using the correct blade, in the required location.

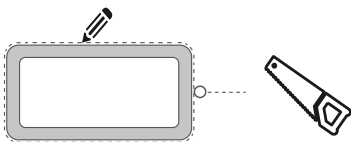

### Step 1b

If cutting without a hole cutter, using a pencil, draw around the fire sleeve at the required position of the aperture, ensure a tightly marked line. Use this line to cut the aperture through the substrate, using the required equipment as appropriate.

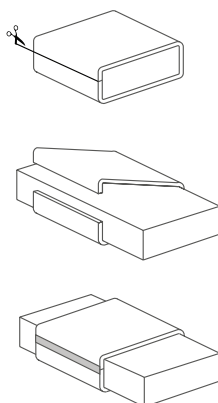

### Step 2

Unless the sleeve can be slid down the length of pipe/vent/duct to the aperture, carefully cut along the length of the fire sleeve, using a sharp knife or scissors, on a rectangular duct/vent cut centrally to one of the sides, place the sleeve around the pipe/duct/vent close to the aperture, and apply foil tape over the joint, where the sleeve was cut.

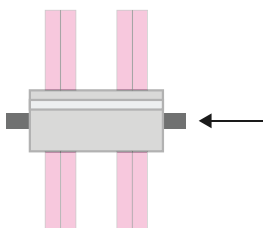

### Step 3

Push gently on the sleeve to pass it through the wall, if the sleeve covering starts to tear or if excessive resistance is felt, pull the sleeve back and trim the aperture. The sleeve should be pushed into the required position, ensuring that the required length of sleeve protrudes on either side of the wall.

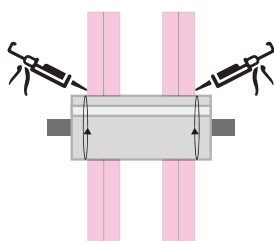

### Step 4 (If required)

If required for the purpose of smoke and draft stop, air or water tightness and airborne sound insulation, the gap between opening edge and fire sleeve may be sealed off by a suitable acrylic intumescent mastic construction sealant approved for penetration sealing applications.



# Fire Rated Air Valves

- Extract and Supply versions
- 60 Minutes Fire Rating in Solid Timber Joist Floor/Ceilings Constructions
- 30 Minutes Fire Rating in I-Beam and Metal Web Joist Floor/Ceiling Constructions
- No maintenance required
- Meets requirements of Approved Document B
- Simple to install



Fire Rated Air Valves are a unique and cost effective fire rated solution where recessed ceiling air valves are to be installed in fire rated floor/ceiling constructions. In a fire situation, the integral intumescent material rapidly expands to seal off the air valve to help maintain the fire resistance rating of the ceiling. This limits the risk of fire and heat spread throughout the building.

The Fire Rated Air Valves are available in all common sizes for both Extract and Supply. The Fire Rated Air Valves are installed as normal and require no addition maintenance over and above standard cleaning as would be carried out for any air valve. The product requires no maintenance after installation. The Fire Rated Air Valves are suitable for domestic homes, as well as apartments, hotels and other multiple occupancy buildings where fire ratings exist.

## Fitting Instructions

- Cut hole in ceiling to suit the outside diameter of the air valve mounting ring
- Fix the air valve to the ceiling via the screw holes in the valve
- Attach ducting onto the air valve mounting ring
- Fit the body of the valve into the mounting ring with a quarter turn twist
- Set inner cone clearance to provide required air flow rate (max. 12mm)
- Ensure the air valve is fitted snugly within the ceiling with no gaps or voids
- The penetration is then sealed against the spread of fire and the fire rating
- Other ceiling penetrations must be fitted a minimum of 200mm apart from the Fire Rated Air Valves

## Test Data

Report Type	Fire Test Lab	Report Number	Construction	Fire Rating
Full Scale Loaded Floor Fire Test to BS EN 1365-2	The Building Test Centre	BTC18074F / BTC 21144FA	Solid Timber Joist Floor	60 Minutes
Full Scale Loaded Floor Fire Test to BS EN 1365-2	Warrington Fire	422978	I-Beam Joist Floor	30 Minutes
Full Scale Loaded Floor Fire Test to BS EN 1365-2	Warrington Fire	394530	Metal Web Joist Floor	30 Minutes

## Storage & Durability

Storage	Dry, ambient
Transportation storage temperature	-20°C to +70°C
Working Life	48 years
Durability	Type X intended for use in conditions exposed to weather (UV, rain, frost)
Fungal Resistance	Protected by polythene
Smoke/Halogen Content	Low Smoke / Zero Halogen

## Models

Duct Size	Extract Stock Ref	Supply Stock Ref
100 Ø	403431	475661
125 Ø	403432	475662
150 Ø	403433	475663
200 Ø	408828	475664



**Note:** Vent-Axia does not guarantee compliance with Building Regulations Part B, Fire Spread or other regulations that relate to fire planning. Suitability to comply with these regulations should be determined prior to installation and in conjunction with Building Control Officers. Compliance with the Regulations is specifically excluded from quotations and designs. For further information, please contact our technical support department.

# Electric Heating



Vent-Axia heating is ideal for residential or commercial applications. So whether it's a bedroom or hallway, office or shop, we can provide the solution.

The simplicity of installing electric heating, particularly in high rise apartments means it is the natural choice for your project.

Comfort heating products with innovative zone control features provide energy savings for the occupier without compromising comfort in the home, coupled with low capital outlay they offer a cost effective solution for installer and occupier.

**Vent-Axia**







Heated Towel Rails

G3-G4

---



Radiant Heaters

G5-G6

---



Lot 20 Panel Heater

G7

---



Warm Air Curtains

G8

---



# Heated Towel Rails

- New and improved IP55 rated
- Plug kit can be handed left or right
- Five year leakage warranty
- One year manufacturer's warranty
- Heating element included
- Stylish designs
- Steel construction with high quality white and chrome finishes
- Production is carried out using latest technology resulting in absolute consistency in quality
- Complete fitting set supplied



## Range Options

Vent-Axia Heated Towel Rails quickly warm and dry towels. Their presence on the wall also adds to the overall style, temperature and comfort of the room.

This comprehensive range of white and chrome towel rails offers 9 different models across the flat, curved and designer ranges. The range offers sizes from 500 x 600mm to 500 x 1500mm available in four heat outputs of 100, 150, 250 and 400W matched to the size of the rail.

## Advantages of Towel Rails

Adequately heating your bathroom using a Vent-Axia towel rail not only leaves your towels warm and dry, but helps regulate temperature to the rest of the room decreasing the chances of mould and condensation.

## Product Selection

Sizing the correct towel rail can be made easy by using our online heating tool available on the website [www.vent-axia.com/heating-guide](http://www.vent-axia.com/heating-guide)

## Style and Comfort

With the Vent-Axia range of towel rails you will find a towel rail to suite all applications and sizes. Every towel rail uses thermally regulated heating elements and a mixture of high inertia fluid to order to maintain even heat distribution around the entire rail.

## Controller

The range is complemented by an advanced controller available in white and chrome giving you control of five heat outputs. The controller also offers an eco mode ideal for use when drying your towels to ensure minimal energy use. This feature turns on the rail on full power for 30 minutes then reduces the output to the user setting for a further 90 minutes before turning the towel rail off.



- IPX4 rated
- White or chrome finish
- Five power settings
- Eco timed function
- Two year warranty

Model	Stock Ref
VATRCW White	447864
VATRCC Chrome	447865

## Specification



Stock Ref	Model	Description	Finish	Dimensions mm		Output
				W	H	W
476254	VATR150F	Flat	Chrome	400	700	150
476255	VATR250F-W		White	500	1100	250
476256	VATR250F		Chrome	500	1100	250
476257	VATR400F		Chrome	500	1500	400



Stock Ref	Model	Description	Finish	Dimensions mm		Output
				W	H	W
476258	VATR250C	Curved	Chrome	500	1100	250
476259	VATR400C		Chrome	500	1500	400



Stock Ref	Model	Description	Finish	Dimensions mm		Output
				W	H	W
476260	VATR250-FR	Flat Railed	Chrome	500	1000	250
476261	VATR150-FR		Chrome	400	700	150



Stock Ref	Model	Description	Finish	Dimensions mm		Output
				W	H	W
476262	Varma	Designer	Chrome	500	1200	250



Stock Ref	Model	Description	Finish	Dimensions mm		Output
				W	H	W
476263	Atacama	Designer	Chrome	500	1200	250

# Radiant Heaters

- Economical and easy to install
- Silent in operation
- No yearly maintenance cost
- Instant heat from switch on
- Precision heating directed where needed

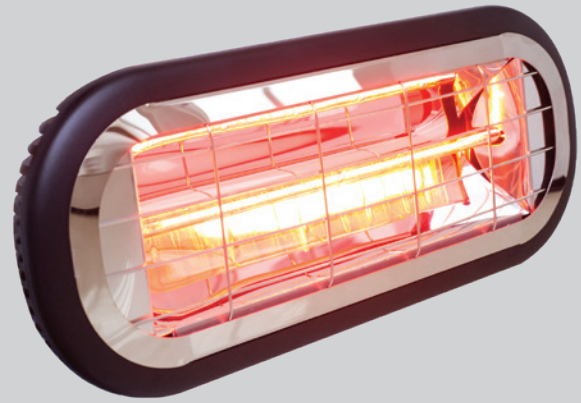

## Profile

The Vent-Axia radiant heating product range gives the flexibility to deal with large and small unheated spaces which would be uneconomical to heat using traditional space heating.

Areas such as bars, restaurants, terraces, delivery areas, warehouses and churches are some examples where the radiant heating products will provide an economical heating solution.

## Radiant heat and its advantages

The heat felt from the sun is called radiant heat and is part of the electromagnetic spectrum called infrared. Ultra violet and visible light also belong to the same family.

Visible light is the easiest part of this spectrum to understand, light travels in a straight line from the source, is unaffected by air and is invisible until it hits a surface. Shadows are a good example of this and are the absence of light.

Infrared rays behave in the same way, they cannot be seen but can be felt as warmth. A good example of this is the effect created when you move from the shade into the sun, although the temperature is the same, the perceived temperature when in direct sunlight is much higher. This phenomenon makes sunbathing possible during winter holidays. There are three categories of infrared; short wave (IR A), medium wave (IR B) and long wave (IR C), the shorter the wave length the easier it travels through the air.

The advantage when using short wave infrared heating is that the rays cut through the air and are not affected by air movement and only transmits its energy when it collides with a solid object. The rays also travel in a straight line so can be directed where you need it, ideal in locations which feature high ceilings, have high air change rates or are outside.

## Convection Heating and Radiant Heating Comparison

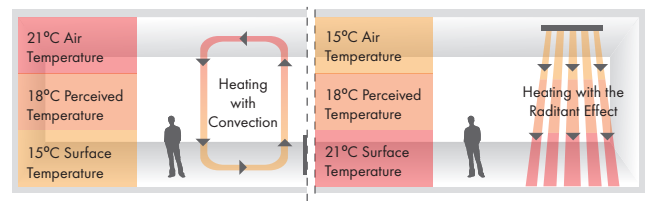

## Wave Infrared comparison

	Short Wave Infrared	Medium Wave Infrared	Long Wave Infrared
Typical source	IR Halogen Lamp	Quartz Heat Source	Resistance
Materials	Tungsten Filament welded in a quartz tube	Filament in compound of Fe-Cr-Al in a quartz tube	Filament in compound of Fe-Cr-Al in a steel tube
Radiant efficiency	92%	60%	40%
Switch on/off times	1 second	30 second	5 minutes

## Models



Model  
Sunburst 2kW

Stock Ref  
SUNB2000BL-VA

## Dimensions (mm)

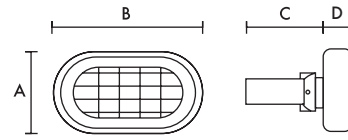

Stock Ref	A	B	C	D
SUNB2000BL-VA	190	460	113	107



Model  
Sunburst 3kW

Stock Ref  
SUNB3000BL-VA

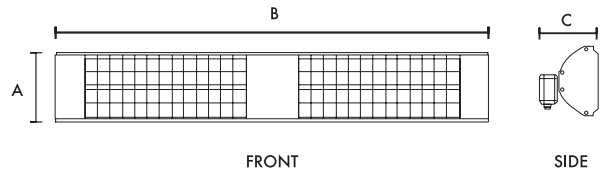

Stock Ref	A	B	C
SUNB3000BL-VA	150	935	85.5

## Technical Details

Stock Ref	Model	Weight kg	Voltage rating	Luminous spectrum	Accessories	Output W	Amps	Heating range m <sup>2</sup>	Lamp Type	Element Life Span
SUNB2000BL-VA	Sunburst 2kW	2.6	220-240V 50Hz	IR-A	Wall bracket	2000	9	10-12	Low glare halogen lamp	5000 hrs
SUNB3000BL-VA	Sunburst 3kW	4.6	220-240V 50Hz	IR-A	Wall bracket	3000	14	18-36	Long life carbon fibre lamp	10000 hrs

# Lot 20 Panel Heaters

- Complies with Lot 20 ERP directive
- Silent operation
- Energy saving 'open window' detection
- Slim line design with 3 sizes available
- Electronic thermostatic control accurate +/- 0.2°C
- Easy to use top mounted customised user-defined LCD display controls
- 7 day electronic programmable controls with backlit display
- 12 pre-set heating profiles
- Splash proof to IP24 for bathrooms or wet areas
- Overheat thermal cut-out
- Supplied with wall fittings
- Suitable for domestic or commercial application
- 2 year replacement warranty



## Comfort Heating

Lot 20 Panel Heaters are direct acting heaters, used to heat up a space quickly with 100% efficiency.

Vent-Axia's Panel Heaters offer a range of heat outputs from 1kW to 2kW and every model comes with electronic thermostatic control and 12 pre-set heating programmes. Vent-Axia Panel Heaters look as good as they perform. Stylish and slim, they occupy minimal wall space and are finished in an attractive gloss white finish.

Vent-Axia Panel Heaters are wall mounted and connected to the permanent electrical supply via a fused connection switched outlet. Vent-Axia Panel Heaters are supplied with mounting brackets, 1.5m of flex and come fitted with an easy to use LCD display screen.

## Models

Model	Stock Ref
VAPH1000	495792
VAPH1500	495793
VAPH2000	495794

## Adjustable Electronic Thermostat

All Vent-Axia Panel Heaters have a built-in adjustable thermostat offering a full temperature range between 5-30°C, including a 5°C frost protection setting.

For maximum safety there is also a child safety lock and thermal cut-out on all models to prevent overheating should the outlet grille be accidentally covered.



## Specification

Model	Power		Heating		Voltage	Approval	Product dimensions mm			Packaged dimensions mm			Product Weight kg	Gross Weight kg
	W	Colour	Setting W	Area m <sup>2</sup>			H	W	D	H	W	D		
VAPH1000	1000	White	1000	10-13	230-240V 50Hz	CE, EMC, LVD, RoHS, ERP	440	455	125	505	520	155	4	5.1
VAPH1500	1500		1500	15-18			440	615	125	505	680	155	5.1	6.3
VAPH2000	2000		2000	20-23			440	775	125	505	840	155	6.55	7.88

# Warm Air Curtains

- Integral switching for faster installation
- Three heat settings and fan only mode
- Models to suit single and double doorways
- Suitable for use as a high level fan heater

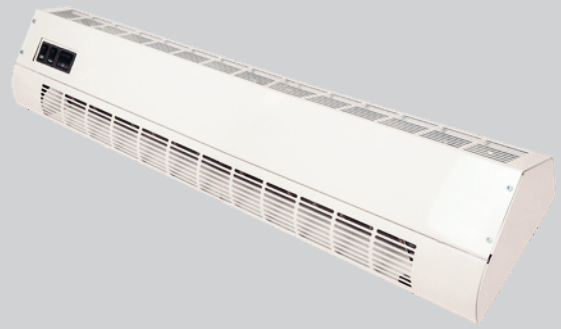

Vent-Axia Warmair Curtains provide a heated downflow of warm air in doorways of commercial premises such as shops, offices and schools.

The robust outer case is made from painted steel with an off white epoxy finish. Accommodating varying door widths is easily achieved by installing Warmair units 'side by side'.

Vent-Axia Warmair Curtains are supplied with 0.75m of 3 core cable, and mounting brackets. The mounting brackets are only available with Warmair 3 and Warmair 4.5, but not with the Warmair 6.

Three Warmair models are available offering heat outputs plus fan only setting:

- Warmair 3 - 3 kW, 2 kW, 1 kW
- Warmair 4.5 - 4.5 kW, 3 kW, 1.5 kW
- Warmair 6 - 6kW, 3 kW

## Models



### Warm Air Curtains

Model	Stock Ref
Warmair 3	456343
Warmair 4.5	456344
Warmair 6	456345

### Remote Switch

Remote Switch unit to control Warmair units. Switch allows for fan only & three heat settings.

Model	Stock Ref
VARSU	436494

## Specification

Model	Rating	Dimensions mm			Weight
	kW	W	H	D	kg
Warmair 3	3.0	650	103	210	6.1
Warmair 4.5	4.5	650	103	210	6.5
Warmair 6	6.0	900	103	210	8.7

220-240V-50Hz. BEAB Approved.



# Commercial Range



## Lo-Carbon T-Series

The UK's No. 1 Commercial Fan is available with a low energy DC motor providing up to 65% energy saving. The motor is designed to provide longer life, improved performance, lower running costs and maintain the T-Series rugged reliability. Vent-Axia have improved the way this product can be purchased for the refurbishment market. As well as being able to purchase it as you always have, you can also purchase it as a fan core plus optional application specific fitting kit, which gives you more flexibility in both stocking and installing the product. It also supports our lo-carbon drive to reduce waste and landfill.

**Vent-Axia**<sup>®</sup>



	ACM 100-200	H3-H4
	ACM 250-315	H5-H6
	Powerflow Range	H7-H8
	Lo-Carbon T-Series Overview	H9-H10
	Lo-Carbon T-Series Window Fan	H11-H12
	Lo-Carbon T-Series Wall Fan	H13-H14
	Lo-Carbon T-Series Roof Fan	H15-H16
	Lo-Carbon T-Series Panel Fan	H17-H18
	Traditional T-Series Overview	H19-H20
	Traditional T-Series Window Fan	H21-H22
	Traditional T-Series Wall Fan	H23-H24
	Traditional T-Series Roof Fan	H25-H26
	Traditional T-Series Panel/Ceiling Fan	H27-H28
	Traditional T-Series Darkroom Fan	H29-H30
	Traditional T-Series In-line Fan	H31-H32
	Super T-Series Heavy Duty Wall Fans	H33-H34

# ACM 100-200

- Designed and manufactured in the UK
- Three speed motor
- Timer versions available
- Removable motor core
- Rotating motor chassis
- IP44 rated
- Aesthetically pleasing with wipe clean polymer casing
- Sound data from independent testing
- Running speed selected on installation



## Ducted Ventilation

Vent-Axia has designed a complete range of energy efficient Mixed Flow In-Line fans that are now quieter, offer two and half times the pressure of conventional axial fans and are dimensionally more compact making them ideal for many ducted applications.

The ACM Mixed Flow In-Line fan can operate in both horizontal and vertical positions.

## Motor

All motors have three speeds selectable on installation and are fitted with Standard Thermal Overload Protection (S.T.O.P.). Designed for ambient temperatures up to +50°C. All sizes with capacitor run motors. All sizes are Class II appliances. Supply voltage 220-240V/1/50Hz.

## Installation

These units have a separate footplate for simple location mounting and detachable spigots for simple connection to ducting. The motor body chassis rotates to provide connection in acute spaces. Cleaning the product is simple as all parts can be removed without removing the ducting.

## Controller

For optimum variable speed performance use a Vent-Axia 1.5 Amp electronic controller. Surface mounted providing variable speed control with an On/Off/sensor slider with indication light. There is an adjustable minimum speed setting. The controller has electrical connections for use with suitable external sensors. Cannot be used with timer models.

1.5 Amp Controller (Suitable for 100mm - 200mm models). Dimensions: 86 x 156 x 53mm (H x W x D).

### Stock Ref

**W300310**

For flush fitting, a metal wall box accessory is available.

### Stock Ref

**400144**

Hole for wall box: 80 x 150 x 150mm (H x W x D).

## Models

Model	Stock Ref
ACM100	<b>17104010D</b>
ACM100T	<b>17104020F</b>
ACM125	<b>17105010D</b>
ACM125T	<b>17105020C</b>
ACM150	<b>17106010C</b>
ACM150T	<b>17106020D</b>
ACM200	<b>17108010B</b>
ACM200T	<b>17108020C</b>

## Dimensions (mm)

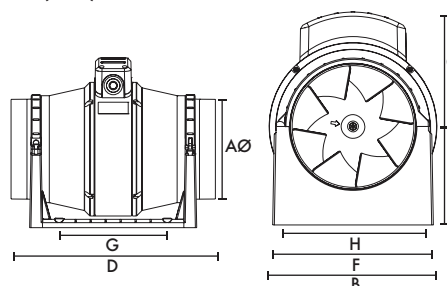

Size	100	125	150	200
AØ	97	122	147	199.5
B	178	178	200	223
C	124	124	138	146
D	298	259	350	300
E	96	96	118	130
F	168	168	192	195
G (fixing hole)	120	120	162	100
H (fixing hole)	153.5	153.5	178	180

## Performance Guide

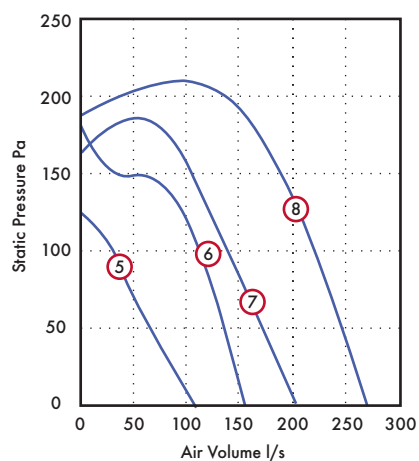
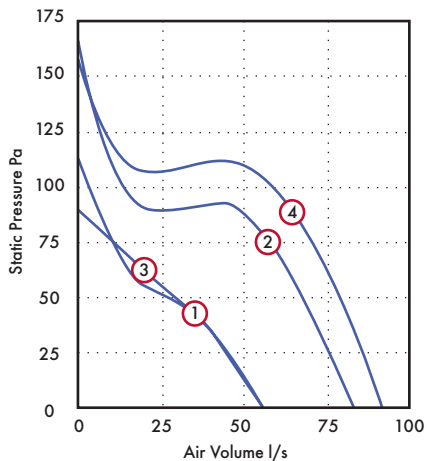

Dia.	Motor Phase	Speed	r.p.m	IP Rating	Curve Ref.	0	50	100	150	200	Motor kW	F.L.C Amps	dB(A) @ 3m
100	1	Low	1580	IP44	1	55	28	-	-	-	0.02	0.09	16
100	1	High	2200	IP44	2	85	69	33	-	-	0.02	0.1	22
125	1	Low	1450	IP44	3	55	30	-	-	-	0.02	0.1	17
125	1	High	2400	IP44	4	92	79	60	-	-	0.03	0.12	24
150	1	Low	1645	IP44	5	105	65	31	-	-	0.04	0.17	29
150	1	High	2350	IP44	6	155	135	112	46	-	0.05	0.21	36
200	1	Low	1845	IP44	7	204	170	138	103	-	0.08	0.48	26
200	1	High	2350	IP44	8	270	247	220	188	134	0.11	0.55	41

\*Medium speed is not shown.

## Sound Data

Dia.	Spectrum	63	125	250	500	1k	2k	4k	8k	dB(A) @ 3m
100	Breakout High	32	36	41	39	37	37	28	22	22
100	Breakout Low	30	31	34	36	28	29	23	22	16
100	Inlet High	38	42	57	56	54	46	38	30	37
100	Inlet Low	35	40	49	49	47	37	28	24	30
100	Outlet High	36	41	52	52	53	44	37	28	34
100	Outlet Low	38	41	45	46	45	36	28	24	27
125	Breakout High	32	33	38	41	41	40	33	23	24
125	Breakout Low	27	33	30	39	30	29	24	22	17
125	Inlet High	36	47	53	58	55	53	47	39	39
125	Inlet Low	38	42	45	48	45	41	35	26	29
125	Outlet High	36	47	51	54	55	50	46	37	37
125	Outlet Low	33	41	45	45	44	38	33	25	26
150	Breakout High	26	28	41	45	48	54	41	29	36
150	Breakout Low	21	29	45	49	43	44	32	22	29
150	Inlet High	40	49	59	63	59	63	55	47	46
150	Inlet Low	38	46	52	57	52	54	46	37	38
150	Outlet High	36	48	54	60	58	61	54	46	44
150	Outlet Low	33	45	49	54	54	52	45	36	37
200	Breakout High	38	53	47	47	56	60	44	33	41
200	Breakout Low	26	46	40	34	30	26	18	21	26
200	Inlet High	46	52	54	60	61	63	60	49	47
200	Inlet Low	38	37	40	41	39	35	24	23	22
200	Outlet High	63	68	69	73	70	69	62	54	54
200	Outlet Low	53	54	52	52	48	47	39	28	33

# ACM 250-315

- Available in two sizes
- Supplied complete for simple installation
- Optimise fan performance by using an approved Vent-Axia controller
- Diagonal impeller with stator
- Galvanized metal housing
- Integrated thermal switch
- Includes a mounting bracket
- Designed to meet IP54



## Ducted Ventilation

Vent-Axia has designed a complete range of energy efficient Mixed Flow In-Line fans for use with rigid and flexible ducting.

In-line Mixed Flow fans offer two and half times the pressure of conventional axial fans and are dimensionally more compact making them ideal for many ducted applications.

The ACM Mixed Flow In-Line fan can operate in both horizontal and vertical positions and can be mounted to meet its optimum performance.

## Motor

All motors are fitted with Standard Thermal Overload Protection (S.T.O.P.). Designed for ambient temperatures up to +50°C. All sizes with capacitor run motors. ACM 250 and 315 are Class I appliances. Supply voltage 220-240V/1/50Hz.

## Models

Model	Stock Ref
ACM250	17110010B
ACM315	17112010B

## ACM 250 Controller

For optimum performance use a Vent-Axia electronic controller. Surface mounted providing variable speed control with an On/Off/sensor slider with indication light. There is an adjustable minimum speed setting. The controller is radio suppressed to BS EN 55014 and electrical connections for use with suitable external sensors are provided.

1.5 Amp Controller – Suitable for 250mm model

Dimensions: 86 x 156 x 53mm (H x W x D).

Model	Stock Ref
1.5A Electronic Controller	W300310

## ACM315 Controller

The electronic infinitely variable fan speed controller allow you to manually adjust the speed of single phase AC fans by varying the motor voltage through phase angle control. The integrated switch enables or disables the motor.

Supply voltage:	230 VAC / 50–60 Hz
Regulated output:	U <sub>min</sub> –U <sub>s</sub>
Min. speed adjustment:	80–180 VAC
Unregulated output:	230VAC max 2.0A
Protection standard - Flush mounting:	IP44*
Protection standard - Surface mounting:	IP54*
Ambient conditions - Temperature:	0–40 °C
Ambient conditions - Rel. humidity:	5–95 % rH (non-condensing)
Maximum load - Rated max, current:	0.2 - 3.0A

\*According to EN 60529

Model	Stock Ref
3A Transformer Controller	SC5030

## Dimensions (mm)

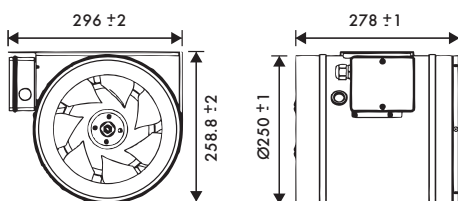

ACM250

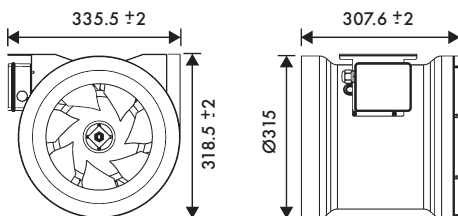

ACM315

## Performance Guide

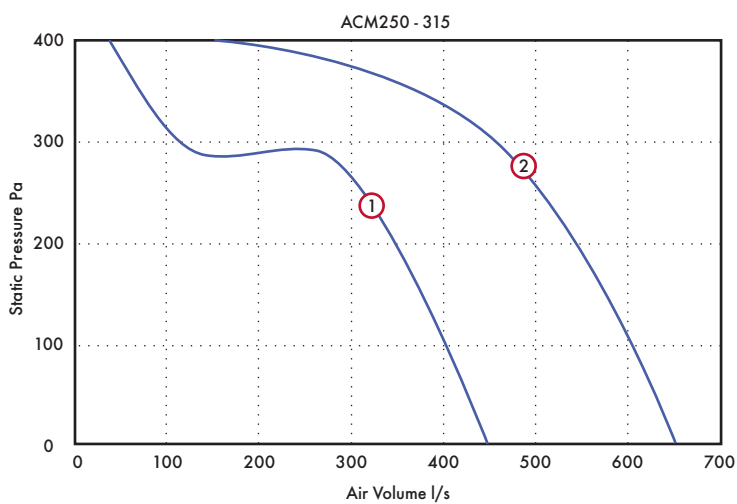

Dia.	Stock Ref.	Poles	r.p.m	IP Rating	Curve Ref.	l/s @ Pa					Motor kW	S.C. Amps	F.L.C Amps	dB(A) @ 3m
						0	100	200	300	400				
250	17110010	2	2720	IP54	1	450	410	350	120	40	0.14	0.8	1	53
315	17112010	2	2840	IP54	2	650	610	540	460	150	0.27	1.2	1.6	56

## Sound Data

Dia.	Spectrum	dB(A) @ 3m							
		125	250	500	1k	2k	4k	8k	
250	Inlet	34	54	61	65	67	66	55	72
250	Outlet	39	64	68	71	70	66	55	78
250	Breakout	34	41	43	46	46	42	37	54
315	Inlet	45	60	66	68	69	67	56	75
315	Outlet	47	69	73	74	72	66	57	79
315	Breakout	38	41	46	50	49	46	41	58

# Powerflow (ACP)

- Tough plastic in-line range in seven models
- 50-80mm long ribbed spigots
- Flame retardant casing
- All models speed controllable
- Fitted with Standard Thermal Overload Protection (S.T.O.P.)
- For the best performance from your fan, use a Vent-Axia controller
- IP44 Rated



## Ducted Ventilation

Powerflow models provide a compact yet versatile range designed with the installer in mind, combining the acoustic benefits of a tough plastic casing with the pressure characteristics of a centrifugal fan.

A range of seven models available from 100 to 315mm dia. duct sizes. The 315mm dia. model has been specifically developed for use with rigid ductwork. Air volumes from 59l/s to 340l/s in free air and capable of pressure development up to 500 Pa.

Powerflow has 50-80mm long inlet and discharge spigots allowing easy installation and fixing. The adjustable mounting foot allows the terminal box to be rotated to any angle and allows plenty of space and adjustment for screw fixing. The robust fire retardant polymeric casing combined with internal guide vanes ensures optimum airflow management through the unit.

## Electrical

Motors are 220-240V single phase 50Hz. Capacitor start and run. The terminal box is integral with the case moulding. All motors are fitted with Standard Thermal Overload Protection (S.T.O.P.).

## Motor/Impeller

All models are fitted with an external rotor motor and backward curved impeller assembly for long life and reliability.

All sizes are IP44 according to BS EN 60529. Ball bearings are greased for life and designed to run at any angle. Insulation is Class 'B' (from -30°C to +40°C). Manufacture is controlled to BS EN ISO 9001:2015.

## Models

2 Pole In-Line Duct Fan - Single Phase.

Stock Ref

ACP10012B

ACP12512B

ACP15012B

ACP16012B

ACP20012B

ACP25012B

ACP31512B

## 2.5A Electronic Controller

On/Off indication light. Infinitely variable speed control. Adjustable minimum speed setting and optional sensor mode. The controller is radio-suppressed to BS800 and rated at 2.5 amps.

Model

Stock Ref

2.5A Electronic Controller **W10303102M**

## Dimensions (mm)

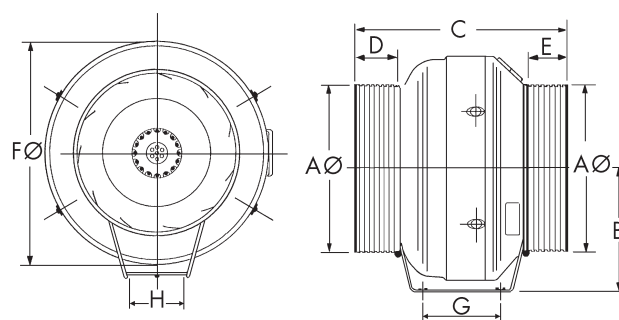

Dia	AØ	B	C	D	E	FØ	G	H	Weight
100	100	146	287	52	52	254	110	270*	2.2
125	125	146	287	60	60	254	110	270*	2.2
150	149	175	287	52	52	301	110	270*	3.1
160	160	175	287	52	52	301	110	270*	3.1
200	200	193	290	47	47	344	92	130	4.3
250	250	218	312	65	65	367	92	130	4.6
315	315	250	366	76	76	405	92	130	5.9

\*Sizes 100, 125, 150 & 160 have a flat mounting foot

# Performance Guide

100 to 315 dia. - 1 Phase - 2 Pole

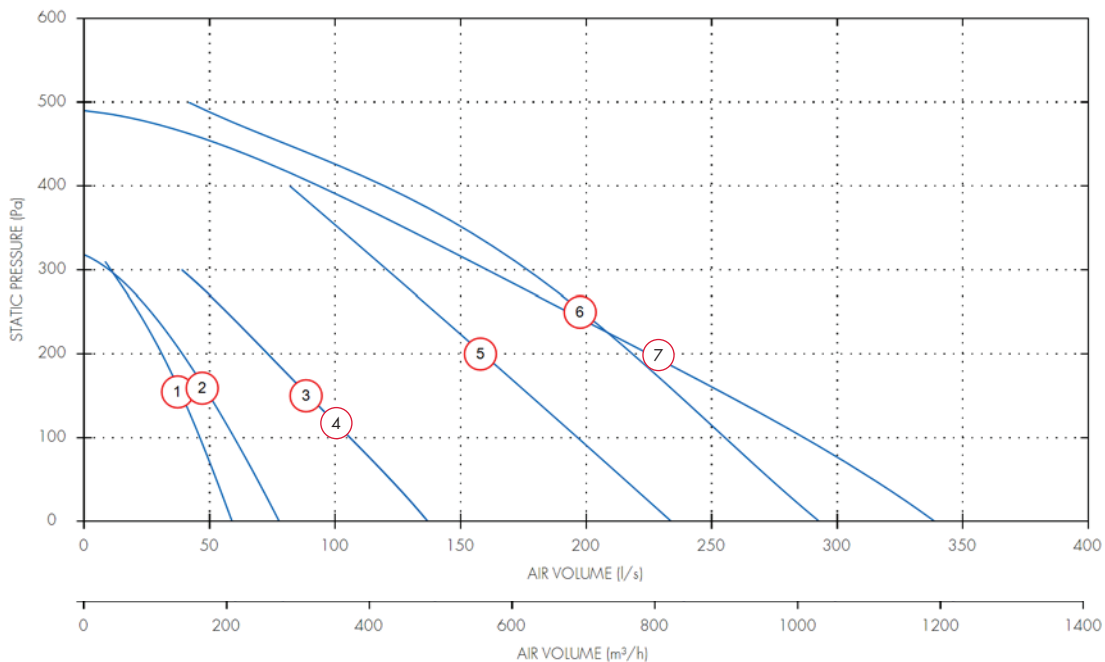

Dia.	Motor Phase	Stock Ref	r.p.m	IP Rating	Curve Ref.	l/s at Pa					Motor kW	S.C. Amps	F.L.C Amps	dB(A) @ 3m
						0	100	200	300	400				
100	1	ACP10012	2740	IP44	1	60	50	30	10		0.08	0.85	0.34	35
125	1	ACP12512	2410	IP44	2	80	60	40	10		0.08	0.85	0.34	35
150	1	ACP15012	2520	IP44	3	140	110	70	40		0.1	1.1	0.43	45
150	1	ACP16012	2520	IP44	4	140	110	70	40		0.1	1.1	0.43	45
200	1	ACP20012	2620	IP44	5	230	200	160	120		0.15	1.52	0.68	47
250	1	ACP25012	2720	IP44	6	290	260	220	180	120	0.19	1.6	0.77	48
315	1	ACP31512	2720	IP44	7	340	290	220	160	90	0.18	1.57	0.75	51

## Sound Data

Dia.	Motor Phase	Stock Ref.	Spectrum	dB(A) @ 3m								
				63	125	250	500	1k	2k	4k	8k	
100	1	ACP10012	Inlet	81	84	75	68	61	52	46	40	51
100	1	ACP10012	Outlet	82	84	77	68	61	52	49	43	52
100	1	ACP10012	Breakout	52	48	57	53	53	48	40	38	36
125	1	ACP12512	Inlet	80	79	76	70	61	57	51	45	51
125	1	ACP12512	Outlet	82	80	76	71	61	54	51	43	52
125	1	ACP12512	Breakout	52	48	57	53	53	48	40	38	36
150	1	ACP15012	Inlet	79	84	84	76	69	65	61	52	58
150	1	ACP15012	Outlet	78	84	83	74	69	65	60	50	57
150	1	ACP15012	Breakout	59	62	66	62	62	58	51	43	45
150	1	ACP16012	Inlet	81	81	79	76	66	61	58	49	55
150	1	ACP16012	Outlet	80	82	81	73	67	62	57	49	55
150	1	ACP16012	Breakout	59	62	66	62	62	58	51	43	45
200	1	ACP20012	Inlet	80	79	74	76	67	65	66	60	55
200	1	ACP20012	Outlet	79	79	74	71	69	69	65	59	55
200	1	ACP20012	Breakout	54	70	67	66	62	59	53	43	47
250	1	ACP25012	Inlet	84	80	74	74	69	69	67	63	56
250	1	ACP25012	Outlet	75	79	73	72	72	73	68	64	58
250	1	ACP25012	Breakout	60	71	70	66	65	62	55	44	49
315	1	ACP31512	Inlet	84	80	74	74	69	69	67	63	56
315	1	ACP31512	Outlet	75	79	73	72	72	73	68	64	58
315	1	ACP31512	Breakout	72	71	73	71	66	63	55	45	52



# Lo-Carbon T-Series Range Overview

- Wall, Window, Roof and panel mounting versions available
- Low Energy DC Motor
- Up to 70% energy saving
- Modular design, available as a complete unit or as a separate fitting kit and fan core for refurbishment



## ErP Regulations

The introduction of the ErP regulations gave us the opportunity to review our product ranges and has enabled us to improve the way we stock and sell them. You can still buy the market leading T-Series in the same way you always have, as a complete product, however we have taken the opportunity to add a more flexible option if you need it. We have introduced a modular option for refurbishment situations where you may not want to replace the whole product.

For new build projects and complete building refits the market leading T-Series is unchanged and available as a complete unit generally supplied in one carton.

For refurbishment markets, supplying it as separate core and specific fitting kit gives more flexibility in both stocking and installing the product. This also gives the lowest overall cost to refurbish your fan system without changing wiring or controls, furthermore it also supports our Lo-Carbon drive to reduce waste and landfill.

Wired controller available to make the Lo-Carbon T Series range the most flexible, efficient and controllable range of commercial wall and window fan systems.

## Complete Product Option

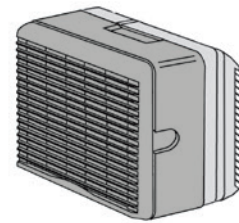

Complete product

## Modular Option

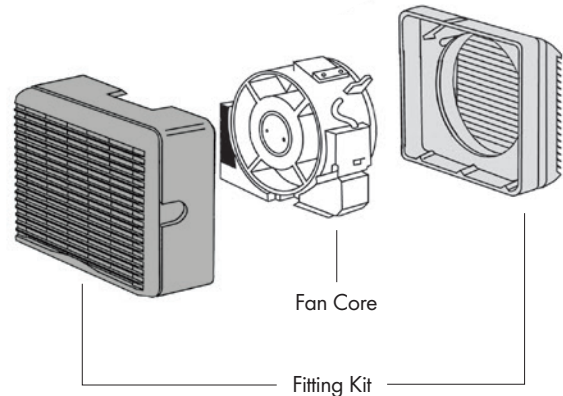

## Lo-Carbon T-Series Complete Fan



Controller Type*	Size	Window Stock Ref	Wall Stock Ref	Roof Stock Ref	Panel Stock Ref
Wired	9"	456165	456166	456168	456167
Wired	12"	456173	456174	456176	456175

\* Wired refers to the controller type that can be utilised with the particular model.

## Lo-Carbon T-Series Modular Option



Fitting Kit Options (excludes Fan Core)

Controller Type*	Size	Fan Core Stock Ref	Window Stock Ref	Wall Stock Ref	Roof Stock Ref	Panel Stock Ref
Wired	9"	472039	472047	472043	472055	472051
Wired	12"	472040	472048	472044	472056	472052

\* Wired refers to the controller type that can be utilised with the particular model.

# Lo-Carbon T-Series Window Fan

- Reduces your carbon footprint
- Extract/intake model in 2 sizes: 9" and 12"
- Long life Lo-Carbon motor lasts twice as long as conventional motors
- Up to 70% energy saving
- Easy fit connector Top Socket, standard on all models



## UK's No. 1 Commercial Fan

The Lo-Carbon T-Series Fan range utilises a low energy DC motor, developed to improve performance, lower running costs and maintain T-Series' rugged reliability.

## Window Fan

The fitting kit is designed for installation through single or double glazing and material up to 32mm thick. Greater thicknesses can be accommodated using extended fixing rod sets. Alternatively, the Lo-Carbon T-Series range can be used in conjunction with Vent-Axia ventilation accessories in flexible and rigid ducting systems to suit individual requirements. It can also be mounted in a fixing plate on walls or above ceilings.

## Instantaneous Shutter

With energy saving in mind, units are supplied complete with an integral instantaneous automatic louvre shutter concealed behind the interior grille. It operates on both extract and intake and at any angle of mounting.

The shutter is electronically controlled by an actuator with a damped action giving quiet operation during instant opening and closing. The interlocking edges of the shutter blades provide maximum back draught protection. When the fan is used with the Lo-Carbon T-Series controller, the shutter can be set open with the fan motor switched Off to provide natural ventilation without the security risk of an open window.

## Top Socket

A connector Top Socket is standard on all T-Series fans. Allowing fast and trouble-free mains connection.

## Models

### Complete Fan

Model	Stock Ref
9" Wired	456165
12" Wired	456173

### Fan Core (excludes Window Kit)

Model	Stock Ref
9" Wired	472039
12" Wired	472040

### Window Kit (excludes Fan Core)

Model	Stock Ref
9" Wired	472047
12" Wired	472048

## Accessory

### Extended Fixing Rod set

Size	Stock Ref
9"	568104
12"	568106

## Controller



Models	Stock Ref
Wired	455873

## Dimensions (mm)

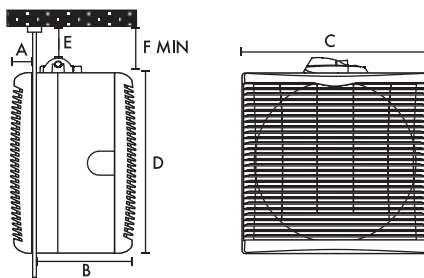

Size Dim.	9 in	12 in
A	39	41
B	150	177
C	304	381
D	302	378
E	19	19
F	54	54
Fixing hole Ø	260	337
Weight kg*	5.35	7.7

\*Complete product. Controller (W x H x D) 97 x 99 x 32

## Performance Guide

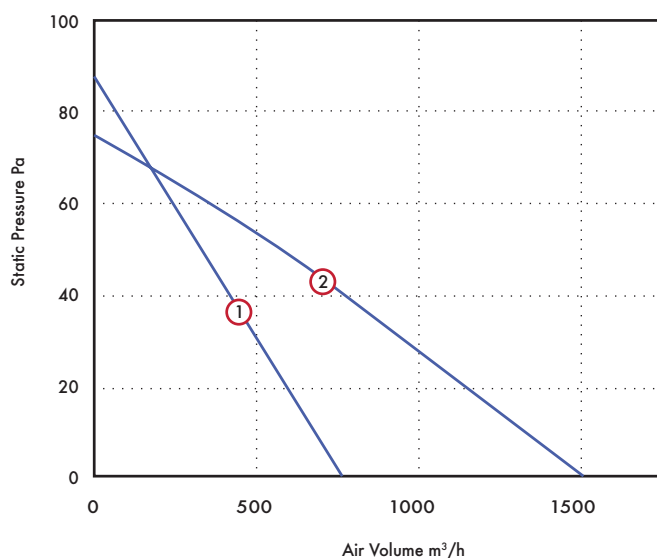

Model	Curve	Extract performance m³/h (l/s)			Watts (high)	Sound dB(A) (med) @ 3m	Amps @ 240V
		low	medium	high			
Lo-Carbon 9" Window - Wired	①	332 (90)	571 (160)	761 (210)	30.8	40	0.35
Lo-Carbon 12" Window - Wired	②	660 (185)	1295 (360)	1550 (430)	68.6	46	0.73

# Lo-Carbon T-Series Wall Fan

- Long life Lo-Carbon motor lasts twice as long as conventional motors
- Reduces your carbon footprint
- Extract/intake model in 2 sizes: 9" and 12"
- Up to 70% energy saving
- Easy fit connector Top Socket, standard on all models



## UK's No. 1 Commercial Fan

The Lo-Carbon T-Series Fan range utilises a low energy DC motor, developed to improve performance, lower running costs and maintain T-Series' rugged reliability.

## Wall Fan

Lo-Carbon T-Series wall models are designed to fit directly into double brick, solid and cavity walls. The two part telescopic liner accommodates wall thicknesses from 240 to 315mm. For thicker walls additional liner sections are available. Lo-Carbon T-Series wall models are provided with internal and external wall frames which fit flush with both faces of the wall.

## Instantaneous Shutter

Lo-Carbon T-Series models are supplied complete with an integral instantaneous automatic louvre shutter which will operate on both intake and extract and at any angle of mounting.

When the fan is used with a Lo-Carbon T-Series controller, the shutter can be set open with the fan motor switched Off to provide natural ventilation without the security risk of an open window.

## Electrical

Motor purpose-designed. Suitable for running at any angle. Quiet running. Suitable for operation in ambient temperatures from -40°C to +50°C.

Fitted with self resetting Standard Thermal Overload Protection (S.T.O.P.).

Supply voltage 220-240V/1/50Hz.

## Top Socket

A connector Top Socket is standard on all T-Series fans. Allowing fast and trouble-free mains connection.

## Models

### Complete Fan

Size	Stock Ref
9" Wired	456166
12" Wired	456174

### Fan Core (excludes Wall Kit)

Size	Stock Ref
9" Wired	472039
12" Wired	472040

### Wall Kit (excludes Fan Core)

Size	Stock Ref
9" Wired	472043
12" Wired	472044

## Accessory

### Additional Wall Liner Section

Size	Stock Ref
9"	460096
12"	460086

## Controller



Models	Stock Ref
Wired	455873

## Dimensions (mm)

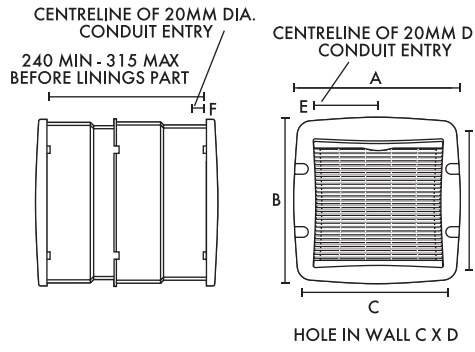

Size Dim.	9 in	12 in
A	391	470
B	388	467
C	365	442
D	375	450
E	143	182
F	25	25
Weight kg*	7.77	10.86

\*Complete product. Controller (W x H x D) 97 x 99 x 32

## Performance Guide

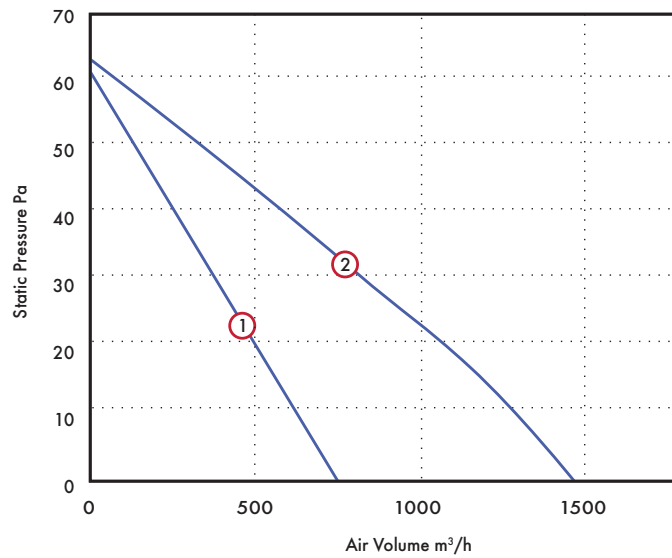

Model	Curve	Extract performance m³/h (l/s)			Watts (high)	Sound dB(A) (med) @ 3m	Amps @ 240V
		low	medium	high			
Lo-Carbon 9" Wall - Wired	①	326 (90)	562 (160)	732 (210)	27	39	0.31
Lo-Carbon 12" Wall - Wired	②	660 (185)	1355 (360)	1650 (430)	68	48	0.70

# Lo-Carbon T-Series Roof Fan

- Reduces your carbon footprint
- Extract / intake model in 2 sizes: 9" and 12"
- Long life Lo-Carbon motor lasts twice as long as other conventional motors
- Up to 70% energy saving
- Easy fit connector Top Socket, standard on all models



## UK's No. 1 Commercial Fan

The Lo-Carbon T-Series Fan range utilises a low energy DC motor, developed to improve performance, lower running costs and maintain T-Series' rugged reliability.

## Roof Fitting Kit

Designing ventilation systems with the unit mounted in a skylight or a flat roof is easy. With a low profile cowl, the Lo-Carbon T-Series Roof model is suitable for installation in horizontal, angled (max pitch 30deg) and vertical glass and for fixing plates in roofs. For vertical windows or walls in exposed areas and single and double glazing including most types of glass up to 32mm thick. Greater thicknesses can be accommodated using extended fixing rod sets. Both sizes of Vent-Axia roof plate assemblies can be fitted easily into flat roofs.

## Instantaneous Shutter

With energy saving in mind, Lo-Carbon T-Series models are supplied complete with an integral, instantaneous, automatic louvre shutter concealed behind the interior grille.

It will operate on both intake and extract and at any angle of mounting. The shutter is electronically controlled by an actuator with a damped action giving quiet operation during instant opening and closing.

When the fan is used with a Lo-Carbon T-Series controller, the shutter can be set open with the fan motor switched off to provide natural ventilation without the security risk of an open window.

## Top Socket

A connector Top Socket is standard on all T-Series fans. Allowing fast and trouble-free mains connection.

## Electrical

Motor purpose-designed. Suitable for running at any angle. Quiet

running, enclosed. Suitable for operation in ambient temperatures from -40°C to +50°C.

Fitted with self resetting Standard Thermal Overload Protection (S.T.O.P.).

Supply voltage 220-240V/1/50Hz.

## Models

### Complete Fan

Model	Stock Ref
9" Wired	456168
12" Wired	456176

### Fan Core (excludes Roof Kit)

Size	Stock Ref
9" Wired	472039
12" Wired	472040

### Roof Kit (excludes Fan Core)

Size	Stock Ref
9" Wired	472055
12" Wired	472056

## Controller



Models	Stock Ref
Wired	455873



Dimensions (mm)

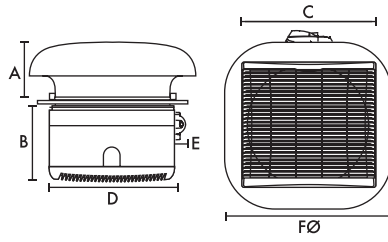

Size Dim.	9 in	12 in
A	136	171
B	150	177
C	304	381
D	302	378
E	54	54
FØ	400	500
Fixing Hole	260	337
Weight kg*	6.22	9.28

\*Complete product. Controller (W x H x D) 97 x 99 x 32

Performance Graph

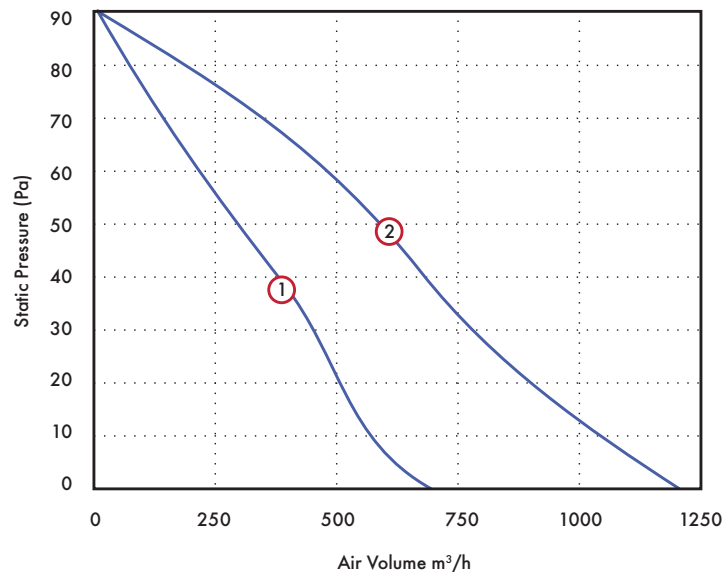

Model	Curve	Extract performance m³/h (l/s)			Watts (high)	Sound dB(A) (med) @ 3m	Amps @ 240V
		low	medium	high			
Lo-Carbon 9" Roof - Wired	1	313 (85)	562 (155)	693 (190)	27	40	0.34
Lo-Carbon 12" Roof - Wired	2	518 (143)	1017 (282)	1194 (330)	67	48	0.69

# Lo-Carbon T-Series Panel Fan

- Reduces your carbon footprint
- Extract / intake model in 2 sizes: 9" and 12"
- Long life Lo-Carbon motor last twice as long as other conventional motors
- Up to 70% energy saving
- Easy fit connector Top Socket, standard on all models



## UK's No. 1 Commercial Fan

The Lo-Carbon T-Series Fan range utilises a low energy DC motor, developed to improve performance, lower running costs and maintain T-Series' rugged reliability.

## Panel Fitting Kit

Lo-Carbon T-Series panel/ceiling models are suitable for mounting at any angle in internal partitions, ceilings, ducts and, with louvre grilles, through external walls. When installed only the louvre grille is visible.

## Instantaneous Shutter

With energy saving in mind, Lo-Carbon T-Series models are supplied complete with an integral instantaneous automatic louvre shutter concealed behind the interior grille. With a Lo-Carbon T-Series Controller the fan will operate on both extract and intake, suitable for any angle of mounting. When the fan is used with a Lo-Carbon T-Series controller, the shutter can be set open with the fan motor switched off to provide natural ventilation without the security risk of an open window.

## Top Socket

A connector Top Socket is standard on all T-Series fans. Allowing fast and trouble-free mains connection.

## Electrical

Suitable for operation in ambient temperatures from -40°C to +50°C.

Fitted with self resetting Standard Thermal Overload Protection (S.T.O.P).  
Supply voltage: 220-240V/1/50Hz.

## Easy Cleaning

Integrated component design allows all parts to be dismantled for cleaning without the use of specialist tools.

## Models

### Complete Fan

Size	Stock Ref
9" Wired	456167
12" Wired	456175

### Fan Core (excludes wired Panel Kit)

Size	Stock Ref
9" Wired	472039
12" Wired	472040

### Panel Kit (excludes Fan Core)

Size	Stock Ref
9" Wired	472051
12" Wired	472052

## Controller



### Models

Models	Stock Ref
Wired	455873

## Dimensions (mm)

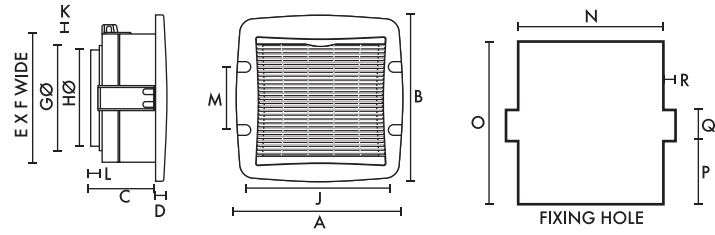

Size	9 in	12 in	Size	9 in	12 in
A	391	470	J	345	422
B	388	467	K	19	19
C	129	152	L	22	22
D	39	41	M	180	180
E	302	378	N	309	386
F	304	381	O	326	402
GØ	255	334	P	126	164
HØ	247	325	Q	55	55

Weight kg\*: 9mm - 5.13, 12mm - 7.44

\*Complete product. Controller (W x H x D) 97 x 99 x 32

## Performance Guide

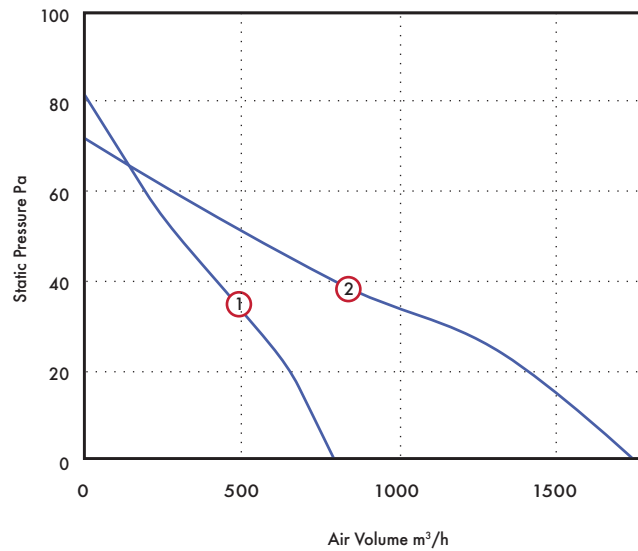

Model	Curve	Extract performance m³/h (l/s)			Watts (high)	Sound dB(A) (med) @ 3m	Amps @ 240V
		low	medium	high			
Lo-Carbon 9" Panel - Wired	1	357 (100)	601 (166)	799 (221)	30	41	0.33
Lo-Carbon 12" Panel - Wired	2	737 (205)	1487 (413)	1761 (490)	67	48	0.70

# Traditional T-Series Range Overview

- Available as wall, window, panel, roof, inline or Darkroom models
- Available as a complete unit or modular fan core and fitting kit for refurbishments
- Flexible installation design
- Simple installation



## ErP Regulations

The introduction of the ErP regulations gave us the opportunity to review our product ranges and has enabled us to improve the way we stock and sell them. You can still buy the market leading T-Series in the same way you always have, as a complete product, however we have taken the opportunity to add a more flexible option if you need it. We have introduced a modular option for refurbishment situations where you may not want to replace the whole product.

For new build projects and complete building refits the market leading T-Series is unchanged and available as a complete unit generally supplied in one carton.

For refurbishment markets, supplying as separate core and specific fitting kit gives more flexibility in both stocking and installing the product. This also gives the lowest overall cost to refurbish your fan system without changing wiring or controls, furthermore it also supports our Lo-Carbon drive to reduce waste and landfill.

## Complete Product Option

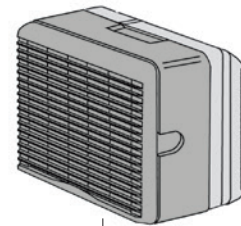

Complete product

## Modular option

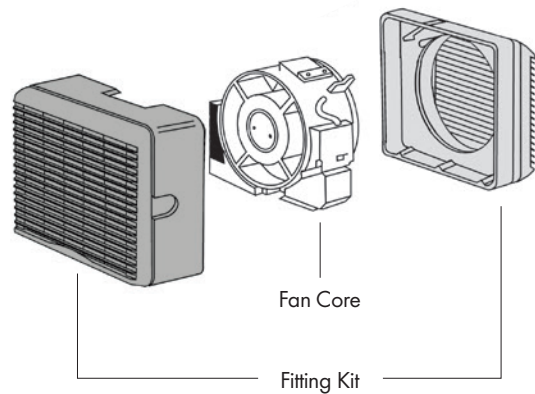

### Traditional T-Series Complete Fan

						
Size	Window Stock Ref	Wall Stock Ref	Roof Stock Ref	Panel Stock Ref	Darkroom Stock Ref	In-line Stock Ref
6"	W161110B	W161510B	W161210B	W161610B	W161240B	W161710B
7"	W162110B	W162510B	W162210B	W162610B	W162240B	N/A
9"	W163110B	W163510B	W163210B	W163610B	W163240B	W163710B
12"	W164110B	W164510B	W164210B	W164610B	W164240B	W164710B

### Traditional T-Series Modular Option



Fitting Kit Options (excludes Fan Core)

Size	Fan Core	Fitting Kit Options (excludes Fan Core)					
	Stock Ref	Window Stock Ref	Wall Stock Ref	Roof Stock Ref	Panel Stock Ref	Darkroom Stock Ref	In-line Stock Ref
6"	472012	472020	472016	472028	472024	472032	472036
7"	472013	472021	472017	472029	472025	472033	N/A
9"	472014	472022	472018	472030	472026	472034	472037
12"	472015	472023	472019	472031	472027	472035	472038

# Traditional T-Series Window Fan

- Extract/intake fans in 4 sizes: 6", 7", 9" and 12"
- Patented electronic shutter system ensures quiet, trouble free operation
- To obtain the best from your fan, use the Ecotronic controller
- Shutter open/fan off mode
- Low sound levels
- Easy fit connector Top Socket, standard on all models
- Designed for single or double glazing up to 32mm thick



## UK's No. 1 Commercial Fan

The T-Series fan range is fitted with a Vent-Axia M-Tech motor, developed to improve performance, lower running costs and maintain the T-Series' rugged reliability. A patented speed control pack is simply plugged in one of 3 positions to provide low, medium or boost speed matching the fan performance to the requirements of the installation.

## Instantaneous Shutter

With energy saving in mind T-Series Fitting Kits are supplied complete with an integral instantaneous automatic louvre shutter concealed behind the interior grille. It operates on both extract and intake and at any angle of mounting.

When the fan is used with a T-Series or Ecotronic controller, the shutter can be set open with the fan motor switched off to provide natural ventilation without the security risk of an open window.

## Top Socket

A connector Top Socket is standard on all T-Series fans allowing fast and trouble-free mains connection.

## Easy Cleaning

Integrated component design allows all parts to be dismantled for cleaning without the use of specialist tools.

## Electrical

Motor purpose-designed. Suitable for running at any angle. Quiet running. Suitable for operation in ambient temperatures from -40°C to +50°C.

Fitted with Standard Thermal Overload Protection (S.T.O.P.).

Supply voltage 220-240V/1/50Hz.

## Window Kit

Designed for use in single or double glazing, most types of glass and materials up to 32mm thick. Greater thicknesses can be accommodated using Extended Fixing Rod Sets. Can also be mounted in a fixing plate or wall, in ducts or above ceilings.

## Models

### Complete Fan

Model	Stock Ref
TX6WW	W161110B
TX7WW	W162110B
TX9WW	W163110B
TX12WW	W164110B

### Fan Core (excludes Fitting Kit)

Size	Stock Ref
TX6	472012
TX7	472013
TX9	472014
TX12	472015

### Window Kits (excludes Fan Core)

Size	Stock Ref
TX6	472020
TX7	472021
TX9	472022
TX12	472023

## Accessories

### Extended Fitting Rod set

Size	Stock Ref
6/7/9"	568104
12"	568106

## Controllers



Ecotronic Controller Surface Mounting

Stock Ref

W362320



T-Series Controller Surface Mounting

Stock Ref

W361119

## Dimensions (mm)

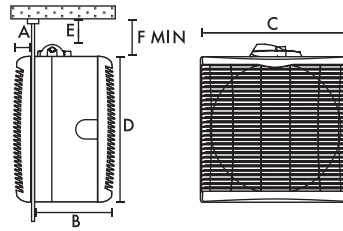

Size Dim.	6 in	7 in	9 in	12 in
A	31	31	39	41
B	130	130	150	177
C	226	265	304	381
D	220	258	302	378
E	19	19	19	19
F	54	54	54	54
Fixing hole Ø	184	222	260	337
Weight kg*	3.57	3.93	5.35	7.7

\*Complete product.

## Performance Guide

Model	Extract performance m <sup>3</sup> /h (l/s)			Watts (high)	Sound dB(A) (med) @ 3m	Amps @ 240V
	low	medium	high			
TX6 Window	245 (68)	315 (88)	360 (100)	30	41	0.24
TX7 Window	305 (85)	395 (110)	485 (135)	40	37	0.24
TX9 Window	465 (130)	685 (190)	795 (220)	85	43	0.42
TX12 Window	1095 (305)	1415 (393)	1615 (449)	105	48	0.51



# Traditional T-Series Wall Fan

- Extract/intake model in 4 sizes: 6", 7", 9" and 12"
- Patented electronic shutter system ensures quiet, trouble free operation
- For the very best from your fan use the Ecotronic controller
- Easy fit connector Top Socket, standard on all models



## UK's No. 1 Commercial Fan

Behind the grille of the Vent-Axia T-Series Wall model is a range of high performance extract/intake fans designed to fit through most wall thicknesses using telescopic liners supplied.

T-Series also features a unique speed control pack which enables high, medium or low speed to be preset to suit room size or required duty.

T-Series controllers may be used with this model to obtain a choice of speeds, reversible airflow direction and automatic sensor operation. The Vent-Axia Ecotronic controller gives even greater running economy with its minimum speed setting and 'E' mode.

## Top Socket

A connector Top Socket is standard on all T-Series fans. Allowing fast and trouble-free mains connection.

## Shutter

TX models are supplied complete with an integral instantaneous automatic louvre shutter which will operate on both intake and extract and at any angle of mounting.

When the fan is used with a T-Series or Ecotronic controller, the shutter can be set open with the fan motor switched off to provide natural ventilation without the security risk of an open window.

## Electrical

Motor purpose-designed. Suitable for running at any angle. Quiet running, enclosed. Suitable for operation in ambient temperatures from -40°C to +50°C.

Fitted with Standard Thermal Overload Protection (S.T.O.P.).

Supply voltage 220-240V/1/50Hz.

## Wall Kits

Designed to fit into most double brick walls using the telescopic liners, supplied. Additional liners are available to accommodate exceptionally thick brick walls.

## Models

### Complete Fan

Model	Stock Ref
TX6WL	W161510B
TX7WL	W162510B
TX9WL	W163510B
TX12WL	W164510B

### Fan Core (excludes Fitting Kit)

Size	Stock Ref
TX6	472012
TX7	472013
TX9	472014
TX12	472015

### Wall Kits (excludes Fan Core)

Size	Stock Ref
TX6	472016
TX7	472017
TX9	472018
TX12	472019

## Accessories

### Additional Wall Liner Section

Size	Stock Ref
TX6	460094
TX7	460095
TX9	460096
TX12	460086

## Controllers



Ecotronic Controller Surface Mounting

Stock Ref

W362320



T-Series Controller Surface Mounting

Stock Ref

W361119

## Dimensions (mm)

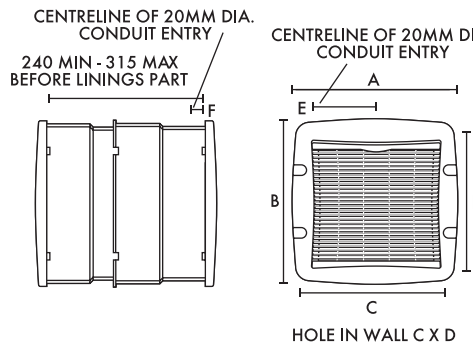

Size Dim.	6 in	7 in	9 in	12 in
A	310	352	391	470
B	303	345	388	467
C	290	330	365	442
D	290	330	375	450
E	104	124	143	182
F	25	25	25	25
Weight kg	5.54	6.13	7.77	10.86

\* Complete product.

## Performance Guide

Model	Extract performance m <sup>3</sup> /h (l/s)			Watts (high)	Sound dB(A) (med) @ 3m	Amps @ 240V
	low	medium	high			
TX6 Wall	270 (75)	350 (97)	395 (110)	40	43	0.24
TX7 Wall	335 (93)	435 (120)	530 (147)	40	39	0.24
TX9 Wall	515 (143)	755 (210)	870 (241)	85	43	0.42
TX12 Wall	1185 (329)	1530 (425)	1745 (485)	105	49	0.51

# Traditional T-Series Roof Fan

- Extract/intake model in 4 sizes: 6", 7", 9" and 12"
- Patented electronic shutter system ensures quiet, trouble free operation
- For the very best from your fan use the Ecotronic controller
- T-Series controllers and sensors save energy by only switching on the units when you want, either manually or automatically
- Easy fit connector Top Socket, standard on all models



## UK's No. 1 Commercial Fan

With a low profile cowl, the T-Series Roof model is suitable for installation in horizontal, angled (max pitch 30deg) and vertical glass and for fixing plates in roofs. For vertical windows or walls in exposed areas and single or double glazing including most types of glass up to 32mm thick. Greater thicknesses can be accommodated using extended fixing rod sets. All four sizes of Vent-Axia roof plate assemblies can be fitted easily into flat roofs.

T-Series features a unique speed control pack which enables high, medium or low speed to be preset to suit room size or required duty. When used with a T-Series TSC controller, the speed control pack is removed from the T-Series fan and fitted into the 3-pin socket in the back of the controller. The Vent-Axia Ecotronic controller gives even greater running economy with its minimum speed setting and 'E' mode. When using the Ecotronic controller the speed control pack remains in the fan.

## Shutter

With energy saving in mind, T-Series Fitting Kits are supplied complete with an integral instantaneous automatic louvre shutter concealed behind the interior grille. It will operate on both intake and extract and at any angle of mounting.

When the fan is used with a T-Series or Ecotronic controller, the shutter can be set open with the fan motor switched off to provide natural ventilation without the security risk of an open window.

## Electrical

Motor purpose-designed. Suitable for running at any angle. Quiet running, enclosed. Suitable for operation in ambient temperatures from -40°C to +50°C.

Fitted with Standard Thermal Overload Protection (S.T.O.P.).

Supply voltage 220-240V/1/50 Hz.

## Top Socket

A connector Top Socket is standard on all T-Series fans. Allowing fast and trouble-free mains connection.

## Models

### Complete Fan

Model	Stock Ref
TX6RF	W161210B
TX7RF	W162210B
TX9RF	W163210B
TX12RF	W164210B

### Fan Core (excludes Fitting Kit)

Size	Stock Ref
TX6	472012
TX7	472013
TX9	472014
TX12	472015

### Roof Kit (excludes Fan Core)

Size	Stock Ref
TX6	472028
TX7	472029
TX9	472030
TX12	472031

## Controllers



Ecotronic Controller Surface Mounting

Stock Ref

W362320



T-Series Controller Surface Mounting

Stock Ref

W361119

## Dimensions (mm)

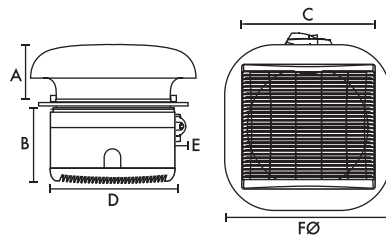

Size Dim.	6 in	7 in	9 in	12 in
A	100	136	136	171
B	130	130	150	177
C	226	265	304	381
D	220	258	302	378
E	54	54	54	54
F Ø	285	400	400	500
Fixing Hole Ø	184	222	260	337
Weight kg*	3.96	4.89	6.22	9.28

\*Complete product.

## Performance

Model	Extract performance m <sup>3</sup> /h (l/s)			Watts (high)	Sound dB(A) (med) @ 3m	Amps @ 240V
	low	medium	high			
TX6 Roof	195 (55)	250 (70)	290 (80)	30	41	0.24
TX7 Roof	305 (85)	395 (110)	485 (135)	40	37	0.24
TX9 Roof	465 (130)	685 (190)	795 (220)	85	43	0.42
TX12 Roof	1010 (280)	1305 (362)	1485 (412)	105	48	0.51

# Traditional T-Series Panel/Ceiling Fan

- Extract/intake model in 4 sizes: 6", 7", 9" and 12"
- Colour: soft tone grey
- Patented electronic shutter system ensures quiet, trouble-free operation
- For the very best from your fan use the Ecotronic controller
- East fit connector Top Socket, standard on all models



## UK's No. 1 Commercial Fan

Vent-Axia T-Series Panel/Ceiling models are suitable for mounting at any angle in internal partitions, ceilings, ducts and, with louvre grilles, through external walls. When installed only the louvre grille is visible. The range features a unique speed control pack which enables high, medium or low speed to be preset to suit a specific room size or required duty.

T-Series controllers may be used with this model to obtain a choice of speeds, reversible airflow direction and automatic sensor operation. When used with a controller, the speed control pack is removed from the T-Series fan and fitted into the 3-pin socket in the back of the controller. The Vent-Axia Ecotronic controller gives even greater running economy with its minimum speed setting on 'E' mode and infinitely variable speed control. For this controller the speed control pack remains in the fan.

## Electrical

Suitable for operation in ambient temperatures from -40°C to +50°C.

Fitted with Standard Thermal Overload Protection (S.T.O.P).

Supply voltage: 220-240V/1/50Hz.

## Top Socket

A connector Top Socket is standard on all T-Series fans allowing fast and trouble-free mains connection.

## Shutter

With energy saving in mind, panel/ceiling kits are supplied complete with an integral instantaneous automatic louvre shutter concealed behind the interior grille. It will operate on both intake and extract and at any angle of mounting.

When the fan is used with a T-Series or Ecotronic controller, the shutter can be set open with the fan motor switched off to provide natural ventilation without the security risk of an open window.

## Models

### Complete Fan

Model	Stock Ref
TX6PL	W161610B
TX7PL	W162610B
TX9PL	W163610B
TX12PL	W164610B

### Fan Core (excludes Fitting Kit)

Size	Stock Ref
TX6	472012
TX7	472013
TX9	472014
TX12	472015

### Panel/Ceiling Kit (excludes Fan Core)

Size	Stock Ref
TX6	472024
TX7	472025
TX9	472026
TX12	472027

## Controllers



### Ecotronic Controller Surface Mounting

Stock Ref  
W362320



### T-Series Controller Surface Mounting

Stock Ref  
W361119

## Dimensions (mm)

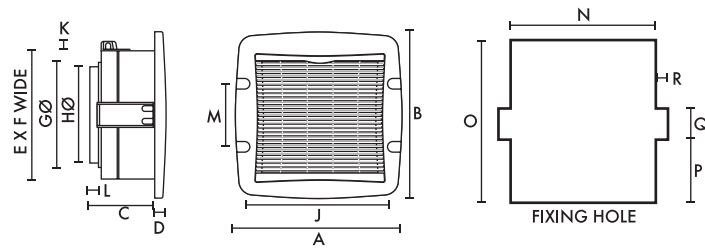

Size Dim.	6 in	7 in	9 in	12 in
A	310	352	391	470
B	303	345	388	467
C	117	117	129	152
D	32	32	39	41
E	220	258	302	378
F	226	265	304	381
GØ	180	218	255	334
HØ	171	210	247	325
J	267	306	345	422
K	19	19	19	19
L	22	22	22	22
M	180	180	180	180
N	231	270	309	386
O	244	282	326	402
P	85	104	126	164
Q	55	55	55	55
R	12	12	12	12
Weight kg*	3.50	3.82	5.13	7.44

\* Complete product.

## Performance Guide

Model	Extract performance m <sup>3</sup> /h (l/s)			Watts (high)	Sound dB(A) (med) @ 3m	Amps @ 240V
	low	medium	high			
TX6 Panel/Ceiling	295 (81)	380 (105)	435 (120)	30	41	0.24
TX7 Panel/Ceiling	365 (101)	480 (133)	585 (162)	40	37	0.24
TX9 Panel/Ceiling	565 (157)	830 (230)	960 (267)	85	43	0.42
TX12 Panel/Ceiling	1270 (353)	1640 (456)	1885 (524)	105	44	0.51

# Traditional T-Series Darkroom Fan

- Extract/intake models in 4 sizes: 6", 7", 9" and 12"
- Specially designed to provide extract/intake ventilation in darkrooms, X-ray areas, etc
- Patented electronic shutter system ensures quiet, trouble free operation
- For the very best from your fan use the Ecotronic controller
- Integrated component design allows all parts to be dismantled for cleaning without the use of specialist tools
- Easy fit connector Top Socket, standard on all models



## UK's No. 1 Commercial Fan

A range designed for photographic, medical, dental and veterinarian applications, also for opticians and other specialist applications. Most darkrooms need a minimum of ten air changes per hour for comfort and efficiency. For rooms containing heat producing equipment (eg: print glazers) a higher rate of air change may be desirable.

The Darkroom fitting kit has two cowls, the interior cowl being designed to give light protection. It can be installed in windows, partitions, external walls or roofs. Extended fixing rods for fixing thicknesses up to 370mm are supplied with the unit. Provision should be made for adequate air replacement through Vent-Axia non-vision grilles.

## Shutter

With energy savings in mind Darkroom models are supplied complete with an integral instantaneous automatic louvre shutter concealed behind the interior cowl. Operates on intake and extract at any angle of mounting.

When used with a T-Series or Ecotronic controller, the shutter can be set open with the fan motor switched Off to provide natural ventilation without the security risk of an open window.

## Top Socket

A connector Top Socket is standard on all T-Series fans. Allowing fast and trouble-free mains connection.

## Electrical

Suitable for running at any angle. Quiet running, enclosed. Fitted with Standard Thermal Overload Protection (S.T.O.P.).

Supply voltage: 220-240V/1/50Hz.

Suitable for operation in ambient temperatures from -40°C to +50°C.

## Models

### Complete Fan

Model	Stock Ref
TX6DR	W161240B
TX7DR	W162240B
TX9DR	W163240B
TX12DR	W164240B

### Fan Core (excludes Fitting Kit)

Size	Stock Ref
TX6	472012
TX7	472013
TX9	472014
TX12	472015

### Darkroom Kit (excludes Fan Core)

Size	Stock Ref
TX6	472032
TX7	472033
TX9	472034
TX12	472035

## Controllers



### Ecotronic Controller Surface Mounting

Stock Ref  
W362320



### T-Series Controller Surface Mounting

Stock Ref  
W361119



## Dimensions (mm)

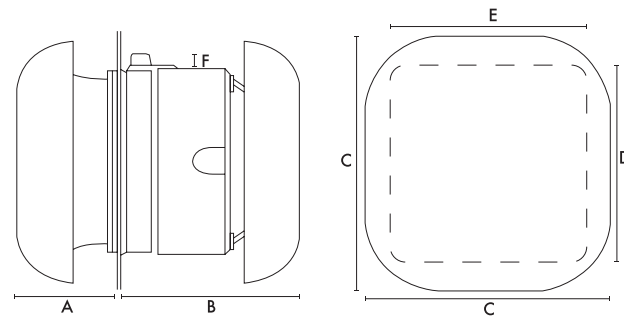

Size Dim.	6 in	7 in	9 in	12 in
A	100	136	136	171
B	196	206	229	308
C	285	400	400	500
D	220	258	302	378
E	226	265	304	381
F	19	19	19	19
Fixing Hole Ø	184	222	260	337
Weight kg*	4.13	5.33	6.60	10.05

\*Complete product.

## Performance Guide

Model	Extract performance m <sup>3</sup> /h (l/s)			Watts (high)	Sound dB(A) (med) @ 3m	Amps @ 240V
	low	medium	high			
TX6 Darkroom	200 (55)	240 (67)	265 (74)	30	43	0.24
TX7 Darkroom	330 (92)	415 (115)	530 (147)	40	42	0.24
TX9 Darkroom	455 (126)	630 (175)	725 (201)	85	45	0.42
TX12 Darkroom	870 (242)	1040 (289)	1130 (314)	105	42	0.51

# Traditional T-Series In-Line Fan

- Extract/intake model in 3 sizes: 6", 9" and 12"
- Patented instantaneous electronic shutter system ensures quiet, trouble free operation
- For the best from your fan use the Ecotronic controller
- T-Series controllers and sensor save energy by only switching on the units when you want, either manually or automatically
- Easy fit connector Top Socket, standard on all models



## UK's No. 1 Commercial Fan

No other range of high performance in-line duct fans offers a combination of 3 impeller diameters, reversibility, low sound level, speed control and built-in electric shutter. T-Series features a unique speed control pack which enables high, medium or low speed to be preset to suit room size or required duty. Designed for use with rigid or flexible ducting, T-Series In-Line models can be plate mounted or fixed through partitions and in ceiling voids.

T-Series controllers may be used with this model to obtain a choice of speeds, extract/intake airflow direction and automatic sensor operation. The Vent-Axia Ecotronic controller gives even greater running economy with its minimum speed setting and 'E' mode.

## Top Socket

A connector Top Socket is standard on all T-Series fans. Allowing fast and trouble-free mains connection.

## Shutter

The shutter is electronically controlled by an actuator with a damped action giving quiet operation during instant opening and closing. The interlocking edges of the shutter blades provide maximum back draught protection.

When the fan is used with a T-Series or Ecotronic controller, the shutter can be set open with the fan motor switched off to provide natural ventilation without the security risk of an open window.

## Ducts

Where ducts pass through an unheated roof void, the duct should be insulated. Horizontal ducts should fall away from the fan unit. In circumstances where an excessive amount of moisture is present, a condensation trap should be installed in the exhaust duct. The fan unit should be accessible for regular maintenance.

## Electrical

Suitable for operation in ambient temperatures from -40°C to +50°C.

Fitted with Standard Thermal Overload Protection (S.T.O.P.).

Supply voltage 220-240V/1/50 Hz.

## Models

### Complete Fan

Model	Stock Ref
TX6IL	W161710B
TX9IL	W163710B
TX12IL	W164710B

### Fan Core (excludes Fitting Kit)

Model	Stock Ref
TX6	472012
TX9	472014
TX12	472015

### In-line Kit (excludes Fan Core)

Model	Stock Ref
TX6	472036
TX9	472037
TX12	472038

For use with rigid and flexible ducting. Can be plate-mounted or fixed to partitions and in ceiling voids.

## Controllers



Ecotronic Controller Surface Mounting

Stock Ref

W362320



T-Series Controller Surface Mounting

Stock Ref

W361119

## Dimensions (mm)

Sizes 6 & 9

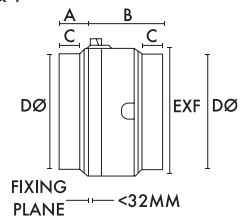

Size 12

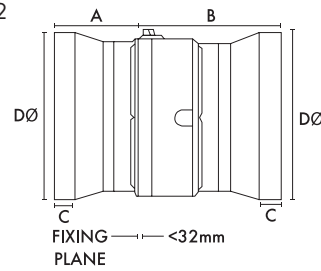

Size Dim.	6 in	9 in	12 in
A	75	71	200
B	175	183	337
C	45	41	45
DØ	175	300	400
E	220	302	378
F	226	304	381
Fixing Hole Ø	184	260	337
kg	4.5	8	11.5

## Performance Guide

Model	Extract performance m <sup>3</sup> /h (l/s)			Watts (high)	Sound dB(A) (med) @ 3m	Amps @ 240V
	low	medium	high			
TX6 In-line	318 (88)	398 (110)	444 (123)	30	45	0.24
TX9 In-line	703 (195)	966 (268)	1050 (292)	85	47	0.42
TX12 In-line	1674 (465)	2000 (556)	2230 (620)	105	51	0.51

# Super T-Series

- 4 impeller diameters 355, 400, 450, 500mm
- Complete with telescopic wall sleeve and shutter, ready for installation
- IP54 motor and terminal box
- Smart internal grille and external shutter with flange trim
- Super quiet operation
- For the very best performance from your fan, use the Vent-Axia 2.5 Amp electronic controller



## Powerful Ventilation

Vent-Axia's Super T-Series 355, 400, 450 and 500mm fans provide efficient, quiet powerful ventilation with performances up to 4940m<sup>3</sup>/h. Tough heavy duty internal grilles and external weather shutters ensure longevity, performance and peace of mind.

## Construction

The axial fan at the heart of the Super T range is based on an integrated impeller and internal rotor motor design which produces a very compact unit. A specially designed bellmouth inlet and mounting plate ensures an excellent performance to sound level ratio.

## Electrical

Single phase 220-240V 50Hz. Capacitor start and run. An IP54 terminal box is supplied with all models with conduit entry from the side of the wall liner. All motors are fitted with Standard Thermal Overload Protection (S.T.O.P.), which should be wired via the controller.

## Models

### Super T - Gravity shutter

When installed, only the room side aluminium fascia grille is visible. The outside is finished with an external gravity shutter and frame.

Model	Stock Ref
ST355-16-WL	165510A
ST400-16-WL	166510A
ST450-16-WL	167510A
ST500-16-WL	168510A

### Super T TX - Electric shutter

Super T TX extract or intake models with powerful, quiet, smooth-operation electric shutters.

Model	Stock Ref
STX355-16	165710A
STX400-16	166710A

STX450-16	167710A
STX500-16	168710A

## Super T Filtered Air Input

Super T ARX and AR filtered passive air replacement input unit. Consisting of a wall liner with high capacity high disposable EU4 pleated filter which fits inside the wall liner.

## ARX Models

With electronically controlled integral shutter AR Models - external louvre fixed blade.

Model	Stock Ref
Units with integral shutter	
STARX355-16	165810
STARX450-16	167810

## Units with louvre fixed blades

STAR355-16	165910
STAR450-16	167910

## Filtered Kitchen Extract - Super T GF

Super T GF extract unit without internal grille, but with matching stainless steel filter housing and tray kit ready for assembly on site and 50mm stainless steel framed mesh grease filter with handles.

Model	Stock Ref
STGF355-14	165620A
STGF400-14	166620A

## Accessories

### Replacement Grease Filters

Super T replacement grease filters 50mm stainless steel mesh filter with handles. Supplied in packs of two.

Model	Stock Ref
355	452550
400	452551

### Replacement Air Filters

High capacity EU4 pleated filter which fits inside wall liner. Supplied in packs of five.

<b>Model</b>	<b>Stock Ref</b>
355	<b>452814</b>
450	<b>452815</b>

### Electronic 2.5A Controller

Provides variable motor speed control. On/Off with indication light. Infinitely variable speed slider control. Presetable minimum speed and sensor mode option: can be connected to a range of Vent-Axia sensors. Radio suppressed to BS 800. Includes electric shutter output.

**Stock Ref**  
**W10303102M**

### Dimensions (mm)

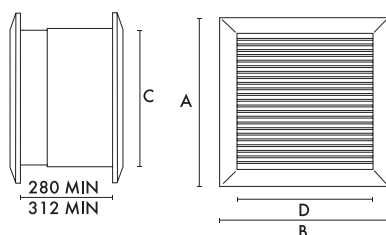

Impeller dia.	355	400	450	500
A	550	597	657	727
B	550	597	657	727
C	470	520	580	650
D	470	520	580	650
Weight kg	17	22	28	33

### Performance Guide

Model	Extract Performance m <sup>3</sup> /h (l/s) F.I.D.	Watts	S.C. amps	F.L.C. amps	Sound dB(A) @ 3m
355-16	1800 (500)	130	1.38	0.6	40
400-16	2034 (565)	90	1.2	0.46	45
450-16	2561 (761)	100	1.4	0.48	48
500-16	4378 (1216)	360	3.6	1.6	51
355-14	2150 (597)	150	1.38	0.7	56
400-14	3500 (972)	190	1.45	0.84	59

# Accessories & Controllers



For ventilation systems to be truly efficient it is important for them to operate only when needed. Our range of Sentinel demand ventilation systems along with our controls and sensors help respond to the exact ventilation requirements of a room at any one time. Providing airflow only when it is required and at the level that it is required ensures that only the energy that is needed is used; no more, no less.

Approved Document L recognises the value that controls can offer and you will find Vent-Axia offers a range of solutions to ensure that you can maximise the benefit of automation wherever you chose to use it.

**Vent-Axia**<sup>®</sup>

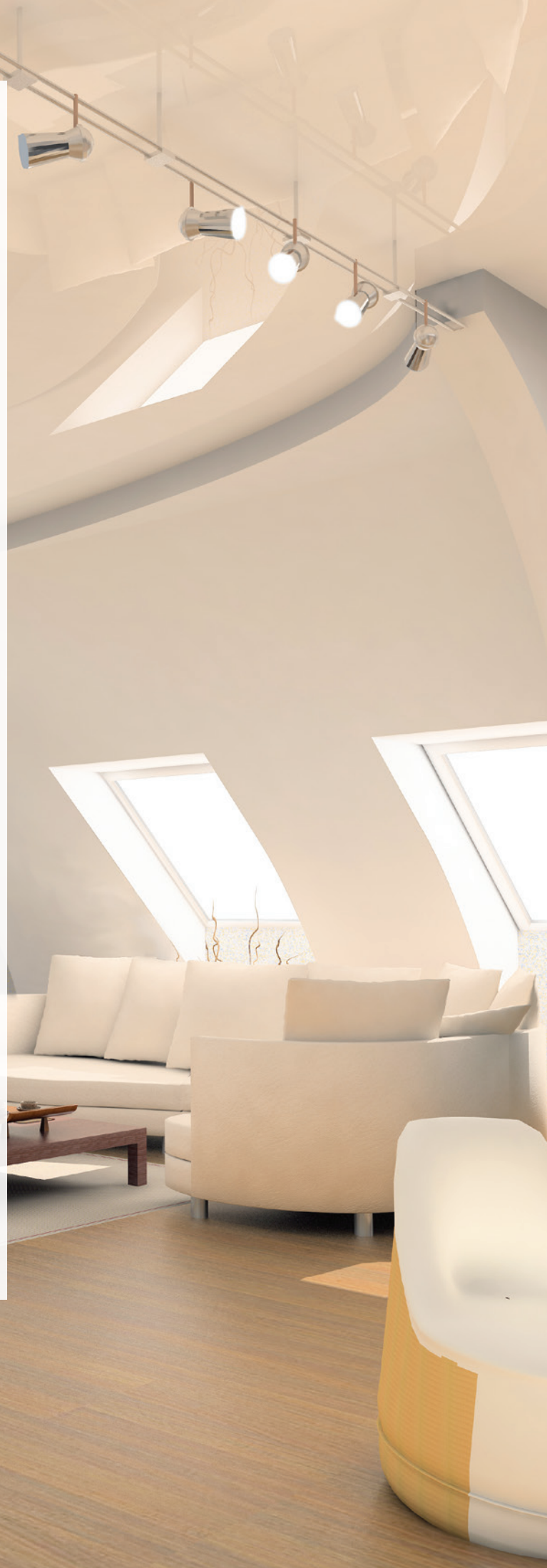



Controllers and Sensors

13-110

---



Ventilation Accessories

111-118

---



# Controllers & Sensors



## Ecotronic Controller Surface Mounting

An electronic controller for use with all Traditional T-Series and Standard Range models to give extract/intake and speed variation. For groups of units of any one size up to a total of 400 Watts. Do not mix T-Series with Standard Range. Where a controller is used with T-Series, 5-core flexible cable is required.

- 'E' running position for optimum efficiency.
- Finger-tip sliders.
- Infinitely variable speed control.
- Double pole On/Off switching.
- Extract/intake airflow direction.
- Neon indicator.
- Sensor mode for use with suitable electromechanical switches, eg. ThermoSwitch, HumidiSwitch to give automatic fan operation.
- Adjustable minimum speed setting.
- Knockouts for recessed wiring.
- Ambient operating temperature range 0°C to +40°C.
- Dimensions: 86 x 156 x 53mm (H x W x D).
- Supply voltage 220-240V/1/50Hz.
- Maximum load: Ecotronic - 400 Watts.
- Designed to meet IP20.
- BEAB approved.

Stock Ref  
**W362320**

Flush Fitting Box  
Stock Ref  
**400144**

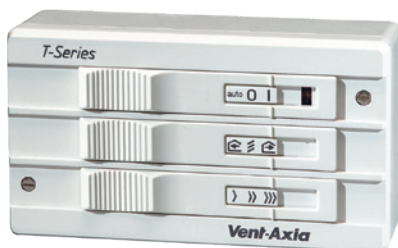

## T-Series® Controller Surface Mounting

A single unit controller for use with all Traditional T-Series ventilating units. With knockouts for recessed wiring. Where a controller is used with T-Series, 5-core flexible cable is required.

- 3-speed operation. High, medium or low.
- Finger-tip sliders.
- Double pole On/Off switching.
- Extract/intake airflow direction.
- Sensor mode for use with suitable electromechanical switches, eg. ThermoSwitch, HumidiSwitch to give automatic fan operation.
- Unique shutter open/ fan Off setting.
- Neon indicator.
- Knockouts for recessed wiring.
- Ambient operating temperature range 0°C to +40°C.
- Dimensions: 86 x 156 x 53mm (H x W x D).
- Supply voltage 220-240V/1/50Hz.
- Designed to meet IP20.
- BEAB approved.

Stock Ref  
**W361119**

Flush Fitting Box  
Stock Ref  
**400144**



## TimeSpan® Controller

Adjustable timer with overrun facility for fans ventilating WCs and other small rooms.

For use with any Vent-Axia fan within maximum rating below. The fan is switched On with the light and keeps running for a pre-set period after the light is switched Off.

- Fits to any single gang box.
- Adjustable time delay 5-25 minutes.
- Ambient operating temperature range 0°C to + 40°C.
- Maximum load 250W inductive.
- BEAB approved.
- Dimensions: 87 x 87 x 33mm (H x W x D).
- Supply voltage 220-240V/1/50Hz.
- Will fit single gang box for surface mounting.

Stock Ref  
**563519**

Surface Mounting Box  
A surface mounting back box is available.  
Stock Ref  
**410020**

Registered design numbers: 1 030 207 Surface Mounting Controller, 1 030 208 Flush Fitting Controller. Patented Remote Speed Control Circuit. European Patent number EP 0180311.



### Air Quality Sensor

Automatically reacts to the depletion of air quality, sensing unpleasant smells and toilet odours to regulate mechanically ventilated areas such as cinemas, pubs, clubs, restaurants, kitchens, toilets and conference rooms. This is not a CO<sub>2</sub> sensor.

The sensor switches the fan On when the air quality declines below an adjustable preset level. This is registered by the ceramic sensing head which is self-cleaning, a process which occurs every time the unit is triggered. When the atmosphere has returned to normal, the fan will continue to run for a pre-set period (adjustable between 1-25 minutes) and then switch Off.

The air quality sensor should not be used for the detection of combustible gases and is not designed for use as a smoke detector in an alarm system.

For use with various Vent-Axia fans within maximum rating below.

The Air Quality Sensor is also able to switch between trickle and boost speed on the appropriate ventilation units.

- Ambient operating temperature range 0°C to +50°C.
- Dimensions: 87 x 157 x 47mm (H x W x D).
- Maximum switched load: 2A inductive at 240V.
- Sensor consumption: 25mA at 240V.
- Supply voltage 240V/1/50Hz.

Stock Ref  
563506



### Electronic 1.5A Controller

Surface mounted, providing infinitely variable speed control and features an On/Off/sensor slider with neon indicator. There is an adjustable minimum speed setting. The controller is radio suppressed to BS EN 55014 and electrical connections for use with suitable external sensors are provided.

86 x 156 x 53mm (H x W x D).

Hole for wall box:  
80x150x150mm (H x W x D).

Stock Ref  
W300310

For flush fitting a metal wall box accessory is available.

Flush fitting box  
Stock Ref  
400144



### HR500 Controller

Suitable for use with HR500 MVHR units. Surface mounting. On/Off remote sensor mode. Heat exchange, single fan extract or twin fan extract modes. Infinitely variable speed. Minimum speed setting.

Stock Ref  
W14301010

# Controllers & Sensors



## Ambient Response Humidity Sensor

A self programming electronic On/Off wall mounted humidity sensor which reacts to any rapid increase in humidity and temperature by switching a Vent-Axia fan 'On' for rapid removal of moisture laden air in domestic bathrooms and kitchens. Can be wired into controller 'Auto' mode connections. Night time relative humidity increment setback feature suppresses nuisance tripping when the humidity level gradually rises as the temperature falls.

- Pullcord override and neon indicator.
- Changeover relay switch.
- Operating range: 30%-90%RH.
- Ambient operating temperature +5°C to +40°C.
- Dimensions: 87 x 87 x 33mm (H x W x D).
- Will fit single gang box for surface mounting.

### Stock Ref

**563550A** 240VAC 50Hz

European Patent No: 2298057

### Surface Mounting Box

A surface mounting back box is available.

### Stock Ref

**410020**



## Ambient Response SELV 12 Humidity Sensor

12V Safety Extra Low Voltage version for use with VA100 SELV, Solo SELV, LuminAir SELV and HR100 SELV range.

The latest self programming electronic On/Off wall mounted humidity sensor which reacts to any rapid increase in humidity and temperature by switching a Vent-Axia fan 'On' for rapid removal of moisture laden air in domestic bathrooms and kitchens. Can be wired into controller 'Auto' mode connections. Night time relative humidity increment setback feature suppresses nuisance tripping when the humidity level gradually rises as the temperature falls.

- Pullcord override and neon indicator.
- Changeover relay switch.
- Operating range: 30%-90%RH.
- Ambient operating temperature +5°C to +40°C.
- Dimensions: 87 x 87 x 33mm (H x W x D).
- Will fit single gang box for surface mounting.

### Stock Ref

**563551A** 12VAC 50Hz

### Surface Mounting Box

A surface mounting back box is available.

### Stock Ref

**410020**



## Lo-Carbon Ambient Response Humidity Sensor

Designed specifically for the Lo-Carbon product range. This self programming electronic On/Off wall mounted humidity sensor reacts to any rapid increase in humidity and temperature by switching a Vent-Axia fan 'On' for rapid removal of moisture laden air in domestic bathrooms and kitchens. Night time relative humidity increment setback feature suppresses nuisance tripping when the humidity level gradually rises as the temperature falls.

- Pullcord override and neon indicator.
- Changeover relay switch.
- Operating range: 30%-90%RH.
- Ambient operating temperature +5°C to +40°C.
- Dimensions: 87 x 87 x 33mm (H x W x D).
- Will fit single gang box for surface mounting.

### Stock Ref

**563552A** 12VDC

### Surface Mounting Box

A surface mounting back box is available.

### Stock Ref

**410020**

All of these Sensors can be wired for either On/Off or Trickle/Boost operation.



### Ecotronic Humidity Sensor Surface Mounting

An adjustable set point, solid state On/Off sensor. A pullcord provides manual override, indicated by lamp. Adjustable from 65 to 90% relative humidity. Can be wired into controller 'Auto' mode connections. Incorporates changeover switch to select low/high speed.

- Setting range 65% - 90%RH.
- Maximum switching load 1 Amp inductive.
- Pullcord override indicated by lamp.
- Ambient operating temperature 0°C to +40°C.
- Dimensions: 87 x 87 x 33mm. (H x W x D).
- Supply voltage 220-240V/1/50Hz.

Stock Ref  
**563532**

**Surface Mounting Box**  
A surface mounting back box is available.  
Stock Ref  
**410020**



### Ecotronic® SELV 12 Humidity Sensor

12V Safety Extra Low Voltage version for use with VA100 SELV, Solo SELV, and LuminAir SELV range. Incorporates changeover switch to select low/high speed.

Although suitable for siting within reach of a shower or bath we recommend this model is located out of the spray zone of a bath or shower.

- Setting range 65% - 90%RH.
- Maximum switching load 5.6A @ 12V AC.
- Pullcord override indicated by lamp.
- Ambient operating temperature 0°C to +40°C.
- Dimensions: 87 x 87 x 33mm (H x W x D).
- Supply voltage 12V AC.

Stock Ref  
**563531A**

**Surface Mounting Box**  
A surface mounting back box is available.  
Stock Ref  
**410020**



### Vent-Axia HumidiSwitch

Operates Vent-Axia ventilating units on either a rise or a fall in humidity to control the damaging effects of condensation.

- Concealed adjustment.
- Setting range 20% to 80% RH.
- Ambient operating temperature 0°C to +50°C.
- Dimensions: 82 x 132 x 40mm (H x W x D).
- Rating 2A (1A inductive).
- Switching range 120-240V.
- Designed for use with controllers with 'Auto' mode facility.
- Single pole changeover contacts.

Stock Ref  
**563501**

The Ecotronic and Ecotronic SELV 12 Sensor can be wired for either On/Off or Trickle/Boost operation.

# Controllers & Sensors



## 7 Day TimeSwitch

For applications where regular switching is required at fixed periods or at different times on different days of the week, eg: offices, shops, pubs and restaurants.

The 7-day TimeSwitch gives twelve On or Off positions per day and can be set for 7 days. The cycle will repeat until changed.

- Analogue clock display and integral time switches for ease of setting.
- Manual override.
- Removable clear plastic cover protects TimeSwitch face.
- Volt free changeover contacts.
- Time base: 7 days.
- Shortest switching time: 2 hours.
- Maximum load: 16amp resistive (8amp inductive).
- Ambient operating temperature range -20°C to +85°C.
- Dimensions: 104 x 74 x 52mm (H x W x D).
- Supply voltage 220-240V/1/50Hz.

Stock Ref  
**563515A**



## Vent-Axia ThermoSwitch

Automatically switches On fans on either a rise or fall in air temperature. The ThermoSwitch can be used with all Vent-Axia fans (via switch gear if appropriate) for the removal of warm air from buildings. It can also be used to switch On Hi-Line ceiling fans for summer cooling and to move high level warm air down to the working level during winter.

- Setting range: +6°C to +30°C.
- Two internal range limit/locking rings are included to allow setting within a limited temperature range or locking at a fixed t/o point.
- IP20 rated.
- Sealed sensing mechanism.
- Snap-action, single pole, changeover contacts.
- Mounting direct on surface only.
- Electrical connection to screw type terminals with rear or side cable entry.
- Dimensions: 80 x 104 x 36mm (H x W x D).
- Contact rating: 1.5 amp (inductive).
- 16 amps (resistive).
- Maximum voltage 250V.

Stock Ref  
**563502B**



## Guardian Personnel Detector (PIR Sensor)

Suitable for controlling a range of Vent-Axia fans. Continuously monitors an area and activates when a moving body is detected.

- Supplied complete with wall mounting bracket.
- Adjustable timer overrun (5 seconds to 20 minutes).
- Supplied with lens to provide 15m (max) range, 200° detection area.
- Designed to meet IP55.
- Ambient operating temperature range -20°C to +50°C.
- Maximum load: 10 amp resistive (5 amp inductive).
- Suitable for use with fluorescent lighting up to 500W.
- Internal/External use.
- Supply voltage 220-240V/1/50Hz.

Stock Ref  
**563548**

7 day Time Switch & ThermoSwitch can be wired for either On/Off or Trickle/Boost operation.



### Vent-Axia Visionex PIR

A wall or ceiling mounted movement detector for use with any domestic Vent-Axia mains voltage product. Also suitable for use with Vent-Axia T-Series controllers on 'Auto' setting and ITC controllers on sensor mode. Visionex PIR can be wired for either On/Off or Trickle/Boost operation.

- Fits any UK single gang mounting box.
- Adjustable timer overrun (5-25 minutes).
- Range of detection up to 10 metres.
- Designed to meet IP43.
- Ambient operating temperature range 0°C to +50°C.
- Maximum load: 2.5 amps/600W inductive. Not suitable for use with lighting.
- Internal use only.
- No switched live required for internal rooms and WCs.
- Double insulated.
- Volt-free contacts.
- Supply voltage 220-240V/1/50Hz.

Stock Ref  
**459623B**

#### Surface Mounting Box

A surface mounting back box is available.

Stock Ref  
**410020**



### Vent-Axia Visionex SELV 12 PIR

A wall or ceiling mounted movement detector for use with any domestic Vent-Axia SELV 12 product.

- Fits any UK single gang mounting box.
- Adjustable timer overrun (5-25 minutes).
- Range of detection up to 10 metres.
- Designed to meet IP43.
- Ambient operating temperature range 0°C to +50°C.
- Maximum load: 5.6 amps inductive @ 12V.
- Internal use only.
- No switched live required for internal rooms and WCs.
- Class III product.
- Volt-free contacts.
- Supply voltage 12V/1/50Hz.

Stock Ref  
**459624B**

#### Surface Mounting Box

A surface mounting back box is available.

Stock Ref  
**410020**



### 5 Step Auto Controller

Used in conjunction with speed controllable fans to provide 5 stepped speed without electronic motor 'hum'. Several fans can be connected to one transformer provided their combined load does not exceed the controller rating.

Single phase: 3.5, 6.0 and 7.5 amp. Rotary switch giving On/Off and five speeds.

Output voltages at 240V/1PH/50Hz 0, 90, 115, 140, 175, 240 volts.

Neon indicator. Enclosures are protected to IP54.

Dimensions	Stock Ref
230 x 168 x 118	<b>10314103A</b>
230 x 168 x 118	<b>10314105A</b>
284 x 240 x 132	<b>10314107A</b>

Additional ratings and three phase units are available, please enquire.

# Controllers & Sensors



## Remote Delay Timer

A remote delay timer for use with all domestic products gives the option of offering a 2 minute delay before the fan starts. Once the fan has started the overrun timer is adjustable between 5-25 minutes.

Stock Ref  
**457986**

## Surface Mounting Box

A surface mounting back box is available.

Stock Ref  
**410020**



## Isolator Relay Controller

Allows fan unit to be isolated from other mains circuit when used with trickle/boost switch or light switch control.

Stock Ref  
**442030**

## Surface Mounting Box

A surface mounting back box is available.

Stock Ref  
**410020**



## 150VA Transformer

Surface Mounting Transformer with six voltage selections for trickle settings to match dwelling volume. Provides Boost/Trickle ventilation when used with humidity sensors or a manual switch.  
95 x 225 x 75mm (H x W x D).

Stock Ref  
**563538A**



## 2-Way Switch and Neons

A double gang switch to boost from high to low speeds on all heat recovery systems, incorporating neon lights to indicate speed settings. Suitable changeover relay required.  
85 x 145 x 10mm (H x W x D).

Stock Ref  
**459746**





### Normal Boost Switch

A single gang switch to boost from high to low speeds on all heat recovery systems.  
85 x 85 x 10mm (H x W x D).

Stock Ref  
**455213**



### LED Indicator

Compatible with the Sentinel Kinetic range, the LED indicator illuminates when the MVHR unit requires a filter check or if the unit has a fault. Supplied with 15 metres of cable.  
85 x 85 x 10mm (H x W x D).

Stock Ref  
**448356**



### Normal Boost Purge Switch

A single gang switch to operate between normal, boost and purge speeds.  
85 x 85 x 10mm (H x W x D).

Stock Ref  
**5108454**



### Momentary Push Switch

Compatible with the Sentinel Kinetic range, the momentary switch boosts the unit for 30 minutes.  
85 x 85 x 10mm (H x W x D).

Stock Ref  
**448929**



### Summer Mode Switch

Suitable for Integra, HR200V and HR300RW6, the Summer Mode Switch isolates the intake fan to give an Extract-Only mode.

Stock Ref  
**409999**



### Normal/Boost Switch - Stainless Steel

A single gang switch to operate normal/boost functions on MVHR systems. Brushed stainless steel finish.  
90 x 90 x 18 (H x W x D).

Stock Ref  
**437320**



### Normal/Boost Switch with Light Indicator

A single gang switch with LED illumination when in the Boost condition.  
85 x 85 x 10mm (H x W x D).

Stock Ref  
**449060**

# Ventilation Accessories



## Fixing Plates

A single plate available in 300mm and 450mm square modular sizes for permanent fixing on walls or for use with other modular components.

Manufactured in high impact recyclable thermoplastic.

Unit Size	Stock Ref
6"	561136
7"	561137
9"	561139
12"	561142

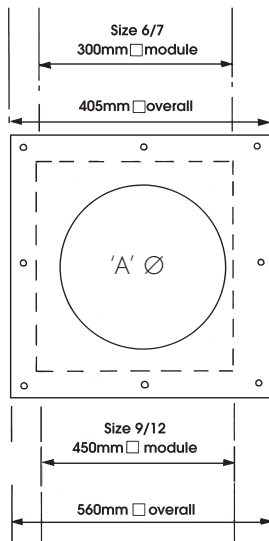

Vent-Axia fixing plate

Unit size	'A' Ø	Module Size
6"	184mm	300mm □
7"	222mm	300mm □
9"	260mm	450mm □
12"	337mm	450mm □



## T-Series Adaptor Kits

Used for T-Series Window models in secondary double glazing, Roof models in secondary double glazing in exposed areas, Roof models through roofs and Darkroom models installed through either roof or walls. Adaptor kits allow units to be installed on two surfaces.

T-Series Adaptor kits consist of two Mounting plates with weather-tight seals and a set of fixing screws.

Unit Size	Stock Ref
6"	W561031
7"	W561032
9"	W561033
12"	W561034

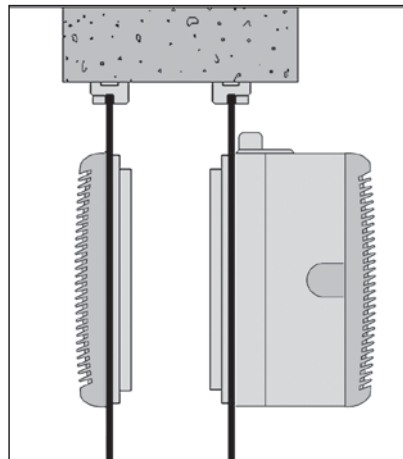

## T-Series Extended Fixing Rod Sets

For use with T-Series Window and Roof models fitted through walls. Consists of a set of rods which are cut to suit the wall thickness.

Maximum thickness of wall 370mm.

Rod thread 3.5mm.

Unit Size	Stock Ref
6", 7" & 9"	568104
12"	568106

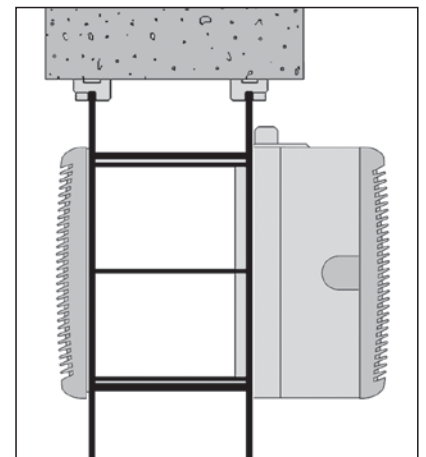



### Wall Liner Section

Designed for T-Series units installed in walls thicker than 315mm, each liner section provides a maximum extension of 150mm. Wall liner section can also form a frame for Panel models in walls.

#### T-Series Wall Liners

Unit Size	Stock Ref
6"	460094
7"	460095
9"	460096
12"	460086

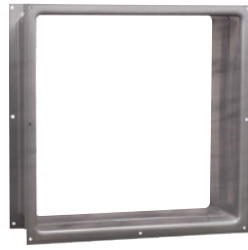

### Mounting Boxes

A flanged sleeve in 300mm and 450mm square modular sizes used as an interconnecting sleeve between other modular accessories.

Mounting boxes will accept the depth of a unit and can be mounted in conjunction with a Fixing plate and Eggcrate grille for ventilation through ceilings.

Duct length 200mm.

Unit Size	Stock Ref
6"/7"	560236
9"/12"	560239

Unit Size	Mounting box modular size
6"/7"	300mm □
9"/12"	450mm □

### Joining Bolt Set

Set of 8 nuts, bolts and washers.

Stock Ref  
563000

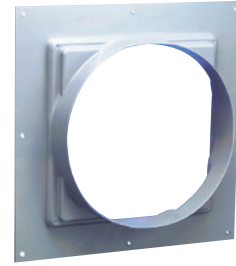

### Single Spigots

Single spigots in 300mm and 450mm square modular sizes. Used to connect Flexible ducting to Mounting boxes and other modular accessories or can be fixed directly to walls.

Manufactured in flame retardant high impact thermoplastic.

Unit Size	Nom Dia	Stock Ref
6"	175mm(B)	560637
6"/7"	225mm(B)	560639
7"	250mm(A)	560640
9"	300mm(A)	560642
9"	300mm(B)	566142
12"	400mm(B)	566146

Vent-Axia single spigot		
Unit Size	'A' Ø	Module Size
6"	B 175mm	300mm
6"	B 225mm	300mm
7"	B 225mm	300mm
7"	A 250mm	300mm
9"	A 300mm	300mm
9"	B 300mm	450mm
12"	B 400mm	450mm

# Ventilation Accessories



## Multi-Spigot Plates

Available with 2, 3, 4 or 5 circular spigots of 100mm diameter. Multi-spigot plates are used in conjunction with 100mm Flexible ducting and other modular accessories to ventilate several small areas especially internal WCs. For use with Size 6 units only. Manufactured in flame retardant high impact recyclable thermoplastic.

Available in 300mm square modular size.

Description	Stock Ref
2-3-4 Spigots	560734
5 Spigots	560735



## T-Series Direct Mount Spigots

Used to connect Flexible ducting directly to the inlet side of all T-Series models and the outlet side of T-Series Window models.

Manufactured in flame-retardant high impact recyclable thermoplastic.

Unit Size	Stock Ref
6" All models	560501
7" All models	560502
9" WW/RF	560503
9" WL/PL	560504
12" All models	560505



## T-Series Darkroom Cowl Assembly

For use with all T-Series fans for Darkroom applications. Designed to give light protection.

Can also be used in other light sensitive areas such as medical, dental and veterinarian applications.

Unit Size	Stock Ref
6"	460585
7"	460586
9"	460587
12"	460588

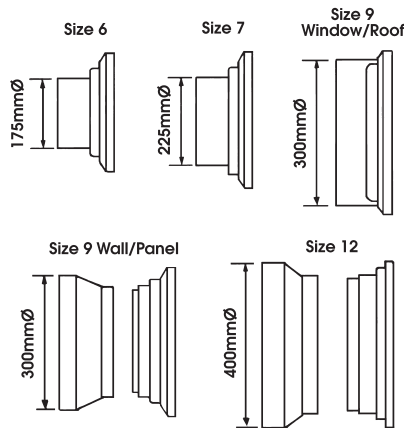

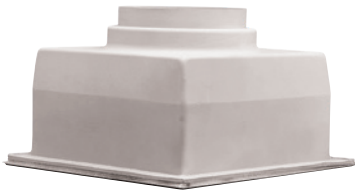

### Plenum Boxes

The Plenum box allows square grilles and diffusers to connect to circular duct. Each box size has a two diameter circular spigot for maximum versatility. The box is deep enough to accommodate both a double deflection grille and opposed blade damper.

Manufactured in flame retardant high impact recyclable thermoplastic.

Size	Stock Ref	Nom. Ø
200mm	560601	125/150mm
250mm	560602	150/175mm
300mm	560603	200/225mm
300mm	560604	250/300mm
450mm	560605	315/400mm

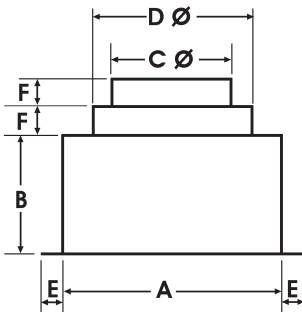

### Dimensions (mm)

Stock Ref.	A	B	C Ø	D Ø	E	F
560601	200	130	125	150	25	25
560602	250	130	150	175	25	25
560603	300	130	200	225	25	25
560604	300	130	250	300	25	25
560605	450	130	315	400	25	25



### Single Deflection Grilles

Single deflection grilles are suitable for either side wall or exposed duct applications.

The Single deflection grille has a single row of blades which permit up to 45° deflection of the air in one plane.

Satin silver finish.

Size 6/7 fits 300mm square modular size and size 9/12 fits 450mm square modular size.

Module size	Stock Ref
200mm sq	561370
250mm sq	561371
300mm sq	561372
450mm sq	561373

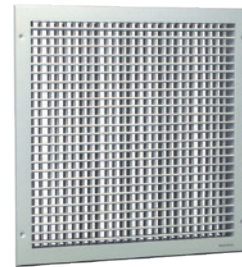

### Double Deflection Grilles

Double deflection grilles are suitable for supply air for either side wall or exposed duct applications.

The Double deflection grille has two rows of blades set at 90° apart which permit up to 45° deflection of the air in two planes.

Satin silver finish.

Size 6/7 fits 300mm square modular size and size 9/12 fits 450mm square modular size.

Module size	Stock Ref
200mm sq	561380
250mm sq	561381
300mm sq	561382
450mm sq	561383

# Ventilation Accessories



## Eggcrate Grilles

Eggcrate grilles can be used for air replacement or air extract purposes.

Used underneath Roof plate assemblies with Roof models, underneath single spigots in ceilings, underneath mounting boxes and on the inside faces of walls that have units in fixed and removable wall plates on the outside of the wall.

Comprising a 13mm square by 13mm deep mesh eggcrate core housed in a frame which has a satin silver or white finish.

Size 6/7 fits 300mm square modular size and size 9/12 fits 450mm square modular size.

Size 6/7 - 785cm<sup>2</sup> free area  
Size 9/12 - 1810cm<sup>2</sup> free area

200mm Sq - 340 cm<sup>2</sup>  
250mm Sq - 530 cm<sup>2</sup>

Satin finish.

Module size	Stock Ref
200mm sq	561303
250mm sq	561305
300mm sq	561301
450mm sq	561302

White finish.

Module size	Stock Ref
125mm sq	560846
200mm sq	560847
250mm sq	560848
300mm sq	560849
450mm sq	560850



## Opposed Blade Dampers

Opposed blade dampers are used to regulate air flow through all Vent-Axia grilles and diffusers. Key operated.

This action ensures that the downstream airflow is non-directional when the damper is in the partially closed position. Opposed blade dampers have aluminium blades and the frame is left in natural mill finish.

Can be used in conjunction with Eggcrate, Single deflection and Double deflection grilles.

Size 6/7 fits 300mm square modular size and size 9/12 fits 450mm square modular size.

Module size	Stock Ref
200mm sq	561341
250mm sq	561342
300mm sq	561343
450mm sq	561344



## Filtered Inlet Grille

For ceiling, panel or glass mounting. Consists of a size 6 grille, washable filter, adaptor kit and a stepped spigot to suit 100, 125 or 150mm diameter ducting.

Grille size: 226mm x 220mm  
Spigot depth: 100mm  
Fixing hole diameter: 184mm

Stock Ref  
W563536



## 4-Way Diffusers

Manufactured in polypropylene plastic. Four diffuser cassettes can be set for downward or 45° discharge in any of sixteen directional combinations.

Colour: Ivory

Neck Size	Stock Ref
225mm	10546230A
300mm	10546300A
350mm	10546350A



## Neck Adaptor

Used to connect Flexible ducting directly to 4-way diffusers. Integral volume control damper for duct sizes up to 300mm.

Diffuser	4-Way	
Duct Size	Neck Size	Stock Ref
150mm Ø	225mm	10547150A
200mm Ø	225mm	10547200A
250mm Ø	300mm	10547250
300mm Ø	350mm	10547300



### Window/Wall/Ceiling Termination Sets

Used to terminate Flexible ducting at windows. Can be used with the Extended fixing rod set or Fixing plates for termination at walls. Used with Flexible ducting and Worm drive clips.

Consists of a Direct mount spigot, Adaptor kit, Window grille and all screws.

Unit Size	Spigot DiaØ	Stock Ref
6"	175mm	W560151
7"	225mm	W560152
9"	300mm	W560153
12"	400mm	W560154

Other sizes	Spigot DiaØ	Stock Ref
	100/125/150mm	W10554150
	200mm	W10554200
	250mm	W10554250
	315mm	W10554315

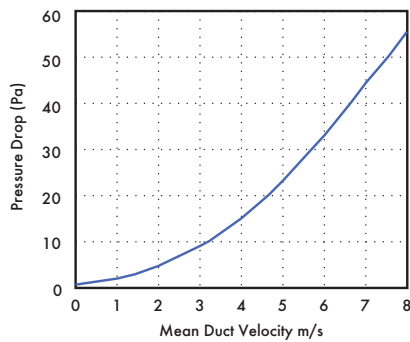

### Air Replacement Non-Vision Grilles

#### Satin finish

Non-vision grilles consist of a single row of overlapping chevron vanes. Used as transfer grilles for doors or partitions, the overlapping vanes prevent through-vision.

Module size	Stock Ref
300mm sq	561311
450mm sq	561312

#### Black finish

In addition to preventing through-vision the black finish also limits light transference. Use two grilles back to back for darkroom applications.

Module size	Stock Ref
300mm sq	561321
450mm sq	561322



### Roof Termination Sets

Used to terminate Flexible ducting at roofs. Consists of: Direct mount spigot, Adaptor kit, Roof cowl, Deflector and all screws. Can be used with Roof Plate Assemblies for installation on flat roofs.

#### T-series units

Size	Spigot Ø	Stock Ref
6"	175mm	560161
7"	225mm	560162
9"	300mm	560163
12"	400mm	560164

#### Vent-Axia roof termination

Diameter	Stock Ref
100/125/150mm	10555150
200mm	10555200
250mm	10555250
315mm	10555315

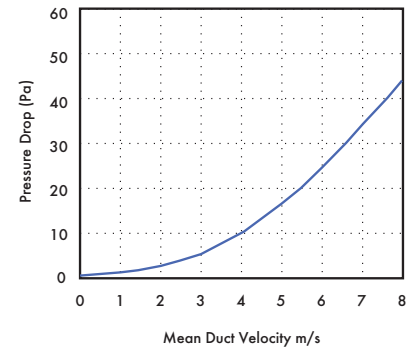



# Ventilation Accessories



## Air Replacement Non-Vision Door Grilles with Matching Flanges

Non-vision grilles consist of a single row of overlapping chevron vanes to prevent through-vision, supplied with matching flanges. The grille is fitted to one side of the door with the matching flange on the other side.

Suitable for door thicknesses of 19-49mm.

Available in Silver or Brown finish, in two sizes, 600 x 150 and 600 x 300mm.

### Satin finish

Size	Stock Ref
600 x 150mm	<b>561390</b>
600 x 300mm	<b>561391</b>

### Brown finish

Size	Stock Ref
600 x 150mm	<b>560900</b>
600 x 300mm	<b>560901</b>



## Heavy Duty T-Series Wall Grilles

Tough aluminium construction for accessible public areas. Fits T-Series wall models in place of existing external grille. Finish T-Series grey.

Size	Stock Ref
6"	<b>452725</b>
7"	<b>452726</b>
9"	<b>452727</b>
12"	<b>452728</b>



## External Louvre Mill and Brown Finish

Weather resistant external louvres are suitable for air intake or discharge and for use with ducting on external walls.

The narrow blade construction has a 38mm pitch set at 45° with a depth of 41mm and an integral rain lip.

Standard 32mm wide undrilled outer flanges in aluminium have fully welded mitre corners as standard.

Size 6/7 fits 300mm square modular size and size 9/12 fits 450mm square modular size.

Size 6/7 - 345cm<sup>2</sup> free area  
Size 9/12 - 824cm<sup>2</sup> free area

### Satin finish

Size	Stock Ref
225mm sq	<b>561350</b>
300mm sq	<b>561351</b>
400mm sq	<b>561355</b>
450mm sq	<b>561352</b>

### Brown finish

Size	Stock Ref
225mm sq	<b>560910</b>
300mm sq	<b>560911</b>
400mm sq	<b>560912</b>
450mm sq	<b>560913</b>

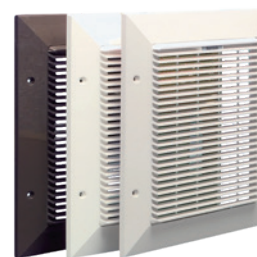

## Louvre Grilles

Louvre grilles can be used for air replacement, for extract purposes and as an external louvre. Available in four sizes, the assembly fits over rather than into the aperture making it especially useful where there are space restrictions within the duct.

Manufactured in thermoplastic. Choice of three colours: White, Brown and Grey.

Size 6	- 190cm <sup>2</sup> free area
Size 7	- 335cm <sup>2</sup> free area
Size 9	- 415cm <sup>2</sup> free area
Size 12	- 705cm <sup>2</sup> free area

### Grille Dimensions (mm)

Size	W x H
6"	= 310 x 303
7"	= 352 x 345
9"	= 391 x 388
12"	= 470 x 467

The grilles and surrounds are moulded in ABS plastic to tone in with building materials, therefore an equivalent BS or RAL colour reference cannot be given.

Unit Size	Colour	Stock Ref
6"	Grey	<b>W561431</b>
6"	Brown	<b>561411</b>
6"	White	<b>561421</b>
7"	Grey	<b>W561432</b>
7"	Brown	<b>561412</b>
7"	White	<b>561422</b>
9"	Grey	<b>W561433</b>
9"	Brown	<b>561413</b>
9"	White	<b>561423</b>
12"	Grey	<b>W561434</b>
12"	Brown	<b>561414</b>
12"	White	<b>561424</b>



### Roof Plate Assemblies

Vent-Axia roof plate assemblies are manufactured in high impact recyclable thermoplastic. They consist of a strong one piece moulded plate with extended sides to assist flashing and weather protection. A separate sub-frame is provided for permanent fixing to the roof kerb. The Vent-Axia Roof model is then fitted to the plate using a suitable sealing compound between the Cowl and plate, ensuring a weather-tight seal.

Size	Stock Ref
6"	560136
7"	560137
9"	560139
12"	560142

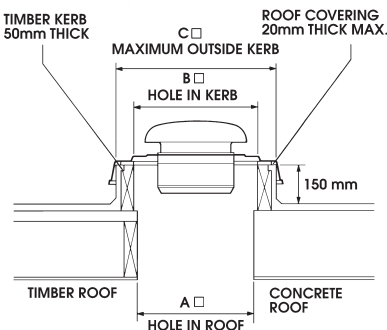

Size	A	B	C
6"	300mm	335mm	465mm
7"	300mm	335mm	465mm
9"	450mm	490mm	615mm
12"	450mm	490mm	615mm

In addition to the size 6, 7, 9 & 12 Roof Termination Sets, the Roof Plate Assemblies can also be used with the following Roof Terminations part numbers.

- 10555150 use size 6 Roof Plate Assembly
- 10555200 use size 7 Roof Plate Assembly
- 10555250 use size 9 Roof Plate Assembly
- 10555315 use size 12 Roof Plate Assembly



### Joining Pieces

Used to join lengths of flexible ducting to give a long-lasting airtight connection.

Duct Size	Stock Ref
100mm Ø	561804
125mm Ø	561805
150mm Ø	561806
175mm Ø	561807
200mm Ø	561808
225mm Ø	561809
250mm Ø	561810
300mm Ø	561812
315mm Ø	561813
400mm Ø	561816



### Worm Drive Clips

Stainless steel tightening band with quick-fix screwed ends for securing flexible ducting.

Max. Ø	Stock Ref
110mm	561704
215mm	561707
270mm	561710
380mm	561715
525mm	561720
660mm	561726



# Plate & Case Fans

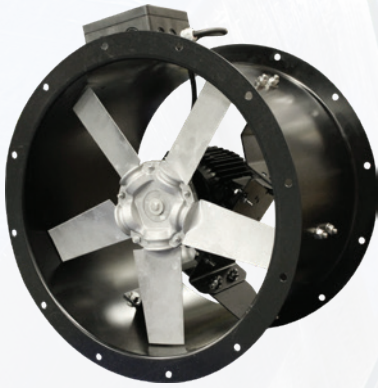

Vent-Axia Plate and Case axial fans have been developed with a detailed understanding of air movement requirements within the European market. The products are designed to meet the exacting demands of both modern building services as well as the replacement market.

The fans are supplied fully assembled and ready for installation in any application together with a comprehensive range of accessories and controllers.

Our new range of VSP and VSC fans have been designed incorporating the FE2 Owllet impeller. This state of the art impeller ensures maximum efficiency and minimum noise for the application.

The bifurcated and cased axial ranges along with the KAF range are designed for reliable operation within the aggressive environments of commercial kitchens.

**Vent-Axia**<sup>®</sup>







Sabre® Plate Mounted Sickle Fans (VSP)

J3-J8

---



Sabre® Sickle Short Case Fans (VSC)

J9-J16

---



Long Case Axial Fans (LCA)

J17-J46

---



Kitchen Axial Fans (KAF)

J47-J50

---



Bifurcated Case Axial Fans (BIFA)

J51-J76

---

# Sabre Plate Mounted Sickle Fans (VSP)

- Swept impeller with Aerofoil blades, winglets and serrated trailing edge for optimum performance
- One shot die cast impeller, dynamically balanced for smoother operation
- Operating temperature up to 70°C
- External Rotor Motors on all models for compact efficient design
- All models speed controllable
- Guards fitted as standard on all models
- Thermal Overload Protection for motor protection
- Maintenance free sealed for life bearings
- 2 Year Guarantee



The latest generation of the Vent-Axia Sabre® Plate Mounted Sickle fans incorporate the very latest FE2 Owlett impeller offering improved performance over the previous ranges with up to 7dB(A) reduction in sound and up to 15% improvement in efficiency ensuring the best available fan performance in its class. The advanced blade design, matched to a purpose designed external rotor motor ensures unrivalled reliability and controllability.

---

## Design and Development

Using a combination of NASA research into wing performance and winglets, coupled with a study of bird flight, has enabled the development of the best available Sickle blade profile. By matching this to a purpose designed close fitting mounting plate ensures best use of this blade technology thereby reducing noise and improving the performance in plate axial fans.

---

## Construction

Vent-Axia Sabre® Plate Mounted Sickle fans are based on an integrated impeller and external rotor motor design, which produces a very compact unit. Together with a specially designed bell mouth inlet and mounting plate, the complete fan is lightweight and ensures an excellent performance to sound level ratio.

The mounting plate is formed from a single sheet, protected with a tough epoxy paint finish. Inlet finger guards and motor supports are manufactured from steel rod and electro welded for extra strength. Finger guards give protection to BS 848 Part 5. Manufacture is controlled to BS EN ISO 9001:2015 Standards.

---

## Impellers

The impellers incorporate the latest in sickle blade aerofoil technology to ensure minimum sound and maximum performance. Impellers up to 400mm diameter are moulded from a composite polymer, impellers above this size are Aluminium. The motors and impellers are factory matched, statically and dynamically balanced to ISO 1940 part 1, Quality Class G.6.3.

---

## Motors

The external rotor motors are specifically designed and styled for this range of fan. Ball bearings are greased for life. Sizes 315 - 710 motors are protected to IP54 against dust and moisture, complying with BS EN 60529.

They have ribbed aluminium body castings for efficient cooling with Motor insulation to Class 'F' (from -40°C to +70°C). Speed controlled sizes 450 to 710, 6 & 8 pole motors are only suitable for operating temperatures of up to 40°C.

---

## Electrical

The Sabre® Plate Mounted Sickle fan range is available for either single phase 220-240V 50 Hz capacitor start and run or three phase 380-415V 50Hz. Motors are fitted with Thermal Overload Protection which should be wired into all controller circuits and into starter contactors to prevent motor damage due to overloading / overheating.

---

## Speed Control

Units are suitable for speed control by either electronic, voltage reduction or frequency inverters where permissible. For optimum efficiency and controllability Vent-Axia recommend the use of the eDemand Inverter controller to give close control via sensors or manual control.

---

## Form of Running

Plate mounted fans (ex-stock) are supplied for extract use (Form 'A' running).

---

## Performance

The fan performance is in accordance with tests to ISO 5801.

## Sound Levels

Fan sound levels are measured in a reverberant chamber in accordance with ISO 3744 Part 1. Published dB(A) figures are free field sound pressure levels at 3m with spherical propagation at a reference level of  $2 \times 10^{-5}$ Pa (20 micro-Pascal). The sound power level spectra figures are dB with a reference level of  $10^{-12}$  Watts (1 pico-watt).

To ensure minimum noise levels during speed control, either an auto transformer or eDemand inverter speed control is recommended.

## Accessories

A full range of accessories is available with the Sabre® Plate Mounted Sickle fans:

- Electronic speed controllers
- Auto transformer speed controllers
- eDemand inverter speed control
- D.O.L. starters
- Louvre shutter
- Discharge guard

## Fan Dimensions (mm)

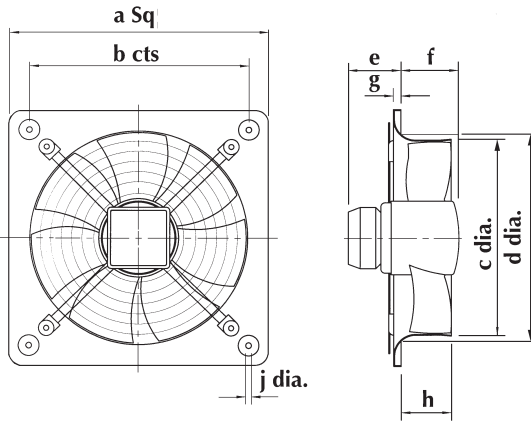

Stock Ref	kg	A	B	C	D	E	F	G	H	J
VSP25012/14	3.3	370	320	260	264.5	78	73.4	6	50	7
VSP31514/34	6.7	430	380	349	349	78	83.9	11	63	9
VSP35514/34	7.5	485	435	390	390	78	82.9	12	68	9
VSP40014/34	7.8	549	490	412	419.8	90	91.5	12	88	9
VSP45014/34/16/36	16.2	575	535	463	480	110	143.5	14	96	11
VSP50014/34/16/36	20.1	655	615	517	528	84.5	141.5	16	104	11
VSP56014	31.8	725	675	568	589	98.3	167.5	16	119	11
VSP56034/16/36	24.2	725	675	568	589	82.5	162.5	16	119	11
VSP63034/36	41.6	805	750	643	664	111	159.5	20	130	11
VSP63016	33.7	805	750	643	664	70.5	174.5	20	130	11
VSP71016/36/38	38.6	850	810	720	763	44	201.5	20	150	14.5

## Accessories Dimensions (mm)

Discharge Guard 'K' factor loss 0.25

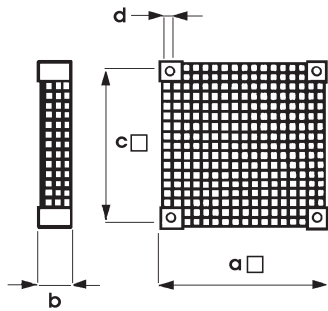

Stock Ref	a	b	c	Ød
10502325	397	64	351	8
10502375	449	64	403	8
10502450	501	64	455	8
10502525	553	64	507	8
10502630	808	150	735	8
10502800	1010	140	-	8

If a discharge guard is required with a louvre shutter the next size up discharge guard should be selected.

Louvre Shutter

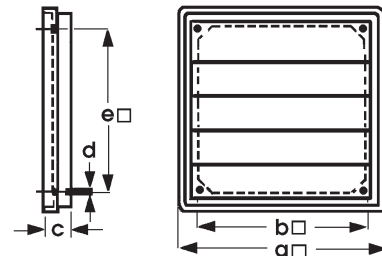

Stock Ref	a	b	c	Ød	e
LS250	294	265	25	6	230
LS315	344	276	26	6	295
LS355	398	312	26	6	329
LS400	458	365	26	6	382
LS450	499	395	31	6	432
LS500	544	444	31	6	477
LS560	605	533	31	6	533
LS630	694	627	31	6	626
LS710	790	722	43	6	722

Performance Curves

250 to 400 dia. - Pole 2 & 4

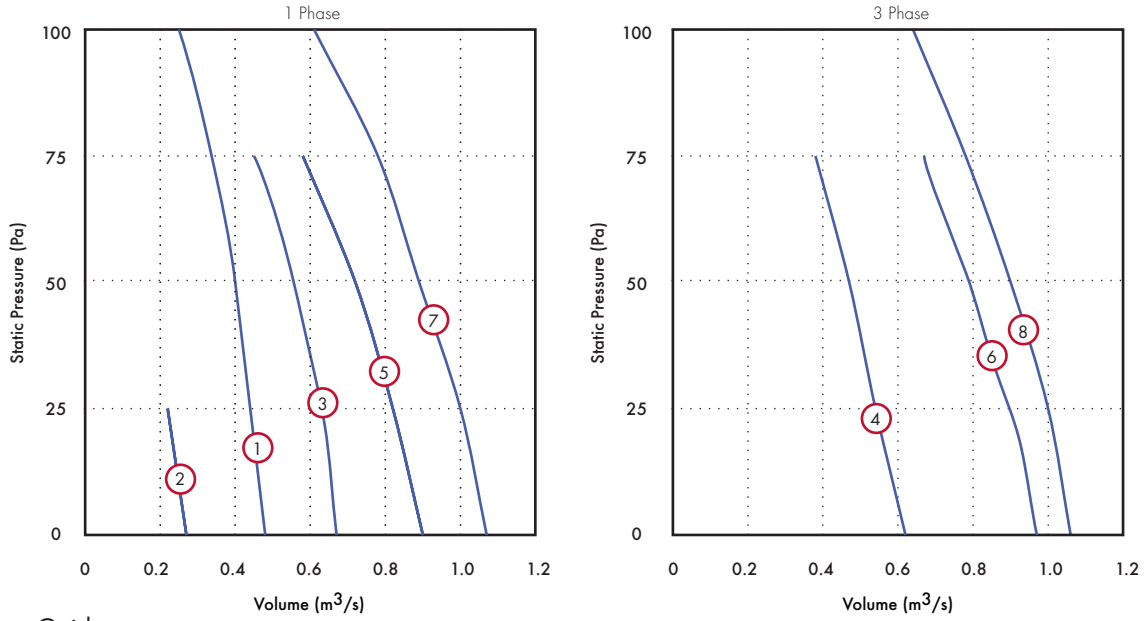

Performance Guide

Stock Ref	Supply	IP	Motor Rating	F.L.C. kW	S.C. Amps	Poles	rpm	Curve	Volume m³/s @ Pa					dB(A) @ 3m	
									0	25	50	75	100		
VSP25012	230/1/50	IP54	0.12	0.54	2.16	2	2160	1	Volume m³/s	0.48	0.44	0.40	0.36	0.25	50
									Power Watts	110	115	118	121	125	
VSP25014	230/1/50	IP54	0.05	0.24	0.96	4	1370	2	Volume m³/s	0.27	0.22				37
									Power Watts	46	48				
VSP31514	230/1/50	IP54	0.12	0.54	2.16	4	1360	3	Volume m³/s	0.67	0.63	0.51	0.45		45
									Power Watts	111	118	124	130		
VSP31534	400/3/50	IP54	0.12	0.39	1.7	4	1450	4	Volume m³/s	0.62	0.54	0.47	0.38		47
									Power Watts	105	115	117	120		
VSP35514	230/1/50	IP54	0.13	0.56	2.24	4	1260	5	Volume m³/s	0.90	0.82	0.72	0.58		46
									Power Watts	132	141	151	162		
VSP35534	400/3/50	IP54	0.19	0.4	1.6	4	1390	6	Volume m³/s	0.97	0.90	0.65	0.67		48
									Power Watts	152	168	176	178		
VSP40014	230/1/50	IP54	0.24	1.05	4.2	4	1340	7	Volume m³/s	1.07	1.00	0.89	0.78	0.61	46
									Power Watts	166	195	200	210	240	
VSP40034	400/3/50	IP54	0.23	0.46	1.6	4	1360	8	Volume m³/s	1.06	1.00	0.90	0.78	0.64	47
									Power Watts	160	170	190	205	220	

Sound Power Level Spectra dB (ref 10<sup>-12</sup> Watts)

Stock Ref	63Hz	125Hz	250Hz	500Hz	1KHz	2KHz	4KHz	8KHz	dB(A) @ 3m
VSP25012	65	70	68	66	64	66	62	55	50
VSP25014	56	63	56	54	53	53	49	41	37
VSP31514	71	70	65	60	58	59	55	47	45
VSP31534	75	71	62	60	61	62	59	51	47
VSP35514	67	70	67	64	58	60	53	45	46
VSP35534	74	66	61	63	64	63	59	53	48
VSP40014	72	73	66	62	60	59	54	48	46
VSP40034	67	67	61	60	60	59	54	48	47



Performance Curves

450 to 500 dia. - Pole 4 & 6

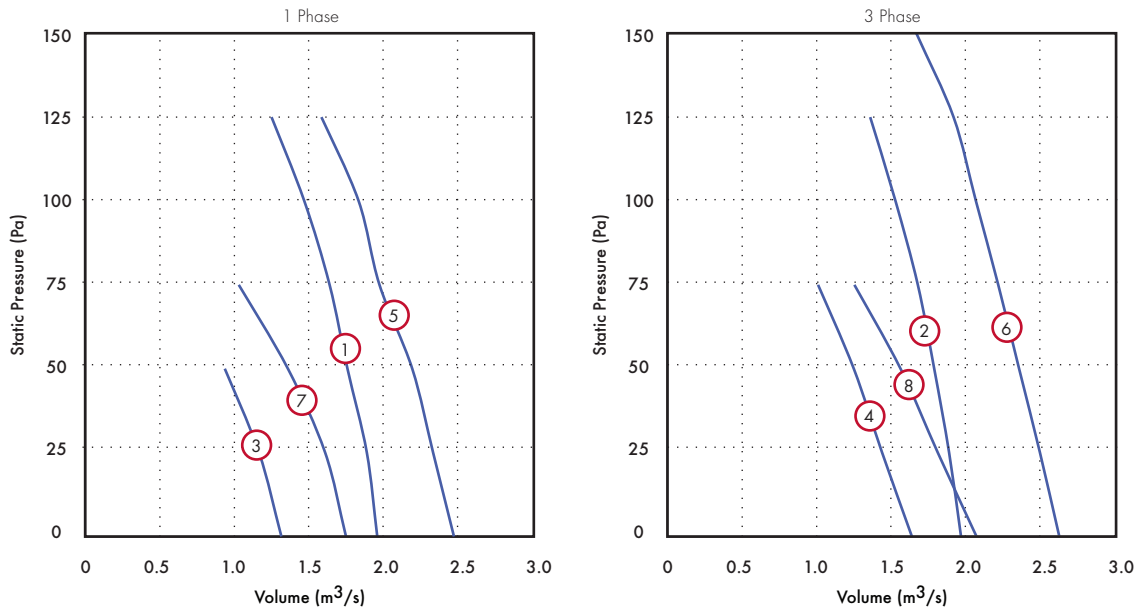

Performance Guide

Stock Ref	Supply	IP	Motor Rating kW	F.L.C Amps	S.C. Amps	Poles	rpm	Curve	Volume m³/s @ Pa						dB(A) @ 3m		
									0	25	50	75	100	125		150	
VSP45014	230/1/50	IP54	0.6	2.9	10	4	1320	1	Volume m³/s	1.96	1.89	1.76	1.64	1.47	1.25		49
									Power Watts	480	500	520	530	540	550		
VSP45034	400/3/50	IP54	0.54	1.1	4.4	4	1350	2	Volume m³/s	1.97	1.89	1.79	1.68	1.53	1.36		49
									Power Watts	440	460	480	505	520	530		
VSP45016	230/1/50	IP54	0.19	0.9	3.6	6	910	3	Volume m³/s	1.32	1.17	0.94					41
									Power Watts	165	175	180					
VSP45036	400/3/50	IP54	0.36	0.66	2.64	6	1020	4	Volume m³/s	1.64	1.44	1.25	1.01				44
									Power Watts	325	350	360	380				
VSP50014	230/1/50	IP54	0.7	3.2	12.8	4	1230	5	Volume m³/s	2.47	2.33	2.19	1.97	1.83	1.58		51
									Power Watts	630	660	670	690	720	740		
VSP50034	400/3/50	IP54	0.84	1.45	5.8	4	1340	6	Volume m³/s	2.63	2.50	2.36	2.22	2.07	1.92	1.67	52
									Power Watts	620	650	680	720	740	750	800	
VSP50016	230/1/50	IP54	0.27	1.25	5.0	6	910	7	Volume m³/s	1.75	1.61	1.36	1.03				44
									Power Watts	250	265	280	295				
VSP50036	400/3/50	IP54	0.54	0.96	3.84	6	940	8	Volume m³/s	2.07	1.81	1.56	1.25				47
									Power Watts	470	500	520	540				

Sound Power Level Spectra dB (ref 10<sup>-12</sup> Watts)

Stock Ref	63Hz	125Hz	250Hz	500Hz	1KHz	2KHz	4KHz	8KHz	dB(A) @ 3m
VSP45014	67	69	71	63	63	63	59	53	49
VSP45034	72	70	65	65	64	64	59	53	49
VSP45016	57	62	59	56	56	56	50	41	41
VSP45036	71	66	60	60	60	58	51	43	44
VSP50014	71	75	67	63	67	68	60	52	51
VSP50034	74	72	66	66	68	68	62	56	52
VSP50016	66	72	70	55	59	58	51	43	44
VSP50036	77	77	72	66	64	61	54	47	47

Performance Curves

560 to 710 dia. - Pole 4 & 6 & 8

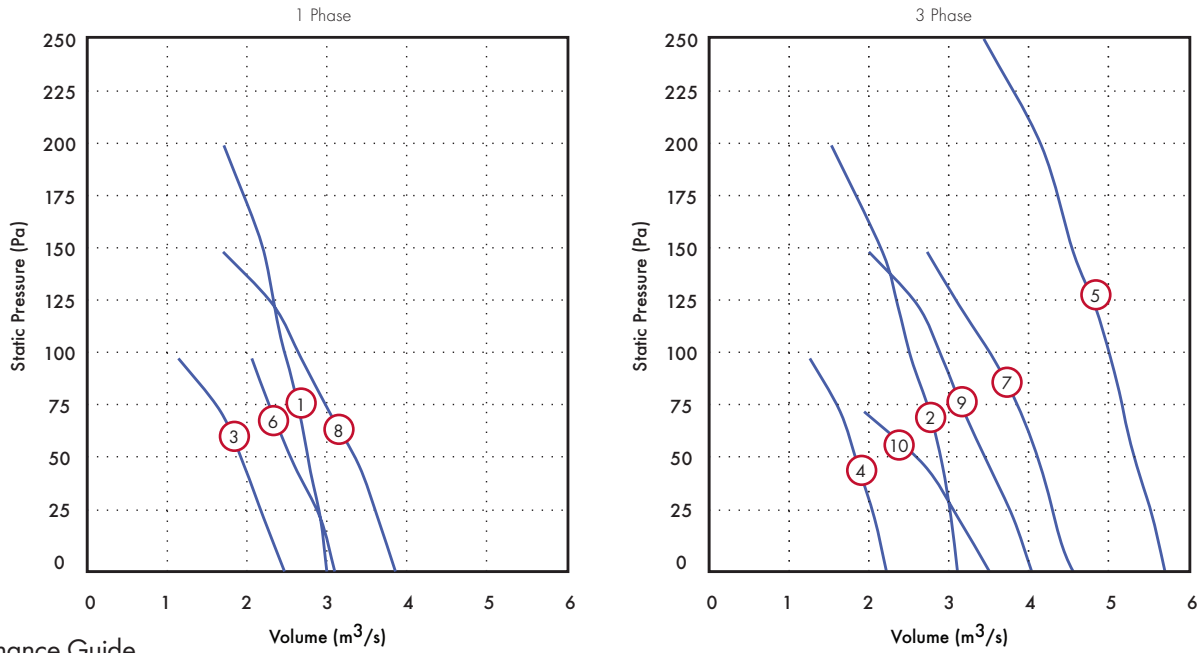

Performance Guide

Stock Ref	Supply	IP	Motor Rating	F.L.C kW	S.C. Amps	Poles	rpm	Curve	Volume m³/s @ Pa								dB(A) @ 3m		
									0	25	50	75	100	125	150	200		250	
VSP56014	230/1/50	IP54	1.15	5	20	4	1330	①	Volume m³/s	3.00	2.92	2.78	2.69	2.51	2.31	2.22	1.71		62
									Power Watts	810	830	870	890	900	980	1000	1100		
VSP56034	400/3/50	IP54	1.05	2.2	8.8	4	1280	②	Volume m³/s	3.11	3.03	2.92	2.76	2.53	2.36	2.17	1.53		57
									Power Watts	742	800	840	860	910	920	940	1044		
VSP56016	230/1/50	IP54	0.39	1.8	7.2	6	930	③	Volume m³/s	2.22	2.07	1.86	1.64	1.26					50
									Power Watts	369	394	415	438	458					
VSP56036	400/3/50	IP54	0.58	1.1	4.4	6	910	④	Volume m³/s	2.47	2.21	1.96	1.67	1.14					51
									Power Watts	489	518	542	556	576					
VSP63034	400/3/50	IP54	2.4	4.6	18.4	4	1320	⑤	Volume m³/s	5.71	5.56	5.35	5.19	5.03	4.83	4.56	4.16	3.44	62
									Power Watts	2305	2350	2400	2450	2500	2540	2587	2628	2639	
VSP63016	230/1/50	IP54	0.6	2.8	11.2	6	910	⑥	Volume m³/s	3.10	2.92	2.59	2.31	2.06					52
									Power Watts	568	603	650	679	710					
VSP63036	400/3/50	IP54	1.5	2.6	10.4	6	1040	⑦	Volume m³/s	4.56	4.32	4.07	3.81	3.56	3.13	2.73			57
									Power Watts	1538	1550	1593	1610	1645	1661	1666			
VSP71016	230/1/50	IP54	0.95	4.4	17.6	6	850	⑧	Volume m³/s	3.86	3.64	3.40	3.03	2.68	2.33	1.70			52
									Power Watts	607	666	700	760	808	850	950			
VSP71036	400/3/50	IP54	0.94	1.7	6.8	6	900	⑨	Volume m³/s	4.04	3.81	3.50	3.19	2.92	2.61	2.00			49
									Power Watts	560	620	700	768	813	861	920			
VSP71038	400/3/50	IP54	0.62	1.05	4.2	8	690	⑩	Volume m³/s	3.51	3.12	2.69	1.94						45
									Power Watts	451	510	540	616						

Sound Power Level Spectra dB (ref 10<sup>-12</sup> Watts)

Stock Ref	63Hz	125Hz	250Hz	500Hz	1KHz	2KHz	4KHz	8KHz	dB(A) @ 3m
VSP56014	79	78	74	74	77	77	73	66	62
VSP56034	84	78	76	74	75	74	70	63	57
VSP56016	75	73	66	65	67	66	60	54	50
VSP56036	77	77	67	66	67	66	60	54	51
VSP63034	85	80	77	75	78	77	71	66	62
VSP63016	74	71	73	68	68	66	60	54	52
VSP63036	84	75	71	71	74	71	65	59	57
VSP71016	81	81	72	69	70	67	61	57	52
VSP71036	69	69	68	67	68	65	59	52	49
VSP71038	66	63	63	65	62	59	50	44	45

## Accessories



Stock Ref	Supply	Electronic Controller*	5 Step Auto Transformer	eDemand Voltage*	eDemand 3ph Inverter	eDemand 1Ph Inverter	D.O.I. Starter	Overload
VSP25012A	230/1/50	SC5030TK	10314102A	444164	-	444169	444744	444698
VSP25014A	230/1/50	SC5001	10314102A	444164	-	444169	444744	444697
VSP31514B	230/1/50	SC5001	10314102A	444164	-	444169	444744	444699
VSP31534B	400/3/50	-	10314301A	444166	444172	-	444747	444699
VSP35514A	230/1/50	SC5030TK	10314102A	444164	-	444169	444744	444699
VSP35534A	400/3/50	-	10314301A	444166	444172	-	444747	444698
VSP40014A	230/1/50	SC5030TK	10314102A	444164	-	444169	444744	444700
VSP40034A	400/3/50	-	10314301A	444166	444172	-	444747	444698
VSP45014B	230/1/50	SC5060TK	10314103	444164	-	444169	444744	444702
VSP45034A*	400/3/50	-	10314302A	444166	444172	-	444747	444700
VSP45016B	230/1/50	SC5030TK	10314102A	444164	-	444169	444744	444699
VSP45036*	400/3/50	-	10314301A	444166	444172	-	444747	444699
VSP50014B	230/1/50	SC5060TK	10314105	444164	-	444169	444744	444702
VSP50034A*	400/3/50	-	10314302A	444166	444172	-	444747	444700
VSP50016B	230/1/50	SC5030TK	10314102A	444164	-	444169	444744	444700
VSP50036A*	400/3/50	-	10314302A	444166	444172	-	444747	444700
VSP56014B	230/1/50	SC5010TK	10314113A	444164	-	444170	444744	444703
VSP56034A*	400/3/50	-	10314304A	444166	444172	-	444747	444702
VSP56016B	230/1/50	SC5030TK	10314103	444164	-	444169	444744	444702
VSP56036B*	400/3/50	-	10314302A	444166	444172	-	444747	444700
VSP63034B*	400/3/50	-	10314307A	444166	444173	-	444747	444703
VSP63016B	230/1/50	SC5060TK	10314105	444164	-	444169	444744	444702
VSP63036B*	400/3/50	-	10314304A	444166	444173	-	444747	444702
VSP71016A	230/1/50	SC5060TK	10314105	444164	-	444170	444744	444703
VSP71036A*	400/3/50	-	10314302A	444166	444172	-	444747	444701

\* Electronic Voltage controllers may cause motor noise and vibration at lower speeds, transformer or Inverter recommended for noise sensitive applications

# All models are supplied with 2 speed delta/star connection motors as standard (Sizes 450 to 630 are 4/6 Pole, size 710 is 6/8 pole)

Guards: Some installations may occur where additional safety parts are needed, to ensure safety in operation. For example, the unit may be fitted at the inlet or outlet end of a ducted ventilation system, thereby exposing the impeller/motor to unguarded access. In this event, the installer must fit a safety guard complying to current regulations. These guards are available as an optional extra

Where inverters are utilised these must include Sine filters, as included within our eDemand range of inverters

Fan Dia.	Louvre shutter Stock Ref
250	LS250
315	LS315
355	LS355
400	LS400
450	LS450
500	LS500
560	LS560
630	LS630
710	LS710

Fan Dia.	Discharge guard Stock Ref
250	10502325
315	10502325
355	10502375
400	10502450
450	10502525
500	10502525
560	10502630
630	10502630
710	10502800

NOTE: If a discharge guard is required with a louvre shutter the next size up discharge guard should be selected

# Sabre Sickle Short Case Fans (VSC)

- Swept impeller with Aerofoil blades, winglets and serrated trailing edge for optimum performance
- One shot die cast impeller, dynamically balanced for smoother operation
- Operating temperature up to 70°C
- External Rotor Motors on all models for compact efficient design
- All models speed controllable
- Guards fitted as standard on all models
- Thermal Overload Protection for motor protection
- Maintenance free sealed for life bearings
- 2 Year Guarantee



The latest generation of the Vent-Axia Sabre® Sickle Short Case fans incorporate the very latest FE2 Owllet impeller offering improved performance over the previous ranges with up to 7dB(A) reduction in sound and up to 15% improvement in efficiency ensuring the best available fan performance in its class. The advanced blade design is matched to a purpose designed external rotor motor to ensure unrivalled reliability and controllability.

---

## Design and Development

Using a combination of NASA research into wing performance and winglets, coupled with a study of bird flight has enabled the development of the best available Sickle blade profile. Matching this to a purpose designed close fitting casing ensures best use of this blade technology thereby reducing noise and improving the performance in cased axial fans.

---

## Construction

The Sabre® Sickle Short Case fan range share the same case lengths as the Euroseries Cased axial range making them fully interchangeable and compatible with the full range of Vent-Axia Accessories. The strong and compact short case is constructed from rolled steel plate and protected with a tough, epoxy paint finish. Casing dimensions are to DIN 24151 and flange dimensions are to ISO 6580.

Manufacture is controlled to BS EN ISO 9001:2015. The compact motor/impeller unit is robustly supported within the casing by electro welded and epoxy coated steel rod mounting supports for ease of installation and service access. Suitable for all outdoor weather environments.

---

## Impellers

The impellers incorporate the latest in Sickle blade aerofoil technology to ensure minimum sound and maximum performance. Impellers up to 400mm diameter are moulded from a composite polymer, impellers above this size are Aluminium. The motors and impellers are factory matched, statically and dynamically balanced to ISO 1940 part 1, Quality Class G.6.3.

---

## Motors

The external rotor motors are specifically designed and styled for this range of fan. Ball bearings are greased for life. Sizes 315 - 710 motors are protected to IP54 against dust and moisture, complying with BS EN 60529.

They have ribbed aluminium body castings for efficient cooling with Motor insulation to Class 'F' (from -40°C to + 70°C). Speed controlled sizes 450 to 710, 6 & 8 pole motors are only suitable for operating temperatures of up to 40°C.

---

## Electrical

The Sabre® Sickle Short Case fan range is available for either single phase 220-240V 50 Hz capacitor start and run or three phase 380-415V 50Hz. Motors are fitted with Thermal Overload Protection which should be wired into all controller circuits and into starter contactors to prevent motor damage due to overloading / overheating.

---

## Speed Control

Units are suitable for speed control by either electronic, voltage reduction or frequency inverters where permissible. For optimum efficiency and controllability Vent-Axia recommend the use of the eDemand Inverter Controller to give close control via sensors or manual control.

---

## Form of Running

Cased mounted fans (ex-stock) are supplied for extract use (Form 'B' running).

---

## Performance

The fan performance is in accordance with tests to ISO 5801.

---

## Sound Levels

Fan sound levels are measured in a reverberant chamber in accordance with ISO 3744 Part 1. Published dB(A) figures are free field sound pressure levels at 3m with spherical propagation at a reference level of  $2 \times 10^{-5}$ Pa (20 micro-Pascal). The sound power level spectra figures are dB with a reference level of  $10^{-12}$  Watts (1 pico-watt).

To ensure minimum noise levels during speed control, either an auto transformer or eDemand inverter speed control is recommended.

## Accessories

A full range of accessories is available with the Sabre® Sickle Short Case fans:

- Electronic Speed Controllers
- Auto Transformer Speed Controllers
- eDemand Inverter Speed Control
- D.O.L. Starters
- Ancillary Packs
- Attenuators

## Fan Dimensions (mm)

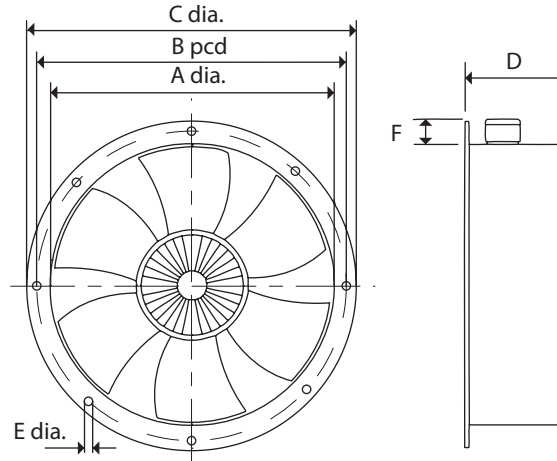

Stock Ref	Kg	A	B	C	D	E	n*	F
VSC31514	7	316	356	382	136.5	9.5	8	65
VSC31534	7	316	356	382	136.5	9.5	8	65
VSC35514	7	356	395	421	136.5	9.5	8	65
VSC35534	7.1	359	395	421	135	9.5	8	65
VSC40014	8.3	400	438	466	155	9.5	12	65
VSC40034	8.3	400	438	466	155	9.5	12	65
VSC45014	15.7	451	487	515	160	9.5	12	65
VSC45034	14.2	451	487	515	160	9.5	12	65
VSC45036	14.2	451	487	515	160	9.5	12	65
VSC50014	16.8	503	541	567	166	9.5	12	65
VSC50034	16.8	503	541	567	166	9.5	12	65
VSC50036	16.8	503	541	567	166	9.5	12	65
VSC56014	29.7	559	605	635	210	11.5	16	75
VSC56034	21.3	559	605	635	210	11.5	16	75
VSC56034	21.3	559	605	635	210	11.5	16	75
VSC63034	35.8	634	674	707	225.5	11.5	16	75
VSC63036	35.8	634	674	707	225.5	11.5	16	75
VSC71036	41.8	711	751	785	260	11.5	16	75
VSC71016	36.8	711	751	785	260	11.5	16	75
VSC71038	41.8	711	751	785	260	11.5	16	75

\*n = number of holes

# Performance Curves

315 to 400 dia. - Pole 4

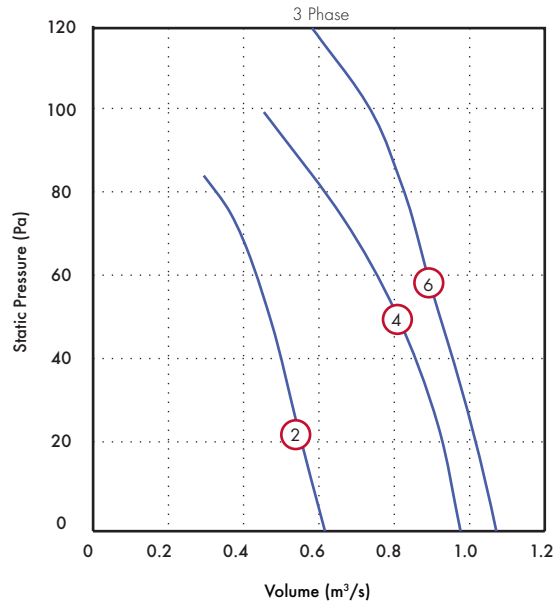
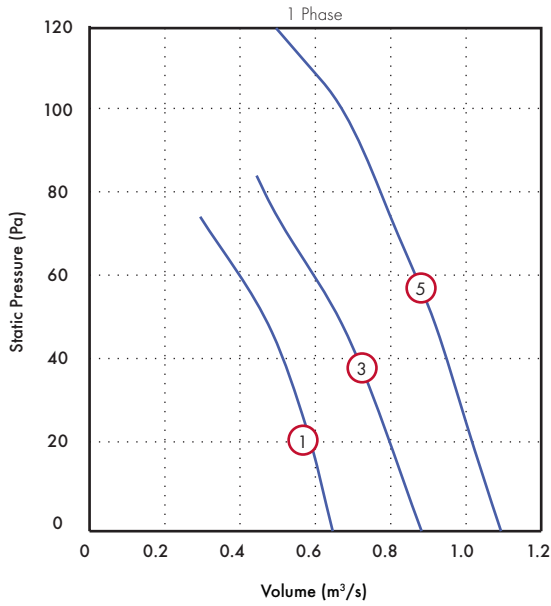

## Performance Guide

Stock Ref	Supply	IP	Motor Rating kW	F.L.C Amps	S.C. Amps	Poles	rpm	Curve	Volume m <sup>3</sup> /s @ Pa					dB(A) @ 3.0m	
									0	25	50	75	100		
VSC31514	230/1/50	IP54	0.12	0.54	11.2	4	1360	1	Volume m <sup>3</sup> /s	0.65	0.58	0.47	0.29		44
									Power Watts	85	93	100	110		
VSC31534	400/3/50	IP54	0.12	0.39	1.56	4	1450	2	Volume m <sup>3</sup> /s	0.62	0.54	0.47	0.38		47
									Power Watts	105	115	117	120		
VSC35514	230/1/50	IP54	0.13	0.56	2.24	4	1260	3	Volume m <sup>3</sup> /s	0.88	0.78	0.67	0.50		48
									Power Watts	145	155	167	181		
VSC35534	400/3/50	IP54	0.19	0.4	1.6	4	1390	4	Volume m <sup>3</sup> /s	0.98	0.92	0.82	0.67	0.44	48
									Power Watts	155	166	174	179	186	
VSC40014	230/1/50	IP54	0.24	1.05	4.2	4	1340	5	Volume m <sup>3</sup> /s	1.09	1.00	0.92	0.79	0.67	46
									Power Watts	183	197	210	224	236	
VSC40034	400/3/50	IP54	0.23	0.46	1.84	4	1360	6	Volume m <sup>3</sup> /s	1.07	1.01	0.92	0.85	0.74	44
									Power Watts	168	184	200	214	228	

## Sound Power Level Spectra dB (ref 10<sup>-12</sup> Watts)

Stock Ref	63Hz	125Hz	250Hz	500Hz	1KHz	2KHz	4KHz	8KHz	dB(A) @ 3.0m
VSC31514	71	70	65	60	58	59	55	47	44
VSC31534	75	71	62	60	61	62	59	51	47
VSC35514	67	70	67	64	58	60	53	45	48
VSC35534	74	66	61	63	64	63	59	53	48
VSC40014	72	73	66	62	60	59	54	48	46
VSC40034	67	67	61	60	60	59	54	48	44

# Performance Curves

450 to 500 dia. - Pole 4 & 6

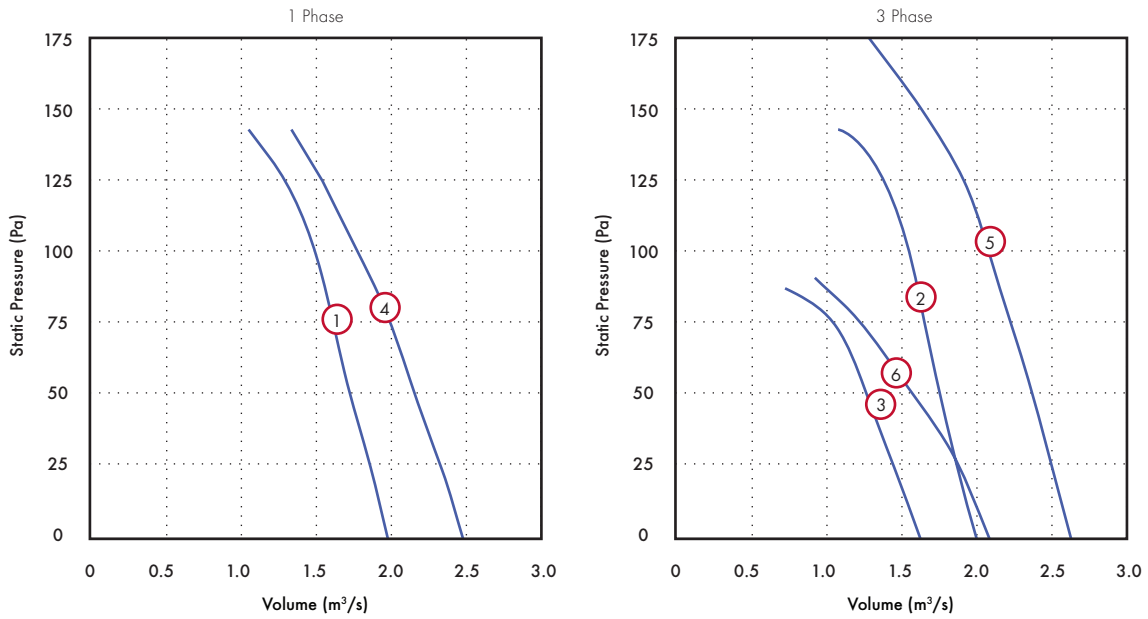

## Performance Guide

Stock Ref	Supply	IP Rating	Motor kW	F.L.C Amps	S.C. Amps	Poles	rpm	Curve	Volume m³/s @ Pa								dB(A) @ 3.0m		
									0	25	50	75	100	125	150	175			
VSC45014	230/1/50	IP54	0.6	2.9	11.6	4	1320	①	Volume m³/s	1.98	1.86	1.72	1.58	1.50	1.31				49
									Power Watts	481	490	510	530	537	546				
VSC45034	400/3/50	IP54	0.54	1.1	4.4	4	1350	②	Volume m³/s	2.00	1.89	1.75	1.68	1.53	1.41				49
									Power Watts	446	450	485	510	523	532				
VSC45036	400/3/50	IP54	0.36	0.66	2.64	6	1020	③	Volume m³/s	1.623	1.448	1.254	1.056						44
									Power Watts	333	351	364	372						
VSC50014	230/1/50	IP54	0.72	3.2	12.8	4	1230	④	Volume m³/s	2.48	2.33	2.14	2.02	1.78	1.54				51
									Power Watts	626	649	670	696	710	740				
VSC50034	400/3/50	IP54	0.84	1.45	5.8	4	1340	⑤	Volume m³/s	2.63	2.50	2.38	2.22	2.08	1.91	1.63	1.28		52
									Power Watts	616	653	683	713	739	765	802	829		
VSC50036	400/3/50	IP54	0.54	0.96	3.84	6	940	⑥	Volume m³/s	2.08	1.89	1.57	1.25						47
									Power Watts	472	498	517	530						

## Sound Power Level Spectra dB (ref 10<sup>-12</sup> Watts)

Stock Ref	63Hz	125Hz	250Hz	500Hz	1KHz	2KHz	4KHz	8KHz	dB(A) @ 3.0m
VSC45014	67	69	71	63	63	63	59	53	49
VSC45034	72	70	65	65	64	64	59	53	49
VSC45036	71	66	60	60	60	58	51	43	44
VSC50014	71	75	67	63	67	68	60	52	51
VSC50034	74	72	66	66	68	68	62	56	52
VSC50036	77	77	72	66	64	61	54	47	47



## Performance Curves

560 to 630 dia. - Pole 4 & 6

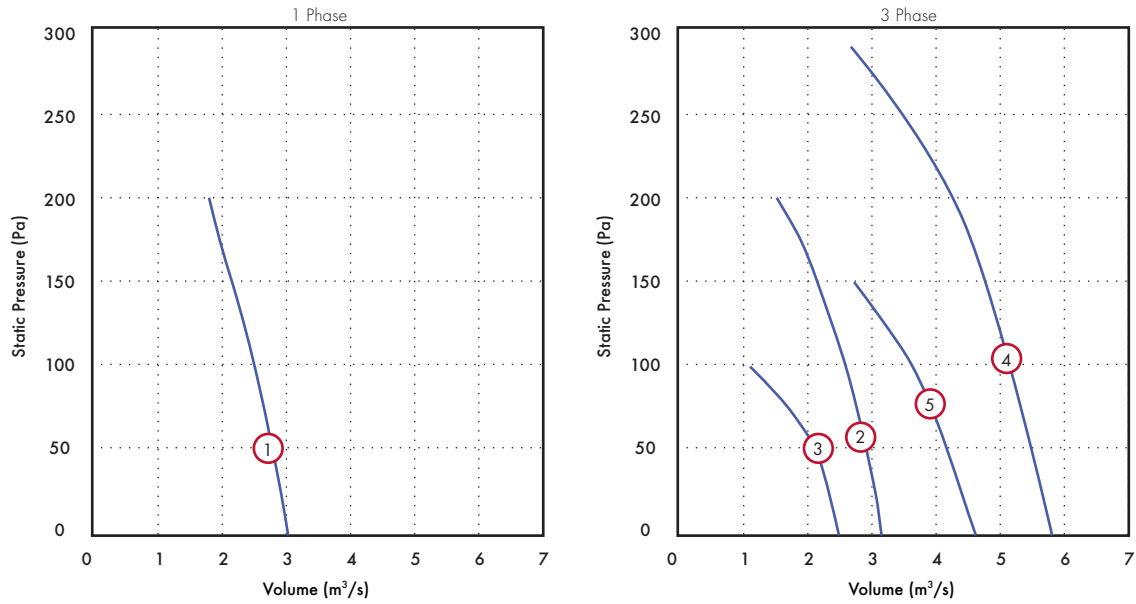

## Performance Guide

Stock Ref	Supply	IP	Motor Rating kW	F.L.C. Amps	S.C. Amps	Poles	rpm	Curve	Volume m³/s @ Pa										dB(A) @ 3.0m					
									0	25	50	75	100	125	150	175	200	225		250	275			
VSC56014	230/1/50	IP54	1.15	5	20	4	1330	①	Volume m³/s	3.03	2.92	2.78	2.67	2.50	2.36	2.15	1.96	1.79					62	
									Power Watts	824	850	910	946	996	1020	1055	1085	1114						
VSC56034	400/3/50	IP54	1.05	2.2	8.8	4	1280	②	Volume m³/s	3.15	3.06	2.89	2.76	2.59	2.39	2.14	1.89	1.52					57	
									Power Watts	742	770	830	870	910	945	975	1014	1044						
VSC56036	400/3/50	IP54	0.58	1.1	4.4	6	880	③	Volume m³/s	2.47	2.28	2.06	1.67	1.11								51		
									Power Watts	560	580	605	628	650										
VSC63034	400/3/50	IP54	2.4	4.6	18.4	4	1320	④	Volume m³/s	5.81	5.64	5.50	5.35	5.21	5.00	4.69	4.54	4.23	3.61	3.56	3.40			60
									Power Watts	2396	2440	2511	2550	2603	2650	2700	2735	2750	2762	2769	2759			
VSC63036	400/3/50	IP54	1.5	2.6	10.4	6	1040	⑤	Volume m³/s	4.62	4.39	4.17	3.91	3.63	3.21	2.72								55
									Power Watts	1608	1640	1677	1695	1722	1741	1753								

## Sound Power Level Spectra dB (ref 10<sup>-12</sup> Watts)

Stock Ref	63Hz	125Hz	250Hz	500Hz	1KHz	2KHz	4KHz	8KHz	dB(A) @ 3.0m
VSC56014	79	78	74	74	77	77	73	66	62
VSC56034	84	78	76	74	75	74	70	63	57
VSC56036	77	77	67	66	67	66	60	54	51
VSC63034	85	80	77	75	78	77	71	66	60
VSC63036	84	75	71	71	74	71	65	59	55

## Performance Curves

710 dia. - Pole 6 & 8

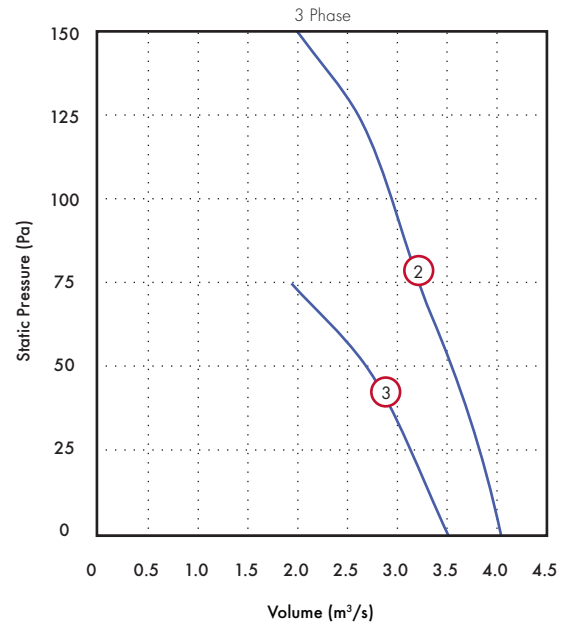
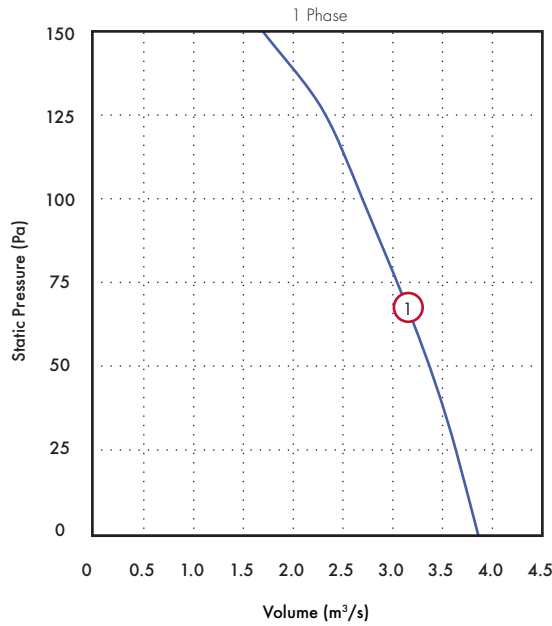

## Performance Guide

Stock Ref	Supply	IP	Motor Rating kW	F.L.C. Amps	S.C. Amps	Poles	rpm	Curve	Volume m <sup>3</sup> /s @ Pa						dB(A) @ 3.0m		
									0	25	50	75	100	125		150	
VSC71016	230/1/50	IP54	0.95	4.4	17.6	6	850	1	Volume m <sup>3</sup> /s	3.859	3.637	3.399	3.056	2.677	2.333	1.695	52
									Power Watts	607	666	705	750	808	850	950	
VSC71036	400/3/50	IP54	0.94	1.7	6.8	6	900	2	Volume m <sup>3</sup> /s	4.042	3.861	3.611	3.194	2.919	2.608	1.994	49
									Power Watts	560	590	670	768	813	861	931	
VSC71038	400/3/50	IP54	0.62	1.05	4.2	8	690	3	Volume m <sup>3</sup> /s	3.512	3.115	2.694	1.936				45
									Power Watts	451	510	560	615				

## Sound Power Level Spectra dB (ref 10<sup>-12</sup> Watts)

Stock Ref	63Hz	125Hz	250Hz	500Hz	1KHz	2KHz	4KHz	8KHz	dB(A) @ 3.0m
VSC71016	81	81	72	69	70	67	61	57	52
VSC71036	69	69	68	67	68	65	59	52	49
VSC71038	66	63	63	65	62	59	50	44	45

## Accessories Dimensions (mm)

### Mounting Feet (Pack of 2)

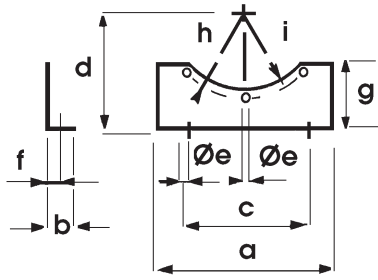

Stock Ref	a	b	c	d	Øe	f	g	h	i
MFZ315	315	40	265	200	10	20	71	178	166
MFZ355	350	40	300	225	10	20	81.5	197.5	186
MFZ400	250	40	220	250	10	20	78	219	205
MFZ450	275	40	240	275	10	20	82	243.5	230
MFZ500	315	50	280	315	1	25	100	270.5	255
MFZ560	355	50	320	355	12	25	97	302.5	285
MFZ630	400	50	360	400	12	25	108.5	337	320
MFZ710	465	50	415	450	12	25	118.5	375.5	362

### Inlet Wire Guard 'K' factor loss 0.25

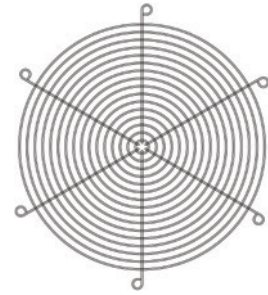

Stock Ref	Dia
WGZ315	375
WGZ355	414
WGZ400	461
WGZ450	506
WGZ500	560
WGZ560	626.5
WGZ630	695.5
WGZ710	772.5

For more information on the 'K' factor, refer to General Information Section

### Anti-Vibration Mounts (Pack of 4) - All Models

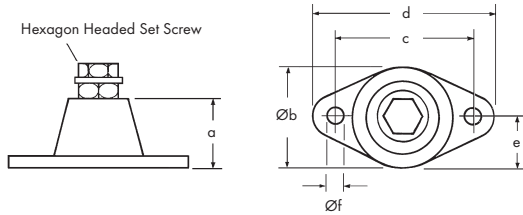

Stock Ref	a	Øb	c	d	e	Øf	n	load kg
68MP033G	27	37	54	67	18.5	7	M8	23

### Coupling Flange

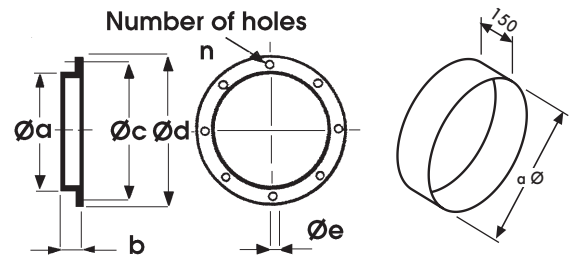

Stock Ref	Øa	b	Øc	Ød	Øe	Øf	n
CFZ315	313	40	356	382	10	319	8
CFZ355	353	40	395	421	10	359	8
CFZ400	398	45	438	466	10	404	12
CFZ450	448	45	487	515	10	454	12
CFZ500	498	45	541	567	10	504	12
CFZ560	558	45	605	635	12	564	16
CFZ630	628	45	674	707	12	634	16
CFZ710	708	50	751	785	12	714	16

## Accessories



Stock Ref	Supply	Electronic Controller*	5 Step Auto Transformer	eDemand Voltage*	eDemand 3ph Inverter	eDemand 1Ph Inverter	D.O.L Starter	Overload
VSC31514B	230/1/50	SC5001	10314102A	444164	-	444169	444744	444699
VSC31534A	400/3/50	-	10314301A	444166	444172	-	444747	444699
VSC35514B	230/1/50	SC5030TK	10314102A	444164	-	444169	444744	444699
VSC35534A	400/3/50	-	10314301A	444166	444172	-	444747	444698
VSC40014A	230/1/50	SC5030TK	10314102A	444164	-	444169	444744	444700
VSC40034A	400/3/50	-	10314301A	444166	-	-	444747	444698
VSC45014B	230/1/50	SC5060TK	10314103	444164	-	444169	444744	444702
VSC45034A*	400/3/50	-	10314302A	444166	444172	-	444747	444700
VSC45036*	400/3/50	-	10314301A	444166	444172	-	444747	444699
VSC50014B	230/1/50	SC5060TK	10314105	444164	-	444169	444744	444702
VSC50034A*	400/3/50	-	10314302A	444166	444172	-	444747	444700
VSC50036*	400/3/50	-	10314301A	444166	444172	-	444747	444700
VSC56014B	230/1/50	SC5010TK	10314113A	444164	-	444170	444744	444703
VSC56034A	400/3/50	-	10314304A	444166	444173	-	444747	444701
VSC63034B*	400/3/50	-	10314307A	444166	444173	-	444747	444703
VSC63036B*	400/3/50	-	10314304A	444166	444173	-	444747	444702
VSC71036A*	400/3/50	-	10314302A	444166	444172	-	444747	444701
VSC71016A	230/1/50	SC5060TK	10314105	444164	-	444170	444744	444703

\* Electronic Voltage controllers may cause motor noise and vibration at lower speeds, transformer or Inverter recommended for noise sensitive applications

# All models are supplied with 2 speed delta/star connection motors, as standard. (Sizes 450 to 630 are 4/6 Pole)

Guards: Some installations may occur where additional safety parts are needed, to ensure safety in operation. For example, the unit may be fitted at the inlet or outlet end of a ducted ventilation system, thereby exposing the impeller/motor to unguarded access. In this event, the installer must fit a safety guard complying to current regulations. These guards are available as an optional extra.

Where inverters are utilised these must include Sine filters, as included within our eDemand range of inverters.

Fan Dia	Mounting Feet Wire (pack of 2) Stock Ref	Inlet Wire Guard Stock Ref	Coupling Flange Stock Ref	Axial Ancillary Pack Stock Ref	Cased Axial Attenuator Stock Ref	Cased Axial Attenuator Pod 1 D Stock Ref	Cased Axial Pod 2D Stock Ref
315	MFZ315	WGZ315	CFZ315	APZ315	ACZ3151D	ACZ3151DP	ACZ3152DP
355	MFZ355	WGZ355	CFZ355	APZ355	ACZ3551D	ACZ3551DP	ACZ3552DP
400	MFZ400	WGZ400	CFZ400	APZ400	ACZ4001D	ACZ4001DP	ACZ4002DP
450	MFZ450	WGZ450	CFZ450	APZ450	ACZ4501D	ACZ4501DP	ACZ4502DP
500	MFZ500	WGZ500	CFZ500	APZ500	ACZ5001D	ACZ5001DP	ACZ5002DP
560	MFZ560	WGZ560	CFZ560	APZ560	ACZ5601D	ACZ5601DP	ACZ5602DP
630	MFZ630	WGZ630	CFZ630	APZ630	ACZ6301D	ACZ6301DP	ACZ6302DP
710	MFZ710	WGZ710	CFZ710	APZ710	ACZ7101D	ACZ7101DP	ACZ7102DP

# Long Case Axial Fans (LCA)

- Motors protected to IP55
- Motor insulation Class 'F'
- Maximum ambient temp. 54 °C
- Speed controllable via transformer or inverter
- IP55 terminal box
- Adjustable factory set polypropylene impeller
- Suitable for relative humidity levels up to 95% RH
- Manufactured to BS EN ISO 9001:2015
- Performance tested to BS 848 parts 1, 2 and ISO 5801
- 2 Year Guarantee



The Long Case Axial range of fans incorporates manually adjustable pitch impellers which provide a comprehensive range of duties offering high performance and pressure characteristics.

Available in thirteen sizes ranging from 250 to 1250mm diameter and performances from 0.24m<sup>3</sup>/s to 36m<sup>3</sup>/s with pressure development up to 1500Pa. The casing is constructed from rolled steel plate complete with flanges and protected with a tough, galvanised finish.

The Long Case Axial Fan range has a number of accessories available which include: Axial Ancillary Pack, Attenuators, Mounting Feet, Wire Inlet Guard, Coupling Flange and Speed Controllers.

---

## Sound Levels

All measurements of the sound that the fans generate have been taken strictly in accordance with BS 848 part 2, test method 1. Published sound power level spectra figures are dBW with a reference of 10<sup>-12</sup> Watts (1 Pico watt).

---

## Motors

The motors are specially selected for optimum performance and efficiency. Ball bearings are greased for life and allow the fan to be installed at any angle. Suitable for continuous operation in relative humidity up to 95% Motors are protected to IP55 against dust and water jets complying with BS EN 60529. They have ribbed aluminium body castings for efficient cooling. Motor insulation is Class 'F' (from -35 °C to +54 °C). Star/delta starting is recommended for motor output above 7.5kW.

---

## Axial Impellers

Polypropylene impeller blades are clamped in a split cast aluminium hub, with a keyway mild steel insert enabling positive locking of the impeller assembly to the motor shaft, this also allows manual adjustment of the pitch angle giving a wide selection of performance details.

---

---

## Terminal Box

Rated to IP55, protected against dust and water jets from any angle, allowing outside applications.

---

## Declaration of Conformity

All models are supplied with an EC Declaration of Conformity as defined by the EC Council Directive on Machinery 98/37/EC. This declares that all the models, on the basis of their design and construction in the form brought onto the market by Vent-Axia, are in accordance with the Machinery Directive.

---

## Electrical

Single phase 220-240V 50 Hz permanent capacitor. Three phase 380-415V 50Hz. Protection of the motor must be provided by an overload current sensing device (eg. D.O.L Starter or Star/Delta starter where appropriate) or the guarantee will be invalidated. All models are available with 4 pole motors for 250 up to 1250mm diameter with additional 2 pole motors available from 250 up to 630mm diameter.

All units are manufactured to order with 10 working days delivery (uk mainland).

## Fan Dimensions (mm)

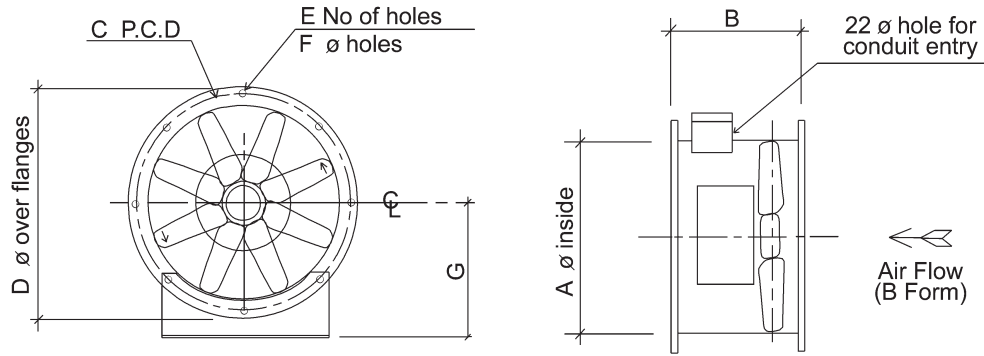

Model No.	Pole	Phase	Pitch Angle	A	B	C	D	E	F	G	Max Weight kg
LCA25	2 & 4	1 & 3	25-40	250	300	295	335	8	10	200	15
LCA31	2 & 4	1 & 3	10-38	315	420	355	385	8	10	224	23
LCA35	2 & 4	1 & 3	10-38	355	420	395	425	8	10	250	25
LCA40	2 & 4	1 & 3	10-38	400	435	450	480	8	12	280	38
LCA45	2 & 4	1 & 3	10-40	450	435	500	530	8	12	315	49
LCA50	2	3	10-31	500	565	560	590	12	12	315	86
LCA50	2	3	32-40	500	565	560	590	12	12	315	86
LCA50	4	1 & 3	10-40	500	565	560	590	12	12	315	86
LCA56	2	3	10-15	560	565	620	650	12	12	355	94
LCA56	2	3	16-24	560	565	620	650	12	12	355	94
LCA56	4	1 & 3	10-40	560	565	620	650	12	12	355	94
LCA63	2	3	10-22	630	565	690	720	12	12	400	96
LCA63	4	1	10-26	630	565	690	720	12	12	400	96
LCA63	4	3	10-40	630	565	690	720	12	12	400	96
LCA71	4	3	10-36	710	565	770	800	16	12	435	92
LCA80	4	3	10-20	800	565	860	890	16	12	480	131
LCA80	4	3	21-34	800	565	860	890	16	12	480	131
LCA90	4	3	10-26	900	565	970	1038	16	14	535	214
LCA90	4	3	28-40	900	700	970	1038	16	14	535	214
LCA100	4	3	10-22	1000	565	1070	1138	16	14	555	274
LCA100	4	3	24-32	1000	700	1070	1138	16	14	555	274
LCA100	4	3	34-40	1000	790	1070	1138	16	14	555	274
LCA125	4	3	20-34	1250	950	1320	1390	20	15	868	903

### Performance Curves

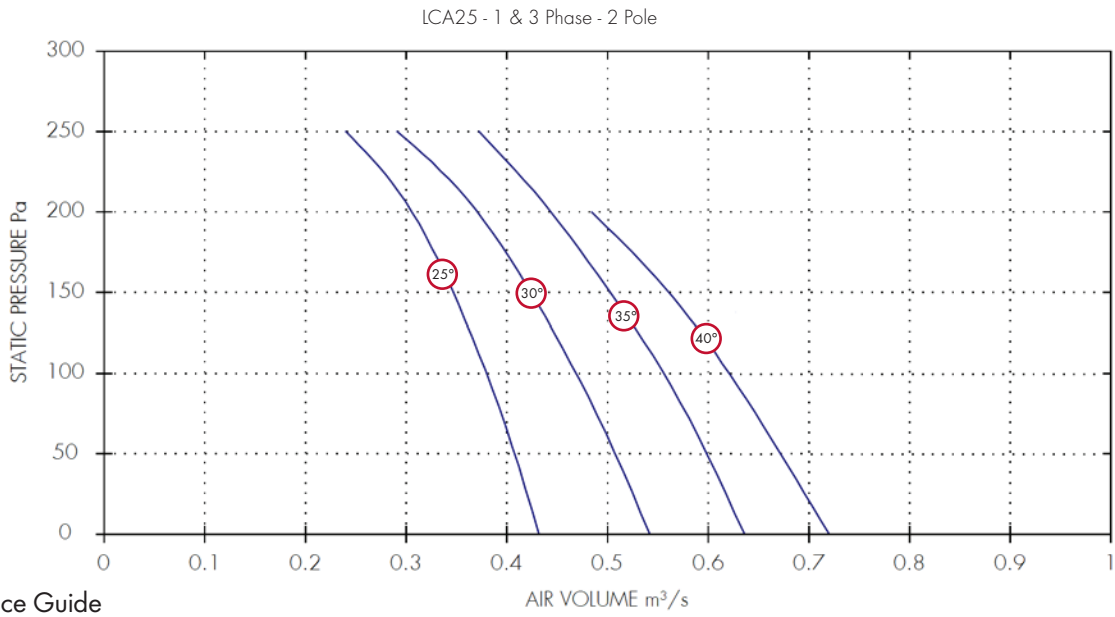

### Performance Guide

Dia.	1 Phase		3 Phase		IP Rating	Curve Ref	m³/s at Pa					Motor kW	dBA @3m	
	Stock Ref	Stock Ref	Poles	rpm			0	50	100	150	200			250
250	LCA251225	LCA253225	2	2800	IP55	25°	0.43	0.41	0.38	0.35	0.31	0.24	0.37	58
250	LCA251230	LCA253230	2	2800	IP55	30°	0.54	0.51	0.47	0.42	0.37	0.29	0.37	57
250	LCA251235	LCA253235	2	2800	IP55	35°	0.64	0.6	0.56	0.5	0.44	0.37	0.37	58
250	LCA251240	LCA253240	2	2800	IP55	40°	0.72	0.67	0.62	0.56	0.48		0.37	59

### Sound Power Level Spectra dB (ref 10<sup>-12</sup> Watts)

Dia.	1 Phase Stock		3 Phase		Spectrum	63	125	250	500	1k	2k	4k	8k	dBA @ 3m
	Stock Ref	Stock Ref	Poles	rpm										
250	LCA251225	LCA253225	2	2800	Inlet/Outlet	73	74	82	75	73	70	67	64	58
250	LCA251230	LCA253230	2	2800	Inlet/Outlet	72	73	81	74	72	69	66	63	57
250	LCA251235	LCA253235	2	2800	Inlet/Outlet	73	74	82	75	73	70	67	64	58
250	LCA251240	LCA253240	2	2800	Inlet/Outlet	74	75	83	76	74	71	68	65	59



## Performance Curves

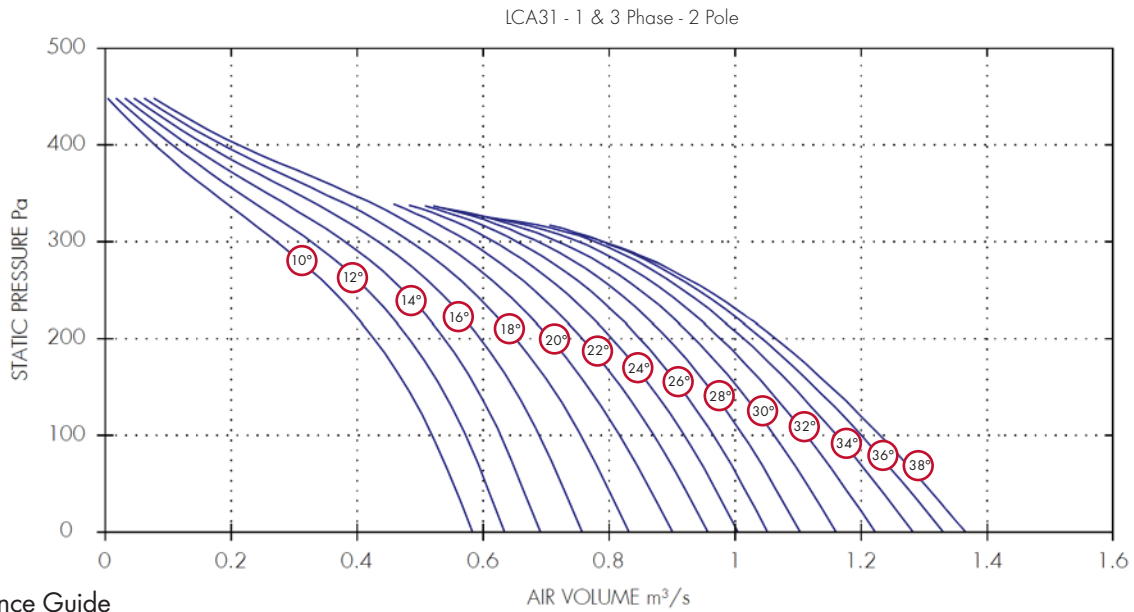

## Performance Guide

Dia.	1 Phase		3 Phase		Poles	rpm	IP Rating	Curve Ref	m³/s at Pa					Motor kW	dBA @3m
	Stock Ref	Stock Ref	0	100					200	300	400				
315	LCA311210	LCA313210	2	2800	IP55	10°	0.58	0.52	0.43	0.27	0.08	0.37	65		
315	LCA311212	LCA313212	2	2800	IP55	12°	0.63	0.57	0.48	0.33	0.11	0.37	65		
315	LCA311214	LCA313214	2	2800	IP55	14°	0.69	0.63	0.54	0.38	0.13	0.37	65		
315	LCA311216	LCA313216	2	2800	IP55	16°	0.76	0.69	0.6	0.43	0.16	0.37	63		
315	LCA311218	LCA313218	2	2800	IP55	18°	0.83	0.76	0.65	0.48	0.19	0.37	61		
315	LCA311220	LCA313220	2	2800	IP55	20°	0.9	0.82	0.71	0.53	0.21	0.37	61		
315	LCA311222	LCA313222	2	2800	IP55	22°	0.96	0.87	0.76	0.58		0.37	62		
315	LCA311224	LCA313224	2	2800	IP55	24°	1	0.92	0.8	0.62		0.37	63		
315	LCA311226	LCA313226	2	2800	IP55	26°	1.05	0.97	0.85	0.65		0.55	63		
315	LCA311228	LCA313228	2	2800	IP55	28°	1.1	1.01	0.89	0.69		0.55	63		
315	LCA311230	LCA313230	2	2800	IP55	30°	1.16	1.06	0.94	0.72		0.55	64		
315	LCA311232	LCA313232	2	2800	IP55	32°	1.22	1.11	0.98	0.75		0.55	66		
315	LCA311234	LCA313234	2	2800	IP55	34°	1.28	1.16	1.01	0.78		0.75	66		
315	LCA311236	LCA313236	2	2800	IP55	36°	1.33	1.2	1.04	0.79		0.75	66		
315	LCA311238	LCA313238	2	2800	IP55	38°	1.37	1.23	1.06	0.79		0.75	66		

## Sound Power Level Spectra dB (ref 10<sup>-12</sup> Watts)

Dia.	1 Phase		3 Phase		Poles	Spectrum	63	125	250	500	1k	2k	4k	8k	dBA @ 3m
	Stock Ref	Stock Ref													
315	LCA311210	LCA313210	2	Inlet/Outlet	83	82	82	79	81	80	76	68	65		
315	LCA311212	LCA313212	2	Inlet/Outlet	83	82	82	79	81	80	76	68	65		
315	LCA311214	LCA313214	2	Inlet/Outlet	83	82	82	79	81	80	76	68	65		
315	LCA311216	LCA313216	2	Inlet/Outlet	81	80	80	77	79	78	74	66	63		
315	LCA311218	LCA313218	2	Inlet/Outlet	79	78	78	75	77	76	72	64	61		
315	LCA311220	LCA313220	2	Inlet/Outlet	79	78	78	75	77	76	72	64	61		
315	LCA311222	LCA313222	2	Inlet/Outlet	80	79	79	76	78	77	73	65	62		
315	LCA311224	LCA313224	2	Inlet/Outlet	81	80	80	77	79	78	74	66	63		
315	LCA311226	LCA313226	2	Inlet/Outlet	81	80	80	77	79	78	74	66	63		
315	LCA311228	LCA313228	2	Inlet/Outlet	81	80	80	77	79	78	74	66	63		
315	LCA311230	LCA313230	2	Inlet/Outlet	82	81	81	78	80	79	75	67	64		
315	LCA311232	LCA313232	2	Inlet/Outlet	84	83	83	80	82	81	77	69	66		
315	LCA311234	LCA313234	2	Inlet/Outlet	84	83	83	80	82	81	77	69	66		
315	LCA311236	LCA313236	2	Inlet/Outlet	84	83	83	80	82	81	77	69	66		
315	LCA311238	LCA313238	2	Inlet/Outlet	84	83	83	80	82	81	77	69	66		

Performance Curves

LCA35 - 1 & 3 Phase - 2 Pole

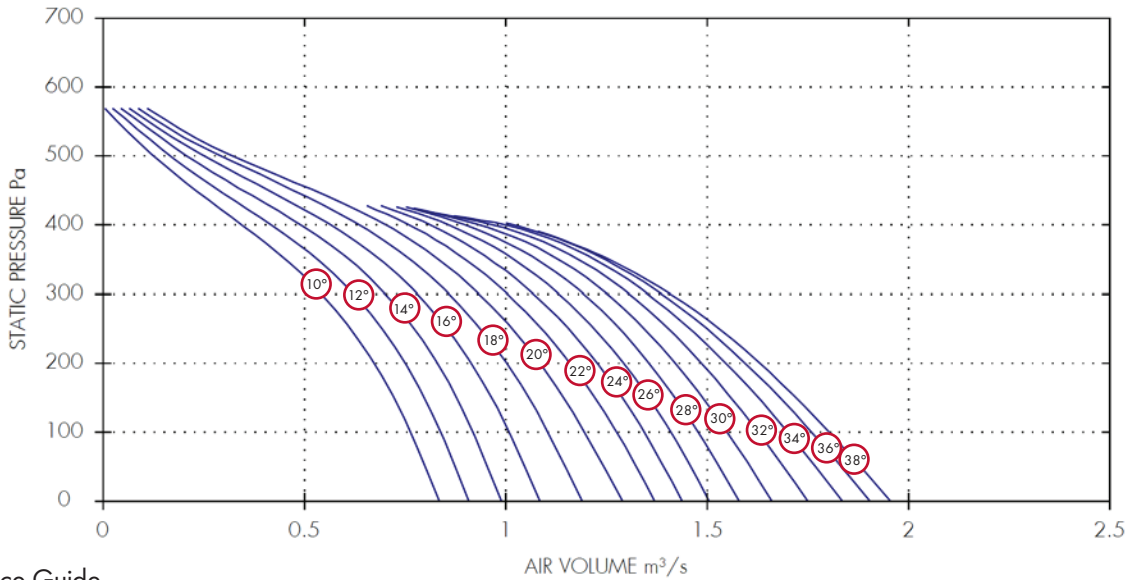

Performance Guide

Dia.	1 Phase		3 Phase		IP Rating	Curve Ref	m³/s at Pa						Motor kW	dBA @3m
	Stock Ref	Stock Ref	Poles	rpm			0	100	200	300	400	500		
355	LCA351210	LCA353210	2	2800	IP55	10°	0.84	0.76	0.67	0.54	0.34	0.13	0.37	65
355	LCA351212	LCA353212	2	2800	IP55	12°	0.91	0.84	0.75	0.62	0.42	0.17	0.37	66
355	LCA351214	LCA353214	2	2800	IP55	14°	0.99	0.92	0.83	0.7	0.49	0.21	0.55	66
355	LCA351216	LCA353216	2	2800	IP55	16°	1.08	1.01	0.92	0.78	0.56	0.25	0.55	66
355	LCA351218	LCA353218	2	2800	IP55	18°	1.19	1.1	1	0.86	0.64	0.29	0.55	66
355	LCA351220	LCA353220	2	2800	IP55	20°	1.29	1.2	1.09	0.93	0.7	0.32	0.55	66
355	LCA351222	LCA353222	2	2800	IP55	22°	1.37	1.28	1.16	1	0.76		0.75	61
355	LCA351224	LCA353224	2	2800	IP55	24°	1.44	1.34	1.23	1.07	0.81		0.75	62
355	LCA351226	LCA353226	2	2800	IP55	26°	1.51	1.41	1.29	1.13	0.86		0.75	63
355	LCA351228	LCA353228	2	2800	IP55	28°	1.58	1.48	1.36	1.19	0.9		1.1	63
355	LCA351230	LCA353230	2	2800	IP55	30°	1.66	1.55	1.42	1.25	0.93		1.1	64
355	LCA351232	LCA353232	2	2800	IP55	32°	1.75	1.63	1.49	1.31	0.97		1.1	64
355	LCA351234	LCA353234	2	2800	IP55	34°	1.84	1.7	1.55	1.35	1		1.1	64
355	LCA351236	LCA353236	2	2800	IP55	36°	1.9	1.76	1.59	1.39	1.02		1.5	64
355	LCA351238	LCA353238	2	2800	IP55	38°	1.96	1.8	1.63	1.41			1.5	64

Sound Power Level Spectra dB (ref 10<sup>-12</sup> Watts)

Dia.	1 Phase		3 Phase		Spectrum	dB @ 3m							
	Stock Ref	Stock Ref	Poles			63	125	250	500	1k	2k	4k	8k
355	LCA351210	LCA353210	2	Inlet/Outlet	83	82	82	79	81	80	76	68	65
355	LCA351212	LCA353212	2	Inlet/Outlet	84	83	83	80	82	81	77	69	66
355	LCA351214	LCA353214	2	Inlet/Outlet	84	83	83	80	82	81	77	69	66
355	LCA351216	LCA353216	2	Inlet/Outlet	84	83	83	80	82	81	77	69	66
355	LCA351218	LCA353218	2	Inlet/Outlet	84	83	83	80	82	81	77	69	66
355	LCA351220	LCA353220	2	Inlet/Outlet	84	83	83	80	82	81	77	69	66
355	LCA351222	LCA353222	2	Inlet/Outlet	79	78	78	75	77	76	72	64	61
355	LCA351224	LCA353224	2	Inlet/Outlet	80	79	79	76	78	77	73	65	62
355	LCA351226	LCA353226	2	Inlet/Outlet	81	80	80	77	79	78	74	66	63
355	LCA351228	LCA353228	2	Inlet/Outlet	81	80	80	77	79	78	74	66	63
355	LCA351230	LCA353230	2	Inlet/Outlet	82	81	81	78	80	79	75	67	64
355	LCA351232	LCA353232	2	Inlet/Outlet	82	81	81	78	80	79	75	67	64
355	LCA351234	LCA353234	2	Inlet/Outlet	82	81	81	78	80	79	75	67	64
355	LCA351236	LCA353236	2	Inlet/Outlet	82	81	81	78	80	79	75	67	64
355	LCA351238	LCA353238	2	Inlet/Outlet	82	81	81	78	80	79	75	67	64

Performance Curves

LCA40 - 1 & 3 Phase - 2 Pole

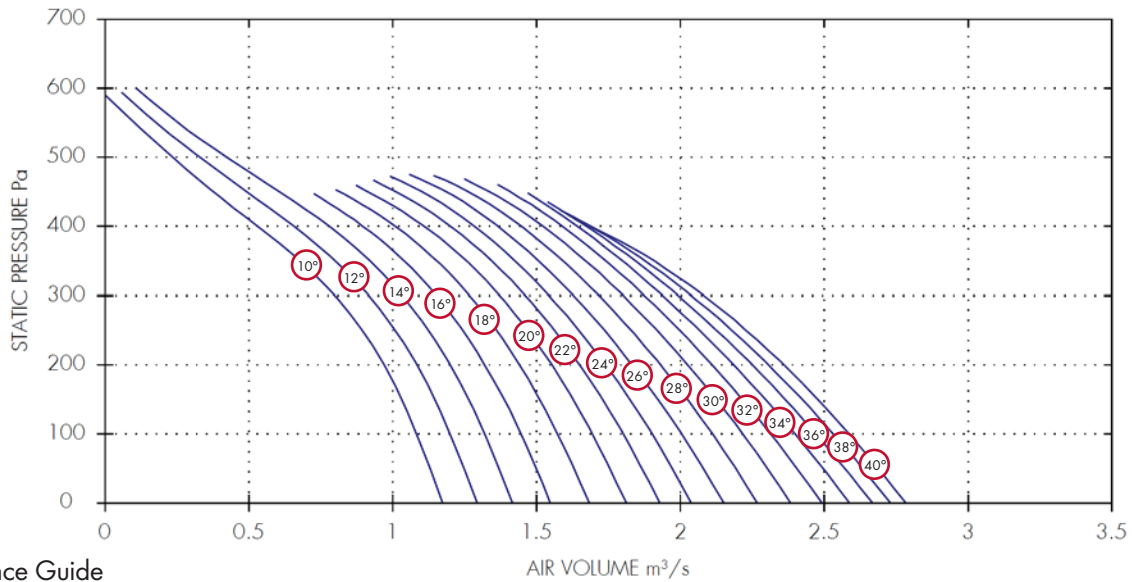

Performance Guide

Dia.	1 Phase		3 Phase		IP	Curve	m³/s at Pa						Motor kW	dBA @3m
	Stock Ref	Stock Ref	Poles	rpm			Rating	Ref	0	100	200	300		
400	LCA401210	LCA403210	2	2800	IP55	10°	1.17	1.08	0.97	0.8	0.53	0.23	0.55	71
400	LCA401212	LCA403212	2	2800	IP55	12°	1.29	1.2	1.09	0.92	0.66	0.33	0.55	71
400	LCA401214	LCA403214	2	2800	IP55	14°	1.42	1.32	1.2	1.03	0.78	0.42	0.75	71
400	LCA401216	LCA403216	2	2800	IP55	16°	1.55	1.45	1.32	1.15	0.9		0.75	71
400	LCA401218	LCA403218	2	2800	IP55	18°	1.68	1.57	1.44	1.27	1.01		0.75	71
400	LCA401220	LCA403220	2	2800	IP55	20°	1.81	1.69	1.55	1.37	1.11		1.1	71
400	LCA401222	LCA403222	2	2800	IP55	22°	1.93	1.8	1.65	1.46	1.2		1.1	66
400	LCA401224	LCA403224	2	2800	IP55	24°	2.04	1.9	1.74	1.54	1.28		1.1	66
400	LCA401226	LCA403226	2	2800	IP55	26°	2.15	2	1.83	1.63	1.37		1.1	67
400	LCA401228	LCA403228	2	2800	IP55	28°	2.27	2.11	1.93	1.72	1.45		1.5	68
400	LCA401230	LCA403230	2	2800	IP55	30°	2.38	2.22	2.03	1.8	1.52		1.5	68
400	LCA401232	LCA403232	2	2800	IP55	32°	2.49	2.31	2.11	1.88	1.59		1.5	68
400	-	LCA403234	2	2800	IP55	34°	2.59	2.4	2.19	1.94	1.64		2.2	67
400	-	LCA403236	2	2800	IP55	36°	2.67	2.47	2.25	1.99	1.67		2.2	66
400	-	LCA403238	2	2800	IP55	38°	2.73	2.53	2.31	2.04	1.69		2.2	66
400	-	LCA403240	2	2800	IP55	40°	2.78	2.59	2.36	2.08	1.69		3	66

Sound Power Level Spectra dB (ref 10<sup>-12</sup> Watts)

Dia.	1 Phase Stock Ref		3 Phase Stock Ref		Poles	Spectrum	dB										
	63	125	250	500			1k	2k	4k	8k	dBA @ 3m						
400	LCA401210	LCA403210	2	Inlet/Outlet	89	86	89	86	87	84	81	74	71				
400	LCA401212	LCA403212	2	Inlet/Outlet	89	86	89	86	87	84	81	74	71				
400	LCA401214	LCA403214	2	Inlet/Outlet	89	86	89	86	87	84	81	74	71				
400	LCA401216	LCA403216	2	Inlet/Outlet	89	86	89	86	87	84	81	74	71				
400	LCA401218	LCA403218	2	Inlet/Outlet	89	86	89	86	87	84	81	74	71				
400	LCA401220	LCA403220	2	Inlet/Outlet	89	86	89	86	87	84	81	74	71				
400	LCA401222	LCA403222	2	Inlet/Outlet	84	81	84	81	82	79	76	69	66				
400	LCA401224	LCA403224	2	Inlet/Outlet	84	81	84	81	82	79	76	69	66				
400	LCA401226	LCA403226	2	Inlet/Outlet	85	82	85	82	83	80	77	70	67				
400	LCA401228	LCA403228	2	Inlet/Outlet	86	83	86	83	84	81	78	71	68				
400	LCA401230	LCA403230	2	Inlet/Outlet	86	83	86	83	84	81	78	71	68				
400	LCA401232	LCA403232	2	Inlet/Outlet	86	83	86	83	84	81	78	71	68				
400	-	LCA403234	2	Inlet/Outlet	85	82	85	82	83	80	77	70	67				
400	-	LCA403236	2	Inlet/Outlet	84	81	84	81	82	79	76	69	66				
400	-	LCA403238	2	Inlet/Outlet	84	81	84	81	82	79	76	69	66				
400	-	LCA403240	2	Inlet/Outlet	84	81	84	81	82	79	76	69	66				

Performance Curves

LCA45 - 3 Phase - 2 Pole

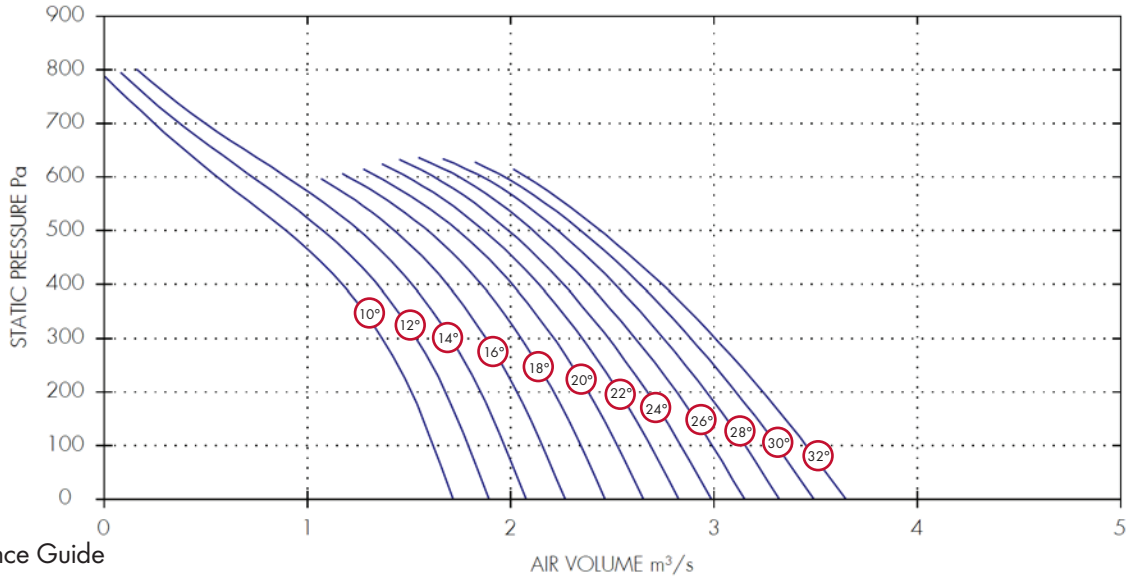

Performance Guide

Dia.	3 Phase		rpm	IP Rating	Curve Ref	m³/s at Pa								Motor kW	dBA @3m
	Stock Ref	Poles				0	100	200	300	400	500	600	700		
450	LCA453210	2	2880	IP55	10°	1.72	1.62	1.51	1.37	1.17	0.89	0.56	0.25	1.1	74
450	LCA453212	2	2880	IP55	12°	1.89	1.79	1.68	1.54	1.34	1.08	0.73	0.37	1.1	73
450	LCA453214	2	2880	IP55	14°	2.08	1.97	1.85	1.7	1.51	1.26	0.9	0.5	1.5	72
450	LCA453216	2	2880	IP55	16°	2.27	2.16	2.03	1.88	1.69	1.43			1.5	71
450	LCA453218	2	2880	IP55	18°	2.47	2.35	2.21	2.05	1.86	1.59	1.2		1.5	70
450	LCA453220	2	2880	IP55	20°	2.65	2.53	2.38	2.21	2.01	1.74	1.35		2.2	70
450	LCA453222	2	2880	IP55	22°	2.82	2.69	2.53	2.35	2.14	1.87	1.49		2.2	70
450	LCA453224	2	2880	IP55	24°	2.99	2.84	2.67	2.48	2.26	1.99	1.62		2.2	70
450	LCA453226	2	2880	IP55	26°	3.15	2.99	2.82	2.61	2.38	2.11	1.75		2.2	70
450	LCA453228	2	2880	IP55	28°	3.32	3.15	2.96	2.75	2.51	2.23	1.86		3	70
450	LCA453230	2	2880	IP55	30°	3.49	3.31	3.11	2.89	2.64	2.35	1.97		3	70
450	LCA453232	2	2880	IP55	32°	3.65	3.45	3.24	3.01	2.74	2.44	2.08		3	70

Sound Power Level Spectra dB (ref 10<sup>-12</sup> Watts)

Dia.	3 Phase		Spectrum	dB								dBA @ 3m
	Stock Ref	Poles		63	125	250	500	1k	2k	4k	8k	
450	LCA453210	2	Inlet/Outlet	92	89	92	89	90	87	84	77	74
450	LCA453212	2	Inlet/Outlet	91	88	91	88	89	86	83	76	73
450	LCA453214	2	Inlet/Outlet	90	87	90	87	88	85	82	75	72
450	LCA453216	2	Inlet/Outlet	89	86	89	86	87	84	81	74	71
450	LCA453218	2	Inlet/Outlet	88	85	88	85	86	83	80	73	70
450	LCA453220	2	Inlet/Outlet	88	85	88	85	86	83	80	73	70
450	LCA453222	2	Inlet/Outlet	88	85	88	85	86	83	80	73	70
450	LCA453224	2	Inlet/Outlet	88	85	88	85	86	83	80	73	70
450	LCA453226	2	Inlet/Outlet	88	85	88	85	86	83	80	73	70
450	LCA453228	2	Inlet/Outlet	88	85	88	85	86	83	80	73	70
450	LCA453230	2	Inlet/Outlet	88	85	88	85	86	83	80	73	70
450	LCA453232	2	Inlet/Outlet	88	85	88	85	86	83	80	73	70

Performance Curves

LCA50 - 3 Phase - 2 Pole

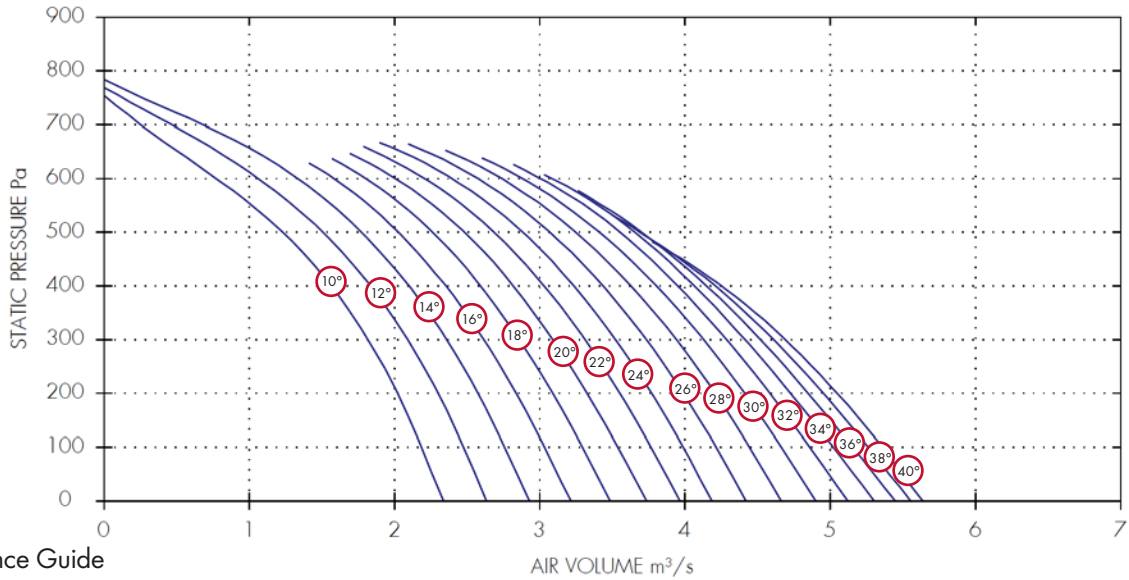

Performance Guide

Dia.	3 Phase		rpm	IP Rating	Curve Ref	m³/s at Pa								Motor kW	dBA @3m
	Stock Ref	Poles				0	100	200	300	400	500	600	700		
500	LCA503210	2	2880	IP55	10°	2.34	2.19	2.02	1.82	1.56	1.23	0.77	0.25	1.5	74
500	LCA503212	2	2880	IP55	12°	2.64	2.48	2.3	2.09	1.83	1.51	1.06	0.46	1.5	73
500	LCA503214	2	2880	IP55	14°	2.93	2.76	2.57	2.36	2.1	1.77	1.33	0.68	2.2	72
500	LCA503216	2	2880	IP55	16°	3.21	3.04	2.84	2.62	2.35	2.03	1.58		2.2	71
500	LCA503218	2	2880	IP55	18°	3.48	3.29	3.09	2.86	2.59	2.26	1.8		2.2	71
500	LCA503220	2	2880	IP55	20°	3.73	3.54	3.33	3.09	2.82	2.48	2.01		3	71
500	LCA503222	2	2880	IP55	22°	3.96	3.77	3.55	3.31	3.03	2.69	2.21		3	71
500	LCA503224	2	2880	IP55	24°	4.19	3.99	3.77	3.52	3.24	2.88	2.4		3	71
500	LCA503226	2	2880	IP55	26°	4.42	4.21	3.99	3.73	3.44	3.07	2.58		4	71
500	LCA503228	2	2880	IP55	28°	4.66	4.45	4.21	3.94	3.63	3.25	2.74		4	72
500	LCA503230	2	2880	IP55	30°	4.9	4.67	4.41	4.13	3.8	3.41	2.88		4	72
500	LCA503232	2	2880	IP55	32°	5.12	4.86	4.58	4.28	3.95	3.55	3		5.5	72
500	LCA503234	2	2880	IP55	34°	5.3	5.02	4.73	4.41	4.07	3.66	3.08		5.5	72
500	LCA503236	2	2880	IP55	36°	5.45	5.16	4.85	4.52	4.15	3.7			5.5	72
500	LCA503238	2	2880	IP55	38°	5.55	5.26	4.95	4.61	4.21	3.69			7.5	72
500	LCA503240	2	2880	IP55	40°	5.64	5.36	5.05	4.69	4.25				7.5	72

Sound Power Level Spectra dB (ref 10<sup>-12</sup> Watts)

Dia.	Stock Ref	Poles	Spectrum	63	125	250	500	1k	2k	4k	8k	dBA @ 3m
500	LCA503210	2	Inlet/Outlet	93	84	91	91	91	87	85	78	74
500	LCA503212	2	Inlet/Outlet	92	83	90	90	90	86	84	77	73
500	LCA503214	2	Inlet/Outlet	91	82	89	89	89	85	83	76	72
500	LCA503216	2	Inlet/Outlet	90	81	88	88	88	84	82	75	71
500	LCA503218	2	Inlet/Outlet	90	81	88	88	88	84	82	75	71
500	LCA503220	2	Inlet/Outlet	90	81	88	88	88	84	82	75	71
500	LCA503222	2	Inlet/Outlet	90	81	88	88	88	84	82	75	71
500	LCA503224	2	Inlet/Outlet	90	81	88	88	88	84	82	75	71
500	LCA503226	2	Inlet/Outlet	90	81	88	88	88	84	82	75	71
500	LCA503228	2	Inlet/Outlet	91	82	89	89	89	85	83	76	72
500	LCA503230	2	Inlet/Outlet	91	82	89	89	89	85	83	76	72
500	LCA503232	2	Inlet/Outlet	91	82	89	89	89	85	83	76	72
500	LCA503234	2	Inlet/Outlet	91	82	89	89	89	85	83	76	72
500	LCA503236	2	Inlet/Outlet	91	82	89	89	89	85	83	76	72
500	LCA503238	2	Inlet/Outlet	91	82	89	89	89	85	83	76	72
500	LCA503240	2	Inlet/Outlet	91	82	89	89	89	85	83	76	72

Performance Curve

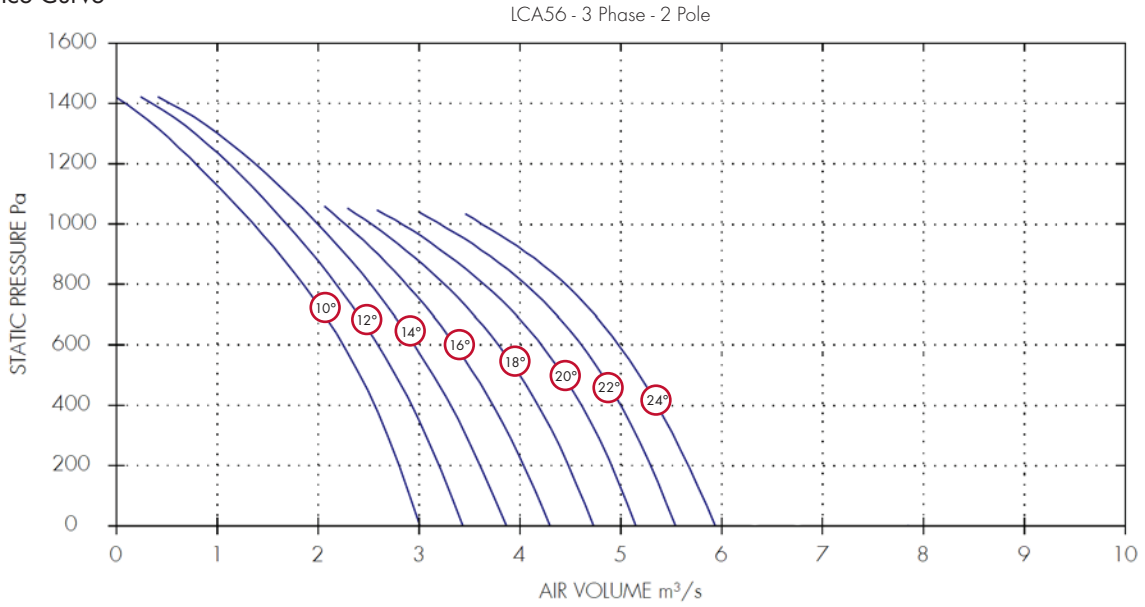

Performance Guide

Dia.	3 Phase		rpm	IP Rating	Curve Ref	m³/s at Pa								Motor kW	dBA @3m
	Stock Ref	Poles				0	200	400	600	800	1000	1200	1400		
560	LCA563210	2	2880	IP55	10°	3.01	2.8	2.56	2.25	1.85	1.36	0.79	0.09	4	79
560	LCA563212	2	2880	IP55	12°	3.44	3.2	2.93	2.59	2.18	1.69	1.11	0.35	4	79
560	LCA563214	2	2880	IP55	14°	3.87	3.61	3.31	2.95	2.52	1.99	1.37	0.53	4	79
560	LCA563216	2	2880	IP55	16°	4.3	4.04	3.73	3.36	2.88	2.27			5.5	79
560	LCA563218	2	2880	IP55	18°	4.73	4.48	4.18	3.79	3.25	2.53			5.5	79
560	LCA563220	2	2880	IP55	20°	5.15	4.91	4.61	4.21	3.65	2.83			7.5	79
560	LCA563222	2	2880	IP55	22°	5.54	5.3	5	4.61	4.05	3.21			7.5	79
560	LCA563224	2	2880	IP55	24°	5.94	5.67	5.36	4.98	4.45	3.62			7.5	79

Sound Power Level Spectra dB (ref 10<sup>-12</sup> Watts)

Dia.	3 Phase		Spectrum	dB								dBA @ 3m
	Stock Ref	Poles		63	125	250	500	1k	2k	4k	8k	
560	LCA563210	2	Inlet/Outlet	94	89	97	98	94	91	86	82	79
560	LCA563212	2	Inlet/Outlet	94	89	97	98	94	91	86	82	79
560	LCA563214	2	Inlet/Outlet	94	89	97	98	94	91	86	82	79
560	LCA563216	2	Inlet/Outlet	94	89	97	98	94	91	86	82	79
560	LCA563218	2	Inlet/Outlet	94	89	97	98	94	91	86	82	79
560	LCA563220	2	Inlet/Outlet	94	89	97	98	94	91	86	82	79
560	LCA563222	2	Inlet/Outlet	94	89	97	98	94	91	86	82	79
560	LCA563224	2	Inlet/Outlet	94	89	97	98	94	91	86	82	79
560	LCA563226	2	Inlet/Outlet	94	89	97	98	94	91	86	82	79

Performance Curve

LCA63 - 3 Phase - 2 Pole

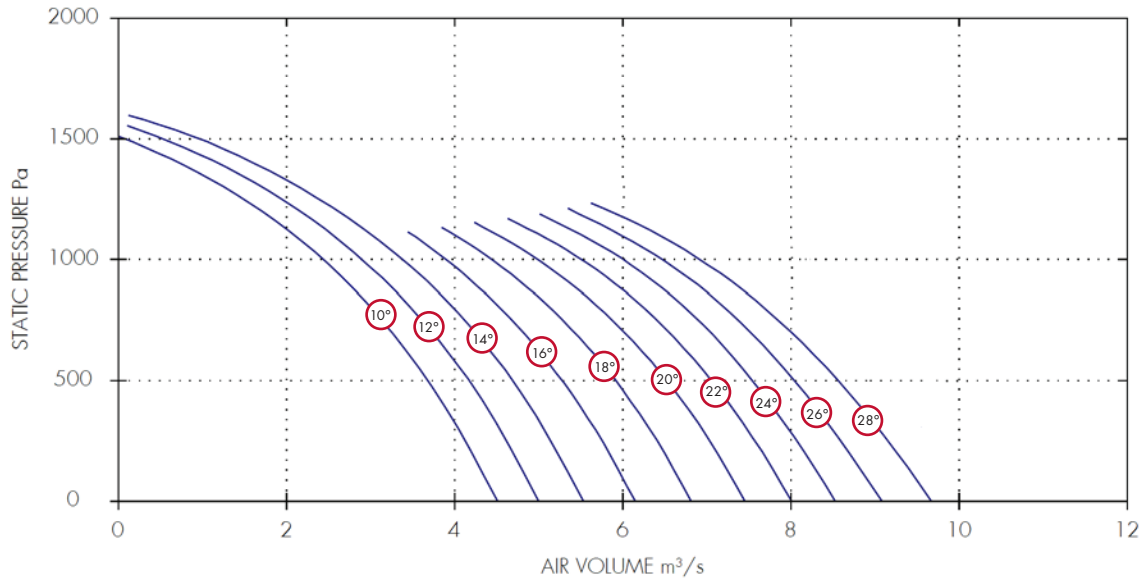

Performance Guide

Dia.	3 Phase		rpm	IP Rating	Curve Ref	m³/s at Pa								Motor kW	dBA @3m
	Stock Ref	Poles				0	200	400	600	800	1000	1200	1400		
630	LCA633210	2	2940	IP55	10°	4.51	4.2	3.87	3.47	3.01	2.44	1.7	0.72	5.5	84
630	LCA633212	2	2940	IP55	12°	5	4.7	4.36	3.96	3.48	2.9	2.16	1.17	5.5	84
630	LCA633214	2	2940	IP55	14°	5.53	5.22	4.88	4.48	3.98	3.38	2.61	1.6	7.5	84
630	LCA633216	2	2940	IP55	16°	6.15	5.84	5.48	5.06	4.54	3.89			7.5	84
630	LCA633218	2	2940	IP55	18°	6.81	6.5	6.13	5.68	5.14	4.44			11	84
630	LCA633220	2	2940	IP55	20°	7.46	7.12	6.74	6.28	5.72	4.98			11	84
630	LCA633222	2	2940	IP55	22°	8.01	7.67	7.27	6.82	6.25	5.51			11	84
630	LCA633224	2	2940	IP55	24°	8.53	8.17	7.76	7.3	6.74	6			15	84
630	LCA633226	2	2940	IP55	26°	9.08	8.7	8.27	7.79	7.22	6.47	5.41		15	84
630	LCA633228	2	2940	IP55	28°	9.67	9.26	8.81	8.3	7.69	6.92	5.85		15	84

Sound Power Level Spectra dB (ref 10<sup>-12</sup> Watts)

Dia.	Stock Ref	Poles	Spectrum	63	125	250	500	1k	2k	4k	8k	dBA @ 3m
630	LCA633210	2	Inlet/Outlet	99	94	102	103	99	96	91	87	84
630	LCA633212	2	Inlet/Outlet	99	94	102	103	99	96	91	87	84
630	LCA633214	2	Inlet/Outlet	99	94	102	103	99	96	91	87	84
630	LCA633216	2	Inlet/Outlet	99	94	102	103	99	96	91	87	84
630	LCA633218	2	Inlet/Outlet	99	94	102	103	99	96	91	87	84
630	LCA633220	2	Inlet/Outlet	99	94	102	103	99	96	91	87	84
630	LCA633222	2	Inlet/Outlet	99	94	102	103	99	96	91	87	84
630	LCA633224	2	Inlet/Outlet	99	94	102	103	99	96	91	87	84
630	LCA633226	2	Inlet/Outlet	99	94	102	103	99	96	91	87	84
630	LCA633228	2	Inlet/Outlet	99	94	102	103	99	96	91	87	84



Performance Curve

LCA25 - 1 & 3 Phase - 4 Pole

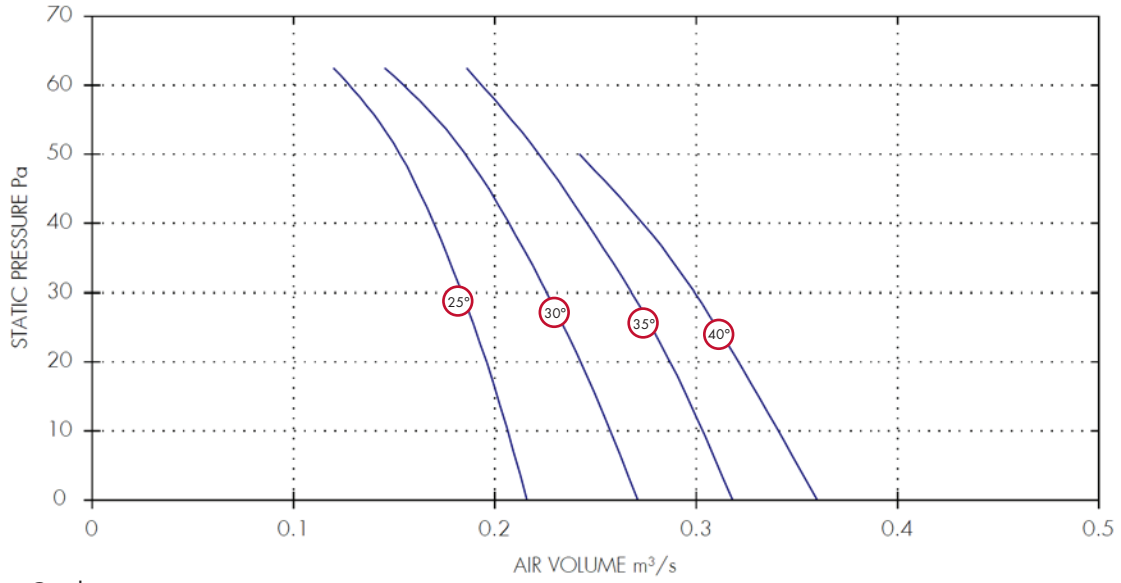

Performance Guide

Dia.	1 Phase		3 Phase		IP	Curve Ref	m³/s at Pa							Motor kW	dBA @3m
	Stock Ref	Stock Ref	Poles	rpm			Rating	0	10	20	30	40	50		
250	LCA251425	LCA253425	4	1400	IP55	25°	0.22	0.21	0.2	0.18	0.17	0.15	0.13	0.25	46
250	LCA251430	LCA253430	4	1400	IP55	30°	0.27	0.26	0.24	0.23	0.21	0.19	0.15	0.25	45
250	LCA251435	LCA253435	4	1400	IP55	35°	0.32	0.3	0.29	0.27	0.25	0.22	0.19	0.25	46
250	LCA251440	LCA253440	4	1400	IP55	40°	0.36	0.34	0.32	0.3	0.27	0.24	0.2	0.25	46

Sound Power Level Spectra dB (ref 10<sup>-12</sup> Watts)

Dia.	1 Phase		3 Phase		Spectrum	63	125	250	500	1k	2k	4k	8k	dBA @3m
	Stock Ref	Stock Ref	Poles	rpm										
250	LCA251425	LCA253425	4	1400	Inlet/Outlet	61	68	64	63	61	58	55	52	46
250	LCA251430	LCA253430	4	1400	Inlet/Outlet	60	67	63	62	60	57	54	51	45
250	LCA251435	LCA253435	4	1400	Inlet/Outlet	61	68	64	63	61	58	55	52	46
250	LCA251440	LCA253440	4	1400	Inlet/Outlet	61	68	64	63	61	58	55	52	46

Performance Curve

LCA31 - 1 & 3 Phase - 4 Pole

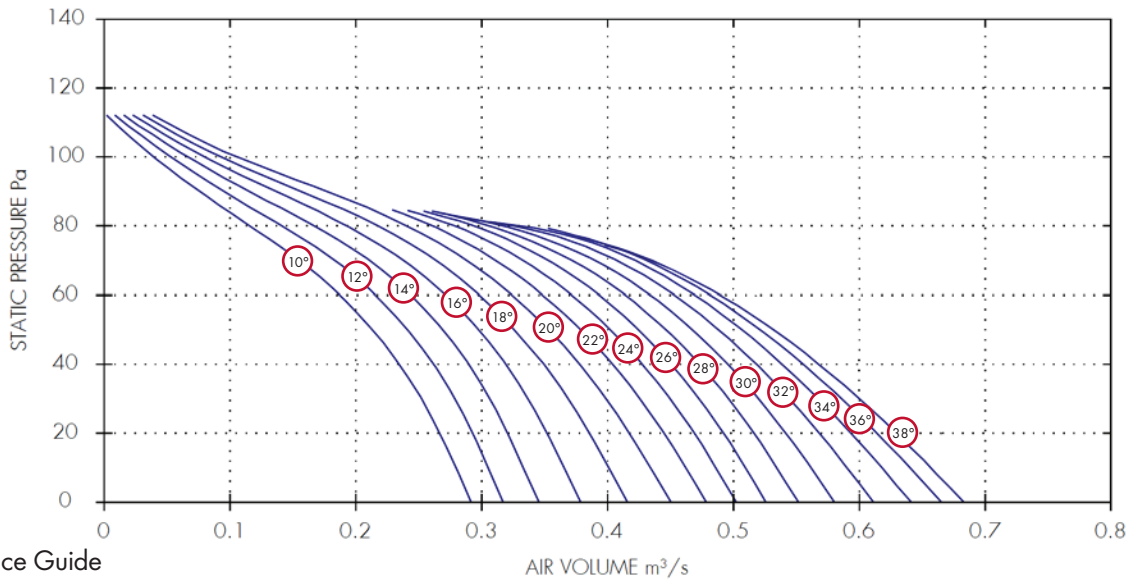

Performance Guide

Dia.	1 Phase		3 Phase		IP	Curve	m³/s at Pa						Motor kW	dBA @3m
	Stock Ref	Stock Ref	Poles	rpm			Rating	Ref	0	20	40	60		
315	LCA311410	LCA313410	4	1400	IP55	10°	0.29	0.27	0.23	0.19	0.12	0.04	0.25	49
315	LCA311412	LCA313412	4	1400	IP55	12°	0.32	0.29	0.26	0.22	0.14	0.05	0.25	49
315	LCA311414	LCA313414	4	1400	IP55	14°	0.35	0.32	0.29	0.24	0.17	0.07	0.25	49
315	LCA311416	LCA313416	4	1400	IP55	16°	0.38	0.35	0.32	0.27	0.19	0.08	0.25	44
315	LCA311418	LCA313418	4	1400	IP55	18°	0.42	0.39	0.35	0.3	0.22	0.09	0.25	44
315	LCA311420	LCA313420	4	1400	IP55	20°	0.45	0.42	0.38	0.32	0.24	0.11	0.25	44
315	LCA311422	LCA313422	4	1400	IP55	22°	0.48	0.45	0.4	0.35	0.26		0.25	44
315	LCA311424	LCA313424	4	1400	IP55	24°	0.5	0.47	0.43	0.37	0.28		0.25	46
315	LCA311426	LCA313426	4	1400	IP55	26°	0.53	0.49	0.45	0.39	0.29		0.25	46
315	LCA311428	LCA313428	4	1400	IP55	28°	0.55	0.52	0.47	0.41	0.31		0.25	46
315	LCA311430	LCA313430	4	1400	IP55	30°	0.58	0.54	0.5	0.43	0.32		0.25	46
315	LCA311432	LCA313432	4	1400	IP55	32°	0.61	0.57	0.52	0.45	0.32		0.25	48
315	LCA311434	LCA313434	4	1400	IP55	34°	0.64	0.59	0.54	0.47	0.33		0.25	48
315	LCA311436	LCA313436	4	1400	IP55	36°	0.67	0.61	0.56	0.48			0.25	48
315	LCA311438	LCA313438	4	1400	IP55	38°	0.68	0.63	0.57	0.49			0.25	48

Sound Power Level Spectra dB (ref 10<sup>-12</sup> Watts)

Dia.	1 Phase		3 Phase		Spectrum	dB											
	Stock Ref	Stock Ref	Poles	Rating		63	125	250	500	1k	2k	4k	8k	dBA @3m			
315	LCA311410	LCA313410	4	IP55	Inlet/Outlet	66	69	67	64	65	63	58	48	49			
315	LCA311412	LCA313412	4	IP55	Inlet/Outlet	66	69	67	64	65	63	58	48	49			
315	LCA311414	LCA313414	4	IP55	Inlet/Outlet	66	69	67	64	65	63	58	48	49			
315	LCA311416	LCA313416	4	IP55	Inlet/Outlet	61	64	62	59	60	58	53	43	44			
315	LCA311418	LCA313418	4	IP55	Inlet/Outlet	61	64	62	59	60	58	53	43	44			
315	LCA311420	LCA313420	4	IP55	Inlet/Outlet	61	64	62	59	60	58	53	43	44			
315	LCA311422	LCA313422	4	IP55	Inlet/Outlet	61	64	62	59	60	58	53	43	44			
315	LCA311424	LCA313424	4	IP55	Inlet/Outlet	63	66	64	61	62	60	55	45	46			
315	LCA311426	LCA313426	4	IP55	Inlet/Outlet	63	66	64	61	62	60	55	45	46			
315	LCA311428	LCA313428	4	IP55	Inlet/Outlet	63	66	64	61	62	60	55	45	46			
315	LCA311430	LCA313430	4	IP55	Inlet/Outlet	63	66	64	61	62	60	55	45	46			
315	LCA311432	LCA313432	4	IP55	Inlet/Outlet	65	68	66	63	64	62	57	47	48			
315	LCA311434	LCA313434	4	IP55	Inlet/Outlet	65	68	66	63	64	62	57	47	48			
315	LCA311436	LCA313436	4	IP55	Inlet/Outlet	65	68	66	63	64	62	57	47	48			
315	LCA311438	LCA313438	4	IP55	Inlet/Outlet	65	68	66	63	64	62	57	47	48			
315	LCA311440	LCA313440	4	IP55	Inlet/Outlet	65	68	66	63	64	62	57	47	48			

Performance Curve

LCA35 - 1 & 3 Phase - 4 Pole

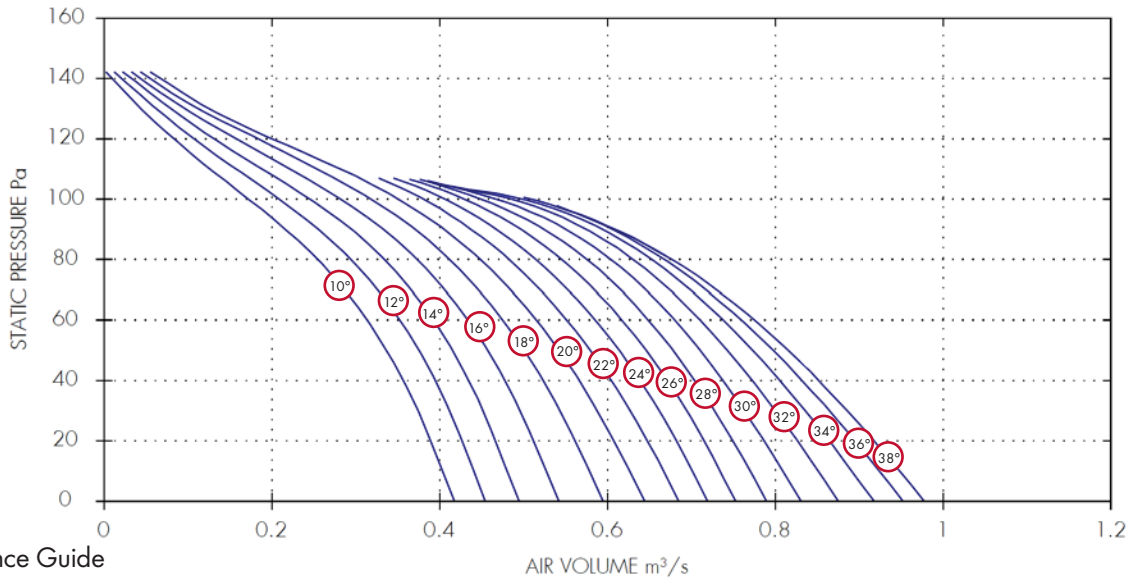

Performance Guide

Dia.	1 Phase		Poles	rpm	IP Rating	Curve Ref	AIR VOLUME m <sup>3</sup> /s								Motor kW	dBA @3m
	Stock Ref	3 Phase Stock Ref					0	20	40	60	80	100	120	140		
355	LCA351410	LCA353410	4	1400	IP55	10°	0.42	0.39	0.36	0.31	0.25	0.17	0.08	0.01	0.25	50
355	LCA351412	LCA353412	4	1400	IP55	12°	0.45	0.43	0.39	0.35	0.29	0.21	0.11	0.02	0.25	50
355	LCA351414	LCA353414	4	1400	IP55	14°	0.49	0.47	0.43	0.39	0.33	0.25	0.13	0.03	0.25	50
355	LCA351416	LCA353416	4	1400	IP55	16°	0.54	0.51	0.48	0.43	0.37	0.28	0.16	0.04	0.25	50
355	LCA351418	LCA353418	4	1400	IP55	18°	0.6	0.56	0.52	0.48	0.41	0.32	0.18	0.06	0.25	50
355	LCA351420	LCA353420	4	1400	IP55	20°	0.64	0.61	0.57	0.52	0.45	0.35	0.2	0.07	0.25	50
355	LCA351422	LCA353422	4	1400	IP55	22°	0.68	0.65	0.6	0.55	0.48	0.38			0.25	45
355	LCA351424	LCA353424	4	1400	IP55	24°	0.72	0.68	0.64	0.59	0.51	0.41			0.25	45
355	LCA351426	LCA353426	4	1400	IP55	26°	0.75	0.72	0.67	0.62	0.55	0.43			0.25	46
355	LCA351428	LCA353428	4	1400	IP55	28°	0.79	0.75	0.7	0.65	0.58	0.45			0.25	47
355	LCA351430	LCA353430	4	1400	IP55	30°	0.83	0.79	0.74	0.68	0.6	0.47			0.25	47
355	LCA351432	LCA353432	4	1400	IP55	32°	0.87	0.83	0.77	0.71	0.63	0.48			0.25	48
355	LCA351434	LCA353434	4	1400	IP55	34°	0.92	0.86	0.81	0.74	0.65	0.5			0.25	48
355	LCA351436	LCA353436	4	1400	IP55	36°	0.95	0.89	0.83	0.76	0.67	0.51			0.25	48
355	LCA351438	LCA353438	4	1400	IP55	38°	0.98	0.92	0.85	0.78	0.68				0.25	48

Sound Power Level Spectra dB (ref 10<sup>-12</sup> Watts)

Dia.	1 Phase		Poles	Spectrum	dB								dBA @3m
	Stock Ref	3 Phase Stock Ref			63	125	250	500	1k	2k	4k	8k	
355	LCA351410	LCA353410	4	Inlet/Outlet	67	70	68	65	66	64	59	49	50
355	LCA351412	LCA353412	4	Inlet/Outlet	67	70	68	65	66	64	59	49	50
355	LCA351414	LCA353414	4	Inlet/Outlet	67	70	68	65	66	64	59	49	50
355	LCA351416	LCA353416	4	Inlet/Outlet	67	70	68	65	66	64	59	49	50
355	LCA351418	LCA353418	4	Inlet/Outlet	67	70	68	65	66	64	59	49	50
355	LCA351420	LCA353420	4	Inlet/Outlet	67	70	68	65	66	64	59	49	50
355	LCA351422	LCA353422	4	Inlet/Outlet	62	65	63	60	61	59	54	44	45
355	LCA351424	LCA353424	4	Inlet/Outlet	62	65	63	60	61	59	54	44	45
355	LCA351426	LCA353426	4	Inlet/Outlet	63	66	64	61	62	60	55	45	46
355	LCA351428	LCA353428	4	Inlet/Outlet	64	67	65	62	63	61	56	46	47
355	LCA351430	LCA353430	4	Inlet/Outlet	64	67	65	62	63	61	56	46	47
355	LCA351432	LCA353432	4	Inlet/Outlet	65	68	66	63	64	62	57	47	48
355	LCA351434	LCA353434	4	Inlet/Outlet	65	68	66	63	64	62	57	47	48
355	LCA351436	LCA353436	4	Inlet/Outlet	65	68	66	63	64	62	57	47	48
355	LCA351438	LCA353438	4	Inlet/Outlet	65	68	66	63	64	62	57	47	48

Performance Curve

LCA40 - 1 & 3 Phase - 4 Pole

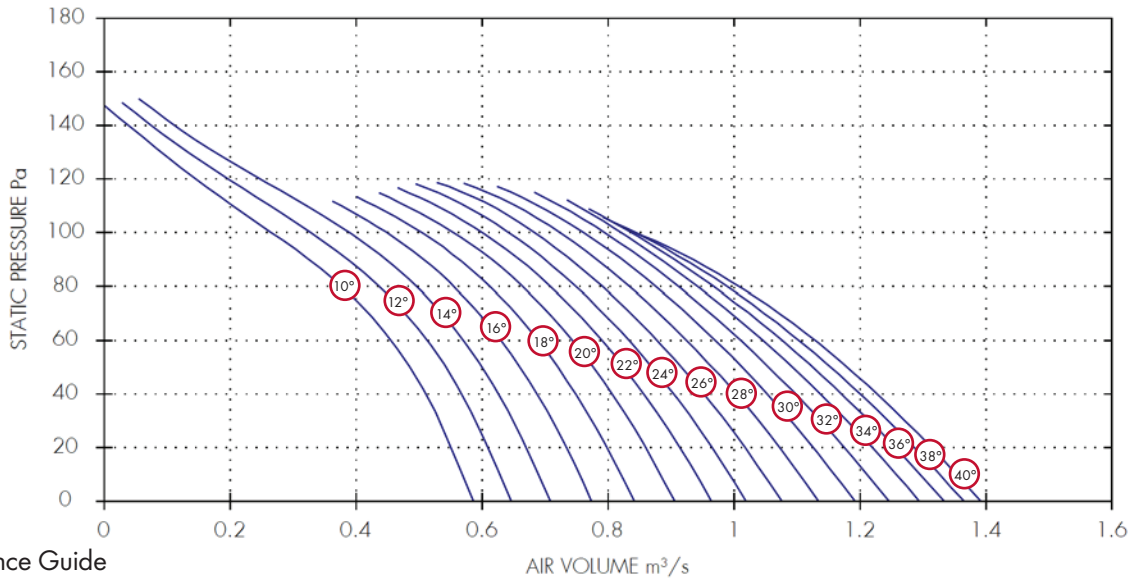

Performance Guide

Dia.	1 Phase		3 Phase		IP	Curve	AIR VOLUME m³/s								Motor kW	dBA @3m
	Stock Ref	Stock Ref	Poles	rpm			Rating	Ref	0	20	40	60	80	100		
400	LCA401410	LCA403410	4	1400	IP55	10°	0.59	0.55	0.51	0.46	0.38	0.27	0.15	0.04	0.25	54
400	LCA401412	LCA403412	4	1400	IP55	12°	0.65	0.61	0.57	0.51	0.44	0.33	0.2	0.08	0.25	54
400	LCA401414	LCA403414	4	1400	IP55	14°	0.71	0.67	0.63	0.57	0.5	0.39	0.25	0.11	0.25	54
400	LCA401416	LCA403416	4	1400	IP55	16°	0.77	0.73	0.69	0.63	0.56	0.45			0.25	54
400	LCA401418	LCA403418	4	1400	IP55	18°	0.84	0.8	0.75	0.69	0.61	0.5			0.25	54
400	LCA401420	LCA403420	4	1400	IP55	20°	0.91	0.86	0.81	0.74	0.66	0.55			0.25	54
400	LCA401422	LCA403422	4	1400	IP55	22°	0.96	0.91	0.86	0.79	0.71	0.6			0.25	48
400	LCA401424	LCA403424	4	1400	IP55	24°	1.02	0.97	0.9	0.83	0.75	0.64			0.25	48
400	LCA401426	LCA403426	4	1400	IP55	26°	1.08	1.02	0.95	0.88	0.79	0.68			0.25	50
400	LCA401428	LCA403428	4	1400	IP55	28°	1.13	1.07	1	0.92	0.83	0.72			0.25	51
400	LCA401430	LCA403430	4	1400	IP55	30°	1.19	1.13	1.05	0.97	0.88	0.76			0.25	52
400	LCA401432	LCA403432	4	1400	IP55	32°	1.25	1.18	1.1	1.01	0.91	0.79			0.25	52
400	LCA401434	LCA403434	4	1400	IP55	34°	1.29	1.22	1.14	1.05	0.94	0.82			0.25	51
400	LCA401436	LCA403436	4	1400	IP55	36°	1.33	1.26	1.17	1.08	0.97	0.84			0.25	51
400	LCA401438	LCA403438	4	1400	IP55	38°	1.36	1.29	1.2	1.1	0.99	0.84			0.25	50
400	LCA401440	LCA403440	4	1400	IP55	40°	1.39	1.31	1.23	1.13	1.01	0.84			0.37	50

Sound Power Level Spectra dB (ref 10<sup>-12</sup> Watts)

Dia.	1 Phase		3 Phase		Spectrum	dB										
	Stock Ref	Stock Ref	Poles	Rating		63	125	250	500	1k	2k	4k	8k	dBA @3m		
400	LCA401410	LCA403410	4	Inlet/Outlet	72	74	73	69	70	67	63	54	54			
400	LCA401412	LCA403412	4	Inlet/Outlet	72	74	73	69	70	67	63	54	54			
400	LCA401414	LCA403414	4	Inlet/Outlet	72	74	73	69	70	67	63	54	54			
400	LCA401416	LCA403416	4	Inlet/Outlet	72	74	73	69	70	67	63	54	54			
400	LCA401418	LCA403418	4	Inlet/Outlet	72	74	73	69	70	67	63	54	54			
400	LCA401420	LCA403420	4	Inlet/Outlet	72	74	73	69	70	67	63	54	54			
400	LCA401422	LCA403422	4	Inlet/Outlet	66	68	67	63	64	61	57	48	48			
400	LCA401424	LCA403424	4	Inlet/Outlet	66	68	67	63	64	61	57	48	48			
400	LCA401426	LCA403426	4	Inlet/Outlet	68	70	69	65	66	63	59	50	50			
400	LCA401428	LCA403428	4	Inlet/Outlet	69	71	70	66	67	64	60	51	51			
400	LCA401430	LCA403430	4	Inlet/Outlet	70	72	71	67	68	65	61	52	52			
400	LCA401432	LCA403432	4	Inlet/Outlet	70	72	71	67	68	65	61	52	52			
400	LCA401434	LCA403434	4	Inlet/Outlet	69	71	70	66	67	64	60	51	51			
400	LCA401436	LCA403436	4	Inlet/Outlet	69	71	70	66	67	64	60	51	51			
400	LCA401438	LCA403438	4	Inlet/Outlet	68	70	69	65	66	63	59	50	50			
400	LCA401440	LCA403440	4	Inlet/Outlet	68	70	69	65	66	63	59	50	50			

Performance Curve

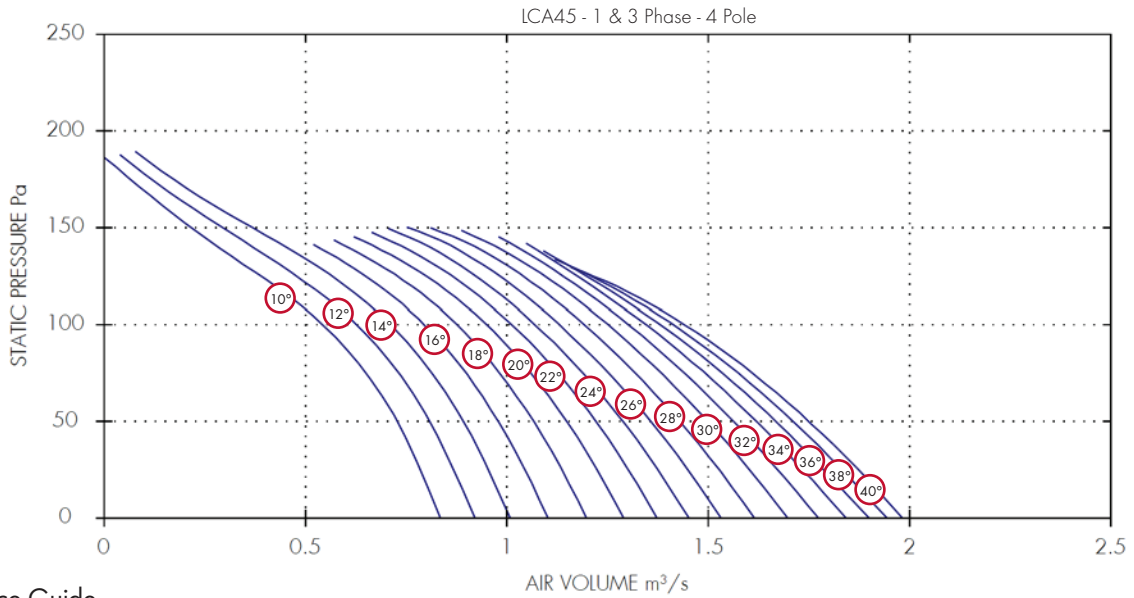

Performance Guide

Dia.	1 Phase		3 Phase		IP	Curve	m³/s at Pa					Motor kW	dBA @3m
	Stock Ref	Stock Ref	Poles	rpm			Rating	0	40	80	120		
450	ICA451410	ICA453410	4	1400	IP55	10°	0.83	0.75	0.63	0.42	0.15	0.25	59
450	ICA451412	ICA453412	4	1400	IP55	12°	0.92	0.83	0.71	0.51	0.22	0.25	59
450	ICA451414	ICA453414	4	1400	IP55	14°	1.01	0.92	0.8	0.6	0.28	0.25	59
450	ICA451416	ICA453416	4	1400	IP55	16°	1.1	1.01	0.88	0.68		0.25	59
450	ICA451418	ICA453418	4	1400	IP55	18°	1.2	1.1	0.96	0.76		0.25	54
450	ICA451420	ICA453420	4	1400	IP55	20°	1.29	1.18	1.04	0.83		0.25	55
450	ICA451422	ICA453422	4	1400	IP55	22°	1.37	1.25	1.11	0.9		0.25	54
450	ICA451424	ICA453424	4	1400	IP55	24°	1.45	1.32	1.17	0.96		0.25	54
450	ICA451426	ICA453426	4	1400	IP55	26°	1.53	1.4	1.23	1.01		0.37	54
450	ICA451428	ICA453428	4	1400	IP55	28°	1.61	1.47	1.29	1.07		0.37	54
450	ICA451430	ICA453430	4	1400	IP55	30°	1.7	1.54	1.36	1.13		0.37	54
450	ICA451432	ICA453432	4	1400	IP55	32°	1.77	1.61	1.41	1.17		0.37	54
450	ICA451434	ICA453434	4	1400	IP55	34°	1.84	1.67	1.46	1.21		0.55	54
450	ICA451436	ICA453436	4	1400	IP55	36°	1.9	1.72	1.51	1.24		0.55	54
450	ICA451438	ICA453438	4	1400	IP55	38°	1.94	1.76	1.54	1.25		0.55	54
450	ICA451440	ICA453440	4	1400	IP55	40°	1.98	1.8	1.58	1.27		0.55	54

Sound Power Level Spectra dB (ref 10<sup>-12</sup> Watts)

Dia.	1 Phase		3 Phase		Spectrum	dB							dBA @3m	
	Stock Ref	Stock Ref	Poles	Rating		63	125	250	500	1k	2k	4k		8k
450	ICA451410	ICA453410	4	IP55	Inlet/Outlet	77	79	78	74	75	72	68	59	59
450	ICA451412	ICA453412	4	IP55	Inlet/Outlet	77	79	78	74	75	72	68	59	59
450	ICA451414	ICA453414	4	IP55	Inlet/Outlet	77	79	78	74	75	72	68	59	59
450	ICA451416	ICA453416	4	IP55	Inlet/Outlet	77	79	78	74	75	72	68	59	59
450	ICA451418	ICA453418	4	IP55	Inlet/Outlet	72	74	73	69	70	67	63	54	54
450	ICA451420	ICA453420	4	IP55	Inlet/Outlet	73	75	74	70	71	68	64	55	55
450	ICA451422	ICA453422	4	IP55	Inlet/Outlet	72	74	73	69	70	67	63	54	54
450	ICA451424	ICA453424	4	IP55	Inlet/Outlet	72	74	73	69	70	67	63	54	54
450	ICA451426	ICA453426	4	IP55	Inlet/Outlet	72	74	73	69	70	67	63	54	54
450	ICA451428	ICA453428	4	IP55	Inlet/Outlet	72	74	73	69	70	67	63	54	54
450	ICA451430	ICA453430	4	IP55	Inlet/Outlet	72	74	73	69	70	67	63	54	54
450	ICA451432	ICA453432	4	IP55	Inlet/Outlet	72	74	73	69	70	67	63	54	54
450	ICA451434	ICA453434	4	IP55	Inlet/Outlet	72	74	73	69	70	67	63	54	54
450	ICA451436	ICA453436	4	IP55	Inlet/Outlet	72	74	73	69	70	67	63	54	54
450	ICA451438	ICA453438	4	IP55	Inlet/Outlet	72	74	73	69	70	67	63	54	54
450	ICA451440	ICA453440	4	IP55	Inlet/Outlet	72	74	73	69	70	67	63	54	54

## Performance Curve

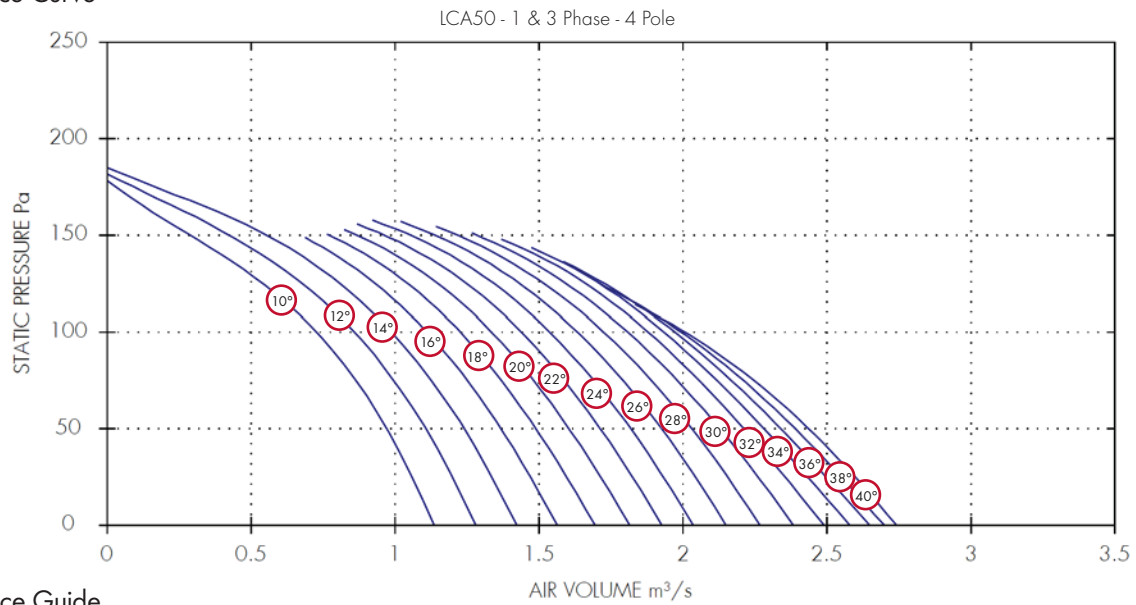

## Performance Guide

Dia.	1 Phase		3 Phase		IP	Curve	m³/s at Pa					Motor kW	dBA @3m
	Stock Ref	Stock Ref	Poles	rpm			Rating	Ref	0	40	80		
500	LCA501410	LCA503410	4	1400	IP55	10°	1.14	1.01	0.84	0.58	0.18	0.25	58
500	LCA501412	LCA503412	4	1400	IP55	12°	1.28	1.15	0.97	0.72	0.3	0.25	58
500	LCA501414	LCA503414	4	1400	IP55	14°	1.42	1.28	1.1	0.85	0.42	0.25	58
500	LCA501416	LCA503416	4	1400	IP55	16°	1.56	1.41	1.22	0.97		0.25	58
500	LCA501418	LCA503418	4	1400	IP55	18°	1.69	1.53	1.34	1.09		0.25	58
500	LCA501420	LCA503420	4	1400	IP55	20°	1.82	1.65	1.45	1.19		0.37	58
500	LCA501422	LCA503422	4	1400	IP55	22°	1.93	1.76	1.56	1.29		0.37	58
500	LCA501424	LCA503424	4	1400	IP55	24°	2.04	1.87	1.66	1.39		0.37	58
500	LCA501426	LCA503426	4	1400	IP55	26°	2.15	1.97	1.76	1.48		0.37	60
500	LCA501428	LCA503428	4	1400	IP55	28°	2.27	2.08	1.86	1.56		0.55	60
500	LCA501430	LCA503430	4	1400	IP55	30°	2.38	2.18	1.95	1.64		0.55	61
500	LCA501432	LCA503432	4	1400	IP55	32°	2.49	2.27	2.02	1.71		0.55	61
500	LCA501434	LCA503434	4	1400	IP55	34°	2.58	2.34	2.08	1.76		0.55	61
500	LCA501436	LCA503436	4	1400	IP55	36°	2.65	2.4	2.13	1.78		0.75	61
500	LCA501438	LCA503438	4	1400	IP55	38°	2.7	2.46	2.17	1.77		0.75	61
500	LCA501440	LCA503440	4	1400	IP55	40°	2.74	2.5	2.2			0.75	61

## Sound Power Level Spectra dB (ref 10<sup>-12</sup> Watts)

Dia.	1 Phase		3 Phase		Spectrum	dB										
	Stock Ref	Stock Ref	Poles	Rating		63	125	250	500	1k	2k	4k	8k	dBA @3m		
500	LCA501410	LCA503410	4	IP55	Inlet/Outlet	76	78	74	75	74	71	68	58	58		
500	LCA501412	LCA503412	4	IP55	Inlet/Outlet	76	78	74	75	74	71	68	58	58		
500	LCA501414	LCA503414	4	IP55	Inlet/Outlet	76	78	74	75	74	71	68	58	58		
500	LCA501416	LCA503416	4	IP55	Inlet/Outlet	76	78	74	75	74	71	68	58	58		
500	LCA501418	LCA503418	4	IP55	Inlet/Outlet	76	78	74	75	74	71	68	58	58		
500	LCA501420	LCA503420	4	IP55	Inlet/Outlet	76	78	74	75	74	71	68	58	58		
500	LCA501422	LCA503422	4	IP55	Inlet/Outlet	76	78	74	75	74	71	68	58	58		
500	LCA501424	LCA503424	4	IP55	Inlet/Outlet	76	78	74	75	74	71	68	58	58		
500	LCA501426	LCA503426	4	IP55	Inlet/Outlet	78	80	76	77	76	73	70	60	60		
500	LCA501428	LCA503428	4	IP55	Inlet/Outlet	78	80	76	77	76	73	70	60	60		
500	LCA501430	LCA503430	4	IP55	Inlet/Outlet	79	81	77	78	77	74	71	61	61		
500	LCA501432	LCA503432	4	IP55	Inlet/Outlet	79	81	77	78	77	74	71	61	61		
500	LCA501434	LCA503434	4	IP55	Inlet/Outlet	79	81	77	78	77	74	71	61	61		
500	LCA501436	LCA503436	4	IP55	Inlet/Outlet	79	81	77	78	77	74	71	61	61		
500	LCA501438	LCA503438	4	IP55	Inlet/Outlet	79	81	77	78	77	74	71	61	61		
500	LCA501440	LCA503440	4	IP55	Inlet/Outlet	79	81	77	78	77	74	71	61	61		

Performance Curve

LCA56 - 1 & 3 Phase - 4 Pole

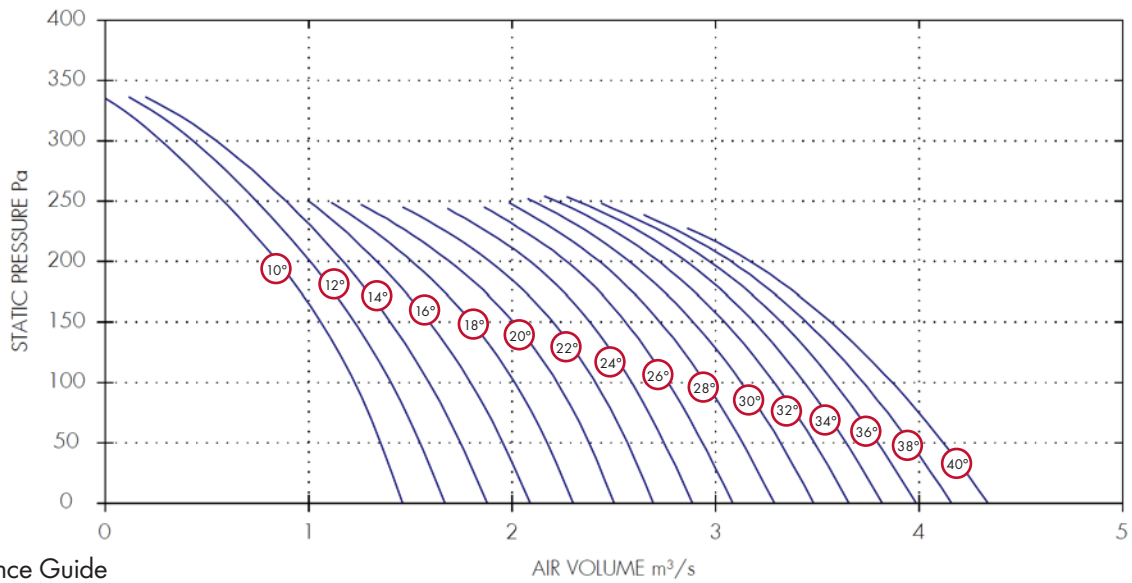

Performance Guide

Dia.	1 Phase		3 Phase		IP	Curve	m³/s at Pa							Motor kW	dBA @3m
	Stock Ref	Stock Ref	Poles	rpm			Rating	Ref	0	50	100	150	200		
560	LCA561410	LCA563410	4	1400	IP55	10°	1.46	1.36	1.23	1.06	0.85	0.58	0.28	0.55	64
560	LCA561412	LCA563412	4	1400	IP55	12°	1.67	1.55	1.41	1.23	1.01	0.74	0.43	0.55	64
560	LCA561414	LCA563414	4	1400	IP55	14°	1.88	1.75	1.59	1.4	1.17	0.89	0.55	0.55	64
560	LCA561416	LCA563416	4	1400	IP55	16°	2.09	1.96	1.8	1.59	1.34			0.55	64
560	LCA561418	LCA563418	4	1400	IP55	18°	2.3	2.17	2.01	1.8	1.51			0.75	64
560	LCA561420	LCA563420	4	1400	IP55	20°	2.5	2.38	2.22	2.01	1.69			0.75	64
560	LCA561422	LCA563422	4	1400	IP55	22°	2.7	2.57	2.41	2.2	1.89			0.75	64
560	LCA561424	LCA563424	4	1400	IP55	24°	2.89	2.75	2.59	2.38	2.09			1.1	64
560	LCA561426	LCA563426	4	1400	IP55	26°	3.08	2.94	2.77	2.56	2.27			1.1	64
560	LCA561428	LCA563428	4	1400	IP55	28°	3.29	3.13	2.95	2.73	2.43			1.1	64
560	LCA561430	LCA563430	4	1400	IP55	30°	3.48	3.32	3.13	2.89	2.58	2.1		1.1	64
560	LCA561432	LCA563432	4	1400	IP55	32°	3.66	3.49	3.29	3.04	2.72	2.21		1.5	64
560	LCA561434	LCA563434	4	1400	IP55	34°	3.82	3.64	3.44	3.19	2.85	2.32		1.5	64
560	LCA561436	LCA563436	4	1400	IP55	36°	3.99	3.8	3.58	3.32	2.97			1.5	64
560	-	LCA563438	4	1400	IP55	38°	4.16	3.96	3.73	3.45	3.08			2.2	64
560	-	LCA563440	4	1400	IP55	40°	4.34	4.12	3.87	3.57	3.17			2.2	64

Sound Power Level Spectra dB (ref 10<sup>-12</sup> Watts)

Dia.	1 Phase		3 Phase		Spectrum	dB											
	Stock Ref	Stock Ref	Poles	rpm		63	125	250	500	1k	2k	4k	8k	dBA @3m			
560	LCA561410	LCA563410	4	1400	Inlet/Outlet	75	75	80	81	81	77	74	64	64			
560	LCA561412	LCA563412	4	1400	Inlet/Outlet	75	75	80	81	81	77	74	64	64			
560	LCA561414	LCA563414	4	1400	Inlet/Outlet	75	75	80	81	81	77	74	64	64			
560	LCA561416	LCA563416	4	1400	Inlet/Outlet	75	75	80	81	81	77	74	64	64			
560	LCA561418	LCA563418	4	1400	Inlet/Outlet	75	75	80	81	81	77	74	64	64			
560	LCA561420	LCA563420	4	1400	Inlet/Outlet	75	75	80	81	81	77	74	64	64			
560	LCA561422	LCA563422	4	1400	Inlet/Outlet	75	75	80	81	81	77	74	64	64			
560	LCA561424	LCA563424	4	1400	Inlet/Outlet	75	75	80	81	81	77	74	64	64			
560	LCA561426	LCA563426	4	1400	Inlet/Outlet	75	75	80	81	81	77	74	64	64			
560	LCA561428	LCA563428	4	1400	Inlet/Outlet	75	75	80	81	81	77	74	64	64			
560	LCA561430	LCA563430	4	1400	Inlet/Outlet	75	75	80	81	81	77	74	64	64			
560	LCA561432	LCA563432	4	1400	Inlet/Outlet	75	75	80	81	81	77	74	64	64			
560	LCA561434	LCA563434	4	1400	Inlet/Outlet	75	75	80	81	81	77	74	64	64			
560	LCA561436	LCA563436	4	1400	Inlet/Outlet	75	75	80	81	81	77	74	64	64			
560	-	LCA563438	4	1400	Inlet/Outlet	75	75	80	81	81	77	74	64	64			
560	-	LCA563440	4	1400	Inlet/Outlet	75	75	80	81	81	77	74	64	64			



Performance Curve

LCA63 - 1 & 3 Phase - 4 Pole

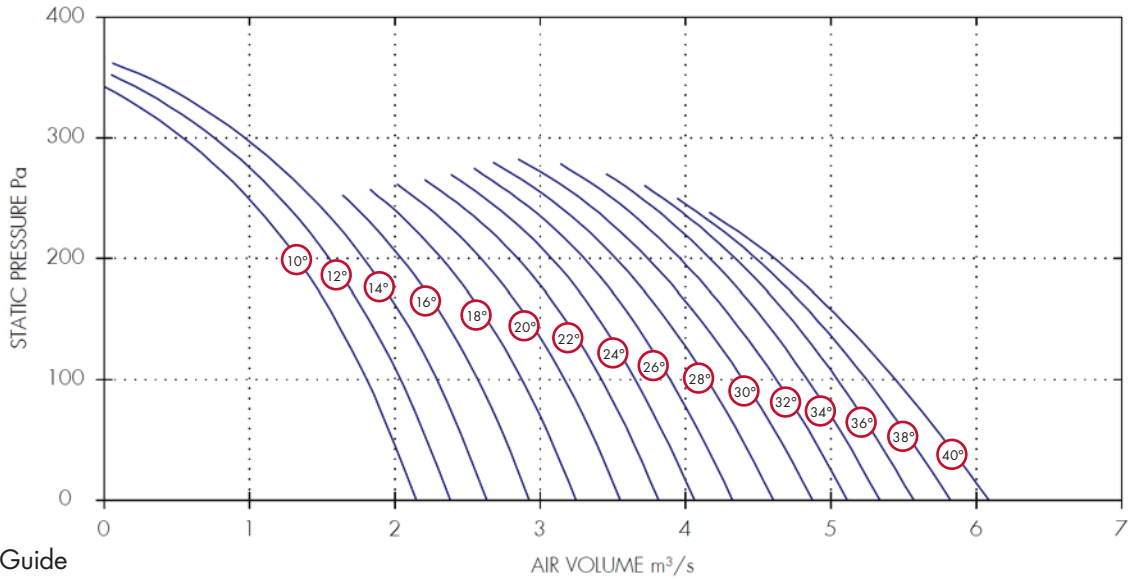

Performance Guide

Dia.	1 Phase		3 Phase		IP	Curve	m³/s at Pa						Motor kW	dBA @3m	
	Stock Ref	Stock Ref	Poles	rpm			Rating	Ref	0	50	100	150			200
630	LCA631410	LCA633410	4	1400	IP55	10°	2.15	1.99	1.81	1.59	1.33	0.99	0.54	0.55	64
630	LCA631412	LCA633412	4	1400	IP55	12°	2.38	2.22	2.04	1.82	1.55	1.21	0.76	0.75	64
630	LCA631414	LCA633414	4	1400	IP55	14°	2.64	2.47	2.29	2.06	1.79	1.43	0.97	0.75	64
630	LCA631416	LCA633416	4	1400	IP55	16°	2.93	2.76	2.57	2.34	2.05	1.66	1.1	0.75	64
630	LCA631418	LCA633418	4	1400	IP55	18°	3.24	3.08	2.88	2.63	2.32	1.9	1.1	0.75	64
630	LCA631420	LCA633420	4	1400	IP55	20°	3.55	3.37	3.17	2.92	2.59	2.14	1.1	0.75	64
630	LCA631422	LCA633422	4	1400	IP55	22°	3.82	3.63	3.42	3.17	2.85	2.38	1.5	0.75	65
630	LCA631424	LCA633424	4	1400	IP55	24°	4.06	3.87	3.66	3.4	3.08	2.62	1.5	0.75	65
630	LCA631426	LCA633426	4	1400	IP55	26°	4.32	4.12	3.9	3.63	3.3	2.84	1.5	0.75	65
630	-	LCA633428	4	1400	IP55	28°	4.61	4.39	4.15	3.87	3.52	3.06	2.2	0.75	65
630	-	LCA633430	4	1400	IP55	30°	4.88	4.65	4.4	4.1	3.74	3.27	2.2	0.75	65
630	-	LCA633432	4	1400	IP55	32°	5.11	4.89	4.63	4.32	3.96	3.5	2.2	0.75	65
630	-	LCA633434	4	1400	IP55	34°	5.34	5.1	4.84	4.54	4.17	3.7	2.2	0.75	65
630	-	LCA633436	4	1400	IP55	36°	5.57	5.32	5.04	4.73	4.34	3.84	3	0.75	65
630	-	LCA633438	4	1400	IP55	38°	5.82	5.55	5.25	4.9	4.48	3.84	3	0.75	65
630	-	LCA633440	4	1400	IP55	40°	6.09	5.78	5.44	5.06	4.61	3.84	3	0.75	65

Sound Power Level Spectra dB (ref 10<sup>-12</sup> Watts)

Dia.	1 Phase		3 Phase		Spectrum	dB							dBA @3m	
	Stock Ref	Stock Ref	Poles	rpm		63	125	250	500	1k	2k	4k		8k
630	LCA631410	LCA633410	4	1400	Inlet/Outlet	75	71	79	82	81	77	74	66	64
630	LCA631412	LCA633412	4	1400	Inlet/Outlet	75	71	79	82	81	77	74	66	64
630	LCA631414	LCA633414	4	1400	Inlet/Outlet	75	71	79	82	81	77	74	66	64
630	LCA631416	LCA633416	4	1400	Inlet/Outlet	75	71	79	82	81	77	74	66	64
630	LCA631418	LCA633418	4	1400	Inlet/Outlet	75	71	79	82	81	77	74	66	64
630	LCA631420	LCA633420	4	1400	Inlet/Outlet	75	71	79	82	81	77	74	66	64
630	LCA631422	LCA633422	4	1400	Inlet/Outlet	76	72	80	83	82	78	75	67	65
630	LCA631424	LCA633424	4	1400	Inlet/Outlet	76	72	80	83	82	78	75	67	65
630	LCA631426	LCA633426	4	1400	Inlet/Outlet	76	72	80	83	82	78	75	67	65
630	-	LCA633428	4	1400	Inlet/Outlet	76	72	80	83	82	78	75	67	65
630	-	LCA633430	4	1400	Inlet/Outlet	76	72	80	83	82	78	75	67	65
630	-	LCA633432	4	1400	Inlet/Outlet	76	72	80	83	82	78	75	67	65
630	-	LCA633434	4	1400	Inlet/Outlet	76	72	80	83	82	78	75	67	65
630	-	LCA633436	4	1400	Inlet/Outlet	76	72	80	83	82	78	75	67	65
630	-	LCA633438	4	1400	Inlet/Outlet	76	72	80	83	82	78	75	67	65
630	-	LCA633440	4	1400	Inlet/Outlet	76	72	80	83	82	78	75	67	65

Performance Curve

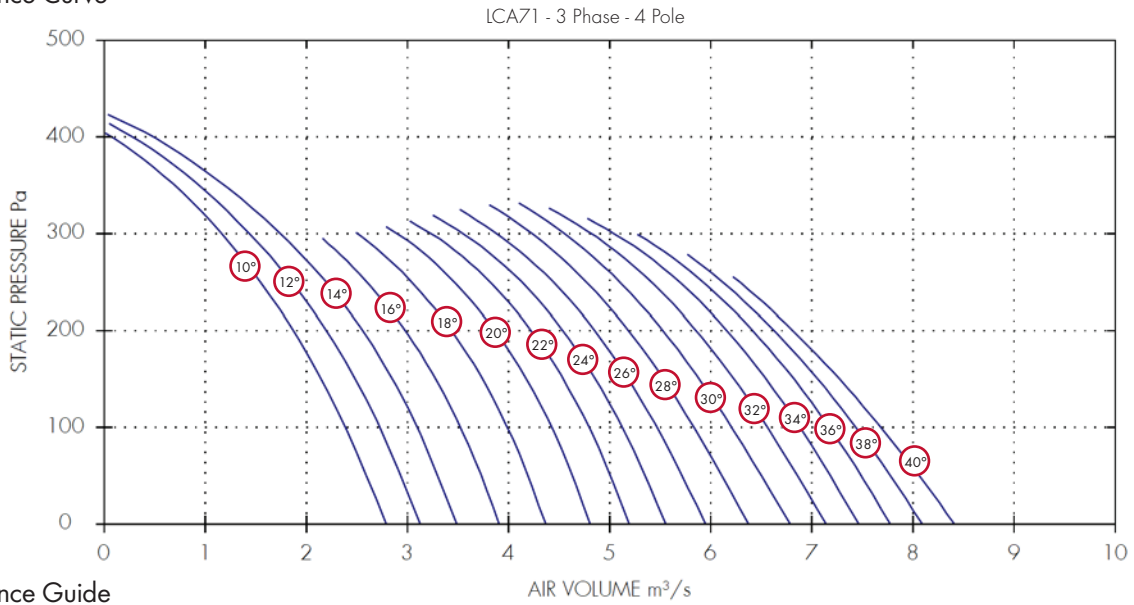

Performance Guide

Dia.	3 Phase		rpm	IP Rating	Curve Ref	m³/s at Pa					Motor kW	dBA @3m
	Stock Ref	Poles				0	100	200	300	400		
710	LCA713410	4	1420	IP55	10°	2.79	2.39	1.87	1.16	0.07	0.75	74
710	LCA713412	4	1420	IP55	12°	3.12	2.73	2.2	1.44	0.28	1.1	74
710	LCA713414	4	1420	IP55	14°	3.49	3.1	2.56	1.74	0.48	1.1	74
710	LCA713416	4	1420	IP55	16°	3.91	3.53	2.98			1.5	74
710	LCA713418	4	1420	IP55	18°	4.37	3.99	3.44	2.5		1.5	74
710	LCA713420	4	1420	IP55	20°	4.81	4.43	3.87	2.89		2.2	71
710	LCA713422	4	1420	IP55	22°	5.19	4.8	4.23	3.23		2.2	71
710	LCA713424	4	1420	IP55	24°	5.56	5.13	4.54	3.55		2.2	71
710	LCA713426	4	1420	IP55	26°	5.95	5.47	4.85	3.88		3	71
710	LCA713428	4	1420	IP55	28°	6.37	5.84	5.19	4.23		3	71
710	LCA713430	4	1420	IP55	30°	6.78	6.21	5.53	4.55		3	71
710	LCA713432	4	1420	IP55	32°	7.14	6.56	5.86	4.82		4	71
710	LCA713434	4	1420	IP55	34°	7.46	6.88	6.16	5.04		4	71
710	LCA713436	4	1420	IP55	36°	7.77	7.17	6.42			4	71
710	LCA713438	4	1420	IP55	38°	8.09	7.44	6.63			5.5	71
710	LCA713440	4	1420	IP55	40°	8.41	7.68	6.81			5.5	71

Sound Power Level Spectra dB (ref 10<sup>-12</sup> Watts)

Dia.	3 Phase		Spectrum	dB							dBA @3m	
	Stock Ref	Poles		63	125	250	500	1k	2k	4k		8k
710	LCA713410	4	Inlet/Outlet	89	84	92	92	90	85	82	75	74
710	LCA713412	4	Inlet/Outlet	89	84	92	92	90	85	82	75	74
710	LCA713414	4	Inlet/Outlet	89	84	92	92	90	85	82	75	74
710	LCA713416	4	Inlet/Outlet	89	84	92	92	90	85	82	75	74
710	LCA713418	4	Inlet/Outlet	89	84	92	92	90	85	82	75	74
710	LCA713420	4	Inlet/Outlet	86	81	89	89	87	82	79	72	71
710	LCA713422	4	Inlet/Outlet	86	81	89	89	87	82	79	72	71
710	LCA713424	4	Inlet/Outlet	86	81	89	89	87	82	79	72	71
710	LCA713426	4	Inlet/Outlet	86	81	89	89	87	82	79	72	71
710	LCA713428	4	Inlet/Outlet	86	81	89	89	87	82	79	72	71
710	LCA713430	4	Inlet/Outlet	86	81	89	89	87	82	79	72	71
710	LCA713432	4	Inlet/Outlet	86	81	89	89	87	82	79	72	71
710	LCA713434	4	Inlet/Outlet	86	81	89	89	87	82	79	72	71
710	LCA713436	4	Inlet/Outlet	86	81	89	89	87	82	79	72	71
710	LCA713438	4	Inlet/Outlet	86	81	89	89	87	82	79	72	71
710	LCA713440	4	Inlet/Outlet	86	81	89	89	87	82	79	72	71

Performance Curve

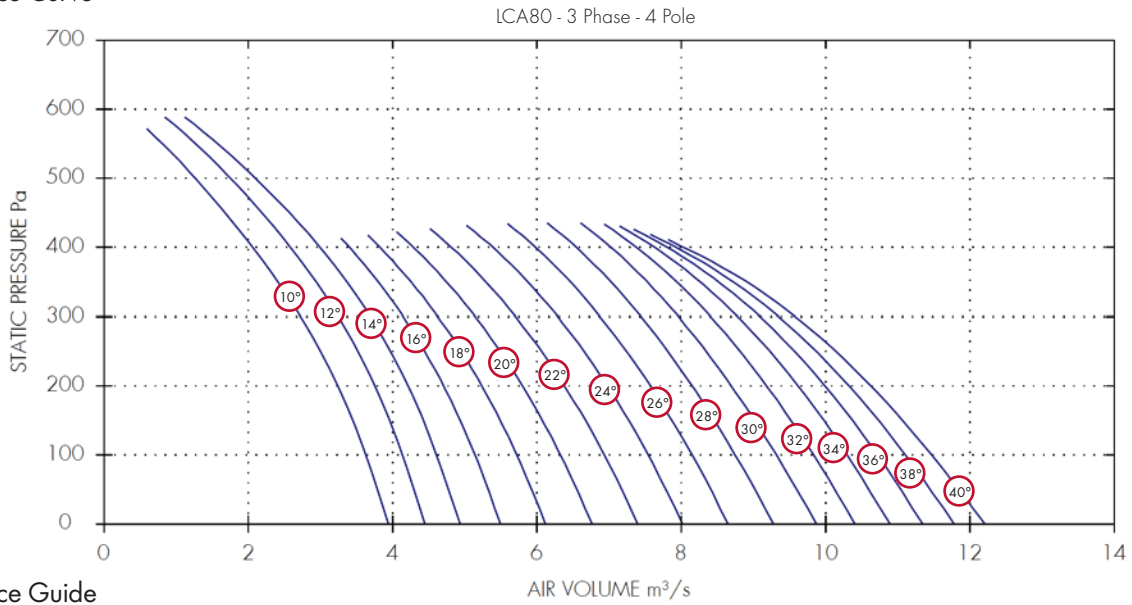

Performance Guide

Dia.	3 Phase		rpm	IP Rating	Curve Ref	m³/s at Pa					Motor kW	dBA @3m	
	Stock Ref	Poles				0	100	200	300	400			500
800	LCA803410	4	1420	IP55	10°	3.94	3.63	3.24	2.73	2.06	1.27	2.2	80
800	LCA803412	4	1440	IP55	12°	4.45	4.14	3.76	3.25	2.58	1.75	2.2	80
800	LCA803414	4	1440	IP55	14°	4.94	4.61	4.21	3.69	2.99	2.1	3	80
800	LCA803416	4	1440	IP55	16°	5.49	5.14	4.71	4.15	3.4		3	80
800	LCA803418	4	1440	IP55	18°	6.12	5.72	5.24	4.63	3.82		3	80
800	LCA803420	4	1440	IP55	20°	6.77	6.33	5.8	5.14	4.29		3	77
800	LCA803422	4	1440	IP55	22°	7.4	6.94	6.38	5.7	4.82		4	78
800	LCA803424	4	1440	IP55	24°	8.02	7.54	6.98	6.29	5.39		4	78
800	LCA803426	4	1440	IP55	26°	8.65	8.15	7.57	6.88	5.98		5.5	78
800	LCA803428	4	1440	IP55	28°	9.28	8.75	8.15	7.44	6.55		5.5	79
800	LCA803430	4	1440	IP55	30°	9.88	9.32	8.69	7.96	7.03		7.5	79
800	LCA803432	4	1440	IP55	32°	10.41	9.84	9.19	8.41	7.38		7.5	79
800	LCA803434	4	1440	IP55	34°	10.89	10.3	9.62	8.78	7.63		7.5	79
800	LCA803436	4	1440	IP55	36°	11.34	10.72	10	9.09	7.8		11	79
800	LCA803438	4	1440	IP55	38°	11.78	11.11	10.33	9.35	7.93		11	79
800	LCA803440	4	1440	IP55	40°	12.21	11.47	10.63	9.58	8.04		11	79

Sound Power Level Spectra dB (ref 10<sup>-12</sup> Watts)

Dia.	3 Phase		Spectrum	dB								dBA @3m
	Stock Ref	Poles		63	125	250	500	1k	2k	4k	8k	
800	LCA803410	4	Inlet/Outlet	93	87	93	98	96	93	88	80	80
800	LCA803412	4	Inlet/Outlet	93	87	93	98	96	93	88	80	80
800	LCA803414	4	Inlet/Outlet	93	87	93	98	96	93	88	80	80
800	LCA803416	4	Inlet/Outlet	93	87	93	98	96	93	88	80	80
800	LCA803418	4	Inlet/Outlet	93	87	93	98	96	93	88	80	80
800	LCA803420	4	Inlet/Outlet	90	84	90	95	93	90	85	77	77
800	LCA803422	4	Inlet/Outlet	91	85	91	96	94	91	86	78	78
800	LCA803424	4	Inlet/Outlet	91	85	91	96	94	91	86	78	78
800	LCA803426	4	Inlet/Outlet	91	85	91	96	94	91	86	78	78
800	LCA803428	4	Inlet/Outlet	92	86	92	97	95	92	87	79	79
800	LCA803430	4	Inlet/Outlet	92	86	92	97	95	92	87	79	79
800	LCA803432	4	Inlet/Outlet	92	86	92	97	95	92	87	79	79
800	LCA803434	4	Inlet/Outlet	92	86	92	97	95	92	87	79	79
800	LCA803436	4	Inlet/Outlet	92	86	92	97	95	92	87	79	79
800	LCA803438	4	Inlet/Outlet	92	86	92	97	95	92	87	79	79
800	LCA803440	4	Inlet/Outlet	92	86	92	97	95	92	87	79	79

Performance Curve

LCA90 - 3 Phase - 4 Pole

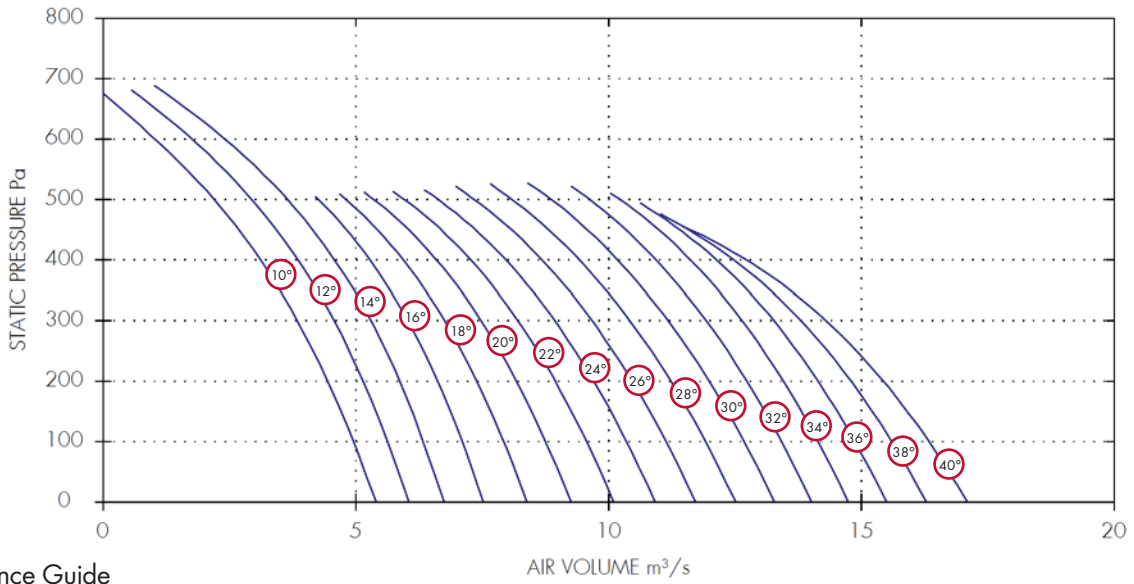

Performance Guide

3 Phase		IP	Curve	m³/s at Pa								Motor	dBa	
Dia.	Stock Ref			Poles	rpm	Rating	Ref	0	100	200	300			400
900	LCA903410	4	1440	IP55	10°	5.4	4.95	4.45	3.84	3.11	2.19	1.02	3	79
900	LCA903412	4	1440	IP55	12°	6.05	5.63	5.15	4.57	3.85	2.94	1.75	4	80
900	LCA903414	4	1440	IP55	14°	6.74	6.34	5.87	5.3	4.58	3.64	2.41	4	80
900	LCA903416	4	1440	IP55	16°	7.52	7.11	6.62	6.03	5.27	4.26		4	80
900	LCA903418	4	1440	IP55	18°	8.38	7.93	7.4	6.75	5.94	4.8		5.5	81
900	LCA903420	4	1440	IP55	20°	9.26	8.76	8.18	7.48	6.6	5.35		5.5	81
900	LCA903422	4	1440	IP55	22°	10.1	9.57	8.95	8.21	7.27	5.96		7.5	81
900	LCA903424	4	1440	IP55	24°	10.92	10.35	9.71	8.94	7.97	6.62		7.5	81
900	LCA903426	4	1440	IP55	26°	11.72	11.14	10.47	9.67	8.68	7.34		7.5	82
900	LCA903428	4	1440	IP55	28°	12.51	11.92	11.23	10.42	9.42	8.09		11	82
900	LCA903430	4	1440	IP55	30°	13.28	12.69	11.99	11.18	10.17	8.86		11	82
900	LCA903432	4	1440	IP55	32°	14.02	13.42	12.74	11.93	10.94	9.62		11	82
900	LCA903434	4	1440	IP55	34°	14.74	14.15	13.46	12.64	11.62	10.22		15	82
900	LCA903436	4	1440	IP55	36°	15.5	14.87	14.14	13.27	12.14			15	82
900	LCA903438	4	1440	IP55	38°	16.29	15.6	14.8	13.81	12.47			15	82
900	LCA903440	4	1440	IP55	40°	17.1	16.34	15.44	14.3	12.72			15	82

Sound Power Level Spectra dB (ref 10<sup>-12</sup> Watts)

Dia.	3 Phase Stock Ref	Poles	Spectrum									dBa @3m
				63	125	250	500	1k	2k	4k	8k	
900	LCA903410	4	Inlet/Outlet	89	83	91	97	95	92	87	79	79
900	LCA903412	4	Inlet/Outlet	90	84	92	98	96	93	88	80	80
900	LCA903414	4	Inlet/Outlet	90	84	92	98	96	93	88	80	80
900	LCA903416	4	Inlet/Outlet	90	84	92	98	96	93	88	80	80
900	LCA903418	4	Inlet/Outlet	91	85	93	99	97	94	89	81	81
900	LCA903420	4	Inlet/Outlet	91	85	93	99	97	94	89	81	81
900	LCA903422	4	Inlet/Outlet	91	85	93	99	97	94	89	81	81
900	LCA903424	4	Inlet/Outlet	91	85	93	99	97	94	89	81	81
900	LCA903426	4	Inlet/Outlet	92	86	94	100	98	95	90	82	82
900	LCA903428	4	Inlet/Outlet	92	86	94	100	98	95	90	82	82
900	LCA903430	4	Inlet/Outlet	92	86	94	100	98	95	90	82	82
900	LCA903432	4	Inlet/Outlet	92	86	94	100	98	95	90	82	82
900	LCA903434	4	Inlet/Outlet	92	86	94	100	98	95	90	82	82
900	LCA903436	4	Inlet/Outlet	92	86	94	100	98	95	90	82	82
900	LCA903438	4	Inlet/Outlet	92	86	94	100	98	95	90	82	82
900	LCA903440	4	Inlet/Outlet	92	86	94	100	98	95	90	82	82

Performance Curve

LCA100 - 3 Phase - 4 Pole

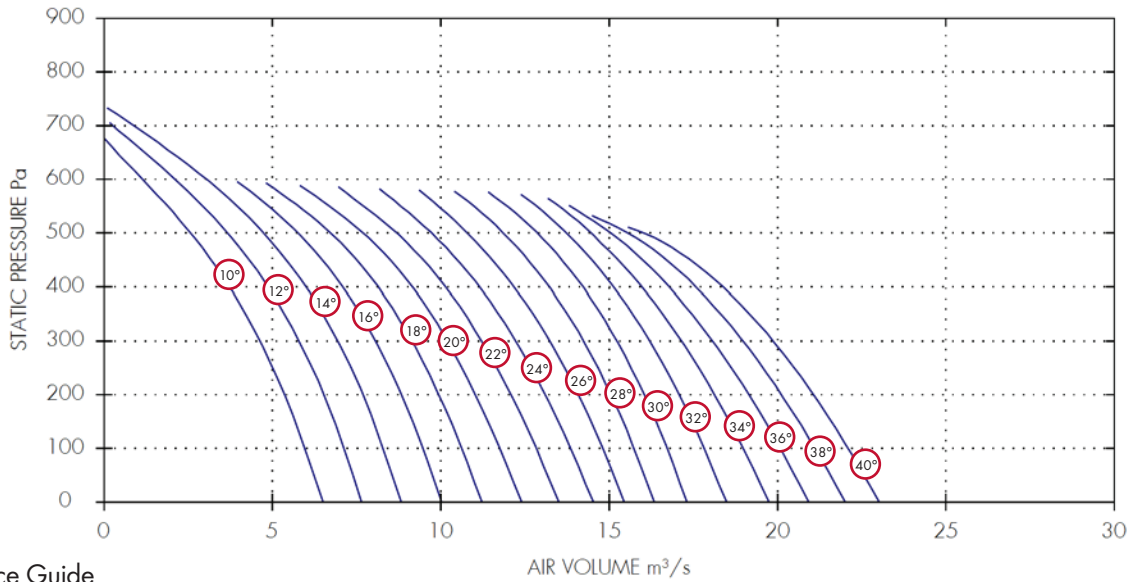

Performance Guide

3 Phase		Poles	rpm	IP Rating	Curve Ref	m³/s at Pa					Motor kW	dBA @3m
Dia.	Stock Ref					0	150	300	450	600		
1000	LCA1003410	4	1440	IP55	10°	6.5	5.68	4.63	3.18	1.14	4	89
1000	LCA1003412	4	1440	IP55	12°	7.66	6.85	5.79	4.31	2.11	4	89
1000	LCA1003414	4	1440	IP55	14°	8.83	8.01	6.94	5.41	3.04	5.5	89
1000	LCA1003416	4	1440	IP55	16°	10.02	9.17	8.06	6.48		5.5	89
1000	LCA1003418	4	1440	IP55	18°	11.23	10.3	9.15	7.51		7.5	89
1000	LCA1003420	4	1440	IP55	20°	12.4	11.41	10.2	8.5		7.5	89
1000	LCA1003422	4	1440	IP55	22°	13.51	12.47	11.22	9.49		7.5	89
1000	LCA1003424	4	1440	IP55	24°	14.53	13.5	12.23	10.49		11	89
1000	LCA1003426	4	1440	IP55	26°	15.45	14.47	13.23	11.53		11	89
1000	LCA1003428	4	1440	IP55	28°	16.33	15.41	14.24	12.6		15	89
1000	LCA1003430	4	1440	IP55	30°	17.31	16.4	15.24	13.6		15	89
1000	LCA1003432	4	1440	IP55	32°	18.48	17.47	16.21	14.48		15	89
1000	LCA1003434	4	1440	IP55	34°	19.74	18.58	17.15	15.26		18.5	89
1000	LCA1003436	4	1440	IP55	36°	20.93	19.64	18.07	16		18.5	89
1000	LCA1003438	4	1440	IP55	38°	22.01	20.64	18.98	16.71		18.5	89
1000	LCA1003440	4	1440	IP55	40°	23.03	21.6	19.87	17.41		22	89

Sound Power Level Spectra dB (ref 10<sup>-12</sup> Watts)

Dia.	3 Phase Stock Ref	Poles	Spectrum	dB								dBA @3m
				63	125	250	500	1k	2k	4k	8k	
1000	LCA1003410	4	Inlet/Outlet	99	94	101	106	106	102	97	89	89
1000	LCA1003412	4	Inlet/Outlet	99	94	101	106	106	102	97	89	89
1000	LCA1003414	4	Inlet/Outlet	99	94	101	106	106	102	97	89	89
1000	LCA1003416	4	Inlet/Outlet	99	94	101	106	106	102	97	89	89
1000	LCA1003418	4	Inlet/Outlet	99	94	101	106	106	102	97	89	89
1000	LCA1003420	4	Inlet/Outlet	99	94	101	106	106	102	97	89	89
1000	LCA1003422	4	Inlet/Outlet	99	94	101	106	106	102	97	89	89
1000	LCA1003424	4	Inlet/Outlet	99	94	101	106	106	102	97	89	89
1000	LCA1003426	4	Inlet/Outlet	99	94	101	106	106	102	97	89	89
1000	LCA1003428	4	Inlet/Outlet	99	94	101	106	106	102	97	89	89
1000	LCA1003430	4	Inlet/Outlet	99	94	101	106	106	102	97	89	89
1000	LCA1003432	4	Inlet/Outlet	99	94	101	106	106	102	97	89	89
1000	LCA1003434	4	Inlet/Outlet	99	94	101	106	106	102	97	89	89
1000	LCA1003436	4	Inlet/Outlet	99	94	101	106	106	102	97	89	89
1000	LCA1003438	4	Inlet/Outlet	99	94	101	106	106	102	97	89	89
1000	LCA1003440	4	Inlet/Outlet	99	94	101	106	106	102	97	89	89

### Performance Curve

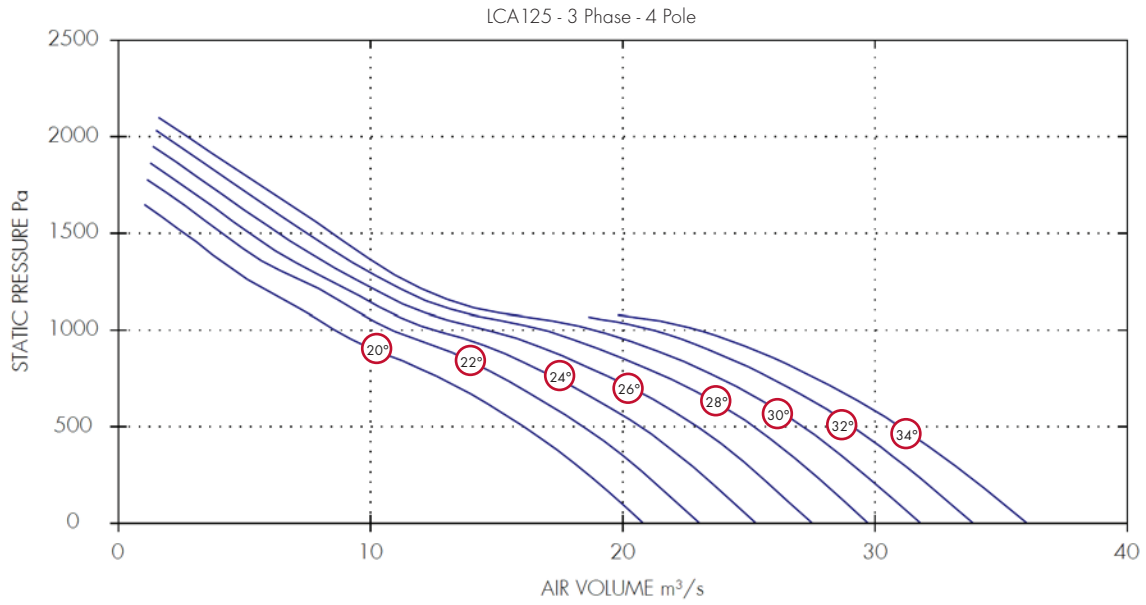

### Performance Guide

Dia.	3 Phase			IP Rating	Curve Ref	m³/s at Pa								Motor kW	dBA @3m	
	Stock Ref	Poles	rpm			0	250	500	750	1000	1250	1500	1750			2000
1250	LCA1253420	4	1475	IP55	20°	20.81	18.64	16.07	12.79	8.59	5.26	2.6			22	83
1250	LCA1253422	4	1475	IP55	22°	23.03	20.92	18.43	15.28	10.86	7.33	4.1	1.46		30	84
1250	LCA1253424	4	1475	IP55	24°	25.27	23.16	20.69	17.37	12.55	8.47	5.18	2.51		30	85
1250	LCA1253426	4	1475	IP55	26°	27.51	25.39	22.96	19.57	14.61	9.54	6.33	3.58		37	86
1250	LCA1253428	4	1475	IP55	28°	29.72	27.6	25.18	21.83	16.82	10.6	7.46	4.64	1.84	37	87
1250	LCA1253430	4	1475	IP55	30°	31.81	29.62	27.15	23.86	18.86	11.45	8.46	5.62	2.71	37	87
1250	LCA1253432	4	1475	IP55	32°	33.89	31.63	29.13	25.88	21.13					45	88
1250	LCA1253434	4	1475	IP55	34°	36.01	33.63	30.98	27.66	22.97					45	88

### Sound Power Level Spectra dB (ref 10<sup>-12</sup> Watts)

Dia.	3 Phase		Spectrum									dBA @3m
	Stock Ref	Poles		63	125	250	500	1k	2k	4k	8k	
1250	LCA1253420	4	Inlet/Outlet	98	105	101	100	98	95	92	89	83
1250	LCA1253422	4	Inlet/Outlet	99	106	102	101	99	96	93	90	84
1250	LCA1253424	4	Inlet/Outlet	100	107	103	102	100	97	94	91	85
1250	LCA1253426	4	Inlet/Outlet	101	108	104	103	101	98	95	92	86
1250	LCA1253428	4	Inlet/Outlet	102	109	105	104	102	99	96	93	87
1250	LCA1253430	4	Inlet/Outlet	102	109	105	104	102	99	96	93	87
1250	LCA1253432	4	Inlet/Outlet	103	110	106	105	103	100	97	94	88
1250	LCA1253434	4	Inlet/Outlet	103	110	106	105	103	100	97	94	88

## Electrical Details

### 1 Phase 2 Pole

Stock Ref	rpm	Pitch Angle	Motor kW	S.C. Amps	F.L.C Amps	Starting Method	Starter Ref	Overload Ref	Transform Controller	*eDemand Controller		
										Voltage Control	1/3 Phase Inverter	3 Phase Inverter
LCA25	2800	25°-40°	0.37	8	2.6	D.O.L.	444744	444702	-	-	-	-
LCA31	2800	10°-24°	0.37	8	2.6	D.O.L.	444744	444702	-	-	-	-
LCA31	2800	26°-32°	0.55	14	3.6	D.O.L.	444744	444703	-	-	-	-
LCA31	2800	34°-38°	0.75	16	4.5	D.O.L.	444744	444703	-	-	-	-
LCA35	2800	10°-12°	0.55	14	3.6	D.O.L.	444744	444703	-	-	-	-
LCA35	2800	22°-26°	0.75	16	4.5	D.O.L.	444744	444703	-	-	-	-
LCA35	2800	28°-34°	1.1	23	6.6	D.O.L.	444744	444704	-	-	-	-
LCA35	2800	36°-38°	1.5	31	8.5	D.O.L.	444744	444705	-	-	-	-
LCA40	2800	10°-12°	0.55	14	3.6	D.O.L.	444744	444703	-	-	-	-
LCA40	2800	14°-18°	0.75	16	4.5	D.O.L.	444744	444704	-	-	-	-
LCA40	2800	20°-24°	1.1	23	6.6	D.O.L.	444744	444704	-	-	-	-
LCA40	2800	26°-32°	1.5	31	8.5	D.O.L.	444744	444705	-	-	-	-

\*1 phase 2 pole is not speed controllable

### 3 Phase 2 Pole

Stock Ref	rpm	Pitch Angle	Motor kW	S.C. Amps	F.L.C Amps	Starting Method	Starter Ref	Overload Ref	Transform Controller	eDemand Controller	
										Voltage Control	3 Phase Inverter
LCA25	2800	25°-40°	0.37	5.82	0.97	D.O.L.	444747	444700	-	-	444172
LCA31	2800	10°-24°	0.37	5.82	0.97	D.O.L.	444747	444700	-	-	444172
LCA31	2800	26°-32°	0.55	8.52	1.42	D.O.L.	444747	444701	-	-	444172
LCA31	2800	34°-38°	0.75	10.62	1.77	D.O.L.	444747	444701	-	-	444172
LCA35	2800	10°-12°	0.37	5.82	0.97	D.O.L.	444747	444700	-	-	444172
LCA35	2800	14°-20°	0.55	8.52	1.42	D.O.L.	444747	444701	-	-	444172
LCA35	2800	22°-26°	0.75	10.62	1.77	D.O.L.	444747	444701	-	-	444172
LCA35	2800	28°-34°	1.1	15.06	2.51	D.O.L.	444747	444702	-	-	444173
LCA35	2800	36°-38°	1.5	19.68	3.28	D.O.L.	444747	444702	-	-	444173
LCA35	2800	40°	2.2	27.66	4.61	D.O.L.	444747	444703	-	-	444174
LCA40	2800	10°-12°	0.55	8.52	1.42	D.O.L.	444747	444701	-	-	444172
LCA40	2800	14°-18°	0.75	10.62	1.77	D.O.L.	444747	444701	-	-	444172
LCA40	2800	20°-26°	1.1	15.06	2.51	D.O.L.	444747	444702	-	-	444173
LCA40	2800	28°-32°	1.5	19.68	3.28	D.O.L.	444747	444702	-	-	444173
LCA40	2800	34°-38°	2.2	27.66	4.61	D.O.L.	444744	444703	-	-	444174
LCA40	2800	40°	3	42.2	6.03	D.O.L.	444747	444704	-	-	444174
LCA45	2880	10°-12°	1.1	15.06	2.51	D.O.L.	444747	444702	-	-	444173
LCA45	2880	14°-18°	1.5	19.68	3.28	D.O.L.	444747	444702	-	-	444173
LCA45	2880	20°-26°	2.2	27.66	4.61	D.O.L.	444747	444703	-	-	444173
LCA45	2880	28°-32°	3	42.2	6.03	D.O.L.	444747	444704	-	-	444174
LCA50	2880	10°-12°	1.5	19.68	3.28	D.O.L.	444747	444702	-	-	444173
LCA50	2880	14°-18°	2.2	27.66	4.61	D.O.L.	444747	444703	-	-	444174
LCA50	2880	20°-24°	3	42.2	6.03	D.O.L.	444747	444704	-	-	444174
LCA50	2880	26°-30°	4	59.1	7.88	D.O.L.	444747	444705	-	-	444175
LCA50	2880	32°-36°	5.5	78.8	10.5	D.O.L.	444748	444706	-	-	444175

## Speed Controllers

Used in conjunction with speed controllable fans Vent-Axia offers a choice of speed controllers, the traditional Five-Step Auto Transformer or the Inverter Speed Controller.

The Five-Step-Auto Transformer provides five stepped speed settings without the electronic motor harmonic noise associated with all electronic or solid state type Speed Controllers.

eDemand Speed Controllers & Inverters see Accessories & Controllers Section.



## Electrical Details

### 3 Phase 2 Pole

Stock Ref	rpm	Pitch Angle	Motor kW	S.C. Amps	F.L.C Amps	Starting Method	Starter Ref	Overload Ref	Transform Controller	eDemand Controller		
										Voltage Control	1/3 Phase Inverter	3 Phase Inverter
LCA50	2880	38°-40°	7.5	106	14.1	D.O.L	444748	444707	-	-	-	444176
LCA56	2880	10°-14°	4	59.1	7.88	D.O.L	444747	444705	-	-	-	444175
LCA56	2880	16°-18°	5.5	78.8	10.5	D.O.L	444748	444706	-	-	-	444175
LCA56	2880	20°-24°	7.5	106	14.1	D.O.L	444748	444707	-	-	-	444176
LCA63	2940	10°-12°	5.5	78.8	10.5	D.O.L	444748	444706	-	-	-	444175
LCA63	2940	14°-16°	7.5	106	14.1	D.O.L	444748	444707	-	-	-	444176
LCA63	2940	18°-22°	11	52.3	20.9	Star Delta	444843	444707	-	-	-	-
LCA63	2940	24°-28°	15	75.3	30.1	Star Delta	-	-	-	-	-	-

### 1 Phase 4 Pole

Stock Ref	rpm	Pitch Angle	Motor kW	S.C. Amps	F.L.C Amps	Starting Method	Starter Ref	Overload Ref	Transform Controller	eDemand Controller		
										Voltage Control	1/3 Phase Inverter	3 Phase Inverter
LCA25	1400	25°-40°	0.25	5	2	D.O.L	444744	444701	10314103	444164	-	-
LCA31	1400	10°-38°	0.25	5	2	D.O.L	444744	444701	10314103	444164	-	-
LCA35	1400	10°-38°	0.25	5	2	D.O.L	444744	444701	10314103	444164	-	-
LCA40	1400	10°-36°	0.25	5	2	D.O.L	444744	444701	10314103	444164	-	-
LCA40	1400	38°-40°	0.37	7	2.9	D.O.L	444744	444702	10314105	444164	-	-
LCA45	1400	10°-24°	0.25	5	2	D.O.L	444744	444701	10314103	444164	-	-
LCA45	1400	26°-32°	0.37	7	2.9	D.O.L	444744	444702	10314105	444164	-	-
LCA45	1400	34°-40°	0.55	11	3.9	D.O.L	444744	444703	10314105	444164	-	-
LCA50	1400	10°-18°	0.25	5	2	D.O.L	444744	444701	10314103	444164	-	-
LCA50	1400	20°-26°	0.37	7	2.9	D.O.L	444744	444702	10314105	444164	-	-
LCA50	1400	28°-34°	0.55	11	3.9	D.O.L	444744	444703	10314105	444164	-	-
LCA50	1400	36°-40°	0.75	15	5.3	D.O.L	444744	444704	10314107	444165	-	-
LCA56	1400	10°-16°	0.55	11	3.9	D.O.L	444744	444703	10314105	444164	-	-
LCA56	1400	18°-22°	0.75	15	5.3	D.O.L	444744	444704	10314107	444165	-	-
LCA56	1400	24°-30°	1.1	22	7	D.O.L	444744	444705	10314120	444165	-	-
LCA56	1400	32°-36°	1.5	32	9.3	D.O.L	444744	444706	10314120	-	-	-
LCA63	1400	10°-12°	0.55	11	3.9	D.O.L	444744	444703	10314105	444164	-	-
LCA63	1400	14°-16°	0.75	15	5.3	D.O.L	444744	444704	10314107	444165	-	-
LCA63	1400	18°-24°	1.1	22	7	D.O.L	444744	444705	10314120	444165	-	-
LCA63	1400	22°-26°	1.5	32	9.3	D.O.L	444744	444706	10314120	-	-	-

### 3 Phase 4 Pole

Stock Ref	rpm	Pitch Angle	Motor kW	S.C. Amps	F.L.C Amps	Starting Method	Starter Ref	Overload Ref	Transform Controller	eDemand Controller	
										Voltage Control	3 Phase Inverter
LCA25	1400	25°-40°	0.25	4.26	0.71	D.O.L	444747	444699	10314301	444166	444172
LCA31	1400	10°-38°	0.25	5.04	0.84	D.O.L	444747	444699	10314301	444166	444172
LCA35	1400	10°-38°	0.25	5.04	0.84	D.O.L	444747	444699	10314301	444166	444172
LCA40	1400	10°-26°	0.25	5.04	0.84	D.O.L	444747	444699	10314301	444166	444172
LCA40	1400	28°-38°	0.25	5.04	0.84	D.O.L	444747	444699	10314301	444166	444172
LCA40	1400	40°	0.37	6.66	1.11	D.O.L	444747	444700	10314301	444166	444172

## Speed Controllers

Used in conjunction with speed controllable fans Vent-Axia offers a choice of speed controllers, the traditional Five-Step Auto Transformer or the Inverter Speed Controller.

The Five-Step-Auto Transformer provides five stepped speed settings without the electronic motor harmonic noise associated with all electronic or solid state type Speed Controllers.

eDemand Speed Controllers & Inverters see Accessories and Controls Section.

# Electrical Details

## 3 Phase 4 Pole

Stock Ref	rpm	Pitch Angle	Motor kW	S.C. Amps	F.L.C Amps	Starting Method	Starter Ref	Overload Ref	Transform Controller	eDemand Controller	
										Voltage Control	3 Phase Inverter
LCA45	1400	10°24°	0.25	5.04	0.84	D.O.L.	444747	444699	10314301	444166	444172
LCA45	1400	26°32°	0.37	6.66	1.11	D.O.L.	444747	444700	10314301	444166	444172
LCA45	1400	34°40°	0.55	9.48	1.58	D.O.L.	444747	444701	10314304	444166	444172
LCA50	1400	10°18°	0.25	5.04	0.84	D.O.L.	444747	444699	10314301	444166	444172
LCA50	1400	20°26°	0.37	6.66	1.11	D.O.L.	444747	444700	10314301	444166	444172
LCA50	1400	28°34°	0.55	9.48	1.58	D.O.L.	444747	444701	10314304	444166	444172
LCA50	1400	36°40°	0.75	11.58	1.93	D.O.L.	444747	444701	10314304	444166	444172
LCA56	1400	10°16°	0.55	9.48	1.58	D.O.L.	444747	444701	10314304	444166	444172
LCA56	1400	18°22°	0.75	11.58	1.93	D.O.L.	444747	444702	10314304	444166	444172
LCA56	1400	24°30°	1.1	15.84	2.64	D.O.L.	444747	444702	10314304	444166	444173
LCA56	1400	32°36°	1.5	20.7	3.45	D.O.L.	444747	444702	10314304	444166	444173
LCA56	1400	38°40°	2.2	33.9	4.84	D.O.L.	444747	444703	10314307	444167	444174
LCA63	1400	10°	0.55	9.48	1.58	D.O.L.	444747	444701	10314304	444166	444172
LCA63	1400	12°14°	0.75	11.58	1.93	D.O.L.	444747	444701	10314304	444166	444172
LCA63	1400	16°18°	1.1	15.84	2.64	D.O.L.	444747	444702	10314304	444166	444173
LCA63	1400	22°26°	1.5	20.7	3.45	D.O.L.	444747	444702	10314307	444166	444173
LCA63	1400	28°34°	2.2	33.9	4.84	D.O.L.	444747	444703	10314307	444167	444174
LCA63	1400	36°40°	3	45.3	6.47	D.O.L.	444747	444704	10314311	444167	444174
LCA71	1420	10°	0.75	11.58	1.93	D.O.L.	444747	444701	10314304	444166	444172
LCA71	1420	12°14°	1.1	15.84	2.64	D.O.L.	444747	444702	10314304	444166	444173
LCA71	1420	16°18°	1.5	20.7	3.45	D.O.L.	444747	444702	10314304	444166	444173
LCA71	1420	20°24°	2.2	33.9	4.84	D.O.L.	444747	444703	10314307	444167	444174
LCA71	1420	26°30°	3	45.3	6.47	D.O.L.	444747	444704	10314311	444167	444174
LCA71	1420	32°36°	4	57.8	8.26	D.O.L.	444747	444705	10314311	444167	444175
LCA71	1420	38°40°	5.5	77	11	D.O.L.	444748	444706	-	-	444175
LCA80	1420	10°12°	2.2	33.9	4.84	D.O.L.	444747	444703	10314307	444167	444174
LCA80	1440	14°20°	3	45.3	6.47	D.O.L.	444747	444704	10314311	444167	444174
LCA80	1440	22°24°	4	57.8	8.26	D.O.L.	444747	444705	10314311	444167	444175
LCA80	1440	26°28°	5.5	77	11	D.O.L.	444748	444706	-	-	444175
LCA80	1440	30°34°	7.5	102.2	14.6	D.O.L.	444748	444707	-	-	444176
LCA80	1440	36°40°	11	52.3	20.9	Star Delta	444843	444707	-	-	-
LCA90	1440	10°	3	45.3	6.47	D.O.L.	444747	444704	10314311	444167	444174
LCA90	1440	12°16°	4	57.8	8.26	D.O.L.	444747	444705	10314311	444167	444175
LCA90	1440	18°20°	5.5	77	11	D.O.L.	444748	444706	-	-	444175
LCA90	1440	22°26°	7.5	102.2	14.6	D.O.L.	444748	444707	-	-	444176
LCA90	1440	28°32°	11	52.3	20.9	Star Delta	444843	444707	-	-	-
LCA90	1440	34°40°	15	75.3	30.1	Star Delta	-	-	-	-	-
LCA100	1440	10°12°	4	57.8	8.26	D.O.L.	444747	444705	10314311	444167	444175
LCA100	1440	14°16°	5.5	77	11	D.O.L.	444748	444706	-	-	444175
LCA100	1440	18°22°	7.5	102.2	14.6	D.O.L.	444748	444707	-	-	444176
LCA100	1440	24°26°	11	52.3	20.9	Star Delta	444843	444707	-	-	-
LCA100	1440	28°32°	15	75.3	30.1	Star Delta	-	-	-	-	-
LCA100	1440	34°38°	18.5	86	34.3	Star Delta	-	-	-	-	-
LCA100	1440	40°	22	102	40.6	Star Delta	-	-	-	-	-
LCA125	1475	20°	22	102	40.6	Star Delta	-	-	-	-	-
LCA125	1475	22°24°	30	131	54.7	Star Delta	-	-	-	-	-
LCA125	1475	26°30°	37	159	66.4	Star Delta	-	-	-	-	-
LCA125	1475	32°34°	45	193	80.5	Star Delta	-	-	-	-	-

### Fan Attenuator Details

An attenuator without Pod offers negligible resistance to air flow, and therefore the pressure loss can be considered to be the same as that for the equivalent length of ducting.

Resistance Graph for Axial Attenuator with Pod

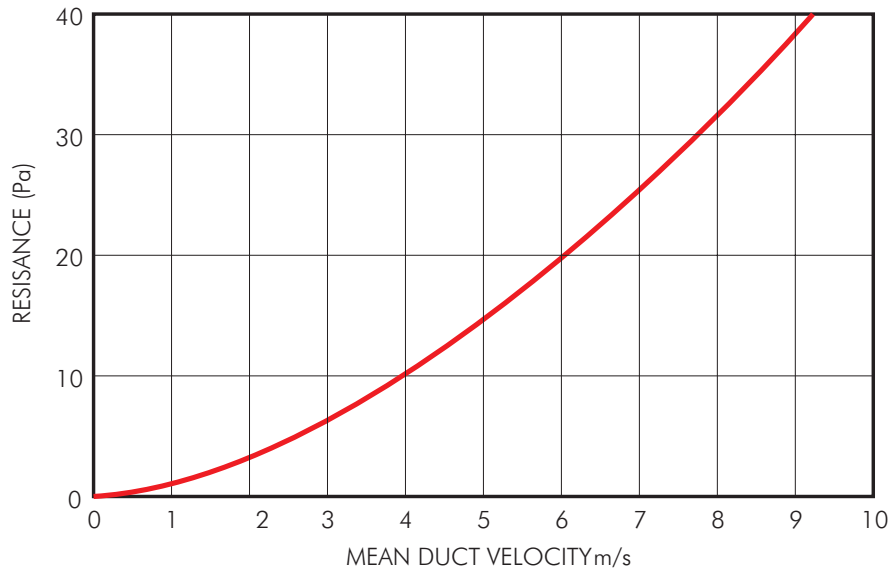

Attenuator Insertion Loss Data

Dia	Stock Ref	63	125	250	500	1k	2k	4k	8k	kg approx
250	10514250	2	3	6	11	16	11	10	6	20
315	10514315	2	3	6	11	16	11	10	6	22
355	10514355	2	3	6	12	16	11	10	6	30
400	10514400	2	3	6	13	16	12	10	6	41
450	10514450	2	4	6	14	17	12	10	6	50
500	10514500	3	4	7	14	17	14	11	7	59
560	10514560	2	4	8	15	18	14	11	7	70
630	10514630	3	4	8	16	18	14	11	7	82
710	10514710	1	2	6	9	12	10	6	2	90
800	10514800	1	2	6	9	12	10	6	2	100
900	10514900	1	2	6	9	12	10	6	2	145
1000	10514000	1	2	6	9	12	10	6	2	184
1250	105141250	1	2	6	9	12	10	6	2	150

Melinex lined attenuators are available on request

Case Axial Attenuator Fitted with Pod Insertion Losses

Dia	Stock Ref	63	125	250	500	1k	2k	4k	8k	kg approx
315	10500315	6	7	12	18	27	25	22	19	32
355	10500355	3	8	12	18	28	26	22	19	44
400	10500400	3	8	12	18	28	26	23	19	60
450	10500450	4	8	14	20	28	26	23	19	73
500	10500500	4	8	14	20	29	26	23	19	87
560	10500560	4	9	14	20	29	26	23	19	102
630	10500630	4	9	14	20	29	26	23	19	120
710	10500710	6	10	20	30	35	28	25	22	134
800	10500800	6	10	20	30	35	28	25	22	149
900	10500900	6	10	20	30	35	28	25	22	211
1000	105001000	6	10	20	30	35	28	25	22	267
1250	105001250	6	10	17	28	27	21	18	17	222

Attenuator Dimensions (mm)

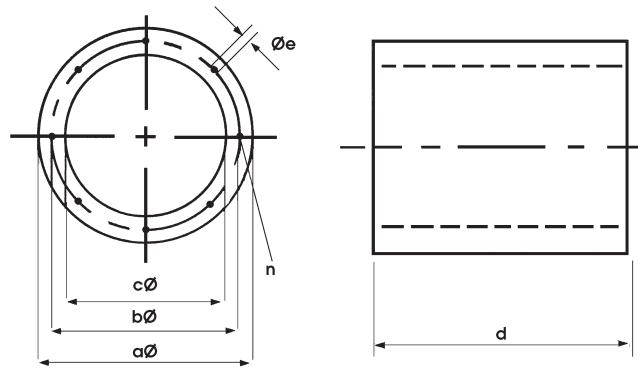

Model	Stock		a Ø	b Ø	c Ø	d	e Ø	n
	Ref							
LCA25	10514250		350	292	254	375	M8	4
LCA31	10514315		415	355	315	475	M8	8
LCA35	10514355		455	395	355	540	M8	8
LCA40	10514400		500	450	400	600	M10	8
LCA45	10514450		550	500	450	675	M10	8
LCA50	10514500		600	560	500	750	M10	12
LCA56	10514560		660	620	560	810	M10	12
LCA63	10514630		730	690	630	940	M10	12
LCA71	10514710		814	700	710	1070	M10	16
LCA80	10514800		900	860	796	1200	M10	16
LCA90	10514900		999	970	893	1350	M10	16
LCA100	105141000		1108	1070	1070	1500	M10	16
LCA125	105141250		1350	1320	1250	1875	M10	20

## Accessory Dimensions (mm)

### Coupling Flange

Rolled from mild steel. Dimensionally matched to fan flange and fixing holes.

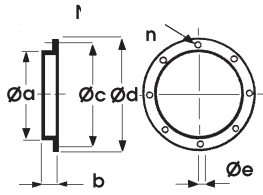

Stock Ref	a Ø	b	c Ø	d Ø	e Ø	n
10506250	335	30	295	250	10	8
10506315	385	30	355	315	10	8
10506355	425	45	395	355	10	8
10506400	480	45	450	400	12	8
10506450	530	60	500	450	12	8
10506500	590	0	560	500	12	12
10506560	650	75	620	560	12	12
10506630	720	75	690	630	12	12
10506710A	800	40	770	710	12	16
10506800A	890	40	860	800	12	16
10506900A	1038	50	970	900	14	16
105061000A	1138	50	1070	1000	14	16
105061250A	1390	83	1320	1250	15	20

### Anti-Vibration Mounts

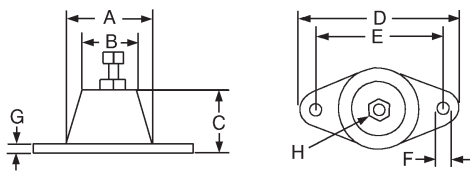

Max. Load

*Stock Ref	A	B	C	D	E	F	G	H	kg
68MP033G	37	26	27	67	54	7	3	M 8	23
68MP055B	37	26	27	67	54	7	3	M8	36
68MP133G	57	46	35	95	76	10.5	4	M12	91
68MP165R	57	46	35	95	76	10.5	4	M12	245

\*supplied as a set of 4.

### Inlet Wire Guard

'K' factor loss 0.25

Available for direct fixing to either side of the fan using flange sizing holes. Constructed to meet BS 848 Part 5.

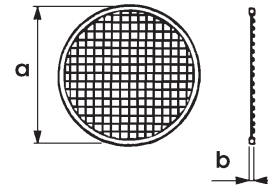

Stock Ref	a	b
10505250	330	3
10505315	380	3
10505355	420	3
10505400	475	3
10505450	525	3
10505500	595	3
10505560	655	3
10505630	725	3
10505710	784	10
10505800	870	10
10505900	970	10
105051000	1090	10
105051250	1370	10

For more information on the 'K' factor, refer to General Information Section

### Mounting Feet

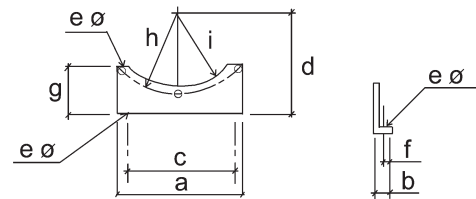

*Stock Ref	a	b	c	d	e	f	g	h	i
10503250	232	24	180	240	10	14	115	146	130
10503315	275	24	224	240	10	14	115	177.5	167
10503355	303	24	250	250	10	14	125	197.5	187
10503400	348	24	280	300	12	14	135	225	213
10503450	384	24	315	360	12	14	155	250	238
10503500	425	24	315	360	12	14	135	280	268
10503560	475	24	355	355	12	14	155	310	298
10503630	520	24	400	400	12	14	175	345	333
10503710A	710	40	610	435	13	18	240	385	365
10503800A	800	40	700	480	13	18	262	430	410
10503900A	900	40	800	535	13	18	288	485	460
105031000A	1000	40	900	580	15	18	314	535	510
105031250A	1250	80	1150	868	15	26	366	660	640

\*Set of 2 feet

## Accessories

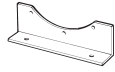

Model Ref	Mounting Feet - set of 2 Stock Ref	Inlet Wire Guard Stock Ref	Coupling Flange Stock Ref	*Ancillary Pack Stock Ref	Axial Attenuator Stock Ref	Attenuator inc. Pod Stock Ref	** Anti Vibration Mount Stock Ref
LCA25	10503250	10505250	10506250	10513250	10514250	-	68MP033G
LCA31	10503315	10505315	10506315	10513315	10514315	10500315	68MP033G
LCA35	10503355	10505355	10506355	10513355	10514355	10500355	68MP033G
LCA40	10503400	10505400	10506400	10513400	10514400	10500400	68MP033G
LCA45	10503450	10505450	10506450	10513450	10514450	10500450	68MP033G
LCA50	10503500	10505500	10506500	10513500	10514500	10500500	68MP033G
LCA56	10503560	10505560	10506560	10513560	10514560	10500560	68MP033G
LCA63	10503630	10505630	10506630	10513630	10514630	10500630	68MP033G
LCA71	10503710A	10505710	10506710A	10513710A	10514710A	10500710	68MP055B
LCA80	10503800A	10505800	10506800A	10513800A	10514800A	10500800	68MP055B
LCA90	10503900A	10505900	10506900A	10513900A	10514900A	10500900	68MP133G
LCA100	105031000A	105051000	105061000A	105131000A	105141000A	105001000	68MP133G
LCA125	105031250A	105051250	105061250A	105131250A	105141250A	105001250	68MP165R

\*consists of 2 Matching Flanges, 2 Flexible Connectors, 2 Mounting Feet, 4 Anti Vibration Mounts, 4 Worm Drive Clips

## Typical Installation

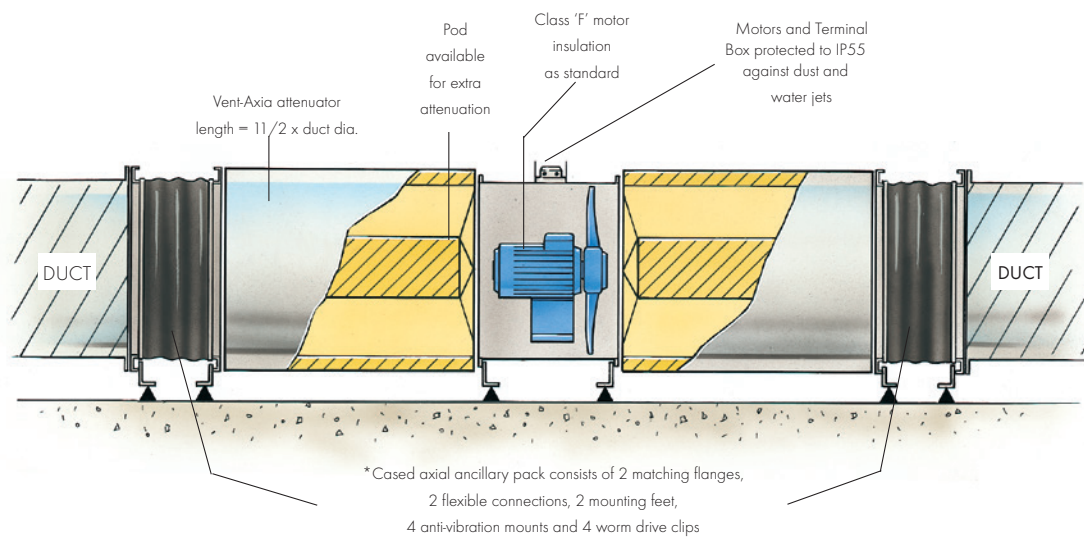

# Kitchen Axial Fan (KAF)

- Fully ERP 2015 compliant
- Designed to operate at elevated temperatures (70°C max)
- All models speed controllable via matched eDemand inverter controls
- Robust motor construction for aggressive conditions
- Die cast aluminium impellers
- IP65 motor and terminal box, suitable for internal or external mounting as standard
- Motor insulation class H, suitable for induct operating temperatures of -40°C to +70°C
- Standard Thermal Overload Protection
- Maximum operating temperature indicator label

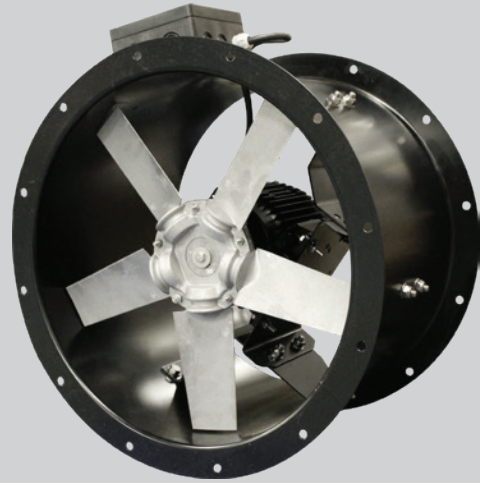

The ever tightening requirement for kitchen ventilation systems with higher filtration levels and long duct runs requires a powerful and yet compact fan to provide a cost-effective controllable ventilation solution suitable for operating reliably in atmospherically aggressive installations.

A first within the H&V industry, Vent-Axia's New Kitchen Axial Fan range provides such a solution offering robustly engineered fans and motors designed and tested for operation at elevated temperatures (up to 70°C induct) whilst utilising speed control. Utilising Vent-Axia's advanced eDemand Inverter controls provides accurate and reliable control functionality whilst offering substantial running cost reductions and noise control.

Available in four sizes: 450, 500, 560 and 630mm diameter with a performance envelope from 0.65m<sup>3</sup>/s to 5.93m<sup>3</sup>/s and pressure development of up to 600 Pa. Ensuring a compact design, the units have been constructed from a single sheet of steel, with a single 2 pole motor and axial impeller mounted within the length of the unit casing. The unit is manufactured from electro welded steel with an epoxy paint finish. Factory assembled to BS EN ISO 9001:2015 ensuring a quiet and vibration free unit.

All sizes are protected with a tough black epoxy paint finish for those harsh environmental conditions, internally or externally. Ensuring ease of installation the motor is wired directly into a single IP65 terminal box.

---

## Axial Impellers

The impeller is manufactured in die-cast aluminium and fitted with narrow profiled blades, which provide the maximum efficiency at the maximum airflow. Airflow is Form A to ensure maximum cooling airflow over the motor.

---

## Motors

Specifically designed for this range of fans and the expected environmental conditions. Greased for life ball bearings with temperature resilient grease specially selected to operate at the elevated temperatures

likely to be encountered in kitchen applications whilst allowing the fans to be installed at any angle. Rotors are dynamically balanced to ISO 1940 grade G6.3. Motors are protected to IP65 against dust and water jets complying with BS EN 60529. They have ribbed aluminium body castings and are mounted towards the airstream for efficient cooling. Motor insulation is Class 'H' (from -40°C to +70°C). All models are speed controllable by either voltage control or frequency inverter (see electrical section for details).

---

## Electrical

Single phase 220-240V/50 Hz. Capacitor start and run. Three phase 380V-415V/50Hz. All motors are fitted with Standard Thermal Overload Protection (S.T.O.P), which should be wired into all controller circuits and into starter contactors.

---

## Terminal Box

IP65 terminal box is supplied with all models with 20mm PGII entry.

---

## Performance

The fan performance is tested and certified in accordance with BS 848 Part 1 1980.

---

## Sound Levels

Fan sound levels, measured in a reverberant chamber in accordance with BS848 part 2 published dB(A) figures are free field sound pressure levels at 3m with spherical propagation at reference level of 2 x10<sup>-5</sup>Pa (20 micro-pascal). The sound power level spectra figures are dB with a reference level of 10-12 Watts (1 pico-watt). To ensure minimum noise levels during speed control, an auto transformer speed control is recommended.



## Accessories

- eDemand Inverter Speed Controllers
- Auto Transformer Speed Controllers
- Mounting Ancillary Packs
- Cased Attenuators
- Mounting Feet
- Wire Inlet Guard
- Coupling Flanges

## Warranty

Standard 2 year warranty, extendable to 5 years by registration, subject to installation and maintenance in accordance with fitting and operating instructions supplied with product.

## Performance Curve

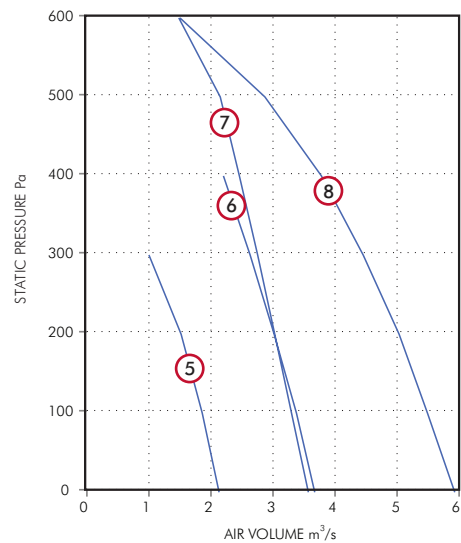
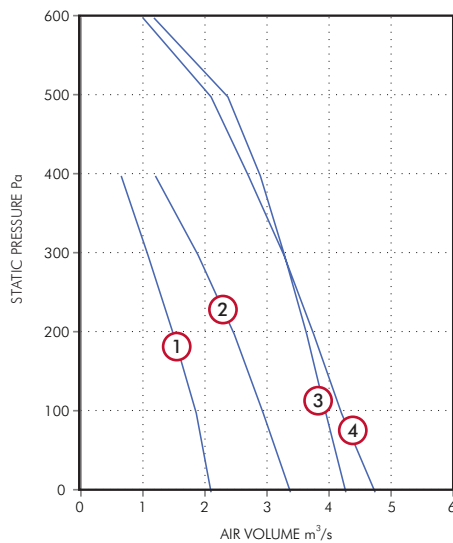

## Performance Guide

Stock Ref	Speed		Pole	Curve	Performance										Motor	Amps	Amps
	rpm	Phase			0	50	100	150	200	300	400	500	600	kW			
KAF45012	2850	1	2	1	2.1	2	1.86	1.69	1.49	1.08	0.65			1.1	29	6.6	
KAF50012	2850	1	2	2	3.38	3.2	2.94	2.73	2.47	1.89	1.2			1.5	35	7.8	
KAF56012	2800	1	2	3	4.27	4.1	3.95	3.81	3.64	3.28	2.89	2.37	1.18	2.2	66	15	
KAF63012	2860	1	2	4	4.74	4.5	4.2	4	3.75	3.27	2.7	2.1	1.00	3	80	13.5	
KAF45032	2830	3	2	5	2.13	2	1.86	1.72	1.52	1				1.1	11	2	
KAF50032	2830	3	2	6	3.67	3.56	3.38	3.23	3.02	2.63	2.2			1.5	17	3.4	
KAF56032	2760	3	2	7	3.57	3.45	3.3	3.16	3.03	2.75	2.46	2.15	1.48	2.2	32	4.9	
KAF63032	2785	3	2	8	5.93	5.69	5.49	5.26	5.03	4.45	3.78	2.87	1.5	4	66	7.8	

## Sound Power Level Spectra dB (re 10<sup>-12</sup>Watts)

Stock Ref	Phase	Pole	125	250	500	1k	2k	4k	8k	dB(A) @ 3m	
KAF45012	Inlet/Outlet	1	2	70	71	79	82	82	79	74	67
KAF50012	Inlet/Outlet	1	2	70	76	79	81	81	80	75	67
KAF56012	Inlet/Outlet	1	2	79	94	97	99	98	94	86	78
KAF63012	Inlet/Outlet	1	2	79	90	98	99	98	97	91	81
KAF45032	Inlet/Outlet	3	2	63	73	80	82	83	81	76	68
KAF50032	Inlet/Outlet	3	2	69	80	83	84	85	84	80	70
KAF56032	Inlet/Outlet	3	2	86	98	97	97	92	87	80	75
KAF63032	Inlet/Outlet	3	2	79	90	98	98	99	97	91	81

Published dB(A) figures are free field sound levels at 3m with spherical propagation at a reference level of 2x10<sup>-5</sup> Pa. The free field sound power level spectra figure are dB with reference of 10<sup>-12</sup> Watts. To ensure minimum noise levels during speed control an auto transformer or inverter speed controller is recommended.

### Fan Dimensions (mm)

Size	øa	b	øc	ød	øe	n	kg approx
450	450	375	500	530	12	8	41
500	500	375	560	590	12	12	46
560	560	520	620	650	12	12	59
630	630	520	690	720	12	12	64

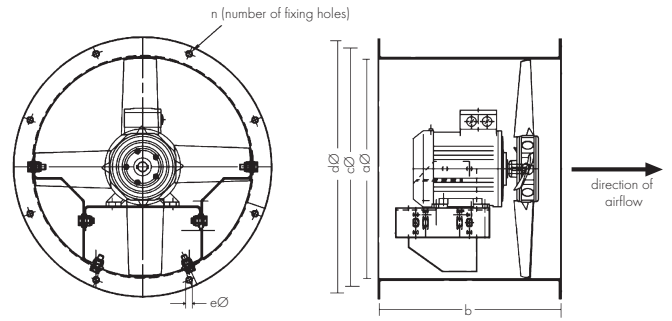

### Attenuator Insertion Losses

Dia	63	125	250	500	1k	2k	4k	8k
450	2	4	6	14	17	12	10	6
500	3	4	7	14	17	14	11	7
560	3	4	8	15	18	14	11	7
630	3	4	8	16	18	14	11	7

### Attenuator Fitted with Pod Insertion Losses

Dia	63	125	250	500	1k	2k	4k	8k
450	4	8	14	20	28	26	23	19
500	4	8	14	20	29	26	23	19
560	4	9	14	20	29	26	23	19
630	4	9	14	20	29	26	23	19

### Accessories Dimensions (mm)

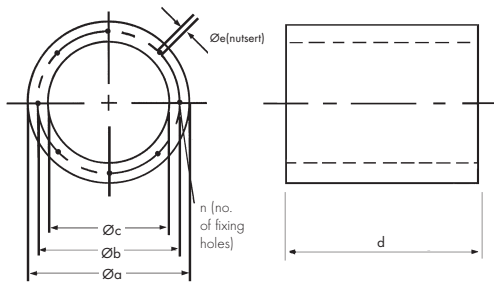

### Resistance Graph For Case Attenuator Fitted With Pod

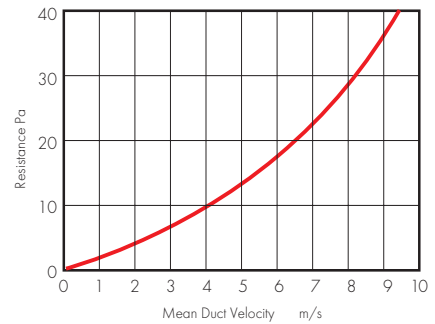

### Case Axial Attenuator

Dia	øa	bø	øc	d	øe*	n	kg	Fitted with pod	Free area
							approx	kg approx	m <sup>2</sup> without pod
450	550	500	450	675	M10	8	50	73	0.159
500	600	560	500	750	M10	12	59	87	0.196
560	660	620	560	840	M10	12	70	102	0.246
630	730	690	630	940	M10	12	82	120	0.312

\*Threaded hole to take bolt

### Mounting Feet

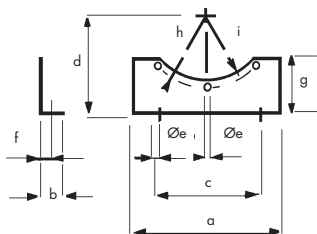

Stock Ref	a	b	c	d	øe	f	g	h	i
10503450	384	24	315	315	12	14	155	250	238
10503500	425	24	315	315	12	14	135	280	268
10503560	475	24	355	355	12	14	155	310	298
10503630	520	24	400	400	12	14	175	345	333

### Inlet Wire Guard

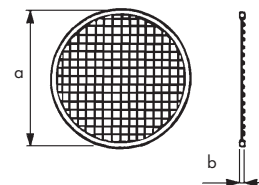

'K' factor loss 0.25

Stock

Ref	øa	b
10505450	525	3
10505500	595	3
10505560	655	3
10505630	725	3

For more information on the 'K' factor, refer to General Information Section

## Accessories Dimensions (mm)

### Anti-Vibration Mounts

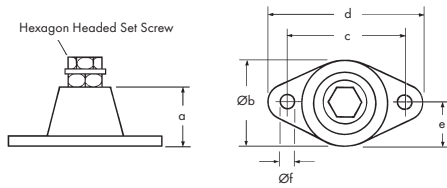

Ref	a	Øb	c	d	e	Øf	n	Max load kg
68MP033G	27	37	54	67	18.5	7	M8	23

\* 4 required per fan

### Coupling Flange

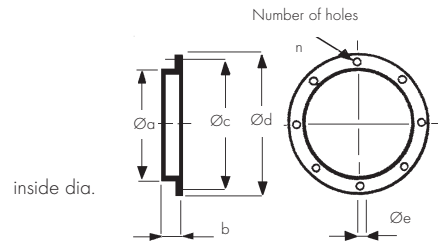

Stock Ref No.	Øa	b	Øc	Ød	Øe	n
10506450	450	60	500	537	12	8
10506500	500	60	560	595	12	12
10506560	560	75	620	655	12	12
10506630	630	75	690	725	12	12

## Accessories

### Mounting

Stock Ref	Ancillary Pack *	Case Axial Attenuator				Anti Vibration Mounts	
		Case Axial Attenuator	in Pod	Mounting Feet	Coupling Flange	Inlet Wire Guard	#
KAF45012	10513450	10514450	10500450	10503450	10506450	10505450	68MP033G
KAF50012	10513500	10514500	10500500	10503500	10506500	10505500	68MP033G
KAF56012	10513560	10514560	15000560	10503560	10506560	10505560	68MP033G
KAF63012	10513630	10514630	10500630	10503630	10506630	10505630	68MP033G
KAF45032	10513450	10514450	10500450	10503450	10506450	10505450	68MP033G
KAF50032	10513500	10514500	10500500	10503500	10506500	10505500	68MP033G
KAF56032	10513560	10514560	15000560	10503560	10506560	10505560	68MP033G
KAF63032	10513630	10514630	10500630	10503630	10506630	10505630	68MP033G

### Manual Starter

### eDemand Controls\*\*

Stock Ref	Starter	Overload	Single Phase Inverter	3 Phase Inverter	Voltage Control	Transformer Control
KAF45012	444744	444705	444171	-	444165	10314113
KAF50012	444744	444705	444171	-	444165	10314113
KAF56012	444744	444707	-	-	-	-
KAF63012	444744	444707	-	-	-	-
KAF45032	444747	444702	-	444172	444166	10314304
KAF50032	444747	444702	-	444173	444166	10314304
KAF56032	444747	444703	-	444173	-	-
KAF63032	444747	444705	-	444174	-	-

\* Includes 4 Anti Vibration Mounts, 2 Mounting Feet, 2 Flanges and 2 Flexible Connectors

\*\* For Manual control requires Speed Potentiometer 426332

# 4 required per fan

x Not suitable

# Bifurcated Case Axial Fans (BIFA)

- Sizes 250 to 1000 dia
- Motors protected to IP55
- Motor insulation Class 'F'
- Maximum ambient temperature 200°C
- Speed controllable via transformer or inverter (when the ambient air temperature is not higher than 60°C)
- IP55 terminal box
- Suitable for relative humidity levels up to 95% RH
- Manufactured to BS EN ISO 9001:2015
- Performance tested to BS 848 parts 1, 2 and ISO 5801
- 2 Year Guarantee



The Bifurcated Case Axial range has been specifically developed to meet the need for an axial fan which can handle atmospheres normally detrimental to the life of the fan motor.

By isolating the motor from the system airstream, the bifurcated fan can handle a wide variety of saturated and dust-laden atmospheres, heated air and hot gases.

The range has a split airway with a direct driven motor operating in ambient air within the motor compartment. They are suitable, as standard, for handling air temperatures up to +200°C.

The Bifurcated Case Axial Fan range has a number of accessories available which include: Axial Ancillary Pack, Attenuator, Wire Inlet Guard, Coupling Flanges, Mounting Feet, AV Mounts and Speed Controllers.

---

## Motors

The motors are specially selected to operate within the motor compartment with the airstream in the duct system, at an elevated temperature.

Motors are of the B3 foot mounting type, totally enclosed and fan cooled. Being foot mounted the motors can, in the event of a failure, be readily interchanged with a comparable frame size from a wide range of manufacturers to cover temperatures of up to 200°C.

Where indicated, the motor is suitable for speed control by either an inverter or a 5-step auto transformer speed controller when the ambient air temperature is not higher than 60°C.

---

## Electrical

Single phase 220-240V/50 Hz supply are available in two sizes 250 and 315 dia. in either 2 or 4 pole versions. Three phase 380-440V/50Hz supply are available in nine sizes 250, 315, 400, 500, 630, 710, 800, 900 and 1000 dia. in either 2 or 4 pole versions (710, 800, 900 and 1000 dia are only available as 4 pole).

---

---

## Impellers and Casing

The aluminium alloy impellers are die cast and have an adjustable pitch which allows a wide range of air outputs to be selected. All the casings are manufactured in steel and hot dipped galvanised to BS EN ISO 1461 after fabrication. Motor mountings and fixings used in the assembly of the fan are zinc plated and passivated.

---

## Form of Running

Bifurcated fans have arrows showing the direction of the impeller rotation and airflow. All models are Form B running.

---

## Terminal Box

To IP55, protected against dust and water jets from any angle, allowing outside applications.

---

## Performance

Tested to BS 848 Part 1 & 2. Published dB(A) figures are free field sound pressure levels at 3m with spherical propagation at a reference level of  $2 \times 10^{-5}$  Pa (20 micro-Pascal). The inlet and outlet sound power level spectra figures are dB with a reference of  $10^{-12}$  Watts (1 pico-Watt).

---

## Cooling

External cooling is provided by a fan mounted at the non-drive end of the motor, protected by a cover with a grid air intake. The airflow, guided by the fan cover, is directed longitudinally on the entire periphery of the motor in the channels formed by the frame ribs.

Adequate space is provided within the motor compartment to ensure a plentiful supply of cooling air. The air within the motor compartment must not exceed 40°C. For ambients in excess of this, please consult our Technical Services Department for further information.

---

Fan Dimensions (mm)  
BIFA25 - BIFA50

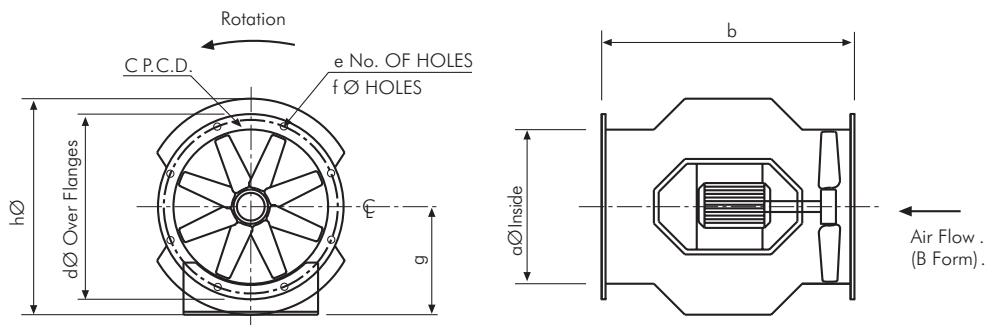

Model No.	Pole	Phase	Pitch Angle	aØ	b	c	d	e	f	g	hØ	Approx. Weight kg
BIFA25	2&4	1&3	25-40	250	535	302	328	8	10	240	452	30
BIFA31	2&4	1&3	10-38	315	535	355	385	8	10	240	452	35
BIFA40	2&4	1&3	10-38	400	625	450	480	8	10	335	585	49
BIFA45	2&4	1&3	10-40	450	625	500	535	8	12	360	650	60
BIFA50	4	1&3	10-40	500	660	560	590	12	12	360	695	66
BIFA50	2	3	10-40	500	710	560	590	12	12	360	695	87

BIFA63 - BIFA100

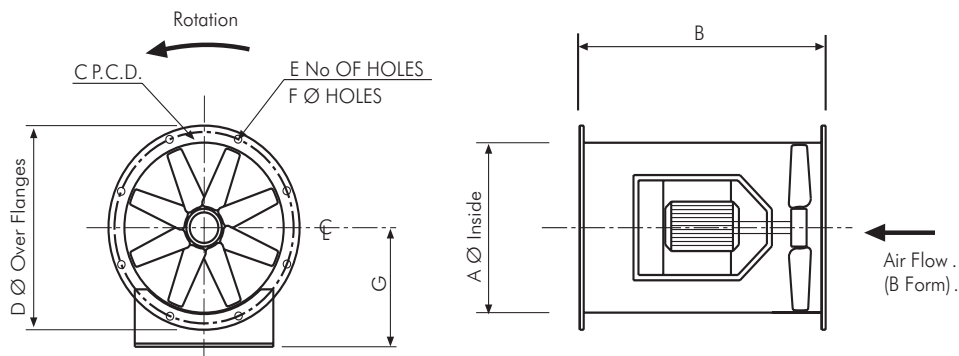

Model No.	Pole	Phase	Pitch Angle	a	b	c	d	e	f	g	Approx. Weight kg
BIFA56	2&4	3	10-40	560	800	604	644	12	12	350	80
BIFA63	2&4	3	10-40	630	790	690	728	12	12	400	106
BIFA71	4	3	10-40	710	800	754	784	16	12	435	120
BIFA80	4	3	10-40	800	880	860	890	16	12	450	155
BIFA90	4	3	10-40	900	900	970	1038	16	14	535	170
BIFA100	4	3	10-40	1000	1000	1070	1138	16	14	575	275

### Performance Curve

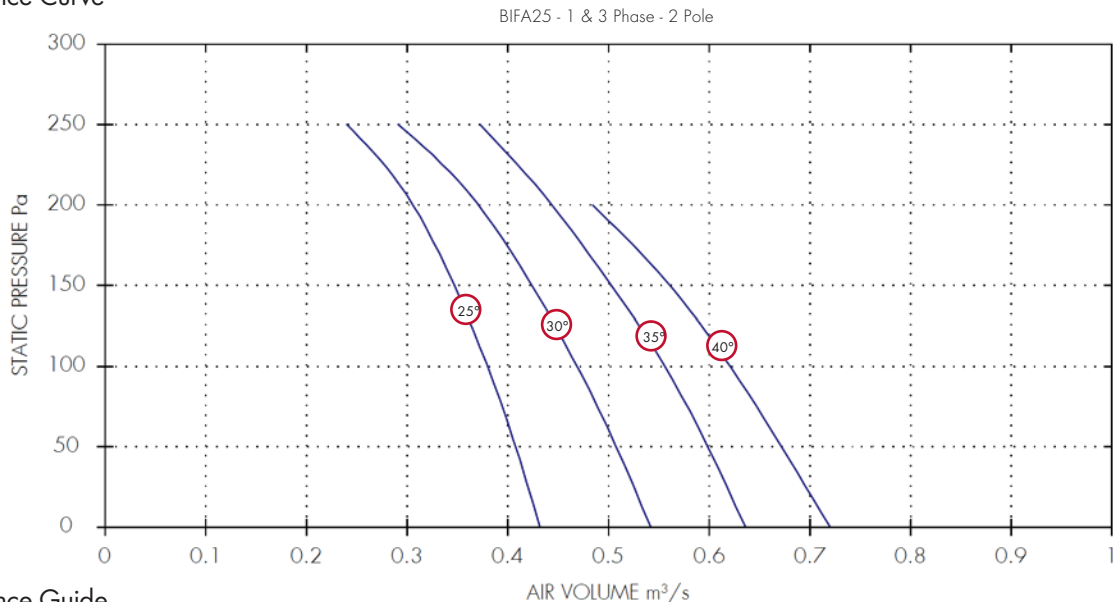

### Performance Guide

Dia.	1 Phase		3 Phase		IP Rating	Curve Ref	m³/s at Pa						Motor kW	dBA @3m
	Stock Ref	Stock Ref	Poles	rpm			0	50	100	150	200	250		
250	BIFA251225	BIFA253225	2	2800	IP55	25°	0.43	0.41	0.38	0.35	0.31	0.24	0.37	58
250	BIFA251230	BIFA253230	2	2800	IP55	30°	0.54	0.51	0.47	0.42	0.37	0.29	0.37	57
250	BIFA251235	BIFA253235	2	2800	IP55	35°	0.64	0.6	0.56	0.5	0.44	0.37	0.37	58
250	BIFA251240	BIFA253240	2	2800	IP55	40°	0.72	0.67	0.62	0.56	0.48		0.37	59

### Sound Power Level Spectra dB (ref 10<sup>-12</sup> Watts)

Dia.	1 Phase		3 Phase		Spectrum	dB							dBA @ 3m	
	Stock Ref	Stock Ref	Poles	rpm		63	125	250	500	1k	2k	4k		8k
250	BIFA251225	BIFA253225	2	2800	Inlet/Outlet	73	74	82	75	73	70	67	64	58
250	BIFA251230	BIFA253230	2	2800	Inlet/Outlet	72	73	81	74	72	69	66	63	57
250	BIFA251235	BIFA253235	2	2800	Inlet/Outlet	73	74	82	75	73	70	67	64	58
250	BIFA251240	BIFA253240	2	2800	Inlet/Outlet	74	75	83	76	74	71	68	65	59

Performance Curve

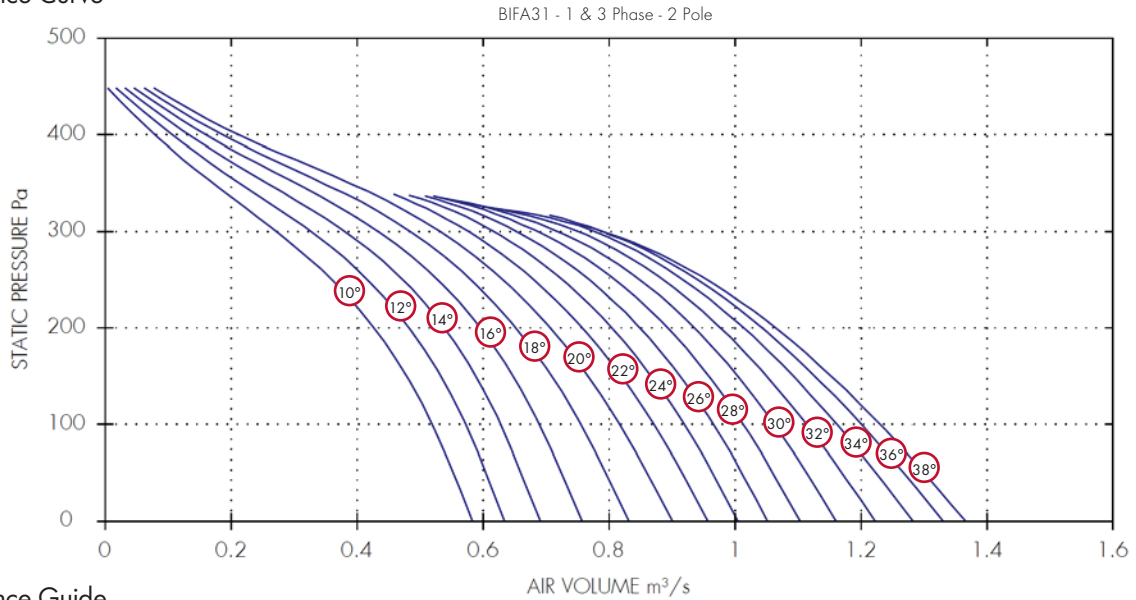

Performance Guide

Dia.	1 Phase		3 Phase		IP	Curve	m³/s at Pa					Motor kW	dBa @3m
	Stock Ref	Stock Ref	Poles	rpm			Rating	Ref	0	100	200		
315	BIFA311210	BIFA313210	2	2800	IP55	10°	0.58	0.52	0.43	0.27	0.08	0.37	65
315	BIFA311212	BIFA313212	2	2800	IP55	12°	0.63	0.57	0.48	0.33	0.11	0.37	65
315	BIFA311214	BIFA313214	2	2800	IP55	14°	0.69	0.63	0.54	0.38	0.13	0.37	65
315	BIFA311216	BIFA313216	2	2800	IP55	16°	0.76	0.69	0.6	0.43	0.16	0.37	63
315	BIFA311218	BIFA313218	2	2800	IP55	18°	0.83	0.76	0.65	0.48	0.19	0.37	61
315	BIFA311220	BIFA313220	2	2800	IP55	20°	0.9	0.82	0.71	0.53	0.21	0.37	61
315	BIFA311222	BIFA313222	2	2800	IP55	22°	0.96	0.87	0.76	0.58	0.21	0.37	62
315	BIFA311224	BIFA313224	2	2800	IP55	24°	1	0.92	0.8	0.62	0.21	0.37	63
315	BIFA311226	BIFA313226	2	2800	IP55	26°	1.05	0.97	0.85	0.65	0.21	0.55	63
315	BIFA311228	BIFA313228	2	2800	IP55	28°	1.1	1.01	0.89	0.69	0.21	0.55	63
315	BIFA311230	BIFA313230	2	2800	IP55	30°	1.16	1.06	0.94	0.72	0.21	0.55	64
315	BIFA311232	BIFA313232	2	2800	IP55	32°	1.22	1.11	0.98	0.75	0.21	0.55	66
315	BIFA311234	BIFA313234	2	2800	IP55	34°	1.28	1.16	1.01	0.78	0.21	0.75	66
315	BIFA311236	BIFA313236	2	2800	IP55	36°	1.33	1.2	1.04	0.79	0.21	0.75	66
315	BIFA311238	BIFA313238	2	2800	IP55	38°	1.37	1.23	1.06	0.79	0.21	0.75	66

Sound Power Level Spectra dB (ref 10<sup>-12</sup> Watts)

Dia.	1 Phase		3 Phase		Spectrum	dB								dBa @ 3m
	Stock Ref	Stock Ref	Poles	Rating		63	125	250	500	1k	2k	4k	8k	
315	BIFA311210	BIFA313210	2	IP55	Inlet/Outlet	83	82	82	79	81	80	76	68	65
315	BIFA311212	BIFA313212	2	IP55	Inlet/Outlet	83	82	82	79	81	80	76	68	65
315	BIFA311214	BIFA313214	2	IP55	Inlet/Outlet	83	82	82	79	81	80	76	68	65
315	BIFA311216	BIFA313216	2	IP55	Inlet/Outlet	81	80	80	77	79	78	74	66	63
315	BIFA311218	BIFA313218	2	IP55	Inlet/Outlet	79	78	78	75	77	76	72	64	61
315	BIFA311220	BIFA313220	2	IP55	Inlet/Outlet	79	78	78	75	77	76	72	64	61
315	BIFA311222	BIFA313222	2	IP55	Inlet/Outlet	80	79	79	76	78	77	73	65	62
315	BIFA311224	BIFA313224	2	IP55	Inlet/Outlet	81	80	80	77	79	78	74	66	63
315	BIFA311226	BIFA313226	2	IP55	Inlet/Outlet	81	80	80	77	79	78	74	66	63
315	BIFA311228	BIFA313228	2	IP55	Inlet/Outlet	81	80	80	77	79	78	74	66	63
315	BIFA311230	BIFA313230	2	IP55	Inlet/Outlet	82	81	81	78	80	79	75	67	64
315	BIFA311232	BIFA313232	2	IP55	Inlet/Outlet	84	83	83	80	82	81	77	69	66
315	BIFA311234	BIFA313234	2	IP55	Inlet/Outlet	84	83	83	80	82	81	77	69	66
315	BIFA311236	BIFA313236	2	IP55	Inlet/Outlet	84	83	83	80	82	81	77	69	66
315	BIFA311238	BIFA313238	2	IP55	Inlet/Outlet	84	83	83	80	82	81	77	69	66



Performance Curve

BIFA40 - 1 & 3 Phase - 2 Pole

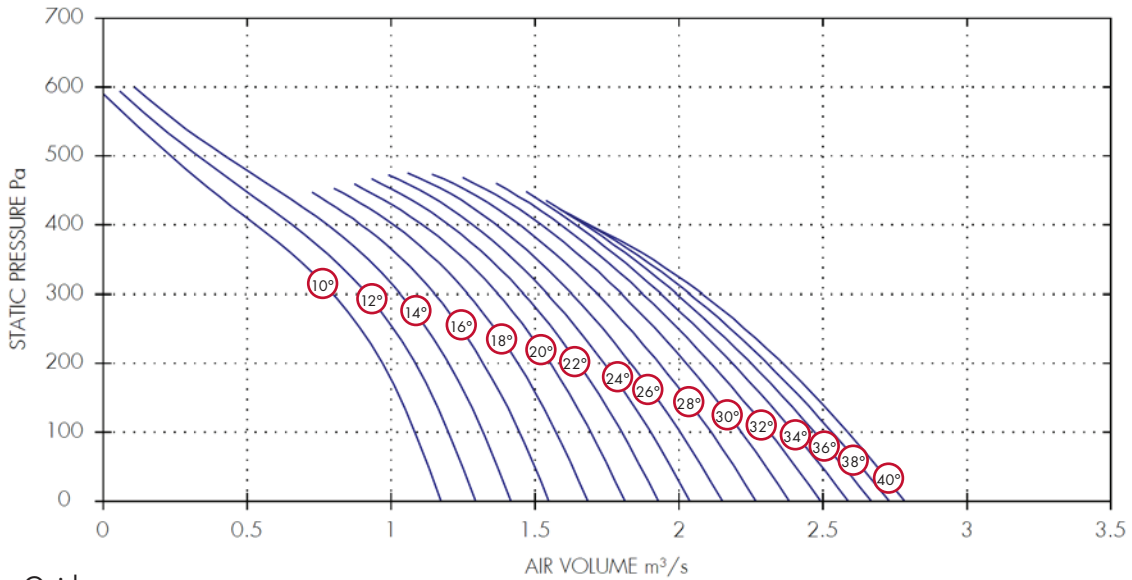

Performance Guide

Dia.	1 Phase		3 Phase		IP Rating	Curve Ref	m³/s at Pa						Motor kW	dBA @3m
	Stock Ref	Stock Ref	Poles	rpm			0	100	200	300	400	500		
400	BIFA401210	BIFA403210	2	2800	IP55	10°	1.17	1.08	0.97	0.8	0.53	0.23	0.55	71
400	BIFA401212	BIFA403212	2	2800	IP55	12°	1.29	1.2	1.09	0.92	0.66	0.33	0.55	71
400	BIFA401214	BIFA403214	2	2800	IP55	14°	1.42	1.32	1.2	1.03	0.78	0.42	0.75	71
400	BIFA401216	BIFA403216	2	2800	IP55	16°	1.55	1.45	1.32	1.15	0.9		0.75	71
400	BIFA401218	BIFA403218	2	2800	IP55	18°	1.68	1.57	1.44	1.27	1.01		0.75	71
400	BIFA401220	BIFA403220	2	2800	IP55	20°	1.81	1.69	1.55	1.37	1.11		1.1	71
400	BIFA401222	BIFA403222	2	2800	IP55	22°	1.93	1.8	1.65	1.46	1.2		1.1	66
400	BIFA401224	BIFA403224	2	2800	IP55	24°	2.04	1.9	1.74	1.54	1.28		1.1	66
400	BIFA401226	BIFA403226	2	2800	IP55	26°	2.15	2	1.83	1.63	1.37		1.1	67
400	BIFA401228	BIFA403228	2	2800	IP55	28°	2.27	2.11	1.93	1.72	1.45		1.5	68
400	BIFA401230	BIFA403230	2	2800	IP55	30°	2.38	2.22	2.03	1.8	1.52		1.5	68
400	BIFA401232	BIFA403232	2	2800	IP55	32°	2.49	2.31	2.11	1.88	1.59		1.5	68
400	-	BIFA403234	2	2800	IP55	34°	2.59	2.4	2.19	1.94	1.64		2.2	67
400	-	BIFA403236	2	2800	IP55	36°	2.67	2.47	2.25	1.99	1.67		2.2	66
400	-	BIFA403238	2	2800	IP55	38°	2.73	2.53	2.31	2.04	1.69		2.2	66
400	-	BIFA403240	2	2800	IP55	40°	2.78	2.59	2.36	2.08	1.69		3	66

Sound Power Level Spectra dB (ref 10<sup>-12</sup> Watts)

Dia.	1 Phase Stock Ref		3 Phase Stock Ref		Spectrum	dB							dBA @ 3m
	63	125	250	500		1k	2k	4k	8k				
400	BIFA401210	BIFA403210	2	Inlet/Outlet	89	86	89	86	87	84	81	74	71
400	BIFA401212	BIFA403212	2	Inlet/Outlet	89	86	89	86	87	84	81	74	71
400	BIFA401214	BIFA403214	2	Inlet/Outlet	89	86	89	86	87	84	81	74	71
400	BIFA401216	BIFA403216	2	Inlet/Outlet	89	86	89	86	87	84	81	74	71
400	BIFA401218	BIFA403218	2	Inlet/Outlet	89	86	89	86	87	84	81	74	71
400	BIFA401220	BIFA403220	2	Inlet/Outlet	89	86	89	86	87	84	81	74	71
400	BIFA401222	BIFA403222	2	Inlet/Outlet	84	81	84	81	82	79	76	69	66
400	BIFA401224	BIFA403224	2	Inlet/Outlet	84	81	84	81	82	79	76	69	66
400	BIFA401226	BIFA403226	2	Inlet/Outlet	85	82	85	82	83	80	77	70	67
400	BIFA401228	BIFA403228	2	Inlet/Outlet	86	83	86	83	84	81	78	71	68
400	BIFA401230	BIFA403230	2	Inlet/Outlet	86	83	86	83	84	81	78	71	68
400	BIFA401232	BIFA403232	2	Inlet/Outlet	86	83	86	83	84	81	78	71	68
400	-	BIFA403234	2	Inlet/Outlet	85	82	85	82	83	80	77	70	67
400	-	BIFA403236	2	Inlet/Outlet	84	81	84	81	82	79	76	69	66
400	-	BIFA403238	2	Inlet/Outlet	84	81	84	81	82	79	76	69	66
400	-	BIFA403240	2	Inlet/Outlet	84	81	84	81	82	79	76	69	66

## Performance Curve



## Performance Guide

3 Phase			rpm	IP	Curve	m <sup>3</sup> /s at Pa						Motor kW	dBA @3m
Dia.	Stock Ref	Poles				Rating	Ref	0	150	300	450		
450	BIFA453210	2	2880	IP55	10°	1.72	1.57	1.37	1.04	0.56	0.11	1.1	74
450	BIFA453212	2	2880	IP55	12°	1.89	1.74	1.54	1.22	0.73	0.21	1.1	73
450	BIFA453214	2	2880	IP55	14°	2.08	1.91	1.7	1.4	0.9	0.32	1.5	72
450	BIFA453216	2	2880	IP55	16°	2.27	2.1	1.88	1.57			1.5	71
450	BIFA453218	2	2880	IP55	18°	2.47	2.28	2.05	1.74	1.2		1.5	70
450	BIFA453220	2	2880	IP55	20°	2.65	2.46	2.21	1.88	1.35		2.2	70
450	BIFA453222	2	2880	IP55	22°	2.82	2.61	2.35	2.01	1.49		2.2	70
450	BIFA453224	2	2880	IP55	24°	2.99	2.76	2.48	2.13	1.62		2.2	70
450	BIFA453226	2	2880	IP55	26°	3.15	2.91	2.61	2.25	1.75		2.2	70
450	BIFA453228	2	2880	IP55	28°	3.32	3.06	2.75	2.38	1.86		3	70
450	BIFA453230	2	2880	IP55	30°	3.49	3.21	2.89	2.5	1.97		3	70
450	BIFA453232	2	2880	IP55	32°	3.65	3.35	3.01	2.6	2.08		3	70

## Sound Power Level Spectra dB (ref 10<sup>-12</sup> Watts)

Dia.	3 Phase Stock Ref	Poles	Spectrum	dB								dBA @ 3m
				63	125	250	500	1k	2k	4k	8k	
450	BIFA453210	2	Inlet/Outlet	92	89	92	89	90	87	84	77	74
450	BIFA453212	2	Inlet/Outlet	91	88	91	88	89	86	83	76	73
450	BIFA453214	2	Inlet/Outlet	90	87	90	87	88	85	82	75	72
450	BIFA453216	2	Inlet/Outlet	89	86	89	86	87	84	81	74	71
450	BIFA453218	2	Inlet/Outlet	88	85	88	85	86	83	80	73	70
450	BIFA453220	2	Inlet/Outlet	88	85	88	85	86	83	80	73	70
450	BIFA453222	2	Inlet/Outlet	88	85	88	85	86	83	80	73	70
450	BIFA453224	2	Inlet/Outlet	88	85	88	85	86	83	80	73	70
450	BIFA453226	2	Inlet/Outlet	88	85	88	85	86	83	80	73	70
450	BIFA453228	2	Inlet/Outlet	88	85	88	85	86	83	80	73	70
450	BIFA453230	2	Inlet/Outlet	88	85	88	85	86	83	80	73	70
450	BIFA453232	2	Inlet/Outlet	88	85	88	85	86	83	80	73	70

Performance Curve

BIFA50 - 3 Phase - 2 Pole

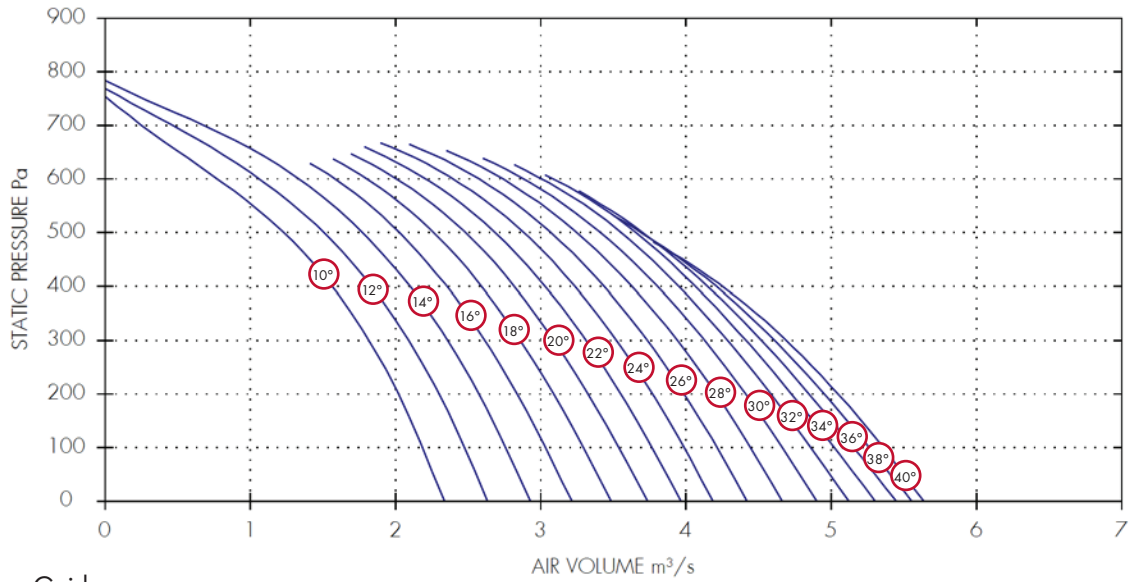

Performance Guide

Dia.	Stock Ref	3 Phase Poles	rpm	IP Rating	Curve Ref	m³/s at Pa						Motor kW	dBA @3m
						0	150	300	450	600	750		
500	BIFA503210	2	2880	IP55	10°	2.34	2.11	1.82	1.41	0.77	0.02	1.5	74
500	BIFA503212	2	2880	IP55	12°	2.64	2.39	2.09	1.68	1.06	0.12	1.5	73
500	BIFA503214	2	2880	IP55	14°	2.93	2.67	2.36	1.95	1.33	0.26	2.2	72
500	BIFA503216	2	2880	IP55	16°	3.21	2.94	2.62	2.2	1.58		2.2	71
500	BIFA503218	2	2880	IP55	18°	3.48	3.19	2.86	2.44	1.8		2.2	71
500	BIFA503220	2	2880	IP55	20°	3.73	3.43	3.09	2.66	2.01		3	71
500	BIFA503222	2	2880	IP55	22°	3.96	3.66	3.31	2.87	2.21		3	71
500	BIFA503224	2	2880	IP55	24°	4.19	3.88	3.52	3.07	2.4		3	71
500	BIFA503226	2	2880	IP55	26°	4.42	4.11	3.73	3.26	2.58		4	71
500	BIFA503228	2	2880	IP55	28°	4.66	4.33	3.94	3.45	2.74		4	72
500	BIFA503230	2	2880	IP55	30°	4.9	4.54	4.13	3.62	2.88		4	72
500	BIFA503232	2	2880	IP55	32°	5.12	4.72	4.28	3.76	3		5.5	72
500	BIFA503234	2	2880	IP55	34°	5.3	4.88	4.41	3.87	3.08		5.5	72
500	BIFA503236	2	2880	IP55	36°	5.45	5	4.52	3.94			5.5	72
500	BIFA503238	2	2880	IP55	38°	5.55	5.11	4.61	3.97			7.5	72
500	BIFA503240	2	2880	IP55	40°	5.64	5.21	4.69	3.98			7.5	72

Sound Power Level Spectra dB (ref 10<sup>-12</sup> Watts)

Dia.	3 Phase Stock Ref	Poles	Spectrum	dB								dBA @ 3m
				63	125	250	500	1k	2k	4k	8k	
500	BIFA503210	2	Inlet/Outlet	93	84	91	91	91	87	85	78	74
500	BIFA503212	2	Inlet/Outlet	92	83	90	90	90	86	84	77	73
500	BIFA503214	2	Inlet/Outlet	91	82	89	89	89	85	83	76	72
500	BIFA503216	2	Inlet/Outlet	90	81	88	88	88	84	82	75	71
500	BIFA503218	2	Inlet/Outlet	90	81	88	88	88	84	82	75	71
500	BIFA503220	2	Inlet/Outlet	90	81	88	88	88	84	82	75	71
500	BIFA503222	2	Inlet/Outlet	90	81	88	88	88	84	82	75	71
500	BIFA503224	2	Inlet/Outlet	90	81	88	88	88	84	82	75	71
500	BIFA503226	2	Inlet/Outlet	90	81	88	88	88	84	82	75	71
500	BIFA503228	2	Inlet/Outlet	91	82	89	89	89	85	83	76	72
500	BIFA503230	2	Inlet/Outlet	91	82	89	89	89	85	83	76	72
500	BIFA503232	2	Inlet/Outlet	91	82	89	89	89	85	83	76	72
500	BIFA503234	2	Inlet/Outlet	91	82	89	89	89	85	83	76	72
500	BIFA503236	2	Inlet/Outlet	91	82	89	89	89	85	83	76	72
500	BIFA503238	2	Inlet/Outlet	91	82	89	89	89	85	83	76	72
500	BIFA503240	2	Inlet/Outlet	91	82	89	89	89	85	83	76	72

Performance Curve

BIFA56 - 3 Phase - 2 Pole

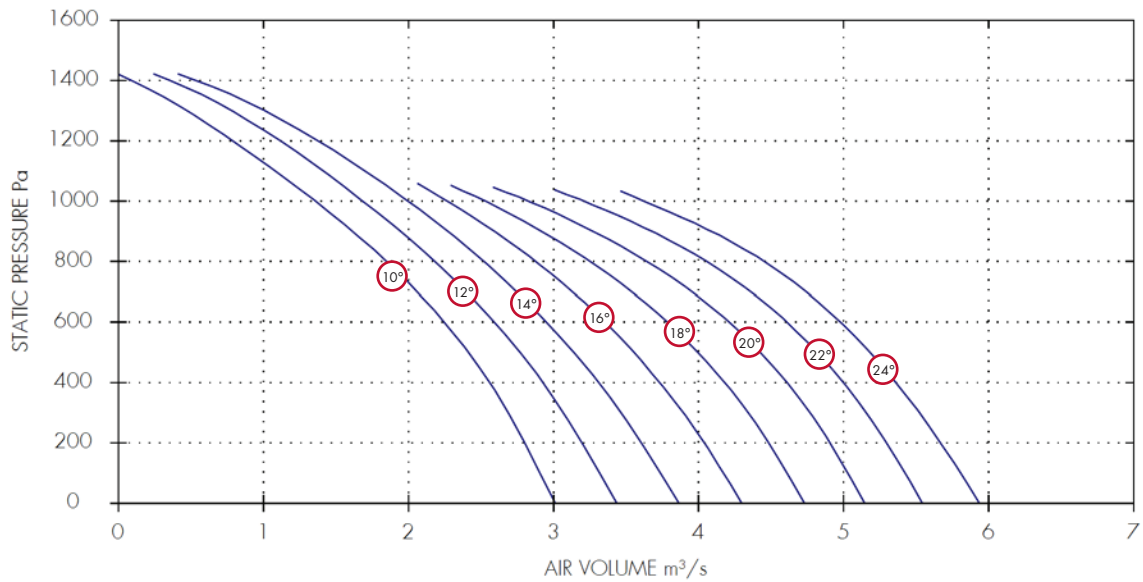

Performance Guide

Dia.	3 Phase Stock Ref	Poles	rpm	IP Rating	Curve Ref	m³/s at Pa								Motor kW	dBA @3m
						0	200	400	600	800	1000	1200	1400		
560	BIFA563210	2	2880	IP55	10°	3.01	2.8	2.56	2.25	1.85	1.36	0.79	0.09	4	79
560	BIFA563212	2	2880	IP55	12°	3.44	3.2	2.93	2.59	2.18	1.69	1.11	0.35	4	79
560	BIFA563214	2	2880	IP55	14°	3.87	3.61	3.31	2.95	2.52	1.99	1.37	0.53	4	79
560	BIFA563216	2	2880	IP55	16°	4.3	4.04	3.73	3.36	2.88	2.27			5.5	79
560	BIFA563218	2	2880	IP55	18°	4.73	4.48	4.18	3.79	3.25	2.53			5.5	79
560	BIFA563220	2	2880	IP55	20°	5.15	4.91	4.61	4.21	3.65	2.83			7.5	79
560	BIFA563222	2	2880	IP55	22°	5.54	5.3	5	4.61	4.05	3.21			7.5	79
560	BIFA563224	2	2880	IP55	24°	5.94	5.67	5.36	4.98	4.45	3.62			7.5	79

Sound Power Level Spectra dB (ref 10<sup>-12</sup> Watts)

Dia.	3 Phase Stock Ref	Poles	Spectrum	dB								dBA @ 3m
				63	125	250	500	1k	2k	4k	8k	
560	BIFA563210	2	Inlet/Outlet	94	89	97	98	94	91	86	82	79
560	BIFA563212	2	Inlet/Outlet	94	89	97	98	94	91	86	82	79
560	BIFA563214	2	Inlet/Outlet	94	89	97	98	94	91	86	82	79
560	BIFA563216	2	Inlet/Outlet	94	89	97	98	94	91	86	82	79
560	BIFA563218	2	Inlet/Outlet	94	89	97	98	94	91	86	82	79
560	BIFA563220	2	Inlet/Outlet	94	89	97	98	94	91	86	82	79
560	BIFA563222	2	Inlet/Outlet	94	89	97	98	94	91	86	82	79
560	BIFA563224	2	Inlet/Outlet	94	89	97	98	94	91	86	82	79

Performance Curve

BIFA63 - 3 Phase - 2 Pole

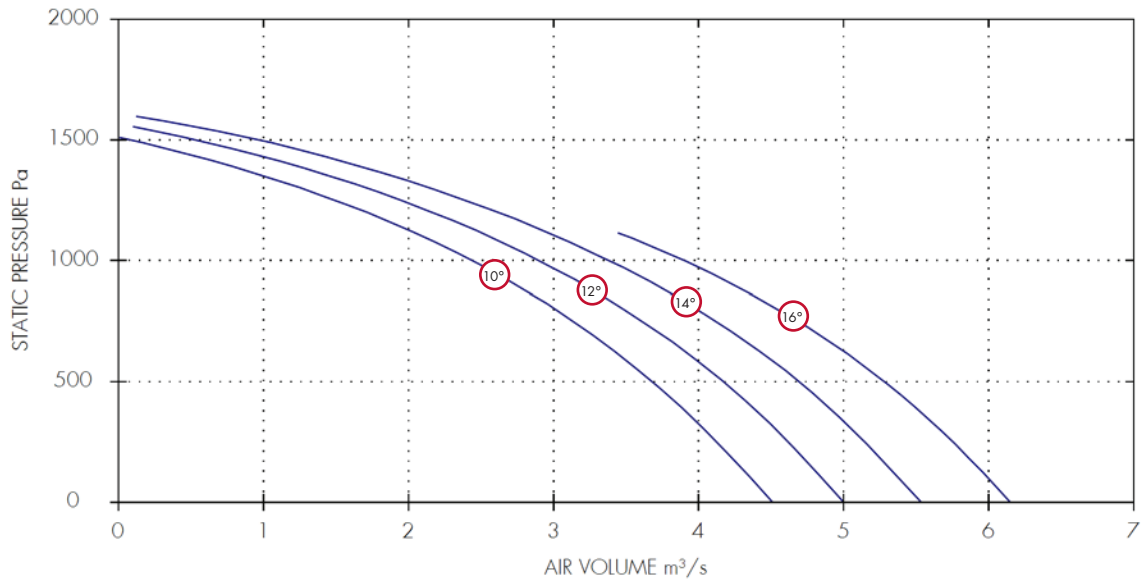

Performance Guide

Dia.	3 Phase Stock Ref	Poles	rpm	IP Rating	Curve Ref	m <sup>3</sup> /s at Pa								Motor kW	dBA @3m
						0	200	400	600	800	1000	1200	1400		
630	BIFA633210	2	2940	IP55	10°	4.51	4.2	3.87	3.47	3.01	2.44	1.7	0.72	5.5	84
630	BIFA633212	2	2940	IP55	12°	5	4.7	4.36	3.96	3.48	2.9	2.16	1.17	5.5	84
630	BIFA633214	2	2940	IP55	14°	5.53	5.22	4.88	4.48	3.98	3.38	2.61	1.6	7.5	84
630	BIFA633216	2	2940	IP55	16°	6.15	5.84	5.48	5.06	4.54	3.89			7.5	84

Sound Power Level Spectra dB (ref 10<sup>-12</sup> Watts)

Dia.	3 Phase Stock Ref	Poles	Spectrum	dB								dBA @ 3m
				63	125	250	500	1k	2k	4k	8k	
630	BIFA633210	2	Inlet/Outlet	99	94	102	103	99	96	91	87	84
630	BIFA633212	2	Inlet/Outlet	99	94	102	103	99	96	91	87	84
630	BIFA633214	2	Inlet/Outlet	99	94	102	103	99	96	91	87	84
630	BIFA633216	2	Inlet/Outlet	99	94	102	103	99	96	91	87	84

## Performance Curve

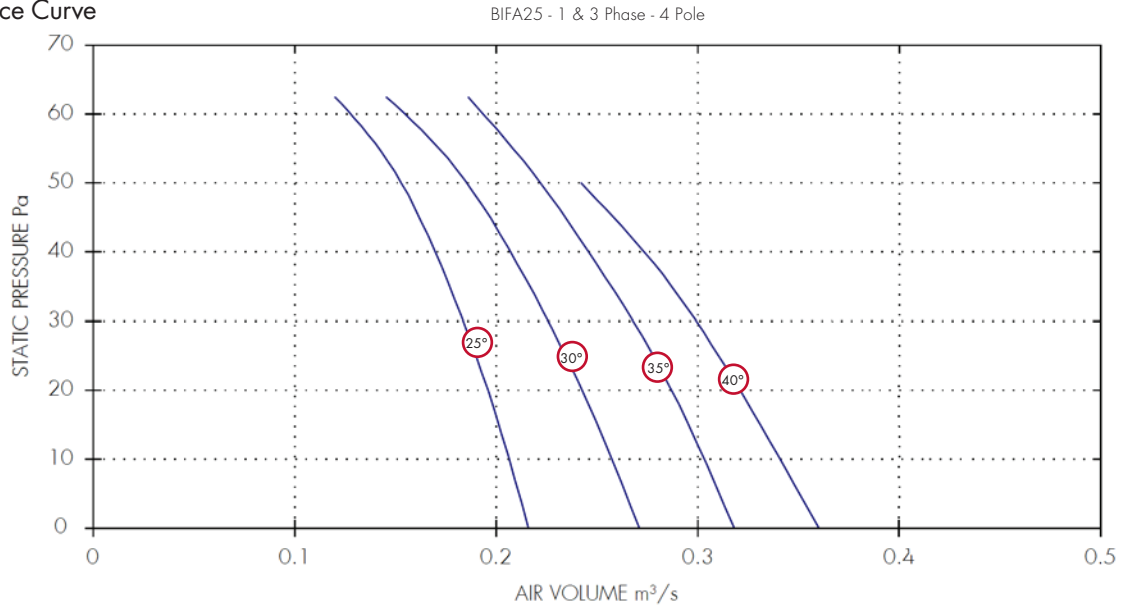

## Performance Guide

Dia.	1 Phase		3 Phase		IP	Curve	m³/s at Pa							Motor	dBA @3m
	Stock Ref	Stock Ref	Poles	rpm			Rating	Ref	0	10	20	30	40		
250	BIFA251425	BIFA253425	4	1400	IP55	25°	0.22	0.21	0.2	0.18	0.17	0.15	0.13	0.25	46
250	BIFA251430	BIFA253430	4	1400	IP55	30°	0.27	0.26	0.24	0.23	0.21	0.19	0.15	0.25	45
250	BIFA251435	BIFA253435	4	1400	IP55	35°	0.32	0.3	0.29	0.27	0.25	0.22	0.19	0.25	46
250	BIFA251440	BIFA253440	4	1400	IP55	40°	0.36	0.34	0.32	0.3	0.27	0.24		0.25	46

## Sound Power Level Spectra dB (ref 10<sup>-12</sup> Watts)

Dia.	1 Phase		3 Phase		Spectrum	dB								dBA @ 3m
	Stock Ref	Stock Ref	Poles	rpm		63	125	250	500	1k	2k	4k	8k	
250	BIFA251425	BIFA253425	4	1400	Inlet/Outlet	61	68	64	63	61	58	55	52	46
250	BIFA251430	BIFA253430	4	1400	Inlet/Outlet	60	67	63	62	60	57	54	51	45
250	BIFA251435	BIFA253435	4	1400	Inlet/Outlet	61	68	64	63	61	58	55	52	46
250	BIFA251440	BIFA253440	4	1400	Inlet/Outlet	61	68	64	63	61	58	55	52	46

Performance Curve

BIFA31 - 1 & 3 Phase - 4 Pole

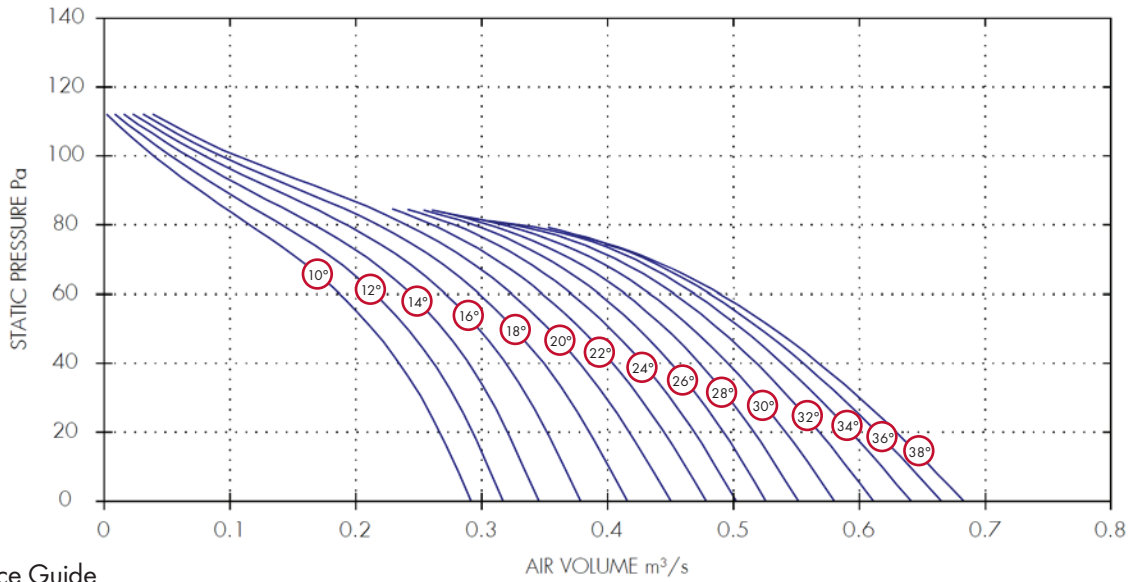

Performance Guide

Dia.	1 Phase		3 Phase		IP	Curve	m³/s at Pa						Motor	dBA @3m
	Stock Ref	Stock Ref	Poles	rpm			Rating	Ref	0	20	40	60		
315	BIFA311410	BIFA313410	4	1400	IP55	10°	0.29	0.27	0.23	0.19	0.12	0.04	0.25	49
315	BIFA311412	BIFA313412	4	1400	IP55	12°	0.32	0.29	0.26	0.22	0.14	0.05	0.25	49
315	BIFA311414	BIFA313414	4	1400	IP55	14°	0.35	0.32	0.29	0.24	0.17	0.07	0.25	49
315	BIFA313416	BIFA313416	4	1400	IP55	16°	0.38	0.35	0.32	0.27	0.19	0.08	0.25	44
315	BIFA311418	BIFA313418	4	1400	IP55	18°	0.42	0.39	0.35	0.3	0.22	0.09	0.25	44
315	BIFA311420	BIFA313420	4	1400	IP55	20°	0.45	0.42	0.38	0.32	0.24	0.11	0.25	44
315	BIFA311422	BIFA313422	4	1400	IP55	22°	0.48	0.45	0.4	0.35	0.26		0.25	44
315	BIFA311424	BIFA313424	4	1400	IP55	24°	0.5	0.47	0.43	0.37	0.28		0.25	46
315	BIFA311426	BIFA313426	4	1400	IP55	26°	0.53	0.49	0.45	0.39	0.29		0.25	46
315	BIFA311428	BIFA313428	4	1400	IP55	28°	0.55	0.52	0.47	0.41	0.31		0.25	46
315	BIFA311430	BIFA313430	4	1400	IP55	30°	0.58	0.54	0.5	0.43	0.32		0.25	46
315	BIFA311432	BIFA313432	4	1400	IP55	32°	0.61	0.57	0.52	0.45	0.32		0.25	48
315	BIFA311434	BIFA313434	4	1400	IP55	34°	0.64	0.59	0.54	0.47	0.33		0.25	48
315	BIFA311436	BIFA313436	4	1400	IP55	36°	0.67	0.61	0.56	0.48			0.25	48
315	BIFA311438	BIFA313438	4	1400	IP55	38°	0.68	0.63	0.57	0.49			0.25	48

Sound Power Level Spectra dB (ref 10<sup>-12</sup> Watts)

Dia.	1 Phase		3 Phase		Spectrum	63	125	250	500	1k	2k	4k	8k	dBA @ 3m
	Stock Ref	Stock Ref	Poles											
315	BIFA311410	BIFA313410	4	Inlet/Outlet	66	69	67	64	65	63	58	48	49	
315	BIFA311412	BIFA313412	4	Inlet/Outlet	66	69	67	64	65	63	58	48	49	
315	BIFA311414	BIFA313414	4	Inlet/Outlet	66	69	67	64	65	63	58	48	49	
315	BIFA313416	BIFA313416	4	Inlet/Outlet	61	64	62	59	60	58	53	43	44	
315	BIFA311418	BIFA313418	4	Inlet/Outlet	61	64	62	59	60	58	53	43	44	
315	BIFA311420	BIFA313420	4	Inlet/Outlet	61	64	62	59	60	58	53	43	44	
315	BIFA311422	BIFA313422	4	Inlet/Outlet	61	64	62	59	60	58	53	43	44	
315	BIFA311424	BIFA313424	4	Inlet/Outlet	63	66	64	61	62	60	55	45	46	
315	BIFA311426	BIFA313426	4	Inlet/Outlet	63	66	64	61	62	60	55	45	46	
315	BIFA311428	BIFA313428	4	Inlet/Outlet	63	66	64	61	62	60	55	45	46	
315	BIFA311430	BIFA313430	4	Inlet/Outlet	63	66	64	61	62	60	55	45	46	
315	BIFA311432	BIFA313432	4	Inlet/Outlet	65	68	66	63	64	62	57	47	48	
315	BIFA311434	BIFA313434	4	Inlet/Outlet	65	68	66	63	64	62	57	47	48	
315	BIFA311436	BIFA313436	4	Inlet/Outlet	65	68	66	63	64	62	57	47	48	
315	BIFA311438	BIFA313438	4	Inlet/Outlet	65	68	66	63	64	62	57	47	48	



Performance Curve

BIFA40 - 1 & 3 Phase - 4 Pole

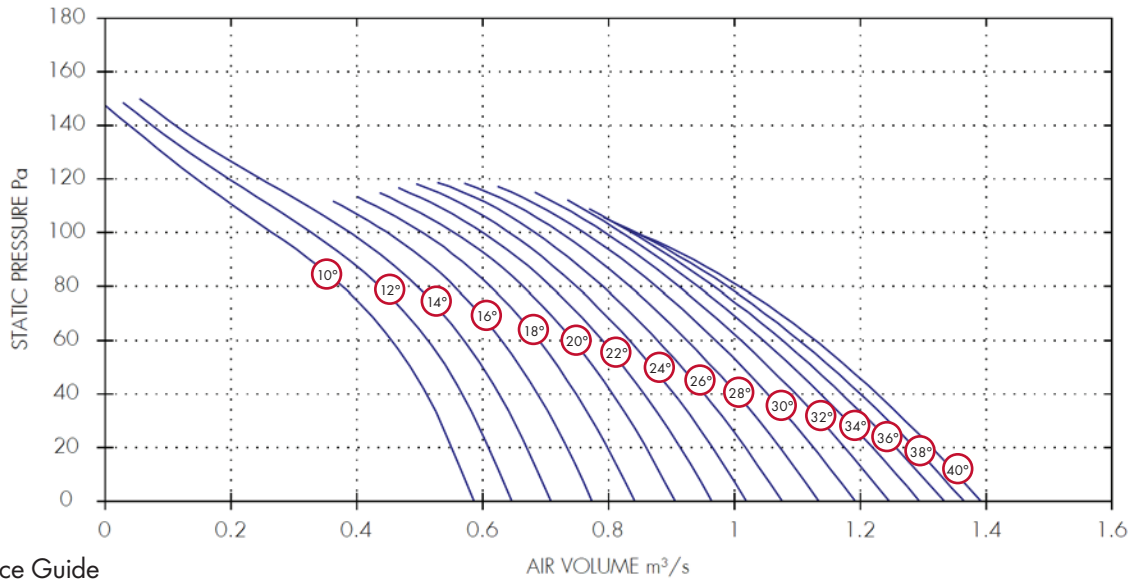

Performance Guide

Dia.	1 Phase		Poles	rpm	IP	Curve Ref	m <sup>3</sup> /s at Pa									Motor kW	dBA @3m
	Stock Ref	Stock Ref					0	20	40	60	80	100	120	140			
400	BIFA401410	BIFA403410	4	1400	IP55	10°	0.59	0.55	0.51	0.46	0.38	0.27	0.15	0.04	0.25	54	
400	BIFA401412	BIFA403412	4	1400	IP55	12°	0.65	0.61	0.57	0.51	0.44	0.33	0.2	0.08	0.25	54	
400	BIFA401414	BIFA403414	4	1400	IP55	14°	0.71	0.67	0.63	0.57	0.5	0.39	0.25	0.11	0.25	54	
400	BIFA401416	BIFA403416	4	1400	IP55	16°	0.77	0.73	0.69	0.63	0.56	0.45			0.25	54	
400	BIFA401418	BIFA403418	4	1400	IP55	18°	0.84	0.8	0.75	0.69	0.61	0.5			0.25	54	
400	BIFA401420	BIFA403420	4	1400	IP55	20°	0.91	0.86	0.81	0.74	0.66	0.55			0.25	54	
400	BIFA401422	BIFA403422	4	1400	IP55	22°	0.96	0.91	0.86	0.79	0.71	0.6			0.25	48	
400	BIFA401424	BIFA403424	4	1400	IP55	24°	1.02	0.97	0.9	0.83	0.75	0.64			0.25	48	
400	BIFA401426	BIFA403426	4	1400	IP55	26°	1.08	1.02	0.95	0.88	0.79	0.68			0.25	50	
400	BIFA401428	BIFA403428	4	1400	IP55	28°	1.13	1.07	1	0.92	0.83	0.72			0.25	51	
400	BIFA401430	BIFA403430	4	1400	IP55	30°	1.19	1.13	1.05	0.97	0.88	0.76			0.25	52	
400	BIFA401432	BIFA403432	4	1400	IP55	32°	1.25	1.18	1.1	1.01	0.91	0.79			0.25	52	
400	BIFA401434	BIFA403434	4	1400	IP55	34°	1.29	1.22	1.14	1.05	0.94	0.82			0.25	51	
400	BIFA401436	BIFA403436	4	1400	IP55	36°	1.33	1.26	1.17	1.08	0.97	0.84			0.25	51	
400	BIFA401438	BIFA403438	4	1400	IP55	38°	1.36	1.29	1.2	1.1	0.99	0.84			0.25	50	
400	BIFA401440	BIFA403440	4	1400	IP55	40°	1.39	1.31	1.23	1.13	1.01	0.84			0.37	50	

Sound Power Level Spectra dB (ref 10<sup>-12</sup> Watts)

Dia.	1 Phase		Poles	Spectrum	dB @ 3m								
	Stock Ref	Stock Ref			63	125	250	500	1k	2k	4k	8k	
400	BIFA401410	BIFA403410	4	Inlet/Outlet	72	74	73	69	70	67	63	54	54
400	BIFA401412	BIFA403412	4	Inlet/Outlet	72	74	73	69	70	67	63	54	54
400	BIFA401414	BIFA403414	4	Inlet/Outlet	72	74	73	69	70	67	63	54	54
400	BIFA401416	BIFA403416	4	Inlet/Outlet	72	74	73	69	70	67	63	54	54
400	BIFA401418	BIFA403418	4	Inlet/Outlet	72	74	73	69	70	67	63	54	54
400	BIFA401420	BIFA403420	4	Inlet/Outlet	72	74	73	69	70	67	63	54	54
400	BIFA401422	BIFA403422	4	Inlet/Outlet	66	68	67	63	64	61	57	48	48
400	BIFA401424	BIFA403424	4	Inlet/Outlet	66	68	67	63	64	61	57	48	48
400	BIFA401426	BIFA403426	4	Inlet/Outlet	68	70	69	65	66	63	59	50	50
400	BIFA401428	BIFA403428	4	Inlet/Outlet	69	71	70	66	67	64	60	51	51
400	BIFA401430	BIFA403430	4	Inlet/Outlet	70	72	71	67	68	65	61	52	52
400	BIFA401432	BIFA403432	4	Inlet/Outlet	70	72	71	67	68	65	61	52	52
400	BIFA401434	BIFA403434	4	Inlet/Outlet	69	71	70	66	67	64	60	51	51
400	BIFA401436	BIFA403436	4	Inlet/Outlet	69	71	70	66	67	64	60	51	51
400	BIFA401438	BIFA403438	4	Inlet/Outlet	68	70	69	65	66	63	59	50	50
400	BIFA401440	BIFA403440	4	Inlet/Outlet	68	70	69	65	66	63	59	50	50

Performance Curve

BIFA45 - 1 & 3 Phase - 4 Pole

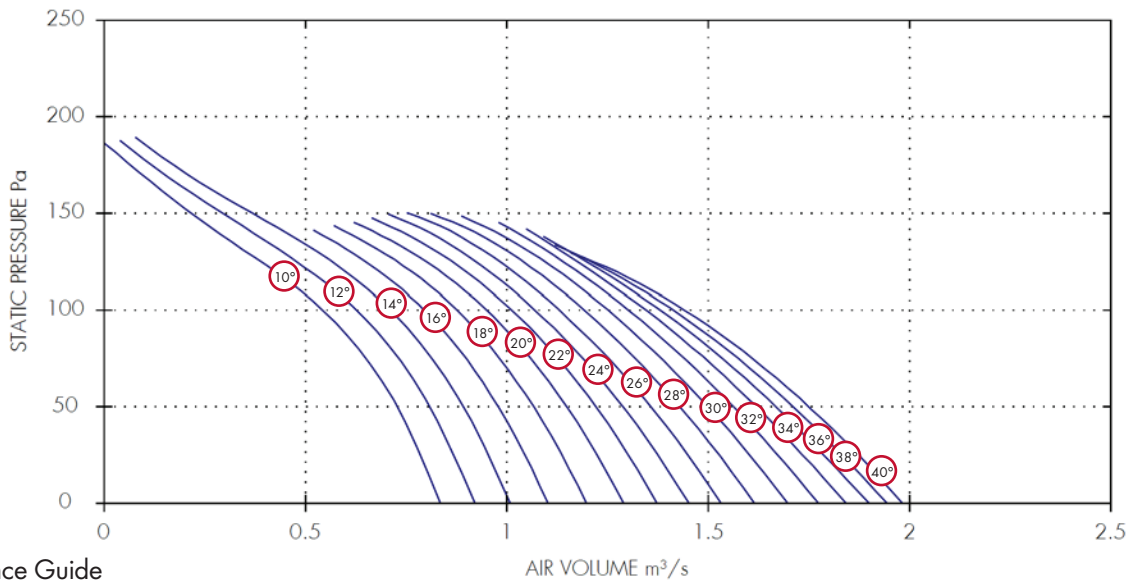

Performance Guide

Dia.	1 Phase		3 Phase		IP	Curve	m³/s at Pa					Motor kW	dBA @3m
	Stock Ref	Stock Ref	Poles	rpm			Rating	Ref	0	40	80		
450	BIFA451410	BIFA453410	4	1400	IP55	10°	0.83	0.75	0.63	0.42	0.15	0.25	59
450	BIFA451412	BIFA453412	4	1400	IP55	12°	0.92	0.83	0.71	0.51	0.22	0.25	59
450	BIFA451414	BIFA453414	4	1400	IP55	14°	1.01	0.92	0.8	0.6	0.28	0.25	59
450	BIFA451416	BIFA453416	4	1400	IP55	16°	1.1	1.01	0.88	0.68		0.25	59
450	BIFA451418	BIFA453418	4	1400	IP55	18°	1.2	1.1	0.96	0.76		0.25	54
450	BIFA451420	BIFA453420	4	1400	IP55	20°	1.29	1.18	1.04	0.83		0.25	55
450	BIFA451422	BIFA453422	4	1400	IP55	22°	1.37	1.25	1.11	0.9		0.25	54
450	BIFA451424	BIFA453424	4	1400	IP55	24°	1.45	1.32	1.17	0.96		0.25	54
450	BIFA451426	BIFA453426	4	1400	IP55	26°	1.53	1.4	1.23	1.01		0.37	54
450	BIFA451428	BIFA453428	4	1400	IP55	28°	1.61	1.47	1.29	1.07		0.37	54
450	BIFA451430	BIFA453430	4	1400	IP55	30°	1.7	1.54	1.36	1.13		0.37	54
450	BIFA451432	BIFA453432	4	1400	IP55	32°	1.77	1.61	1.41	1.17		0.37	54
450	BIFA451434	BIFA453434	4	1400	IP55	34°	1.84	1.67	1.46	1.21		0.55	54
450	BIFA451436	BIFA453436	4	1400	IP55	36°	1.9	1.72	1.51	1.24		0.55	54
450	BIFA451438	BIFA453438	4	1400	IP55	38°	1.94	1.76	1.54	1.25		0.55	54
450	BIFA451440	BIFA453440	4	1400	IP55	40°	1.98	1.8	1.58	1.27		0.55	54

Sound Power Level Spectra dB (ref 10<sup>-12</sup> Watts)

Dia.	1 Phase		3 Phase		Spectrum	dB @ 3m										
	Stock Ref	Stock Ref	Poles	Rating		63	125	250	500	1k	2k	4k	8k	dBA @ 3m		
450	BIFA451410	BIFA453410	4	Inlet/Outlet	77	79	78	74	75	72	68	59	59			
450	BIFA451412	BIFA453412	4	Inlet/Outlet	77	79	78	74	75	72	68	59	59			
450	BIFA451414	BIFA453414	4	Inlet/Outlet	77	79	78	74	75	72	68	59	59			
450	BIFA451416	BIFA453416	4	Inlet/Outlet	77	79	78	74	75	72	68	59	59			
450	BIFA451418	BIFA453418	4	Inlet/Outlet	72	74	73	69	70	67	63	54	54			
450	BIFA451420	BIFA453420	4	Inlet/Outlet	73	75	74	70	71	68	64	55	55			
450	BIFA451422	BIFA453422	4	Inlet/Outlet	72	74	73	69	70	67	63	54	54			
450	BIFA451424	BIFA453424	4	Inlet/Outlet	72	74	73	69	70	67	63	54	54			
450	BIFA451426	BIFA453426	4	Inlet/Outlet	72	74	73	69	70	67	63	54	54			
450	BIFA451428	BIFA453428	4	Inlet/Outlet	72	74	73	69	70	67	63	54	54			
450	BIFA451430	BIFA453430	4	Inlet/Outlet	72	74	73	69	70	67	63	54	54			
450	BIFA451432	BIFA453432	4	Inlet/Outlet	72	74	73	69	70	67	63	54	54			
450	BIFA451434	BIFA453434	4	Inlet/Outlet	72	74	73	69	70	67	63	54	54			
450	BIFA451436	BIFA453436	4	Inlet/Outlet	72	74	73	69	70	67	63	54	54			
450	BIFA451438	BIFA453438	4	Inlet/Outlet	72	74	73	69	70	67	63	54	54			
450	BIFA451440	BIFA453440	4	Inlet/Outlet	72	74	73	69	70	67	63	54	54			

## Performance Curve

BIFA50 - 1 & 3 Phase - 4 Pole

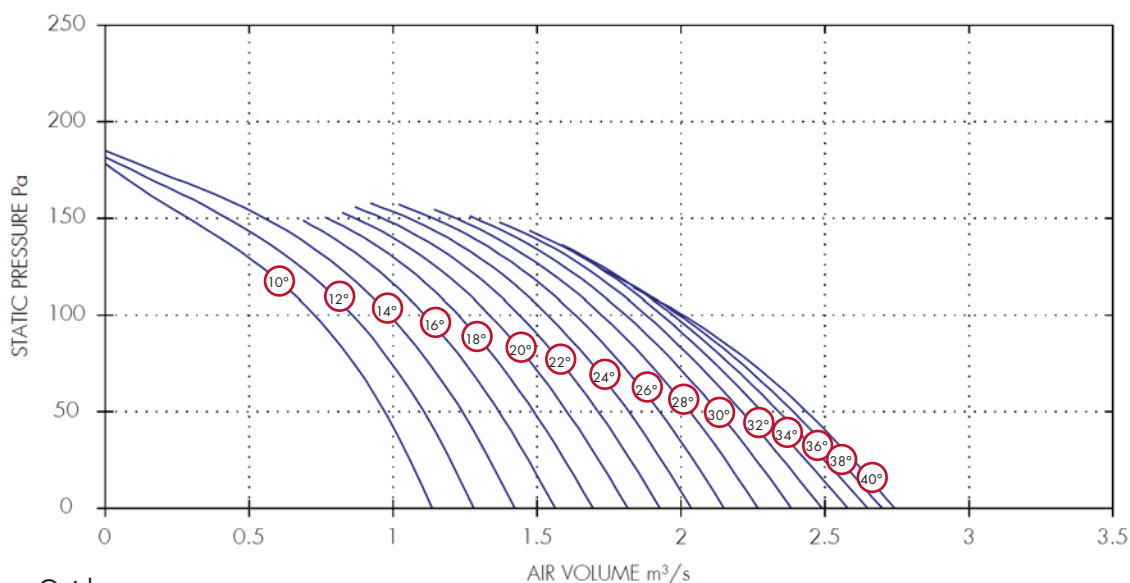

## Performance Guide

Dia.	1 Phase		3 Phase		IP	Curve	m³/s at Pa					Motor	dBA @3m
	Stock Ref	Stock Ref	Poles	rpm			Rating	Ref	0	40	80		
500	BIFA501410	BIFA503410	4	1400	IP55	10°	1.14	1.01	0.84	0.58	0.18	0.25	58
500	BIFA501412	BIFA503412	4	1400	IP55	12°	1.28	1.15	0.97	0.72	0.3	0.25	58
500	BIFA501414	BIFA503414	4	1400	IP55	14°	1.42	1.28	1.1	0.85	0.42	0.25	58
500	BIFA501416	BIFA503416	4	1400	IP55	16°	1.56	1.41	1.22	0.97		0.25	58
500	BIFA501418	BIFA503418	4	1400	IP55	18°	1.69	1.53	1.34	1.09		0.25	58
500	BIFA501420	BIFA503420	4	1400	IP55	20°	1.82	1.65	1.45	1.19		0.37	58
500	BIFA501422	BIFA503422	4	1400	IP55	22°	1.93	1.76	1.56	1.29		0.37	58
500	BIFA501424	BIFA503424	4	1400	IP55	24°	2.04	1.87	1.66	1.39		0.37	58
500	BIFA501426	BIFA503426	4	1400	IP55	26°	2.15	1.97	1.76	1.48		0.37	60
500	BIFA501428	BIFA503428	4	1400	IP55	28°	2.27	2.08	1.86	1.56		0.55	60
500	BIFA501430	BIFA503430	4	1400	IP55	30°	2.38	2.18	1.95	1.64		0.55	61
500	BIFA501432	BIFA503432	4	1400	IP55	32°	2.49	2.27	2.02	1.71		0.55	61
500	BIFA501434	BIFA503434	4	1400	IP55	34°	2.58	2.34	2.08	1.76		0.55	61
500	BIFA501436	BIFA503436	4	1400	IP55	36°	2.65	2.4	2.13	1.78		0.75	61
500	BIFA501438	BIFA503438	4	1400	IP55	38°	2.7	2.46	2.17	1.77		0.75	61
500	BIFA501440	BIFA503440	4	1400	IP55	40°	2.74	2.5	2.2			0.75	61

## Sound Power Level Spectra dB (ref 10<sup>-12</sup> Watts)

Dia.	1 Phase		3 Phase		Poles	Spectrum	dB @ 3m								
	Stock Ref	Stock Ref	Stock Ref	Stock Ref			63	125	250	500	1k	2k	4k	8k	dBA @ 3m
500	BIFA501410	BIFA503410	BIFA503410	BIFA503410	4	Inlet/Outlet	76	78	74	75	74	71	68	58	58
500	BIFA501412	BIFA503412	BIFA503412	BIFA503412	4	Inlet/Outlet	76	78	74	75	74	71	68	58	58
500	BIFA501414	BIFA503414	BIFA503414	BIFA503414	4	Inlet/Outlet	76	78	74	75	74	71	68	58	58
500	BIFA501416	BIFA503416	BIFA503416	BIFA503416	4	Inlet/Outlet	76	78	74	75	74	71	68	58	58
500	BIFA501418	BIFA503418	BIFA503418	BIFA503418	4	Inlet/Outlet	76	78	74	75	74	71	68	58	58
500	BIFA501420	BIFA503420	BIFA503420	BIFA503420	4	Inlet/Outlet	76	78	74	75	74	71	68	58	58
500	BIFA501422	BIFA503422	BIFA503422	BIFA503422	4	Inlet/Outlet	76	78	74	75	74	71	68	58	58
500	BIFA501424	BIFA503424	BIFA503424	BIFA503424	4	Inlet/Outlet	76	78	74	75	74	71	68	58	58
500	BIFA501426	BIFA503426	BIFA503426	BIFA503426	4	Inlet/Outlet	78	80	76	77	76	73	70	60	60
500	BIFA501428	BIFA503428	BIFA503428	BIFA503428	4	Inlet/Outlet	78	80	76	77	76	73	70	60	60
500	BIFA501430	BIFA503430	BIFA503430	BIFA503430	4	Inlet/Outlet	79	81	77	78	77	74	71	61	61
500	BIFA501432	BIFA503432	BIFA503432	BIFA503432	4	Inlet/Outlet	79	81	77	78	77	74	71	61	61
500	BIFA501434	BIFA503434	BIFA503434	BIFA503434	4	Inlet/Outlet	79	81	77	78	77	74	71	61	61
500	BIFA501436	BIFA503436	BIFA503436	BIFA503436	4	Inlet/Outlet	79	81	77	78	77	74	71	61	61
500	BIFA501438	BIFA503438	BIFA503438	BIFA503438	4	Inlet/Outlet	79	81	77	78	77	74	71	61	61
500	BIFA501440	BIFA503440	BIFA503440	BIFA503440	4	Inlet/Outlet	79	81	77	78	77	74	71	61	61

## Performance Curve

BIFA56 - 3 Phase - 4 Pole

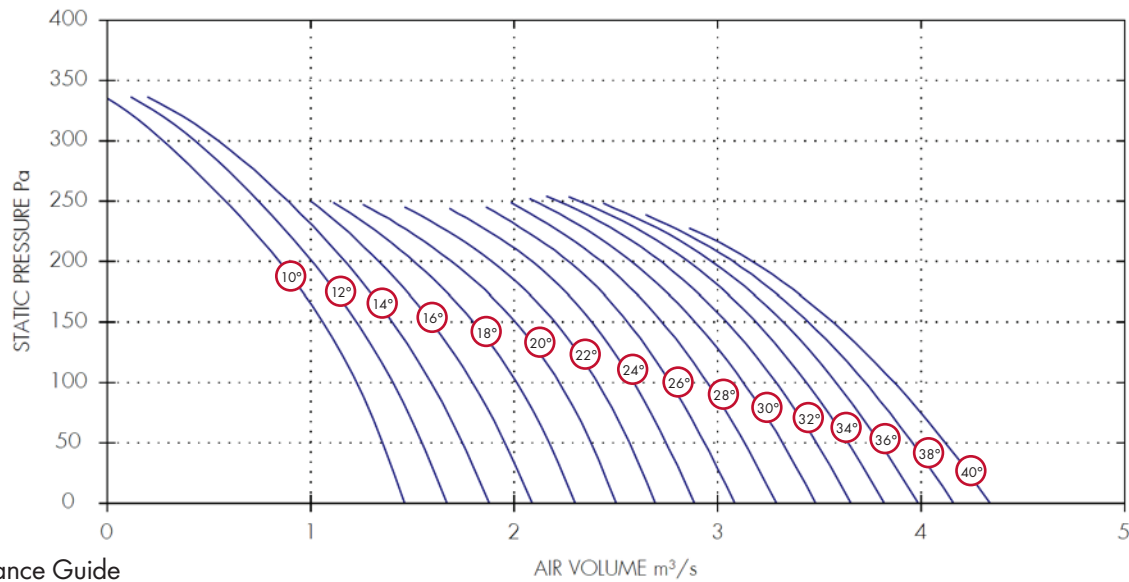

## Performance Guide

Dia.	3 Phase		rpm	IP Rating	Curve Ref	m³/s at Pa							Motor kW	dBA @3m
	Stock Ref	Poles				0	50	100	150	200	250	300		
560	BIFA563410	4	1400	IP55	10°	1.46	1.36	1.23	1.06	0.85	0.58	0.28	0.55	64
560	BIFA563412	4	1400	IP55	12°	1.67	1.55	1.41	1.23	1.01	0.74	0.43	0.55	64
560	BIFA563414	4	1400	IP55	14°	1.88	1.75	1.59	1.4	1.17	0.89	0.55	0.55	64
560	BIFA563416	4	1400	IP55	16°	2.09	1.96	1.8	1.59	1.34			0.55	64
560	BIFA563418	4	1400	IP55	18°	2.3	2.17	2.01	1.8	1.51			0.75	64
560	BIFA563420	4	1400	IP55	20°	2.5	2.38	2.22	2.01	1.69			0.75	64
560	BIFA563422	4	1400	IP55	22°	2.7	2.57	2.41	2.2	1.89			0.75	64
560	BIFA563424	4	1400	IP55	24°	2.89	2.75	2.59	2.38	2.09			1.1	64
560	BIFA563426	4	1400	IP55	26°	3.08	2.94	2.77	2.56	2.27			1.1	64
560	BIFA563428	4	1400	IP55	28°	3.29	3.13	2.95	2.73	2.43			1.1	64
560	BIFA563430	4	1400	IP55	30°	3.48	3.32	3.13	2.89	2.58	2.1		1.1	64
560	BIFA563432	4	1400	IP55	32°	3.66	3.49	3.29	3.04	2.72	2.21		1.5	64
560	BIFA563434	4	1400	IP55	34°	3.82	3.64	3.44	3.19	2.85	2.32		1.5	64
560	BIFA563436	4	1400	IP55	36°	3.99	3.8	3.58	3.32	2.97			1.5	64
560	BIFA563438	4	1400	IP55	38°	4.16	3.96	3.73	3.45	3.08			2.2	64
560	BIFA563440	4	1400	IP55	40°	4.34	4.12	3.87	3.57	3.17			2.2	64

## Sound Power Level Spectra dB (ref 10<sup>-12</sup> Watts)

Dia.	3 Phase		Spectrum	dB								dBA @ 3m
	Stock Ref	Poles		63	125	250	500	1k	2k	4k	8k	
560	BIFA563410	4	Inlet/Outlet	75	75	80	81	81	77	74	64	64
560	BIFA563412	4	Inlet/Outlet	75	75	80	81	81	77	74	64	64
560	BIFA563414	4	Inlet/Outlet	75	75	80	81	81	77	74	64	64
560	BIFA563416	4	Inlet/Outlet	75	75	80	81	81	77	74	64	64
560	BIFA563418	4	Inlet/Outlet	75	75	80	81	81	77	74	64	64
560	BIFA563420	4	Inlet/Outlet	75	75	80	81	81	77	74	64	64
560	BIFA563422	4	Inlet/Outlet	75	75	80	81	81	77	74	64	64
560	BIFA563424	4	Inlet/Outlet	75	75	80	81	81	77	74	64	64
560	BIFA563426	4	Inlet/Outlet	75	75	80	81	81	77	74	64	64
560	BIFA563428	4	Inlet/Outlet	75	75	80	81	81	77	74	64	64
560	BIFA563430	4	Inlet/Outlet	75	75	80	81	81	77	74	64	64
560	BIFA563432	4	Inlet/Outlet	75	75	80	81	81	77	74	64	64
560	BIFA563434	4	Inlet/Outlet	75	75	80	81	81	77	74	64	64
560	BIFA563436	4	Inlet/Outlet	75	75	80	81	81	77	74	64	64
560	BIFA563438	4	Inlet/Outlet	75	75	80	81	81	77	74	64	64
560	BIFA563440	4	Inlet/Outlet	75	75	80	81	81	77	74	64	64

## Performance Curve

BIFA63 - 3 Phase - 4 Pole

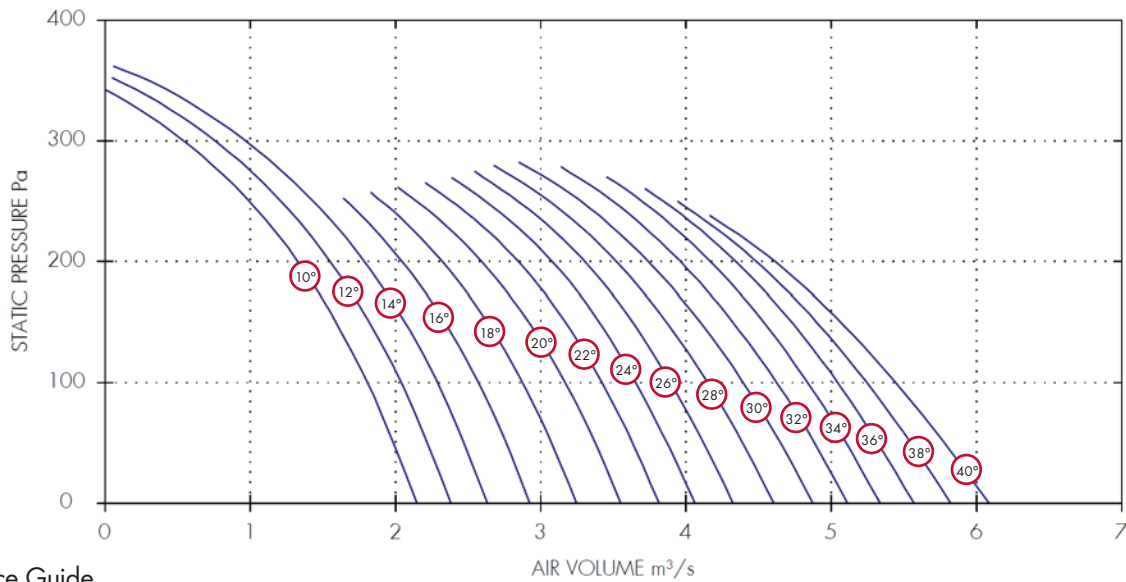

## Performance Guide

Dia.	Stock Ref	Poles	rpm	IP Rating	Curve Ref	m³/s at Pa							Motor kW	dBA @3m	
						0	50	100	150	200	250	300			350
630	BIFA633410	4	1400	IP55	10°	2.15	1.99	1.81	1.59	1.33	0.99	0.54	0.55	64	
630	BIFA633412	4	1400	IP55	12°	2.38	2.22	2.04	1.82	1.55	1.21	0.76	0.09	0.75	64
630	BIFA633414	4	1400	IP55	14°	2.64	2.47	2.29	2.06	1.79	1.43	0.97	0.29	0.75	64
630	BIFA633416	4	1400	IP55	16°	2.93	2.76	2.57	2.34	2.05	1.66			1.1	64
630	BIFA633418	4	1400	IP55	18°	3.24	3.08	2.88	2.63	2.32	1.9			1.1	64
630	BIFA633420	4	1400	IP55	20°	3.55	3.37	3.17	2.92	2.59	2.14			1.1	64
630	BIFA633422	4	1400	IP55	22°	3.82	3.63	3.42	3.17	2.85	2.38			1.5	65
630	BIFA633424	4	1400	IP55	24°	4.06	3.87	3.66	3.4	3.08	2.62			1.5	65
630	BIFA633426	4	1400	IP55	26°	4.32	4.12	3.9	3.63	3.3	2.84			1.5	65
630	BIFA633428	4	1400	IP55	28°	4.61	4.39	4.15	3.87	3.52	3.06			2.2	65
630	BIFA633430	4	1400	IP55	30°	4.88	4.65	4.4	4.1	3.74	3.27			2.2	65
630	BIFA633432	4	1400	IP55	32°	5.11	4.89	4.63	4.32	3.96	3.5			2.2	65
630	BIFA633434	4	1400	IP55	34°	5.34	5.1	4.84	4.54	4.17	3.7			2.2	65
630	BIFA633436	4	1400	IP55	36°	5.57	5.32	5.04	4.73	4.34	3.84			3	65
630	BIFA633438	4	1400	IP55	38°	5.82	5.55	5.25	4.9	4.48				3	65
630	BIFA633440	4	1400	IP55	40°	6.09	5.78	5.44	5.06	4.61				3	65

## Sound Power Level Spectra dB (ref 10<sup>-12</sup> Watts)

Dia.	3 Phase Stock Ref	Poles	Spectrum	dB								dBA @ 3m
				63	125	250	500	1k	2k	4k	8k	
630	BIFA633410	4	Inlet/Outlet	75	71	79	82	81	77	74	66	64
630	BIFA633412	4	Inlet/Outlet	75	71	79	82	81	77	74	66	64
630	BIFA633414	4	Inlet/Outlet	75	71	79	82	81	77	74	66	64
630	BIFA633416	4	Inlet/Outlet	75	71	79	82	81	77	74	66	64
630	BIFA633418	4	Inlet/Outlet	75	71	79	82	81	77	74	66	64
630	BIFA633420	4	Inlet/Outlet	75	71	79	82	81	77	74	66	64
630	BIFA633422	4	Inlet/Outlet	76	72	80	83	82	78	75	67	65
630	BIFA633424	4	Inlet/Outlet	76	72	80	83	82	78	75	67	65
630	BIFA633426	4	Inlet/Outlet	76	72	80	83	82	78	75	67	65
630	BIFA633428	4	Inlet/Outlet	76	72	80	83	82	78	75	67	65
630	BIFA633430	4	Inlet/Outlet	76	72	80	83	82	78	75	67	65
630	BIFA633432	4	Inlet/Outlet	76	72	80	83	82	78	75	67	65
630	BIFA633434	4	Inlet/Outlet	76	72	80	83	82	78	75	67	65
630	BIFA633436	4	Inlet/Outlet	76	72	80	83	82	78	75	67	65
630	BIFA633438	4	Inlet/Outlet	76	72	80	83	82	78	75	67	65
630	BIFA633440	4	Inlet/Outlet	76	72	80	83	82	78	75	67	65

Performance Curve

BIFA71 - 3 Phase - 4 Pole

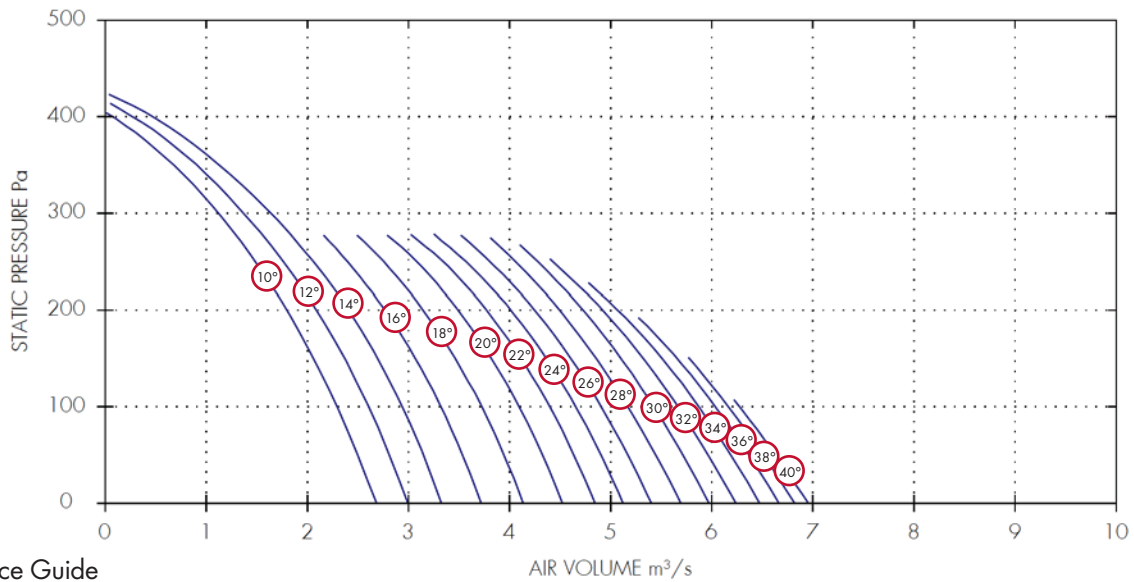

Performance Guide

Dia.	3 Phase			IP	Curve Ref	m³/s at Pa										Motor kW	dBA @3m
	Stock Ref	Poles	rpm			Rating	0	50	100	150	200	250	300	350	400		
710	BIFA713410	4	1420	IP55	10°	2.68	2.5	2.3	2.06	1.8	1.49	1.12	0.68	0.07	0.75	74	
710	BIFA713412	4	1420	IP55	12°	2.99	2.81	2.61	2.37	2.09	1.76	1.37	0.9	0.27	1.1	74	
710	BIFA713414	4	1420	IP55	14°	3.33	3.15	2.94	2.7	2.41	2.06	1.64	1.13	0.47	1.1	74	
710	BIFA713416	4	1420	IP55	16°	3.72	3.53	3.32	3.07	2.77	2.4				1.5	74	
710	BIFA713418	4	1420	IP55	18°	4.14	3.95	3.73	3.46	3.15	2.76				1.5	74	
710	BIFA713420	4	1420	IP55	20°	4.53	4.33	4.1	3.82	3.49	3.08				2.2	71	
710	BIFA713422	4	1420	IP55	22°	4.84	4.64	4.4	4.12	3.77	3.34				2.2	71	
710	BIFA713424	4	1420	IP55	24°	5.12	4.9	4.66	4.36	4.01	3.57				2.2	71	
710	BIFA713426	4	1420	IP55	26°	5.4	5.17	4.91	4.61	4.25	3.81				3	71	
710	BIFA713428	4	1420	IP55	28°	5.69	5.45	5.17	4.86	4.49	4.06				3	71	
710	BIFA713430	4	1420	IP55	30°	5.98	5.71	5.43	5.1	4.73	4.28				3	71	
710	BIFA713432	4	1420	IP55	32°	6.24	5.97	5.67	5.32	4.92	4.42				4	71	
710	BIFA713434	4	1420	IP55	34°	6.47	6.19	5.87	5.51	5.07					4	71	
710	BIFA713436	4	1420	IP55	36°	6.67	6.37	6.04	5.66						4	71	
710	BIFA713438	4	1420	IP55	38°	6.82	6.51	6.17	5.78						5.5	71	
710	BIFA713440	4	1420	IP55	40°	6.96	6.63	6.28							5.5	71	

Sound Power Level Spectra dB (ref 10<sup>-12</sup> Watts)

Dia.	3 Phase			Spectrum	dB @ 3m							
	Stock Ref	Poles	Rating		63	125	250	500	1k	2k	4k	8k
710	BIFA713410	4	Inlet/Outlet	89	84	92	92	90	85	82	75	74
710	BIFA713412	4	Inlet/Outlet	89	84	92	92	90	85	82	75	74
710	BIFA713414	4	Inlet/Outlet	89	84	92	92	90	85	82	75	74
710	BIFA713416	4	Inlet/Outlet	89	84	92	92	90	85	82	75	74
710	BIFA713418	4	Inlet/Outlet	89	84	92	92	90	85	82	75	74
710	BIFA713420	4	Inlet/Outlet	86	81	89	89	87	82	79	72	71
710	BIFA713422	4	Inlet/Outlet	86	81	89	89	87	82	79	72	71
710	BIFA713424	4	Inlet/Outlet	86	81	89	89	87	82	79	72	71
710	BIFA713426	4	Inlet/Outlet	86	81	89	89	87	82	79	72	71
710	BIFA713428	4	Inlet/Outlet	86	81	89	89	87	82	79	72	71
710	BIFA713430	4	Inlet/Outlet	86	81	89	89	87	82	79	72	71
710	BIFA713432	4	Inlet/Outlet	86	81	89	89	87	82	79	72	71
710	BIFA713434	4	Inlet/Outlet	86	81	89	89	87	82	79	72	71
710	BIFA713436	4	Inlet/Outlet	86	81	89	89	87	82	79	72	71
710	BIFA713438	4	Inlet/Outlet	86	81	89	89	87	82	79	72	71
710	BIFA713440	4	Inlet/Outlet	86	81	89	89	87	82	79	72	71

Performance Curve

BIFA80 - 3 Phase - 4 Pole

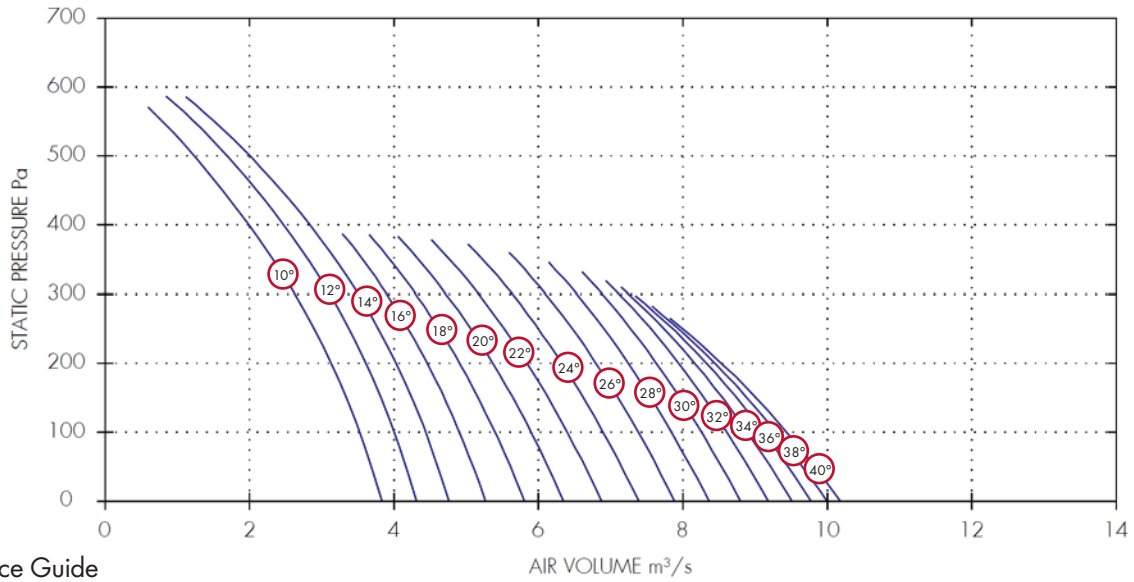

Performance Guide

Dia.	3 Phase		rpm	IP Rating	Curve Ref	m³/s at Pa						Motor kW	dBA @3m
	Stock Ref	Poles				0	100	200	300	400	500		
800	BIFA803410	4	1420	IP55	10°	3.84	3.53	3.13	2.63	1.99	1.24	2.2	80
800	BIFA803412	4	1440	IP55	12°	4.32	4	3.61	3.11	2.47	1.69	2.2	80
800	BIFA803414	4	1440	IP55	14°	4.76	4.44	4.03	3.51	2.84	2	3	80
800	BIFA803416	4	1440	IP55	16°	5.27	4.91	4.46	3.9			3	80
800	BIFA803418	4	1440	IP55	18°	5.81	5.4	4.91	4.3			3	80
800	BIFA803420	4	1440	IP55	20°	6.35	5.9	5.37	4.72			3	77
800	BIFA803422	4	1440	IP55	22°	6.88	6.4	5.84	5.17			4	78
800	BIFA803424	4	1440	IP55	24°	7.39	6.9	6.33	5.64			4	78
800	BIFA803426	4	1440	IP55	26°	7.89	7.38	6.8	6.1			5.5	78
800	BIFA803428	4	1440	IP55	28°	8.36	7.84	7.25	6.53			5.5	79
800	BIFA803430	4	1440	IP55	30°	8.8	8.26	7.64	6.89			7.5	79
800	BIFA803432	4	1440	IP55	32°	9.19	8.61	7.94	7.12			7.5	79
800	BIFA803434	4	1440	IP55	34°	9.51	8.9	8.17	7.25			7.5	79
800	BIFA803436	4	1440	IP55	36°	9.78	9.12	8.33				11	79
800	BIFA803438	4	1440	IP55	38°	9.99	9.29	8.44				11	79
800	BIFA803440	4	1440	IP55	40°	10.18	9.44	8.54				11	79

Sound Power Level Spectra dB (ref 10<sup>-12</sup> Watts)

Dia.	3 Phase		Spectrum	dB								
	Stock Ref	Poles		63	125	250	500	1k	2k	4k	8k	dBA @ 3m
800	BIFA803410	4	Inlet/Outlet	93	87	93	98	96	93	88	80	80
800	BIFA803412	4	Inlet/Outlet	93	87	93	98	96	93	88	80	80
800	BIFA803414	4	Inlet/Outlet	93	87	93	98	96	93	88	80	80
800	BIFA803416	4	Inlet/Outlet	93	87	93	98	96	93	88	80	80
800	BIFA803418	4	Inlet/Outlet	93	87	93	98	96	93	88	80	80
800	BIFA803420	4	Inlet/Outlet	90	84	90	95	93	90	85	77	77
800	BIFA803422	4	Inlet/Outlet	91	85	91	96	94	91	86	78	78
800	BIFA803424	4	Inlet/Outlet	91	85	91	96	94	91	86	78	78
800	BIFA803426	4	Inlet/Outlet	91	85	91	96	94	91	86	78	78
800	BIFA803428	4	Inlet/Outlet	92	86	92	97	95	92	87	79	79
800	BIFA803430	4	Inlet/Outlet	92	86	92	97	95	92	87	79	79
800	BIFA803432	4	Inlet/Outlet	92	86	92	97	95	92	87	79	79
800	BIFA803434	4	Inlet/Outlet	92	86	92	97	95	92	87	79	79
800	BIFA803436	4	Inlet/Outlet	92	86	92	97	95	92	87	79	79
800	BIFA803438	4	Inlet/Outlet	92	86	92	97	95	92	87	79	79
800	BIFA803440	4	Inlet/Outlet	92	86	92	97	95	92	87	79	79



Performance Curve

BIFA90 - 3 Phase - 4 Pole

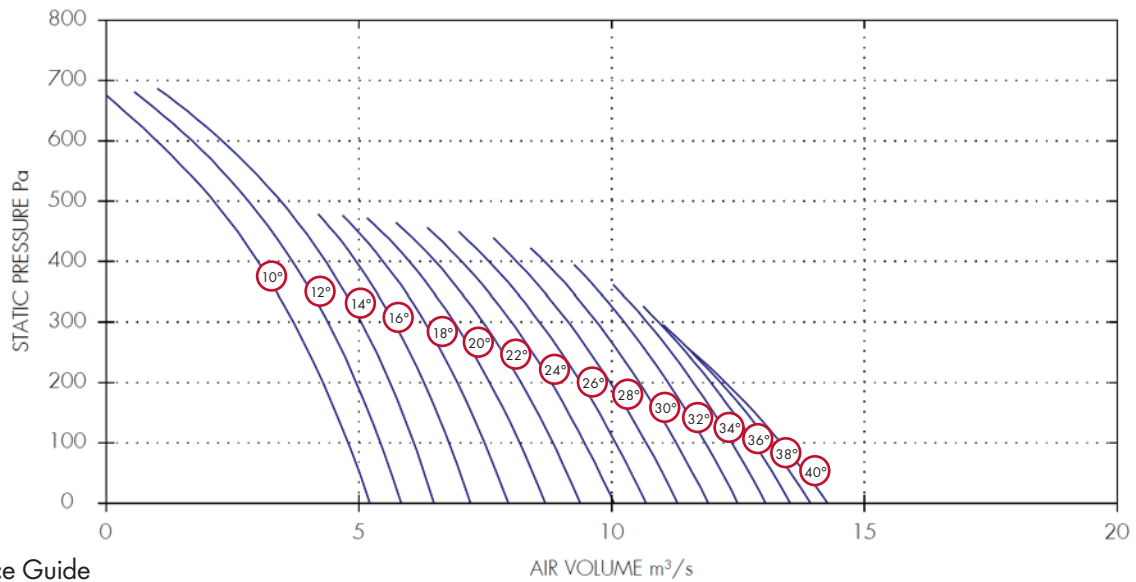

Performance Guide

Dia.	3 Phase			IP Rating	Curve Ref	m³/s at Pa							Motor kW	dBA @3m
	Stock Ref	Poles	rpm			0	100	200	300	400	500	600		
900	BIFA903410	4	1440	IP55	10°	5.22	4.79	4.29	3.71	3	2.12	1	3	79
900	BIFA903412	4	1440	IP55	12°	5.84	5.43	4.95	4.38	3.69	2.82	1.7	4	80
900	BIFA903414	4	1440	IP55	14°	6.49	6.09	5.62	5.05	4.34	3.45	2.29	4	80
900	BIFA903416	4	1440	IP55	16°	7.21	6.79	6.29	5.69	4.94			4	80
900	BIFA903418	4	1440	IP55	18°	7.96	7.49	6.95	6.3	5.49			5.5	81
900	BIFA903420	4	1440	IP55	20°	8.69	8.18	7.59	6.89	6			5.5	81
900	BIFA903422	4	1440	IP55	22°	9.39	8.84	8.21	7.46	6.51			7.5	81
900	BIFA903424	4	1440	IP55	24°	10.04	9.47	8.81	8.02	7.04			7.5	81
900	BIFA903426	4	1440	IP55	26°	10.69	10.08	9.39	8.58	7.57			7.5	82
900	BIFA903428	4	1440	IP55	28°	11.31	10.69	9.97	9.14	8.12			11	82
900	BIFA903430	4	1440	IP55	30°	11.91	11.28	10.55	9.71	8.67			11	82
900	BIFA903432	4	1440	IP55	32°	12.5	11.85	11.12	10.26				11	82
900	BIFA903434	4	1440	IP55	34°	13.05	12.39	11.62	10.7				15	82
900	BIFA903436	4	1440	IP55	36°	13.54	12.82	11.97	10.93				15	82
900	BIFA903438	4	1440	IP55	38°	13.94	13.13	12.15					15	82
900	BIFA903440	4	1440	IP55	40°	14.27	13.36	12.26					15	82

Sound Power Level Spectra dB (ref 10<sup>-12</sup> Watts)

Dia.	3 Phase Stock Ref	Poles	Spectrum	dB								dBA @ 3m
				63	125	250	500	1k	2k	4k	8k	
900	BIFA903410	4	Inlet/Outlet	89	83	91	97	95	92	87	79	79
900	BIFA903412	4	Inlet/Outlet	90	84	92	98	96	93	88	80	80
900	BIFA903414	4	Inlet/Outlet	90	84	92	98	96	93	88	80	80
900	BIFA903416	4	Inlet/Outlet	90	84	92	98	96	93	88	80	80
900	BIFA903418	4	Inlet/Outlet	91	85	93	99	97	94	89	81	81
900	BIFA903420	4	Inlet/Outlet	91	85	93	99	97	94	89	81	81
900	BIFA903422	4	Inlet/Outlet	91	85	93	99	97	94	89	81	81
900	BIFA903424	4	Inlet/Outlet	91	85	93	99	97	94	89	81	81
900	BIFA903426	4	Inlet/Outlet	92	86	94	100	98	95	90	82	82
900	BIFA903428	4	Inlet/Outlet	92	86	94	100	98	95	90	82	82
900	BIFA903430	4	Inlet/Outlet	92	86	94	100	98	95	90	82	82
900	BIFA903432	4	Inlet/Outlet	92	86	94	100	98	95	90	82	82
900	BIFA903434	4	Inlet/Outlet	92	86	94	100	98	95	90	82	82
900	BIFA903436	4	Inlet/Outlet	92	86	94	100	98	95	90	82	82
900	BIFA903438	4	Inlet/Outlet	92	86	94	100	98	95	90	82	82
900	BIFA903440	4	Inlet/Outlet	92	86	94	100	98	95	90	82	82

Performance Curve

BIFA100 - 3 Phase - 4 Pole

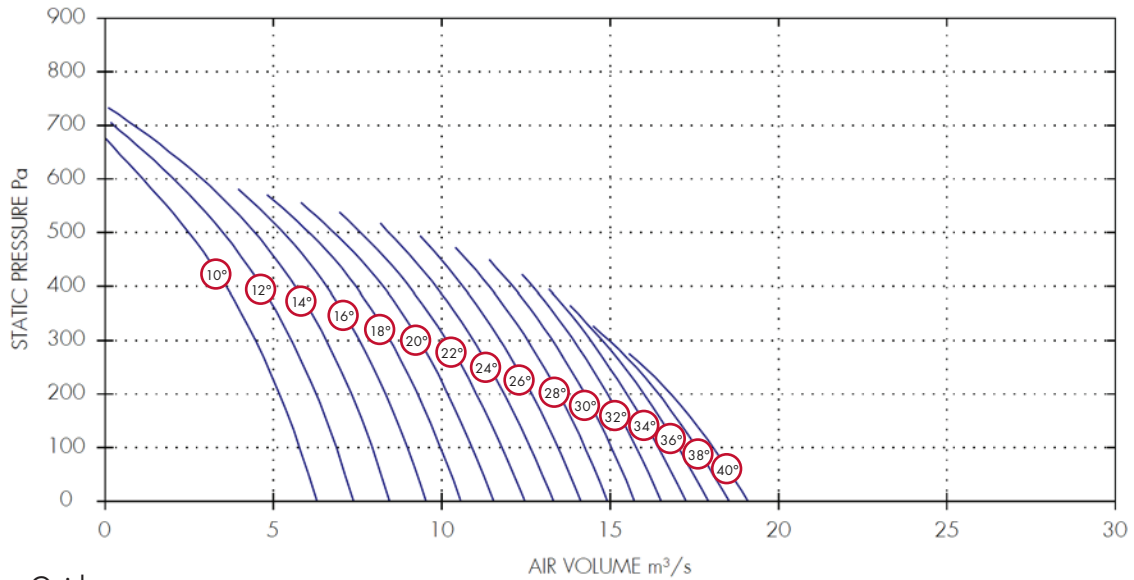

Performance Guide

Dia.	3 Phase		rpm	IP Rating	Curve Ref	m³/s at Pa							Motor kW	dBA @3m	
	Stock Ref	Poles				0	100	200	300	400	500	600			700
1000	BIFA1003410	4	1440	IP55	10°	6.3	5.78	5.18	4.47	3.6	2.49	1.12	4	89	
1000	BIFA1003412	4	1440	IP55	12°	7.38	6.87	6.27	5.54	4.64	3.5	2.04	0.26	4	89
1000	BIFA1003414	4	1440	IP55	14°	8.46	7.94	7.33	6.57	5.64	4.45	2.88	0.86	5.5	89
1000	BIFA1003416	4	1440	IP55	16°	9.54	8.98	8.33	7.55	6.58	5.3			5.5	89
1000	BIFA1003418	4	1440	IP55	18°	10.57	9.97	9.29	8.47	7.45	6.06			7.5	89
1000	BIFA1003420	4	1440	IP55	20°	11.55	10.91	10.19	9.33	8.26	6.8			7.5	89
1000	BIFA1003422	4	1440	IP55	22°	12.46	11.79	11.04	10.15	9.04	7.59			7.5	89
1000	BIFA1003424	4	1440	IP55	24°	13.32	12.64	11.86	10.94	9.82	8.44			11	89
1000	BIFA1003426	4	1440	IP55	26°	14.13	13.45	12.67	11.75	10.63				11	89
1000	BIFA1003428	4	1440	IP55	28°	14.93	14.26	13.48	12.55	11.41				15	89
1000	BIFA1003430	4	1440	IP55	30°	15.73	15.05	14.25	13.29	12.11				15	89
1000	BIFA1003432	4	1440	IP55	32°	16.52	15.78	14.92	13.91	12.7				15	89
1000	BIFA1003434	4	1440	IP55	34°	17.26	16.44	15.5	14.42					18.5	89
1000	BIFA1003436	4	1440	IP55	36°	17.92	17.03	16.01	14.77					18.5	89
1000	BIFA1003438	4	1440	IP55	38°	18.53	17.57	16.44	14.97					18.5	89
1000	BIFA1003440	4	1440	IP55	40°	19.1	18.06	16.8						22	89

Sound Power Level Spectra dB (ref 10<sup>-12</sup> Watts)

Dia.	3 Phase		Spectrum	dB							dBA @ 3m	
	Stock Ref	Poles		63	125	250	500	1k	2k	4k		8k
1000	BIFA1003410	4	Inlet/Outlet	99	94	101	106	106	102	97	89	89
1000	BIFA1003412	4	Inlet/Outlet	99	94	101	106	106	102	97	89	89
1000	BIFA1003414	4	Inlet/Outlet	99	94	101	106	106	102	97	89	89
1000	BIFA1003416	4	Inlet/Outlet	99	94	101	106	106	102	97	89	89
1000	BIFA1003418	4	Inlet/Outlet	99	94	101	106	106	102	97	89	89
1000	BIFA1003420	4	Inlet/Outlet	99	94	101	106	106	102	97	89	89
1000	BIFA1003422	4	Inlet/Outlet	99	94	101	106	106	102	97	89	89
1000	BIFA1003424	4	Inlet/Outlet	99	94	101	106	106	102	97	89	89
1000	BIFA1003426	4	Inlet/Outlet	99	94	101	106	106	102	97	89	89
1000	BIFA1003428	4	Inlet/Outlet	99	94	101	106	106	102	97	89	89
1000	BIFA1003430	4	Inlet/Outlet	99	94	101	106	106	102	97	89	89
1000	BIFA1003432	4	Inlet/Outlet	99	94	101	106	106	102	97	89	89
1000	BIFA1003434	4	Inlet/Outlet	99	94	101	106	106	102	97	89	89
1000	BIFA1003436	4	Inlet/Outlet	99	94	101	106	106	102	97	89	89
1000	BIFA1003438	4	Inlet/Outlet	99	94	101	106	106	102	97	89	89
1000	BIFA1003440	4	Inlet/Outlet	99	94	101	106	106	102	97	89	89

# Electrical Details

## 1 Phase 2 Pole

Stock Ref	rpm	Pitch Angle	Motor kW	S.C. Amps	FLC Amps	Starting Method	Starter Ref	Overload Ref	Transform Controller	*eDemand Controller		
										Voltage Control	1/3 Phase Inverter	3 Phase Inverter
BIFA25	2800	25°-50°	0.37	8	2.6	D.O.L	444744	444702	-	-	-	-
BIFA31	2800	10°-24°	0.37	8	2.6	D.O.L	444744	444702	-	-	-	-
BIFA31	2800	26°-32°	0.55	14	3.6	D.O.L	444744	444703	-	-	-	-
BIFA31	2800	34°-38°	0.75	16	4.5	D.O.L	444744	444703	-	-	-	-
BIFA31	2800	40°	1.1	23	6.6	D.O.L	444744	444704	-	-	-	-
BIFA40	2800	10°-18°	0.75	16	4.5	D.O.L	444744	444703	-	-	-	-
BIFA40	2800	20°-24°	1.1	23	6.6	D.O.L	444744	444704	-	-	-	-
BIFA40	2800	26°-32°	1.5	31	8.5	D.O.L	444744	444705	-	-	-	-

\*1 phase 2 pole are not speed controllable

## 3 Phase 2 Pole

Stock Ref	rpm	Pitch Angle	Motor kW	S.C. Amps	FLC Amps	Starting Method	Starter Ref	Overload Ref	Transform Controller	eDemand Controller		
										Voltage Control	3 Phase Inverter	
BIFA25	2800	25°-50°	0.37	5.82	0.97	D.O.L	444747	444700	-	-	-	444172
BIFA31	2800	10°-24°	0.37	5.82	0.97	D.O.L	444747	444700	-	-	-	444172
BIFA31	2800	26°-32°	0.55	8.52	1.42	D.O.L	444747	444701	-	-	-	444172
BIFA31	2800	34°-38°	0.75	10.62	1.77	D.O.L	444747	444701	-	-	-	444172
BIFA31	2800	40°	1.1	15.06	2.51	D.O.L	444747	444702	-	-	-	444173
BIFA40	2800	10°-18°	0.75	10.62	1.77	D.O.L	444747	444701	-	-	-	444172
BIFA40	2800	20°-26°	1.1	15.06	2.51	D.O.L	444747	444702	-	-	-	444173
BIFA40	2800	28°-32°	1.5	19.68	3.28	D.O.L	444747	444702	-	-	-	444173
BIFA40	2800	34°-38°	2.2	27.66	4.61	D.O.L	444747	444703	-	-	-	444174
BIFA40	2800	40°	3	42.2	6.03	D.O.L	444747	444704	-	-	-	444174
BIFA45	2880	10°-12°	1.1	15.06	2.51	D.O.L	444747	444702	-	-	-	444173
BIFA45	2880	14°-18°	1.5	19.68	3.28	D.O.L	444747	444702	-	-	-	444173
BIFA45	2880	20°-26°	2.2	27.66	4.61	D.O.L	444747	444703	-	-	-	444174
BIFA45	2880	28°-32°	3	42.2	6.03	D.O.L	444747	444704	-	-	-	444174
BIFA50	2880	10°-12°	1.5	19.68	3.28	D.O.L	444747	444702	-	-	-	444173
BIFA50	2880	14°-18°	2.2	27.66	4.61	D.O.L	444747	444703	-	-	-	444174
BIFA50	2880	20°-24°	3	42.2	6.03	D.O.L	444747	444704	-	-	-	444174
BIFA50	2880	26°-30°	4	59.1	7.88	D.O.L	444747	444705	-	-	-	444175
BIFA50	2880	32°-36°	5.5	78.8	10.5	D.O.L	444748	444706	-	-	-	444175
BIFA50	2880	38°-40°	7.5	106	14.1	D.O.L	444748	444707	-	-	-	444176
BIFA56	2880	10°-14°	4	59.1	7.88	D.O.L	444747	444705	-	-	-	444175
BIFA56	2880	16°-18°	5.5	78.8	10.5	D.O.L	444748	444706	-	-	-	444175
BIFA56	2880	20°-24°	7.5	106	14.1	D.O.L	444748	444707	-	-	-	444176
BIFA63	2940	10°-12°	5.5	78.8	10.5	D.O.L	444748	444706	-	-	-	444175
BIFA63	2940	14°-16°	7.5	106	14.1	D.O.L	444748	444707	-	-	-	444176

## 1 Phase 4 Pole

Stock Ref	rpm	Pitch Angle	Motor kW	S.C. Amps	FLC Amps	Starting Method	Starter Ref	Overload Ref	Transform Controller	eDemand Controller		
										Voltage Control	1/3 Phase Inverter	3 Phase Inverter
BIFA25	1440	25°-50°	0.25	5	2	D.O.L	444744	444701	10314103	444164	-	-
BIFA31	1400	10°-40°	0.25	5	2	D.O.L	444744	444701	10314103	444164	-	-
BIFA40	1400	10°-40°	0.55	11	3.9	D.O.L	444744	444703	10314105	444164	-	-
BIFA45	1400	10°-40°	0.55	11	3.9	D.O.L	444744	444703	10314105	444164	-	-
BIFA50	1400	10°-34°	0.55	11	3.9	D.O.L	444744	444703	10314105	444164	-	-
BIFA50	1400	36°-40°	0.75	15	5.3	D.O.L	444744	444704	10314107	444165	-	-
ICA125	1475	32°-34°	45	193	80.5	Star Delta	-	-	-	-	-	-

## Electrical Details

### 3 Phase 4 Pole

Stock Ref	rpm	Pitch Angle	Motor kW	S.C. Amps	F.L.C Amps	Starting Method	Starter Ref	Overload Ref	Transform Controller	eDemand Controller	
										Voltage Control	3 Phase Inverter
BIFA25	1440	25°50°	0.25	5.04	0.84	D.O.L	444747	444699	10314301	444166	444172
BIFA31	1400	10°40°	0.25	5.04	0.84	D.O.L	444747	444699	10314301	444166	444172
BIFA40	1400	10°40°	0.55	9.48	1.58	D.O.L	444747	444701	10314304	444166	444172
BIFA45	1400	10°-40°	0.55	9.48	1.58	D.O.L	444747	444701	10314304	444166	444172
BIFA50	1400	10°34°	0.55	9.48	1.58	D.O.L	444747	444701	10314304	444166	444172
BIFA50	1400	36°40°	0.75	11.58	1.93	D.O.L	444747	444701	10314304	444166	444172
BIFA56	1400	10°16°	0.55	9.48	1.58	D.O.L	444747	444701	10314304	444166	444172
BIFA56	1400	18°22°	0.75	11.58	1.93	D.O.L	444747	444701	10314304	444166	444172
BIFA56	1400	24°30°	1.1	15.84	2.64	D.O.L	444747	444702	10314304	444166	444173
BIFA56	1400	32°36°	1.5	20.7	3.45	D.O.L	444747	444702	10314304	444166	444173
BIFA56	1400	38°40°	2.2	33.9	4.84	D.O.L	444747	444703	10314307	444167	444173
BIFA63	1400	10°	0.55	9.48	1.58	D.O.L	444747	444701	10314304	444166	444172
BIFA63	1400	12°-14°	0.75	11.58	1.93	D.O.L	444747	444701	10314304	444166	444172
BIFA63	1400	16°20°	1.1	15.84	2.64	D.O.L	444747	444702	10314304	444166	444173
BIFA63	1400	22°26°	1.5	20.7	3.45	D.O.L	444747	444702	10314304	444166	444173
BIFA63	1400	28°34°	2.2	33.9	4.84	D.O.L	444747	444703	10314307	444167	444174
BIFA63	1400	36°40°	3	45.3	6.47	D.O.L	444747	444704	10314311	444167	444174
BIFA71	1420	10°	0.75	11.58	1.93	D.O.L	444747	444701	10314304	444166	444172
BIFA71	1420	12°-14°	1.1	15.84	2.64	D.O.L	444747	444702	10314304	444166	444173
BIFA71	1420	16°-18°	1.5	20.7	3.45	D.O.L	444747	444702	10314304	444166	444173
BIFA71	1420	20°-24°	2.2	33.9	4.84	D.O.L	444747	444703	10314307	444167	444174
BIFA71	1420	26°30°	3	45.3	6.47	D.O.L	444747	444704	10314311	444167	444174
BIFA71	1420	32°36°	4	57.8	8.26	D.O.L	444747	444705	10314311	444167	444175
BIFA71	1420	38°40°	5.5	77	11	D.O.L	444748	444706	-	-	444175
BIFA80	1420	10°-12°	2.2	33.9	4.84	D.O.L	444747	444703	10314307	444167	444174
BIFA80	1440	14°20°	3	45.3	6.47	D.O.L	444747	444704	10314311	444167	444174
BIFA80	1440	22°-24°	4	57.8	8.26	D.O.L	444747	444705	10314311	444167	444175
BIFA80	1440	26°28°	5.5	77	11	D.O.L	444748	444706	-	-	444175
BIFA80	1440	30°34°	7.5	102.2	14.6	D.O.L	444748	444707	-	-	444176
BIFA80	1440	36°40°	11	52.3	20.9	Star Delta	444843	444707	-	-	-
BIFA90	1440	10°	3	45.3	6.47	D.O.L	444747	444704	10314311	444167	444174
BIFA90	1440	12°-16°	4	57.8	8.26	D.O.L	444747	444705	10314311	444167	444175
BIFA90	1440	18°20°	5.5	77	11	D.O.L	444748	444706	-	-	444175
BIFA90	1440	22°26°	7.5	102.2	14.6	D.O.L	444748	444707	-	-	444176
BIFA90	1440	28°32°	11	52.3	20.9	Star Delta	444843	444707	-	-	-
BIFA90	1440	34°40°	15	75.3	30.1	Star Delta	-	-	-	-	-
BIFA100	1440	10°-12°	4	57.8	8.26	D.O.L	444747	444705	10314311	444167	444175
BIFA100	1440	14°-16°	5.5	77	11	D.O.L	444748	444706	-	-	444175
BIFA100	1440	18°22°	7.5	102.2	14.6	D.O.L	444748	444707	-	-	444176
BIFA100	1440	24°26°	11	52.3	20.9	Star Delta	444843	444707	-	-	-
BIFA100	1440	28°32°	15	75.3	30.1	Star Delta	-	-	-	-	-
BIFA100	1440	34°38°	18.5	86	34.3	Star Delta	-	-	-	-	-
BIFA100	1440	40°	22	102	40.6	Star Delta	-	-	-	-	-

## Speed Controllers

Used in conjunction with speed controllable fans Vent-Axia offers a choice of speed controllers, the traditional Five-Step Auto Transformer or the Inverter Speed Controller.

The Five-Step-Auto Transformer provides five stepped speed settings without the electronic motor harmonic noise associated with all electronic or solid state type Speed Controllers.

For eDemand Speed Controllers & Inverters see Accessories & Controls Section.

## Accessory Dimensions (mm)

### Coupling Flange

Rolled from mild steel. Dimensionally matched to fan flange and fixing holes.

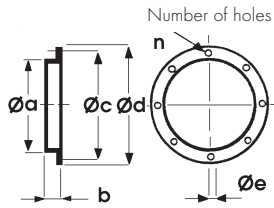

Stock Ref	a Ø	b	c Ø	d Ø	e Ø	n
10506250	327	55	292	254	10	4
10506315	385	30	355	315	10	8
10506400	480	45	450	400	12	8
10506450	530	60	500	450	12	8
10506500	590	0	560	500	12	12
10506560	650	75	620	560	12	12
10506630	720	75	690	630	12	12
10506710A	794	40	770	710	12	13
10506800A	884	40	860	800	12	13
10506900A	1100	50	970	900	14	15

### \*Anti-Vibration Mounts

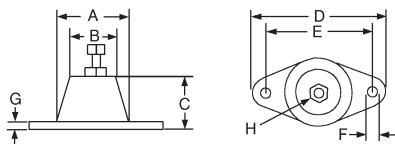

Stock Ref	Max. Load								kg
	A	B	C	D	E	F	G	H	
68MP033G	37	26	27	67	54	7	3	M8	23
68MP055B	37	26	27	67	54	7	3	M8	36
68MP133G	57	46	35	95	76	10.5	4	M12	91
68MP165R	57	46	35	95	76	10.5	4	M12	245

\*Supplied as a set of 4

### Inlet Wire Guard

'K' factor loss 0.25

Available for direct fixing to either side of the fan using flange sizing holes. Constructed to meet BS 848 Part 5.

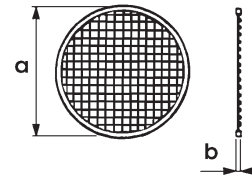

Stock Ref	a	b
10505250	245	3
10505315	380	3
10505400	475	3
10505450	525	3
10505500	595	3
10505560	655	3
10505630	725	3
10505710A	784	10
10505800A	870	10
10505900A	970	10
105051000A	1090	10

For more information on the 'K' factor, refer to General Information Section

### \*Mounting Feet

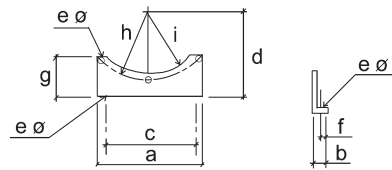

Stock Ref	a	b	c	d	e	f	g	h	i
10503250	232	24	180	240	10	14	115	146	130
10503315	275	24	224	240	10	14	115	177.5	167
10503400	348	24	280	300	12	14	135	225	213
10503450	384	24	315	360	12	14	155	250	238
10503500	425	24	315	360	12	14	135	280	268
10503560	475	24	355	355	12	14	155	310	298
10503630	520	24	400	400	12	14	175	345	333
10503710A	710	40	610	435	13	18	240	385	365
10503800A	800	40	700	480	13	18	262	430	410
10503900A	900	40	800	535	13	18	288	485	460
105031000A	1000	40	900	580	15	18	314	535	510

\*Supplied as a pair

## Accessories

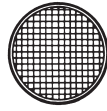
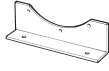

Model Ref	Mounting Feet Stock Ref	Inlet Wire Guard Stock Ref	Coupling Flange Stock Ref	Ancillary Pack* Stock Ref	Attenuator Stock Ref	Attenuator inc. Pod Stock Ref	Anti-Vibration Mount** Stock Ref
BIFA25	10503250	10505250	10506250	10513250HT	10514250	-	68MP033G
BIFA31	10503315	10505315	10506315	10513315HT	10514315	10500315	68MP033G
BIFA40	10503400	10505400	10506400	10513400HT	10514400	10500400	68MP033G
BIFA45	10503450	10505450	10506450	10513450HT	10514450	10500450	68MP033G
BIFA50	10503500	10505500	10506500	10513500HT	10514500	10500500	68MP033G
BIFA56	10503560	10505560	10506560	10513560HT	10514560	10500560	68MP033G
BIFA63	10503630	10505630	10506630	10513630HT	10514630	10500630	68MP033G
BIFA71	10503710A	10505710	10506710A	10513710HT	10514710A	10500710	68MP055B
BIFA80	10503800A	10505800	10506800A	10513800HT	10514800A	10500800	68MP055B
BIFA90	10503900A	10505900	10506900A	10513900HT	10514900A	10500900	68MP133G
BIFA100	105031000A	105051000	105061000A	105131000HT	105141000A	105001000	68MP133G

\*Axial Ancillary Pack consists of 2 Matching flanges, 2 Flexible Connectors, 2 Mounting Feet, 4 Anti Vibration Mounts and 4 Worm Drive Clips

\*\*Supplied as a set of 4

## Typical Installation

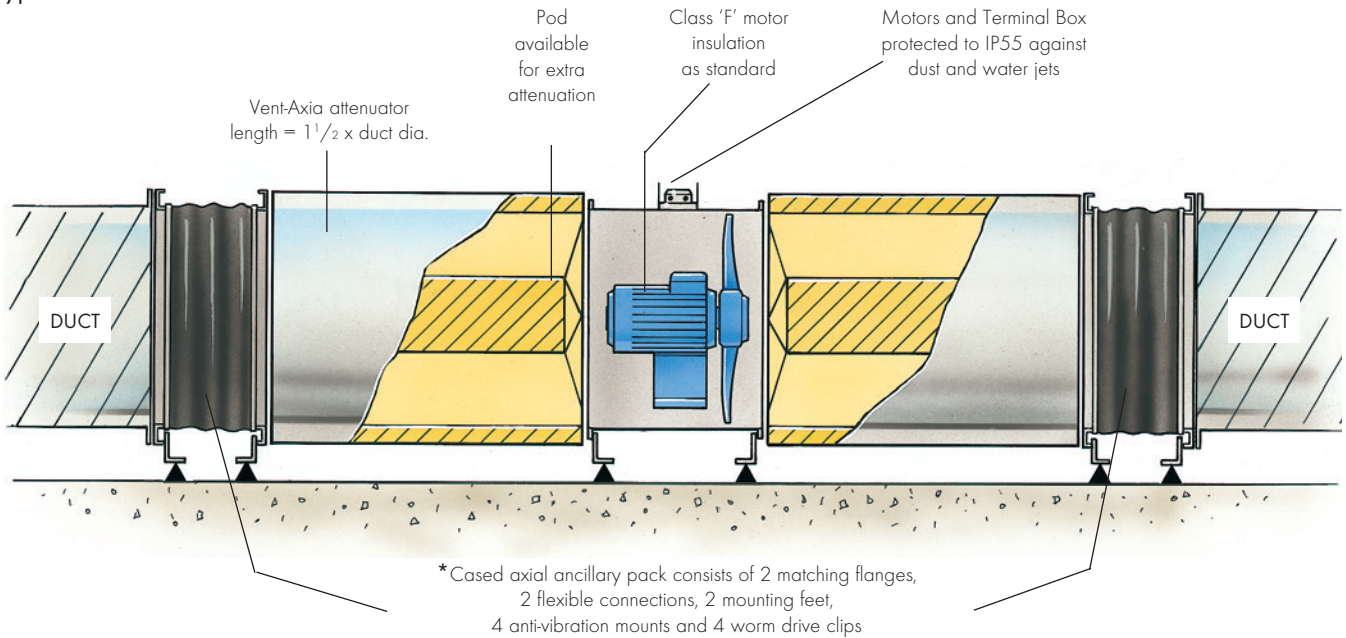

## Fan Attenuator Details

An attenuator without Pod offers negligible resistance to air flow, and therefore the pressure loss can be considered to be the same as that for the equivalent length of ducting.

### Resistance Graph for Axial Attenuator with Pod

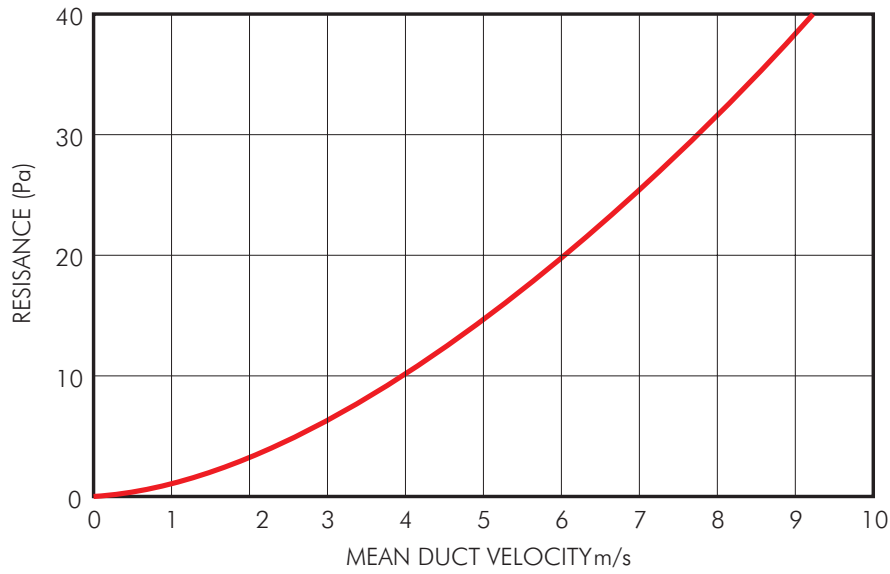

### Attenuator Insertion Loss Data

Dia	Stock Ref	63	125	250	500	1k	2k	4k	8k	kg approx
250	10514250	2	3	6	11	16	11	10	6	20
315	10514315	2	3	6	11	16	11	10	6	22
355	10514355	2	3	6	12	16	11	10	6	30
400	10514400	2	3	6	13	16	12	10	6	41
450	10514450	2	4	6	14	17	12	10	6	50
500	10514500	3	4	7	14	17	14	11	7	59
560	10514560	2	4	8	15	18	14	11	7	70
630	10514630	3	4	8	16	18	14	11	7	82
710	10514710	1	2	6	9	12	10	6	2	90
800	10514800	1	2	6	9	12	10	6	2	100
900	10514900	1	2	6	9	12	10	6	2	145
1000	10514000	1	2	6	9	12	10	6	2	184

Melinex lined attenuators are available on request

### Case Axial Attenuator Fitted with Pod Insertion Losses

Dia	Stock Ref	63	125	250	500	1k	2k	4k	8k	kg approx
315	10500315	6	7	12	18	27	25	22	19	32
355	10500355	3	8	12	18	28	26	22	19	44
400	10500400	3	8	12	18	28	26	23	19	60
450	10500450	4	8	14	20	28	26	23	19	73
500	10500500	4	8	14	20	29	26	23	19	87
560	10500560	4	9	14	20	29	26	23	19	102
630	10500630	4	9	14	20	29	26	23	19	120
710	10500710	6	10	20	30	35	28	25	22	134
800	10500800	6	10	20	30	35	28	25	22	149
900	10500900	6	10	20	30	35	28	25	22	211
1000	105001000	6	10	20	30	35	28	25	22	267



Attenuator Dimensions (mm)

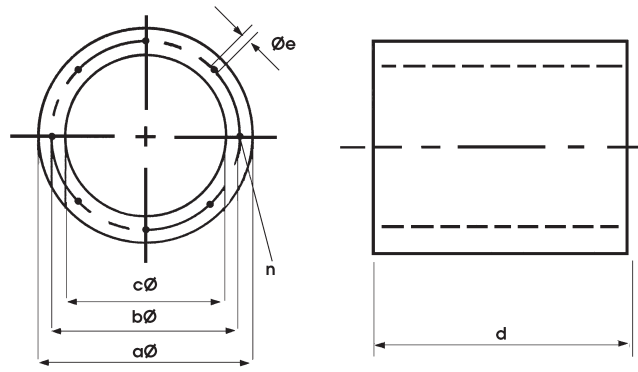

Model	Stock		a Ø	b Ø	c Ø	d	e Ø	n
	Ref							
BIFA25	10514250		350	292	254	375	M8	4
BIFA31	10514315		415	355	315	475	M8	8
BIFA35	10514355		455	395	355	540	M8	8
BIFA40	10514400		500	450	400	600	M10	8
BIFA45	10514450		550	500	450	675	M10	8
BIFA50	10514500		600	560	500	750	M10	12
BIFA56	10514560		660	620	560	810	M10	12
BIFA63	10514630		730	690	630	940	M10	12
BIFA71	10514710		814	700	710	1070	M10	16
BIFA80	10514800		900	860	796	1200	M10	16
BIFA90	10514900		999	970	893	1350	M10	16
BIFA100	105141000		1108	1070	1070	1500	M10	16
BIFA125	105141250		1350	1320	1250	1875	M10	20

# In-line Fans



The Vent-Axia in-line fan range features both box and tube fans designed to provide controllable environmental management solutions for commercial and industrial applications.

With sizes ranging from 100mm to 710mm diameter and air volumes up to 5.63m<sup>3</sup>/s optimum performance at minimum running costs is assured.

Where noise is an issue, our ACQ range has been updated to include backward curved fans for energy efficiency and a highly sound absorbent acoustic foam to minimise breakout and induct sound levels, yet maintain a low profile for ceiling void applications.

Designed specifically to fully comply with the new Building Regulations for Commercial Kitchens and fully tested within the aggressive conditions observed in commercial kitchen applications the EKF range with its EC motor out of the airstream achieves low specific fan powers (<1.0w/l/s), has a multi spigot arrangement and is suitable for 120°C in duct temperature.

**Vent-Axia**





EuroSeries (SDX EC) In-Line Centrifugal Duct Fans

K3-K6

---



Lo-Carbon Kitchen Box Fans (EKF)

K7-K14

---



Acoustic In-Line Fans (ACQ)

K15-K20

---



Eco Mixed Flow Fans (eMF)

K21-K26

---



Powerflow In-Line Duct Fans (ACP)

K27-K30

---



EuroSeries (SDX) In-Line Centrifugal Duct Fans

K31-K34

---



NEW Slimpak EC Box Fan (SLP EC)

K35-K40

---



Square Mixed Flow Fans (MFQ)

K41-K46

---



# EuroSeries (SDX EC)

- Available in sizes 125 to 315
- EC Motor, backward curved impeller
- Protected to IPX2
- Mounting for internal use
- Integral speed setting potentiometer
- 0-10v potentiometer speed controllable
- Operating temperatures from -25°C up to +60°C
- Quality Assurance to BS EN ISO 9001:2015
- 2 Year Warranty



The SDX EC Euroflow in-line centrifugal duct fans are designed around an efficient backward curved centrifugal impeller and EC motor to ensure a compact and efficient unit, providing high performance and controllability as standard.

The in-line fan casing is constructed from epoxy coated pressed steel and incorporates an aerodynamically designed airflow guide vane, ensuring maximum performance from the unit while maintaining minimum noise levels. All models are supplied with a simple mounting foot for ease of installation.

The SDX EC range is available in five model sizes: 125, 150, 200, 250 & 315mm diameter as standard performance.

The range provides a performance up to 0.36m<sup>3</sup>/s with a maximum pressure development of 600 Pa.

The SDX EC range is suitable for the extraction of clean air only. It is not suitable for extracting or transporting grinding dust, soot, explosive or other aggressive gases etc.

---

## Impellers

All SDX EC units feature an energy efficient, Class 1, EC/DC external rotor motor and backward curved impeller assembly specifically chosen for performance and non-overloading characteristics. The assembly is dynamically balanced to DIN ISO 1940 Grade 6.3, IP44 according to BS EN 60529.

Ball bearings are greased for life. Insulation is Class 'B' (from -25°C to +60°C). All models incorporate internal electronic overload protection and soft start function.

---

## Control

Every SDX EC unit is fitted with a integral commissioning potentiometer giving the ability to set the exact duty required at commissioning. Alternatively, the integral potentiometer can be bypassed to allow remote speed control via an external 0-10V potentiometer.

---

## Terminal Box

An IP55 terminal box fitted to the casing with multiple cable entry positions.

---

## Performance

The fan characteristic curves were determined in accordance with EN ISO 5801. The sound levels were determined in accordance with DIN 45635 resp. ISO 3744 at a distance of 1m from the fan.

---

## Quality Assurance

Design and manufacture is in accordance with the standard for quality management systems BS EN ISO 9001:2015.

---

## Accessories

A full range of accessories are available with the Euroflow in-line centrifugal duct fans such as:

- 0-10V potentiometer
  - Pre & Secondary Filter Cassettes
  - Electric Heater Batteries
  - In-Line Attenuators
  - Backdraught Shutters
  - Fast Clamps
  - Flexible Ducting
  - Wall Terminals
  - Roof Terminals
-



## Dimensions (mm)

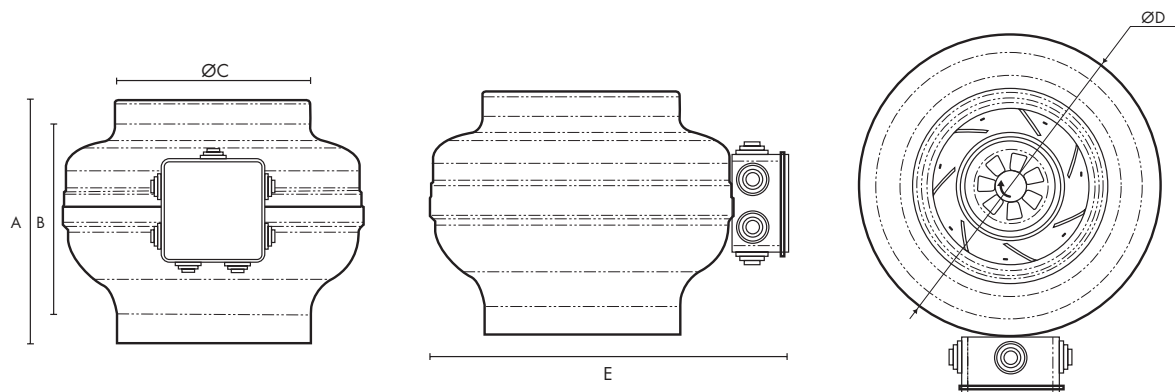

Unit Size	A	B	$\text{ØC}$	$\text{ØD}$	E	kg
SDX125EC	207	175	125	245	290	2.1
SDX150EC	222	172	150	344	386	3.1
SDX200EC	240	190	200	345	390	3.7
SDX250EC	245	185	250	345	390	3.6
SDX315EC	250	180	315	400	445	4.6

Performance Curves

SDX EC 125-315

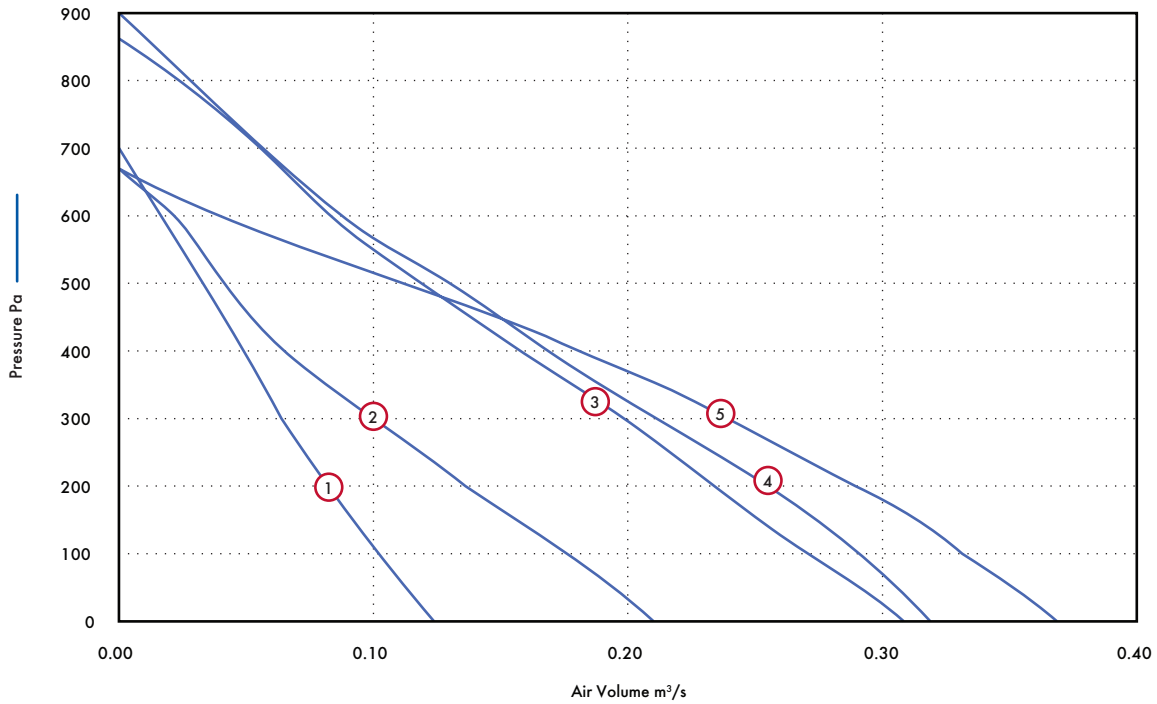

Performance Guide

Dia.	Motor Phase	Stock Ref	r.p.m	IP Rating	Curve Ref.	m <sup>3</sup> /s @ Pa								Motor kW	F.L.C Amps	dBA @ 3m		
						0	50	100	150	200	300	400	500				600	700
125	1	SDX125EC 3200	IPX2	1	m <sup>3</sup> /s	0.12	0.11	0.10	0.09	0.08	0.06	0.05	0.03	0.02	0.08	0.75	35	
					kW	0.08	0.08	0.08	0.08	0.08	0.08	0.08	0.07	0.07				
					W/l/s	0.67	0.73	0.81	0.89	1.01	1.27	1.59	2.07	3.96				
150	1	SDX150EC 2550	IPX2	2	m <sup>3</sup> /s	0.21	0.19	0.18	0.16	0.14	0.10	0.06	0.04	0.02	0.09	0.7	41	
					kW	0.09	0.09	0.09	0.09	0.09	0.09	0.09	0.09	0.09				
					W/l/s	0.43	0.47	0.51	0.57	0.67	0.91	1.41	2.17	4.55				
200	1	SDX200EC 3230	IPX2	3	m <sup>3</sup> /s	0.31	0.29	0.27	0.25	0.23	0.20	0.16	0.12	0.08	0.06	0.17	1.4	33
					kW	0.17	0.17	0.16	0.16	0.17	0.17	0.16	0.17	0.16	0.16			
					W/l/s	0.54	0.59	0.60	0.64	0.71	0.85	1.04	1.37	1.92	2.88			
250	1	SDX250EC 3230	IPX2	4	m <sup>3</sup> /s	0.32	0.31	0.29	0.27	0.26	0.22	0.17	0.13	0.09	0.06	0.17	1.4	33
					kW	0.17	0.17	0.17	0.17	0.17	0.17	0.17	0.17	0.17	0.17			
					W/l/s	0.52	0.54	0.57	0.61	0.65	0.78	0.99	1.30	1.89	0.28			
315	1	SDX315EC 2510	IPX2	5	m <sup>3</sup> /s	0.37	0.35	0.33	0.31	0.29	0.24	0.18	0.11	0.04	0.17	1.4	41	
					kW	0.14	0.14	0.15	0.16	0.16	0.17	0.16	0.15	0.12				
					W/l/s	0.37	0.40	0.45	0.52	0.56	0.69	0.90	1.33	3.14				

Sound Power Level Spectra dB (ref 10<sup>-12</sup> Watts)

Dia.	Motor Phase	Stock Ref	Spectrum	125	250	500	1k	2k	4k	8k	dBA @ 3m
125	1	SDX125EC	Inlet	53	58	68	64	66	61	54	50
			Outlet	48	53	63	59	61	56	49	45
			Breakout	38	43	51	48	51	46	39	35
150	1	SDX150EC	Inlet	56	60	71	66	69	63	57	53
			Outlet	51	55	66	61	64	58	52	35
			Breakout	44	48	59	54	57	51	45	41
200	1	SDX200EC	Inlet	20	62	69	72	71	68	64	56
			Outlet	48	57	64	67	66	63	59	51
			Breakout	-2	39	46	49	48	45	41	33
250	1	SDX250EC	Inlet	20	62	69	72	71	68	64	56
			Outlet	48	57	64	67	66	63	59	51
			Breakout	-2	39	46	49	48	45	41	33
315	1	SDX315EC	Inlet	55	63	67	71	70	72	62	56
			Outlet	50	58	62	66	65	67	57	51
			Breakout	40	48	52	56	55	57	47	41

## Models & Accessories

Fan Stock Ref	0-10v external control Stock Ref
SDX125EC	426332
SDX150EC	426332
SDX200EC	426332
SDX250EC	426332
SDX315EC	426332

Dia	In-Line Attenuators			
	300mm Stock Ref	600mm Stock Ref	900mm Stock Ref	1200mm Stock Ref
125	83012030	83012060	83012090	-
150	83015030	83015060	83015090	-
200	-	83020060	83020090	83020120
250	-	83025060	83025090	83025120
315	-	83031060	83031090	83031120

Fan Stock Ref	Wall Terminal Stock Ref	Wall Terminal Stock Ref	Electric Heaters Stock Ref	Panel Filters Stock Ref
125	SA125/280	SA125/80	10531125T1	QPF125A
150	SA150/280	SA150/80	10531150T1	QPF150A
200	SA200/280	SA200/80	10531200T1	QPF200A
250	SA250/280	SA250/80	10531250T1	QPF250A
315	SA315/280	SA315/80	10531315T1	QPF315A

Fan Stock Ref	Bag Filters Stock Ref	Roof Terminal Stock Ref	Louvre Shutter Stock Ref
125	QPFB125A	WB160	LS250
150	QPFB150A	WB160	LS250
200	QPFB200A	WB200	LS250
250	QPFB250A	RCZ300	LS250
315	QPFB315A	RCZ300	LS315



# Lo-Carbon Kitchen Box Fan (EKF)

- Energy efficient EC motor
- 120°C airstream rated
- Sealed for life motor
- Flexible installation, straight through or turn through 90° as standard
- Internal or external mounting as standard
- 25mm Double skin casing
- Integral IP65 Isolator
- Simple potentiometer control
- Compliant part L 2013 SFP for requirements for kitchen ventilation systems



Vent-Axia's latest product offering in the Non Residential sector is a centrifugal box fan specifically designed for kitchen operation at elevated duct temperatures of up to 120°C. Working closely with our Engineering partner, the motor impeller arrangement has been specifically engineered to benefit from the efficiencies of an EC external rotor motor mounted out of the airstream to allow for operation at 120°C in duct temperatures.

## Construction

The casing is constructed from a framed 25mm double skin with acoustic insulation to minimise unit noise. With careful thought to maximising the installation possibilities from one unit Vent-Axia have managed to create a single unit that is suitable for both internal and external mounting as standard. In addition to this the duct configuration can be either straight blow through or turn through 90° and with the motor shaft either horizontal or vertical this enables the fan to be mounted in any orientation.

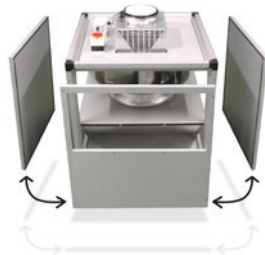

## Motor

The Kitchen Box Fan range is powered by highly efficient, electronically commutated (EC) motors with permanent magnets, exceeding the minimum efficiency requirements for IE3 motors. All units are fully speed controllable via the onboard electronics utilising a 0-10V input signal. Motors and the onboard electronics are protected to IP54 as standard mounted and are out of the airstream.

The combination of an EC high efficiency motor and a high efficiency backward curved impeller ensures ERP 2015 compliance.

## Impeller

A backward curved welded Aluminium impeller is mounted on an extended shaft from the EC external motor. Motor and impeller is balanced as a finished assembly to G2.5 to ensure vibration free operation. Impeller matched to inlet cone for optimum performance.

## Speed Control

By utilising EC motors the EKF range has been designed for simple Demand Ventilation control facilitated by use of a 0-10V potentiometer. This low voltage controller can then be mounted within the kitchen area thereby removing the risk of overheating or damaging the control circuits.

## Performance

The fan performance has been tested in accordance with ISO 5801 DIN 24163.

## Sound Levels

Fan sound levels were measured in a reverberant chamber in accordance with EN ISO 3745. Published dB(A) figures are free field at a distance of 3m with hemispherical propagation at a reference level of  $2 \times 10^{-5}$ . The sound power level spectra figures are dB with a reference level of  $10^{-12}$  Watts.

## Electrical

Depending on unit size the EKF range is suitable for either single phase 220-240V 50Hz or three phase 380-414V 50Hz. All mains wiring is direct to the built in IP65 isolator mounted on the motor support plate providing simple and safe connection and operation.

## Accessories

A full range of accessories are available for the EKF range including:

- Potentiometer speed controller (included as standard)
- Square to round duct connectors
- Flexible connectors
- Mounting support and A/V mount set
- Weather cowl
- Discharge louvre

## Online Documentation

For digital catalogue information, fitting & wiring instructions and online fan selection programme visit [www.vent-axia.com/ekf](http://www.vent-axia.com/ekf)

## Fan Dimensions (mm)

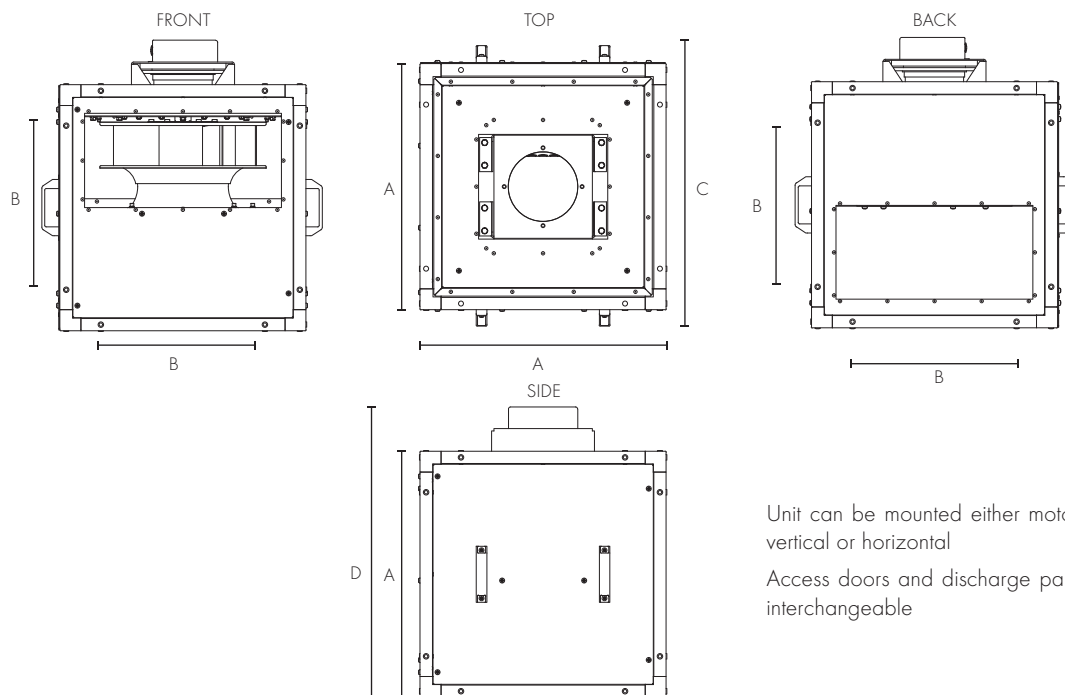

Unit can be mounted either motor shaft vertical or horizontal  
Access doors and discharge panel are interchangeable

Model	A	B	C	D	Weight (kg)
EKF355E1	600	400	684	708	63
EKF400E1	700	500	784	826	81
EKF450E1	700	500	784	826	83.5
EKF450E3	700	500	784	826	83.5
EKF500E3	850	650	929	1017	130
EKF560E3	850	650	929	1017	132

# Performance Guide

EKF355E1

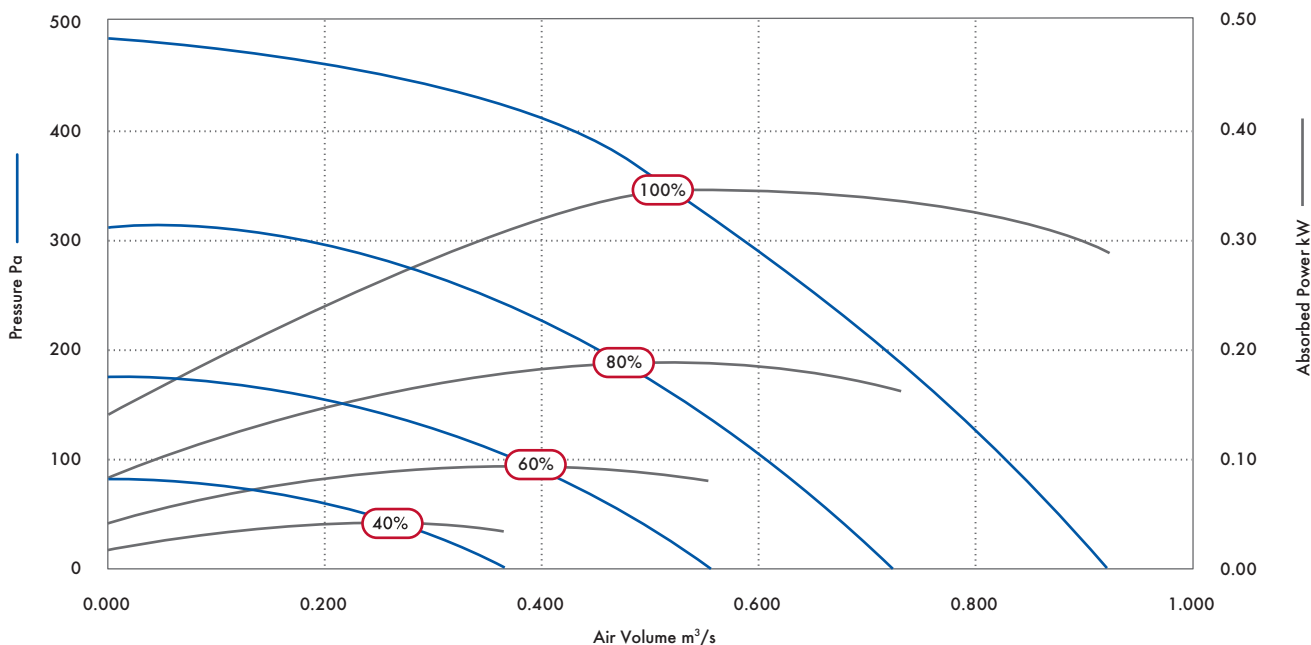

Speed	Air Volume m <sup>3</sup> /s											Fans F.L.C.	Supply Voltage	
	0	50	100	150	200	250	300	350	400	450	475			
100%	m <sup>3</sup> /s	0.920	0.866	0.815	0.767	0.700	0.630	0.600	0.510	0.435	0.275		1.7	220V/ 1/ 50Hz
	kW	0.29	0.31	0.32	0.32	0.33	0.34	0.34	0.34	0.33	0.27			
	SFP	0.32	0.35	0.39	0.42	0.48	0.54	0.60	0.66	0.76	0.97			
80%	m <sup>3</sup> /s	0.737	0.665	0.605	0.538	0.455	0.360	0.140					1.0	
	kW	0.16	0.17	0.18	0.19	0.18	0.18	0.13						
	SFP	0.22	0.26	0.30	0.35	0.41	0.50	0.90						
60%	m <sup>3</sup> /s	0.554	0.475	0.375	0.230								0.7	
	kW	0.08	0.09	0.09	0.08									
	SFP	0.14	0.18	0.24	0.36									
40%	m <sup>3</sup> /s	0.368	0.230										0.5	
	kW	0.04	0.04											
	SFP	0.095	0.172											

# Sound Data

Speed	Test Mode	Octave Band Frequency SWL								SPL dB(A) @ 3m
		63	125	250	500	1K	2K	4K	8K	
100%	Inlet	50	66	66	63	60	61	58	52	49
	Outlet	48	66	67	67	69	66	62	55	
	Breakout	62	71	72	64	66	58	53	47	
80%	Inlet	46	62	58	57	55	55	51	46	47
	Outlet	42	61	59	61	63	60	55	48	
	Breakout	61	77	72	61	59	53	47	41	
60%	Inlet	43	51	50	51	48	48	43	37	38
	Outlet	36	39	48	52	56	55	52	46	
	Breakout	58	70	62	54	48	44	37	32	
40%	Inlet	40	46	45	45	40	39	33	30	29
	Outlet	34	36	44	43	40	39	35	30	
	Breakout	57	59	51	46	39	33	27	31	

# Performance Guide

EKF400E1

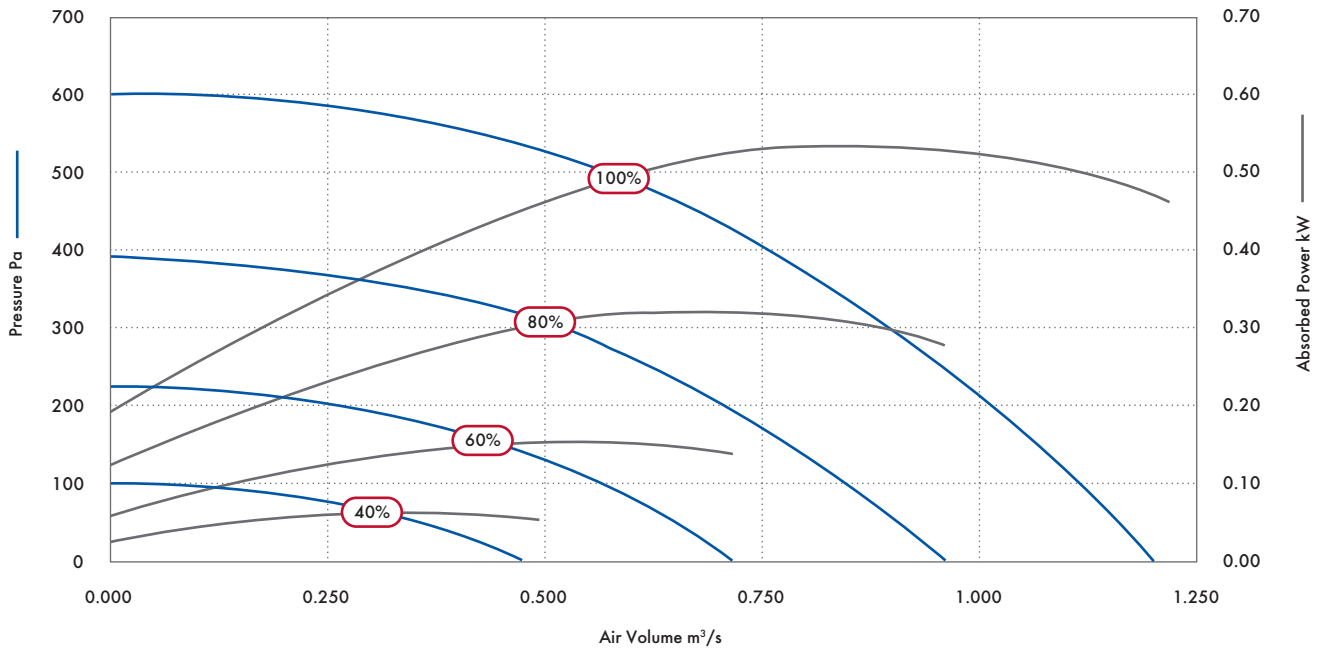

Speed	Air Volume m³/s													Fans F.L.C.	Supply Voltage
	0	50	100	150	200	250	300	350	400	450	500	600			
100%	m³/s	1.206	1.160	1.115	1.065	1.020	0.965	0.907	0.845	0.765	0.685	0.586	0.175	3.0	220V/ 1/ 50Hz
	kW	0.53	0.55	0.56	0.58	0.59	0.60	0.61	0.61	0.60	0.59	0.56	0.33		
	SFP	0.44	0.47	0.50	0.55	0.58	0.62	0.67	0.72	0.79	0.86	0.96	1.90		
80%	m³/s	0.961	0.907	0.845	0.780	0.705	0.622	0.520	0.350					2.2	
	kW	0.28	0.30	0.31	0.32	0.32	0.32	0.31	0.26						
	SFP	0.29	0.33	0.36	0.40	0.45	0.51	0.59	0.75						
60%	m³/s	0.721	0.640	0.552	0.438	0.235							1.6		
	kW	0.13	0.14	0.15	0.14	0.12									
	SFP	0.18	0.22	0.27	0.33	0.51									
40%	m³/s	0.480	0.351	0.012										0.8	
	kW	0.06	0.05	0.03											
	SFP	0.11	0.16	2.50											

## Sound Data

Speed	Test Mode	Octave Band Frequency SWL								SPL dB(A) @ 3m
		63	125	250	500	1K	2K	4K	8K	
100%	Inlet	61	70	69	66	65	64	60	54	56
	Outlet	58	70	73	72	73	69	64	57	
	Breakout	69	90	94	70	67	63	57	53	
80%	Inlet	54	61	60	59	59	58	54	47	49
	Outlet	50	61	65	66	67	63	58	51	
	Breakout	65	81	73	65	61	56	50	44	
60%	Inlet	49	52	52	51	51	50	45	38	42
	Outlet	45	52	57	59	59	54	49	45	
	Breakout	62	75	64	57	52	46	40	34	
40%	Inlet	44	47	47	44	44	43	40	33	32
	Outlet	40	46	47	45	45	43	42	35	
	Breakout	60	62	54	49	44	35	28	31	

# Performance Guide

EKF450E1/EKF450E3

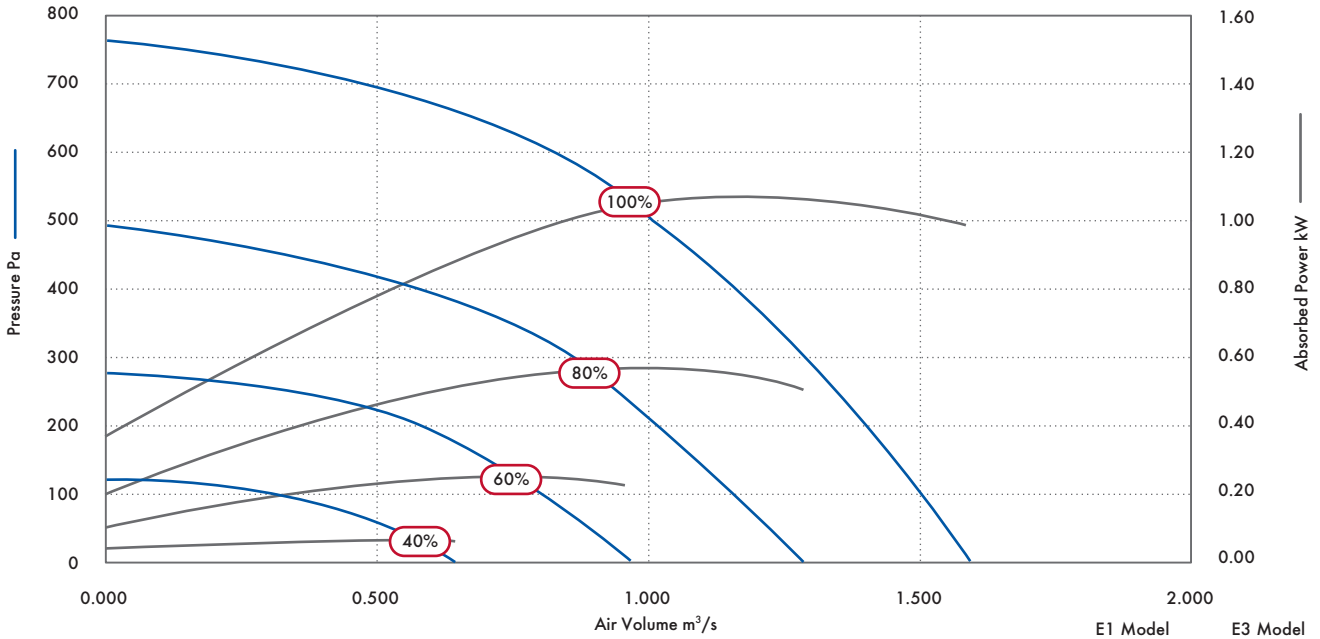

Speed	Airflow, m³/s @ Pa														E1 Model		E3 Model					
	0	50	100	150	200	250	300	350	400	450	500	550	600	700	Fans F.L.C.	Supply Voltage	Fans F.L.C.	Supply Voltage				
100%	m³/s	1.602	1.555	1.505	1.458	1.408	1.356	1.290	1.220	1.160	1.092	1.012	0.925	0.840	0.462	5.2	220V/ 1/ 50Hz	1.8	400V/ 3/ 50Hz			
	kW	0.99	1.01	1.03	1.04	1.05	1.07	1.07	1.07	1.06	1.06	1.05	1.03	1.00	0.76							
	SFP	0.62	0.65	0.68	0.71	0.75	0.79	0.83	0.87	0.92	0.97	1.04	1.12	1.19	1.64							
80%	m³/s	1.285	1.228	1.166	1.095	1.015	0.938	0.855	0.762	0.582						3.8		1.0				
	kW	0.51	0.53	0.54	0.55	0.55	0.55	0.55	0.54	0.49												
	SFP	0.40	0.43	0.46	0.50	0.55	0.59	0.64	0.71	0.84												
60%	m³/s	0.962	0.881	0.786	0.685	0.556	0.350												2.7		0.8	
	kW	0.23	0.24	0.25	0.24	0.24	0.20															
	SFP	0.24	0.27	0.31	0.35	0.43	0.58															
40%	m³/s	0.640	0.511	0.290												1.9		0.5				
	kW	0.08	0.09	0.08																		
	SFP	0.13	0.17	0.26																		

## Sound Data

Speed	Test Mode	Octave Band Frequency SWL								SPL dB(A) @ 3m
		63	125	250	500	1K	2K	4K	8K	
100%	Inlet	55	70	67	68	70	70	66	60	59
	Outlet	54	70	77	77	78	75	70	63	
	Breakout	70	81	86	74	68	63	57	52	
80%	Inlet	51	70	59	63	65	64	60	54	52
	Outlet	46	48	68	69	72	72	69	64	
	Breakout	71	84	76	69	63	57	50	44	
60%	Inlet	50	57	53	55	58	55	50	44	45
	Outlet	36	45	56	62	64	65	60	54	
	Breakout	66	78	66	62	54	49	40	40	
40%	Inlet	45	50	46	48	51	50	43	37	34
	Outlet	31	42	48	53	55	56	52	38	
	Breakout	65	66	55	52	46	37	29	32	

# Performance Guide

EKF500E3

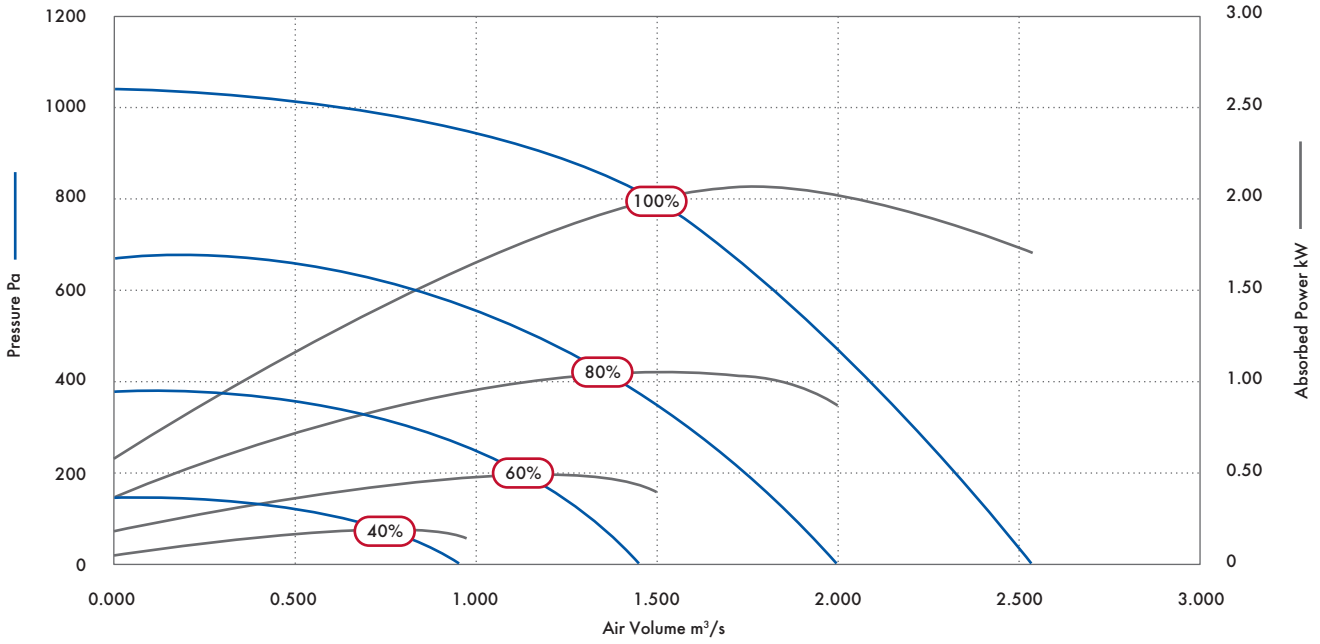

Speed	Airflow, m³/s @ Pa												Fans F.L.C.	Supply Voltage					
	0	100	200	300	400	500	600	700	800	900	1000	1250			1539				
100%	m³/s	2.543	2.450	2.320	2.190	2.075	1.935	1.835	1.700	1.458	1.250	0.539			3.6	400V/ 3/ 50Hz			
	kW	1.71	1.76	1.82	1.89	1.96	2.03	2.07	2.10	2.00	1.85	1.25							
	SFP	0.67	0.72	0.78	0.86	0.95	1.05	1.13	1.23	1.37	1.53	2.29							
80%	m³/s	2.002	1.900	1.765	1.570	1.372	1.178	0.754							2.6		400V/ 3/ 50Hz		
	kW	0.88	1.01	1.04	1.05	1.04	1.02	0.87											
	SFP	0.44	0.53	0.59	0.67	0.76	0.87	1.16											
60%	m³/s	1.499	1.330	1.129	0.850										1.8			400V/ 3/ 50Hz	
	kW	0.40	0.47	0.49	0.46														
	SFP	0.26	0.35	0.43	0.54														
40%	m³/s	0.966	0.665												1.0				400V/ 3/ 50Hz
	kW	0.18	0.22																
	SFP	0.19	0.33																

## Sound Data

Speed	Test Mode	Octave Band Frequency SWL								SPL dB(A) @ 3m
		63	125	250	500	1K	2K	4K	8K	
100%	Inlet	62	73	70	71	77	73	74	69	60
	Outlet	60	76	82	80	83	81	79	75	
	Breakout	75	82	88	73	69	68	65	59	
80%	Inlet	60	66	62	66	67	67	61	56	52
	Outlet	56	67	72	74	75	71	66	60	
	Breakout	70	81	77	69	64	62	59	51	
60%	Inlet	51	61	56	58	61	60	55	50	45
	Outlet	50	62	65	66	68	64	60	55	
	Breakout	66	74	70	61	57	53	49	43	
40%	Inlet	46	56	51	53	50	55	50	43	35
	Outlet	43	55	56	57	59	55	51	48	
	Breakout	63	62	58	52	48	41	34	31	

# Performance Guide

EKF560E3

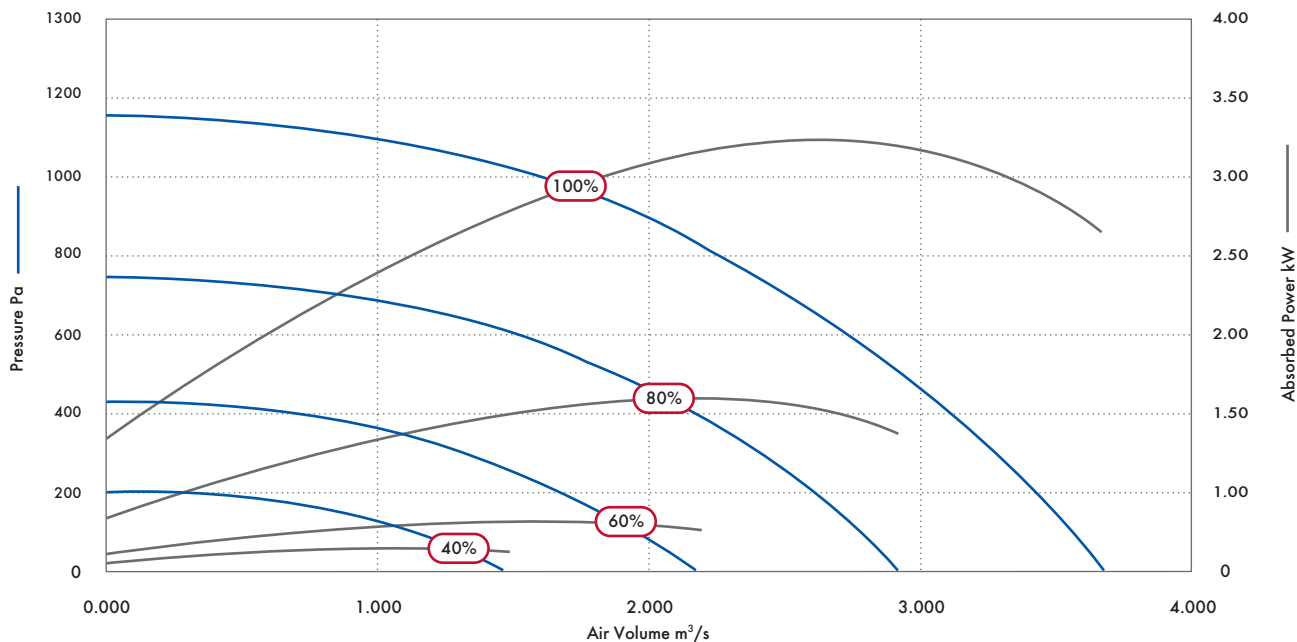

Speed	Air Volume m <sup>3</sup> /s													Fans F.L.C.	Supply Voltage	
	0	100	200	300	400	500	600	700	800	900	1000	1100				
100%	m <sup>3</sup> /s	3.693	3.570	3.440	3.310	3.135	2.940	2.725	2.507	2.278	2.004	1.650	0.930			
	kW	2.58	2.75	2.92	3.00	3.10	3.14	3.17	3.20	3.15	3.08	2.83	2.16	5.5	400V/ 3/ 50Hz	
	SFP	0.70	0.77	0.85	0.91	0.99	1.07	1.16	1.27	1.38	1.54	1.72	2.32			
80%	m <sup>3</sup> /s	2.926	2.780	2.585	2.405	2.155	1.860	1.500	0.900							
	kW	1.33	1.45	1.56	1.61	1.62	1.60	1.51	1.20					3.9		
	SFP	0.45	0.52	0.60	0.67	0.75	0.86	1.01	1.33							
60%	m <sup>3</sup> /s	2.192	1.987	1.672	1.293	0.600										
	kW	0.59	0.65	0.69	0.69	0.49								2.8		
	SFP	0.27	0.33	0.42	0.53	0.81										
40%	m <sup>3</sup> /s	1.481	1.081	0.019												
	kW	0.27	0.32	0.11										1.3		
	SFP	0.18	0.30	5.74												

## Sound Data

Speed	Test Mode	Octave Band Frequency SWL								SPL dB(A) @ 3m
		63	125	250	500	1K	2K	4K	8K	
100%	Inlet	64	78	81	74	77	76	72	67	65
	Outlet	62	76	83	83	83	81	76	70	
	Breakout	82	87	87	81	73	70	67	62	
80%	Inlet	65	78	75	72	75	74	70	64	60
	Outlet	63	77	79	81	81	79	74	67	
	Breakout	77	85	80	76	68	65	61	56	
60%	Inlet	60	67	63	60	64	60	56	50	52
	Outlet	56	65	67	70	70	66	60	54	
	Breakout	73	78	72	68	62	58	52	50	
40%	Inlet	53	60	56	53	57	53	49	43	44
	Outlet	48	55	57	60	60	56	51	46	
	Breakout	68	67	64	60	55	47	38	41	



## Accessories

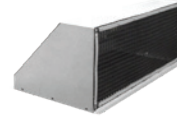
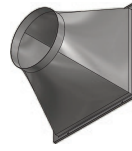

Unit Size	Mounting Bracket & A/V Mount Set	Flexible Connector	Square to Circular Duct Transformation Section	Discharge Cowl	Weather Roof
EKF355	EKFMF355	EKFFC355	EKFTP35-35	EKFDC355	EKFWR355
EKF400	EKFMF400	EKFFC400	EKFTP40-40	EKFDC400	EKFWR400
EKF450	EKFMF400	EKFFC400	EKFTP40-45	EKFDC400	EKFWR400
EKF500	EKFMF500	EKFFC500	EKFTP50-50	EKFDC500	EKFWR500
EKF560	EKFMF500	EKFFC500	EKFTP50-56	EKFDC500	EKFWR500

## Accessories Dimensions

### Mounting Bracket & A/V Mount Set

Stock Ref	A	B	C	DØ	E	F	G	HØ	I	J	K
EKFMF355	600	100	400	13	25	700	750	9	30	100	35
EKFMF400	700	100	500	13	25	800	850	9	30	100	35
EKFMF400	700	100	500	13	25	800	850	9	30	100	35
EKFMF500	850	100	650	13	25	950	1000	9	30	100	35
EKFMF500	850	100	650	13	25	950	1000	9	30	100	35

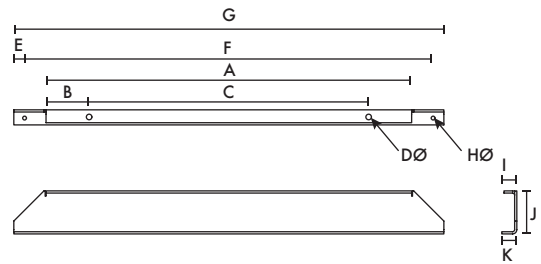

### Square to Circular Duct Transformation Section

Stock Ref	A	B	C	DØ	E	F	G	H
EKFTP35-35	600	100	400	348	50	400	540	570
EKFTP40-40	700	100	500	398	50	400	640	670
EKFTP40-45	700	100	500	448	50	400	640	670
EKFTP50-50	850	100	650	498	50	400	790	820
EKFTP50-56	850	100	650	558	50	400	790	820

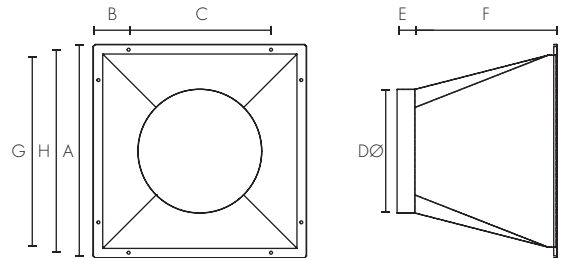

### Flexible Connector

Stock Ref	A	B	C	D	EØ	F	G
EKFFC355	600	100	400	34	8	570	150
EKFFC400	700	100	500	34	8	670	150
EKFFC500	850	100	650	34	8	820	150

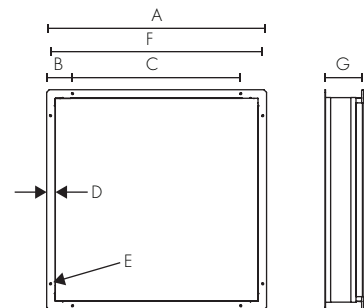

Note: weather roof and cowl dimensions on application

# Acoustic In-Line Fans (ACQ)

- Acoustically treated housing, Class 'O' rated, sandwich construction selected for maximum noise absorption
- Motors protected to IP44
- Motor insulation Class 'B'
- Maximum operating temperature 50°C
- Standard Thermal Overload Protection
- Aluzinc construction for internal or external mounting as standard
- All models speed controllable
- Manufacture controlled to BS EN ISO 9001
- Performance tested to ISO 5801



The ACQ fans feature an acoustic foam of dual density sandwich construction specially selected for maximum sound absorption and quiet operation. The housing is designed to be as compact as possible for concealed false ceiling applications.

Manufactured in Aluzinc sheet metal, with integral anchorage points to allow the fan to be suspended at any angle, via drop rods or anti vibration mounts, ensuring a quick and easy solution to installation of the in-line acoustic fans. The access panel is easily removed for inspection.

The full range of Acoustic fans manufactured from Aluzinc and as such are suitable for both internal and external mounting as standard.

Ten models are available in sizes 100, 125, 150, 160, 200, 250, 315, 400 and 500, providing air volumes from 0.075m<sup>3</sup>/s to 1.609m<sup>3</sup>/s (270m<sup>3</sup>/h to 5,792 m<sup>3</sup>/h) at free air. Designed for pressures up to 550 Pa.

---

## Motors

At the heart of the range is a proven external rotor motor and backward curved impeller selected for low noise and high efficiency impeller assembly specially selected for its performance. The assembly is dynamically balanced to ISO 1940. Motors are rated to IP44 according to BS EN 60529. Ball bearings are greased for life and allow the fan to run at any angle. Insulation is Class 'B' (from -15°C to +50°C).

All Acoustic fans are suitable for speed control with either an Electronic or Auto Transformer. An Auto Transformer is recommended to ensure minimum noise levels during speed control so eliminating any possibility of motor harmonic noise.

---

## Terminal Box

An IP54 Terminal Box is supplied with all models with 20mm cable gland entry.

---

## Sound and Performance

Tested to ISO5801. Published dB(A) figures are free field sound pressure levels at 3m with spherical propagation at a reference level of  $2 \times 10^{-5}$ Pa (20 micro-Pascal). The inlet, outlet and breakout sound power level spectra figures are dB with a reference of  $10^{-12}$  Watts (1 pico-watt).

---

## Electrical

The ACQ range is supplied with motors wound to suit a 230V/1ph/50Hz supply capacitor start and run.

---

## Quality Assurance

Design and manufacture is in accordance with BS EN ISO 9001:2015.

## Fan Dimensions (mm)

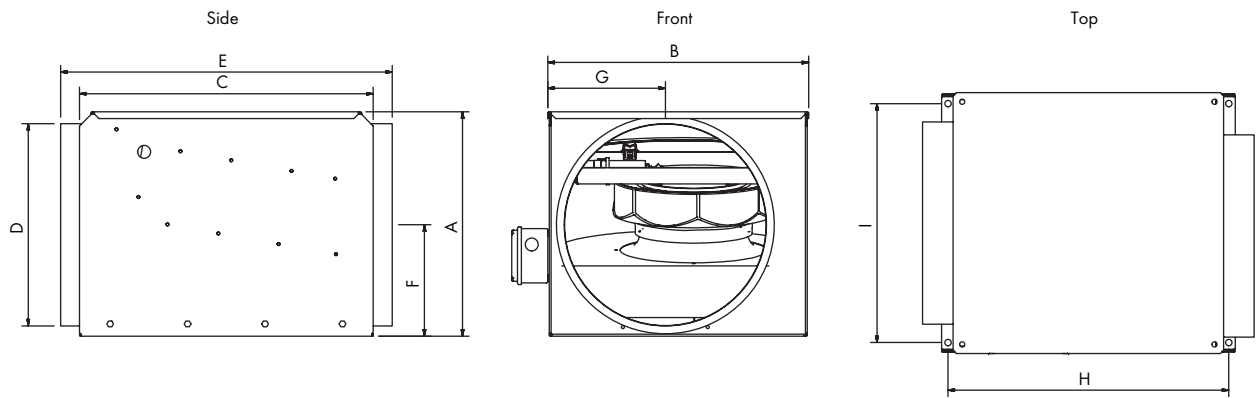

Stock Ref.	A	B	C	D	E	F	G	H	I	kg
ACQ10012D	190	310	400	100	460	94	111	380	275	11
ACQ12512D	190	310	400	125	460	94	111	380	275	11
ACQ15012D	190	310	400	150	460	94	111	380	275	11
ACQ16012D	190	310	400	160	460	94	111	380	275	11
ACQ20012D	285	364	455	200	515	141	127	435	330	17
ACQ25012D	285	364	455	250	515	141	127	435	330	17
ACQ315121D	348	404	455	315	515	173	182	435	370	21
ACQ31514HD	456	572	730	315	795	227	243	710	540	45
ACQ40014D	456	572	730	315	795	227	243	710	540	46
ACQ50014D	575	769	918	500	1006	286	326	898	735	77

## Performance Curves

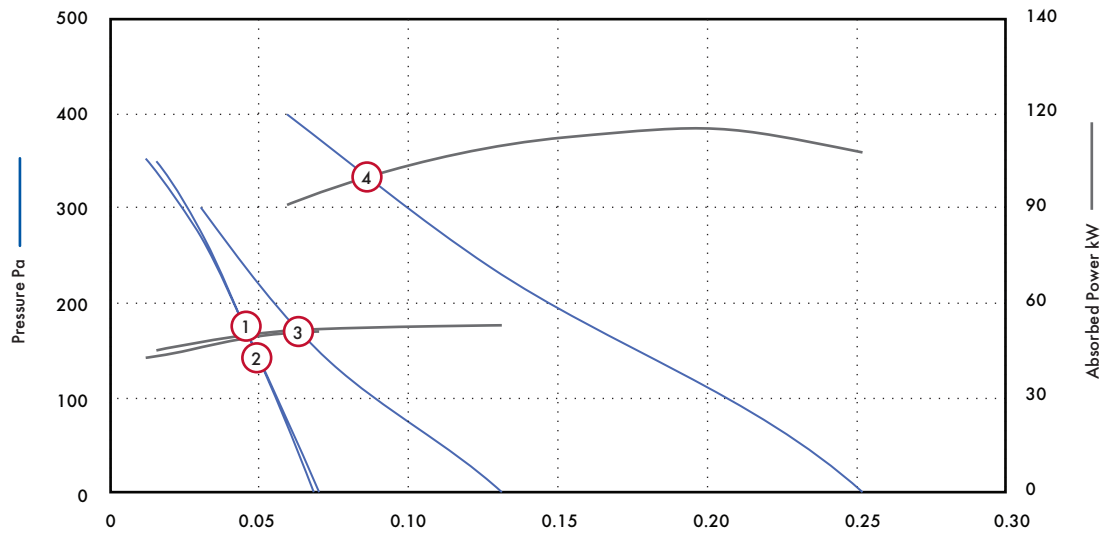

Motor Phase	Stock Ref	r.p.m	Curve Ref.	Airflow, m <sup>3</sup> /s @ Pa							Motor kW	S.C. Amps	F.LC Amps	dBA @ 3m	
				0	50	100	150	200	300	400					
1	ACQ10012D	2350	1	m <sup>3</sup> /s	0.07	0.06	0.06	0.05	0.04	0.03	0.05	0.37	0.23	31	
				kW	0.05	0.05	0.05	0.05	0.05	0.05					
1	ACQ12512D	2350	2	m <sup>3</sup> /s	0.07	0.06	0.06	0.05	0.04	0.02	0.05	0.37	0.23	32	
				kW	0.05	0.05	0.05	0.05	0.05	0.05					
1	ACQ15012D	2350	3	m <sup>3</sup> /s	0.13	0.11	0.09	0.07	0.06		0.05	0.37	0.23	32	
				kW	0.05	0.05	0.05	0.05	0.05						
1	ACQ16012D	2350	3	m <sup>3</sup> /s	0.13	0.11	0.09	0.07	0.06		0.05	0.37	0.23	32	
				kW	0.05	0.05	0.05	0.05	0.05						
1	ACQ20012D	2700	4	m <sup>3</sup> /s	0.25	0.23	0.21	0.18	0.15	0.10	0.06	0.09	0.85	0.38	34
				kW	0.11	0.11	0.11	0.11	0.11	0.10	0.09				

## Sound Data

Stock Ref	Spectrum	63	125	250	500	1k	2k	4k	8k	dBA @ 3m
ACQ10012D	Inlet	53	59	68	58	50	45	34	33	41
	Outlet	54	57	63	59	60	54	49	42	43
	Breakout	46	51	58	48	41	38	31	32	31
ACQ12512D	Inlet	51	65	73	62	51	46	36	36	45
	Outlet	52	62	67	64	62	55	52	45	46
	Breakout	48	52	59	49	41	40	33	32	32
ACQ15012D	Inlet	54	60	70	59	52	46	38	36	42
	Outlet	56	58	63	58	59	56	49	43	43
	Breakout	48	52	58	51	43	38	31	33	32
ACQ16012D	Inlet	54	60	70	59	52	46	38	36	42
	Outlet	56	58	63	58	59	56	49	43	43
	Breakout	48	52	58	51	43	38	31	33	32
ACQ20012D	Inlet	60	65	63	68	58	55	54	46	46
	Outlet	60	63	68	72	68	67	62	53	53
	Breakout	53	58	57	55	46	41	35	34	34

## Performance Curves

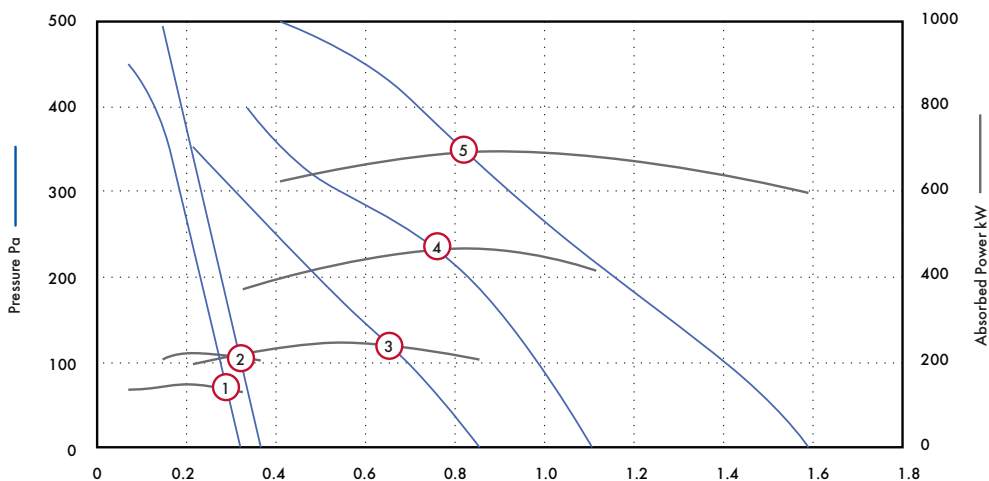

Motor Phase	Stock Ref	r.p.m	Curve Ref.	Airflow, m³/s @ Pa								Motor kW	S.C. Amps	F.L.C Amps	dBA @ 3m
				0	50	100	150	200	300	400					
1	ACQ25012D	2500	1	m³/s	0.32	0.30	0.27	0.25	0.23	0.18	0.13	0.16	1.25	0.68	34
				kW	0.13	0.14	0.14	0.14	0.15	0.15	0.14				
1	ACQ31512LD	2700	2	m³/s	0.37	0.35	0.32	0.30	0.27	0.23	0.19	0.23	2.4	0.97	36
				kW	0.20	0.21	0.21	0.22	0.22	0.22	0.22				
1	ACQ31514HD	1330	3	m³/s	0.85	0.78	0.69	0.59	0.49	0.30		0.27	2.2	1.18	36
				kW	0.21	0.22	0.24	0.24	0.24	0.22					
1	ACQ40014D	1340	4	m³/s	1.11	1.05	0.99	0.92	0.83	0.55	0.34	0.47	5.9	2.33	38
				kW	0.42	0.44	0.46	0.47	0.47	0.44	0.37				
1	ACQ50014D	1330	5	m³/s	1.59	1.51	1.40	1.28	1.15	0.92	0.72	0.73	6.27	3.21	46
				kW	0.60	0.62	0.64	0.66	0.68	0.70	0.69				

## Sound Data

Stock Ref	Spectrum	63	125	250	500	1k	2k	4k	8k	dBA @ 3m
ACQ25012D	Inlet	64	74	72	67	57	55	56	53	48
	Outlet	64	74	75	69	70	71	65	64	56
	Breakout	52	57	68	52	44	40	36	38	39
ACQ31512LD	Inlet	72	69	79	67	63	62	60	61	52
	Outlet	69	68	74	70	70	71	66	70	56
	Breakout	60	61	67	56	55	51	44	42	41
ACQ31514HD	Inlet	66	78	68	60	52	49	42	40	45
	Outlet	67	75	77	71	69	62	56	49	53
	Breakout	53	67	61	52	47	41	34	33	36
ACQ40014D	Inlet	73	82	79	68	62	55	50	49	52
	Outlet	72	78	78	75	74	66	58	53	57
	Breakout	57	68	61	56	51	45	39	34	38
ACQ50014D	Inlet	77	85	78	71	64	62	54	52	54
	Outlet	74	83	82	78	77	72	64	58	61
	Breakout	66	78	71	62	56	49	42	41	46

Accessories



Size	Std Fan Stock Ref	Electronic Controller Stock Ref	Auto Transformer Stock Ref	eDemand Voltage Control Stock Ref
100	ACQ10012D	SC5001	10314103	444164
125	ACQ12512D	SC5001	10314103	444164
150	ACQ15012D	SC5001	10314103	444164
160	ACQ16012D	SC5001	10314103	444164
200	ACQ20012D	SC5001	10314103	444164
250	ACQ25012D	SC5001	10314103	444164
315	ACQ31512LD	SC5030	10314103	444164
315	ACQ31514HD	SC5030TK	10314103	444164
400	ACQ40014D	SC5060TK	10314105	444164
500	ACQ50014D	SC5060TK	10314105	444164



Size	* Anti- Vibration Mounts (each) Stock Ref	Duct Air Heater Stock Ref	Filter Cassette Stock Ref	Bag Filter Cassette Stock Ref	Flexible Connections Stock Ref
100	68MP033G	10531100T1	10532100	10533100	FLX100
125	68MP033G	10531125T1	10532125	10533125	FLX125
150	68MP033G	10531150T1	10532150	10533150	FLX150
160	68MP033G	-	10532160A	10533160	FLX160
200	68MP033G	10531200T1	10532200	10533200	FLX200
250	68MP033G	10531250T1	10532250	10533250	FLX250
315	68MP033G	10531315T1	10532315	10533315	FLX315
400	68MP033G	10531400T3	10532400	10533400	FLX400
500	68MP033G	10531500T3	10532500A	10533500	FLX500

## Accessories



Size	Backdraught Shutter	Fast Clamp	Duct Attenuator			
	Stock Ref	Stock Ref	300mm Stock Ref	600mm Stock Ref	900mm Stock Ref	1200mm Stock Ref
100	10542100	10540100	10534100	10535100	10536100	-
125	10542125	10540125	10534125	10535125	10536125	-
150	10542150	10540150	10534150	10535150	10536150	-
160	-	10540160	-	10535160	-	-
200	10542200	10540200	-	10535200	10536200	10537200
250	10542250	10540250	-	10535250	10536250	10537250
315	10542315	10540315	-	10535315	10536315	10537315
400	10542400	10540400	-	10535400	10536400	10537400
500	-	-	-	-	10536500	-



# Eco Mixed Flow (eMF)

- High efficiency Mixed Flow Fan with guide vanes
- Available in sizes 355 to 710mm dia.
- IP54 Fan rating (duct mounted)
- Operating temperatures up to 80°C (see technical specification)
- Maintenance free, long life bearings
- All units suitable for speed control
- Quality Assurance to BS EN ISO 9001:2015



## Energy Saver

The 'eMF' high efficiency in-line mixed flow duct fans are designed around a high efficiency, high pressure development mixed flow impellor, offering a very compact design with high performance and low sound levels.

The in-line fan is constructed from steel and incorporates an aerodynamically designed airflow guide vane to ensure maximum performance from the unit.

All models offer minimum space requirements for installation and are designed for simple installation into duct ventilation systems via the included mounting foot. All units are suitable for vertical or horizontal mounting.

The eMF range is available in 15 models, covering sizes 355, 400, 450, 500, 560, 630 & 710mm diameter. The range shall provide a performance from 0.06m<sup>3</sup>/s to 5.63m<sup>3</sup>/s with a maximum pressure development of up to 1200 Pa.

## Impellers

The impellers are aerodynamically designed high efficiency mixed flow type, manufactured from steel or polyamide. The motor and impeller is factory matched, statically and dynamically balanced to ISO 1940, Grade G 2.5.

## Motors

All sizes are protected to IP54 in accordance with BS EN 60529:1992. With motors suitable for operating temperatures up to 80°C (see technical data). The range incorporates maintenance free motors, fitted with sealed for life ball bearings, ideally suited for speed control. Single phase 230V units by auto transformer control, 3 phase 230V or 400V by frequency inverters.

Motor protection by means of a thermal contact switch incorporated within the windings is provided to prevent motor damage due to overloading/overheating.

## Terminal Box

All single phase units are supplied with an IP44 terminal box as standard. All three phase units are supplied with a 2m long flying lead.

## Performance

The fan performance is in accordance with tests to BS848 Part 1 1980, with the fan sound levels measured in a reverberant chamber in accordance with BS848 Part 2 1985.

## Quality Assurance

Design and manufacture is in accordance with the standard for quality management systems BS EN ISO 9001:2015.

## Accessories

A full range of accessories are available with the eMF in-line mixed flow duct fans such as:

- Fast Clamps
- Auto Transformer Speed Controllers
- Frequency Inverters
- D.O.L. Starters and Overloads

## Fan Dimensions (mm)

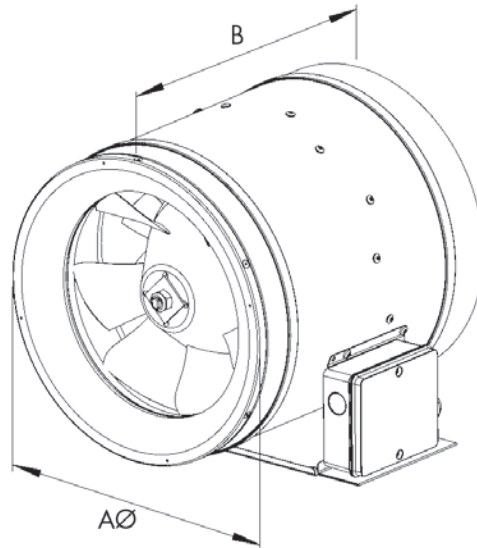

Stock Ref	AØ	B	Weight kg
EMF35514	355	396	13.5
EMF35512	354	396	17.3
EMF40014	403	417	12.8
EMF45014	453	467	18.4
EMF50014	504	515	23.2
EMF56014	564	582	38.0
EMF63014	634	655	43.1
EMF35532	354	396	17.5
EMF40034	403	417	14.8
EMF45034	453	467	18.9
EMF50034	504	515	23.6
EMF40032	403	417	20.3
EMF56034	564	582	28.0
EMF63034	634	654	39.3
EMF71034	714	732	49.0

## Performance Curve

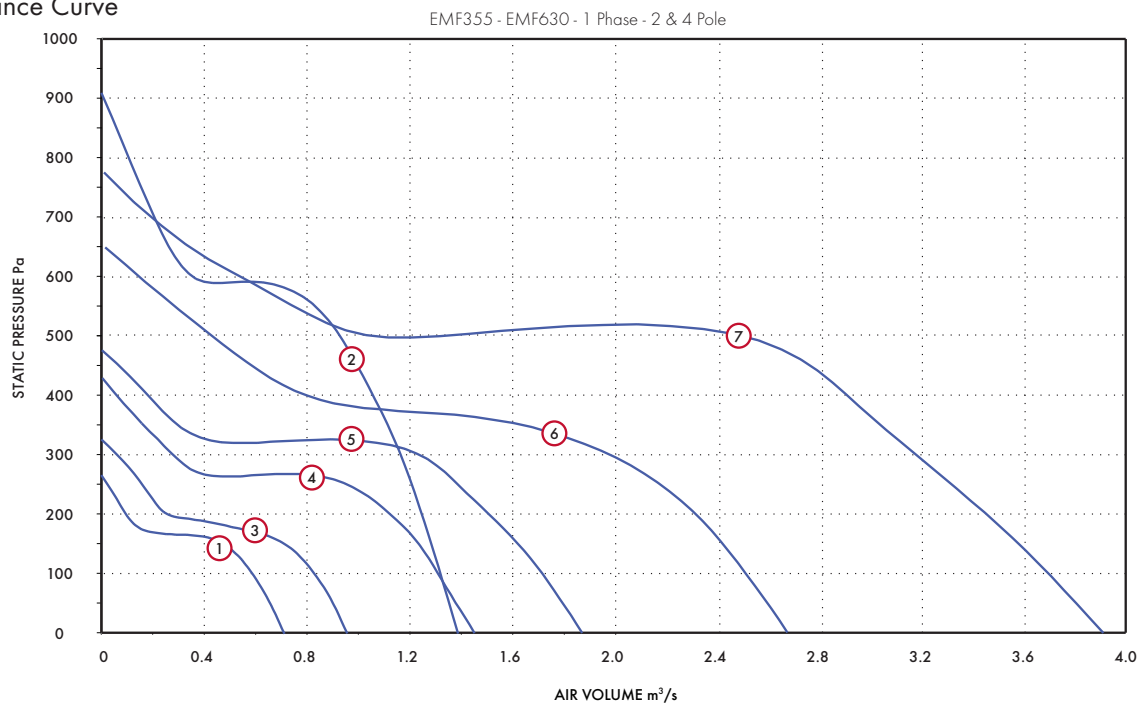

## Performance Guide

Stock Ref	rpm	Max Temp °C	Curve Ref	m³/s at Pa										Voltage	Max Watts	S.C. Amps	F.L.C. Amps
				0	100	200	300	400	500	600	700	800	900				
EMF35514	1460	45	1	0.71	0.58	0.09								230V/1/50	150	3.0	1.2
EMF35512	2850	80	2	1.39	1.32	1.24	1.16	1.05	0.92	0.35	0.20	0.10	0.01	230V/1/50	950	13.5	5.4
EMF40014	1460	80	3	0.95	0.82	0.25	0.06							230V/1/50	210	3.8	1.5
EMF45014	1450	80	4	1.45	1.31	1.12	0.28	0.06						230V/1/50	450	7.8	3.1
EMF50014	1380	80	5	1.87	1.71	1.50	1.25	0.18						230V/1/50	1380	9.3	3.7
EMF56014	1430	80	6	2.67	2.51	2.31	1.97	0.78	0.42	0.12				230V/1/50	1110	19.0	7.6
EMF63014	1410	50	7	3.89	3.69	3.43	3.18	2.90	2.49	0.54	0.19			230V/1/50	2140	28.5	11.4

## Sound Data

Stock Ref		125	250	500	1k	2k	4k	8k	dBa @3m
EMF35512	INLET	49	72	74	79	78	77	71	40
	OUTLET	55	74	80	83	81	77	69	40
	BREAKOUT	49	56	60	61	59	58	49	40
EMF35514	INLET	51	57	61	62	63	63	48	26
	OUTLET	56	60	66	67	64	60	47	26
	BREAKOUT	42	41	43	46	43	46	29	26
EMF40014	INLET	57	60	70	68	69	64	53	35
	OUTLET	65	63	73	73	69	65	54	35
	BREAKOUT	50	46	59	59	53	52	41	35
EMF45014	INLET	64	66	69	71	74	69	57	42
	OUTLET	71	69	77	76	74	70	59	42
	BREAKOUT	57	69	67	65	61	57	43	42
EMF50014	INLET	69	69	72	73	73	69	57	41
	OUTLET	74	75	78	77	74	70	59	41
	BREAKOUT	54	66	65	64	61	59	42	41
EMF56014	INLET	72	77	79	79	78	74	63	49
	OUTLET	76	82	85	81	79	76	65	49
	BREAKOUT	70	77	75	69	68	63	52	49
EMF63014	INLET	74	78	82	82	80	78	66	50
	OUTLET	74	82	86	84	81	78	67	50
	BREAKOUT	70	74	76	72	70	65	53	50

## Performance Curve

EMF355 - EMF500 - 3 Phase - 2 & 4 Pole

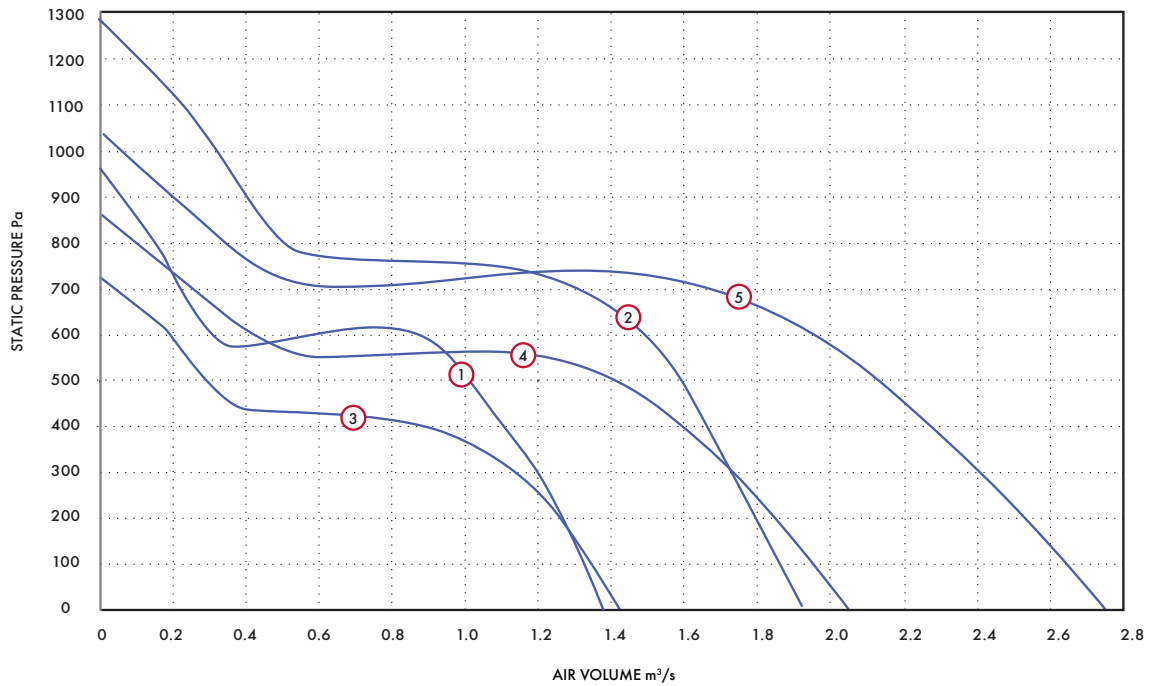

## Performance Guide

Stock Ref	rpm	Max Temp °C	Curve Ref	m <sup>3</sup> /s at Pa							Voltage	Max Watts	S.C. Amps	F.L.C. Amps
				0	200	400	600	800	1000	1200				
EMF35532	2910	60	1	1.38	1.27	1.10	0.88	0.15			230V/3/50	910	8.0	3.2
EMF40032	2930	80	2	1.92	1.85	1.66	1.49	0.51	0.32	0.11	400V/3/50	1540	8.0	3.2
EMF40034	2200	80	3	1.43	1.26	0.88	0.19				230V/3/75	650	6.8	2.7
EMF45034	2150	80	4	2.04	1.84	1.60	0.42				230V/3/70	1200	11.0	4.4
EMF50034	2060	70	5	2.75	2.53	2.27	1.96	0.34			230V/3/70	1920	17.8	7.1

## Sound Data

Stock Ref		125	250	500	1K	2K	4K	8K	dBa @3m
EMF35532	INLET	52	75	77	79	78	77	74	43
	OUTLET	56	76	85	85	82	78	71	43
	BREAKOUT	52	60	66	64	60	61	53	43
EMF40032	INLET	73	88	84	84	85	82	80	55
	OUTLET	76	89	93	91	87	84	80	55
	BREAKOUT	72	88	81	75	71	69	62	55
EMF40034	INLET	68	82	77	77	77	74	66	43
	OUTLET	69	85	86	84	79	76	68	43
	BREAKOUT	59	59	68	66	62	60	51	43
EMF45034	INLET	72	84	81	79	78	77	69	46
	OUTLET	74	87	88	84	81	79	71	46
	BREAKOUT	65	69	72	68	63	62	52	46
EMF50034	INLET	61	81	82	83	81	79	72	53
	OUTLET	71	81	89	89	86	82	74	53
	BREAKOUT	77	77	79	75	70	68	61	53

## Performance Curve

EMF560 - EMF710 - 3 Phase - 2 & 4 Pole

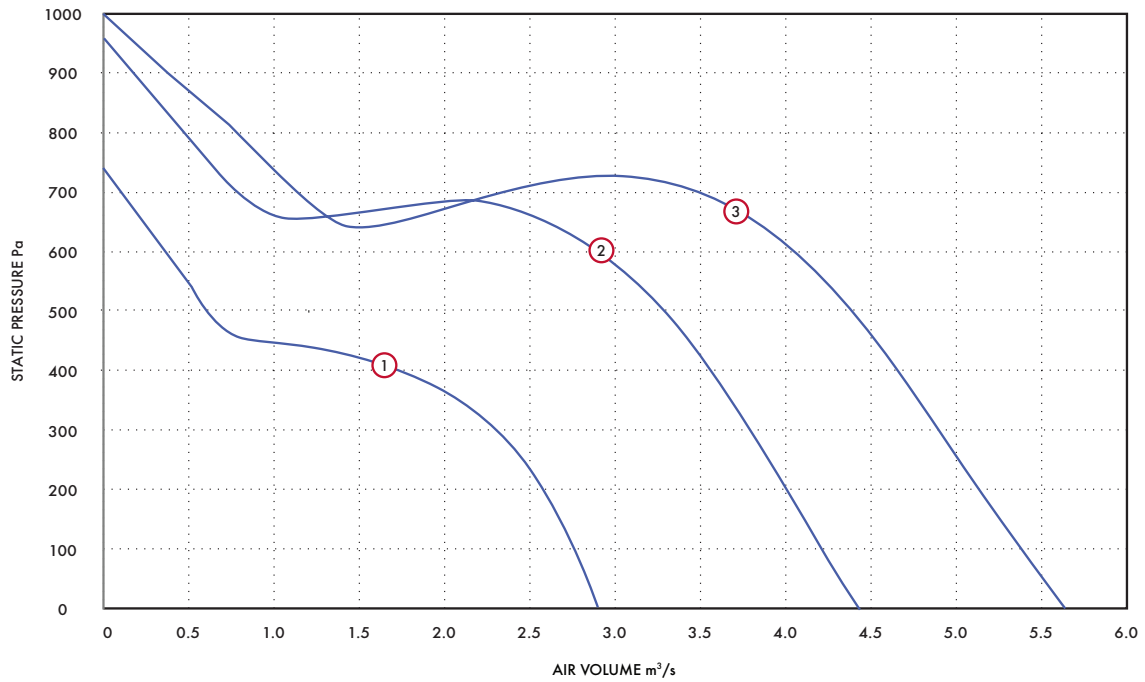

## Performance Guide

Stock Ref	rpm	Max Temp °C	Curve Ref	m³/s at Pa					Voltage	Max Watts	S.C. Amps	F.L.C. Amps
				0	200	400	600	800				
EMF56034	1570	80	①	2.90	2.57	1.73	0.37		400V/3/50	1360	7.0	2.8
EMF63034	1590	70	②	4.43	4.00	3.56	2.90	0.47	400V/3/50	2620	13.5	5.4
EMF71034	1440	55	③	5.63	5.13	4.66	4.05	0.78	400V/3/50	3610	19.3	7.7

## Sound Data

Stock Ref		125	250	500	1K	2K	4K	8K	dBa @3m
EMF56034	INLET	72	74	78	80	78	75	63	48
	OUTLET	74	84	83	82	80	76	65	48
	BREAKOUT	59	67	74	71	68	63	51	48
EMF63034	INLET	76	77	85	83	81	80	68	51
	OUTLET	76	83	88	85	83	80	69	51
	BREAKOUT	67	69	77	73	71	66	55	51
EMF71034	INLET	74	84	85	87	83	80	69	54
	OUTLET	75	87	90	89	86	81	71	54
	BREAKOUT	68	77	78	78	74	66	58	54

## Accessories



Fan			Auto Transformer	
Stock Ref	Voltage/Hz	FLC	Stock Ref	Stock Ref
EMF35512	230/1/50	5.4	10314107	VM355
EMF35514	230/1/50	1.2	10314103	VM355
EMF40014	230/1/50	1.5	10314103	VM400
EMF45014	230/1/50	3.1	10314105	VM450
EMF50014	230/1/50	3.7	10314105	VM500
EMF56014	230/1/50	7.6	10314113	VM560
EMF63014	230/1/50	11.4	10314113	VM630
*EMF35532	230/3/50	3.2	-	VM355
EMF40032	400/3/50	3.2	-	VM400
*EMF40034	230/3/75	2.7	-	VM400
*EMF45034	230/3/70	4.4	-	VM450
*EMF50034	230/3/70	7.1	-	VM500
EMF56034	400/3/50	2.8	-	VM560
EMF63034	400/3/50	5.4	-	VM630
EMF71034	400/3/50	7.7	-	VM710

\*Item available to special order and must be operated with a single phase in three phase out inverter. Please enquire.

# Powerflow In-Line Duct Fans (ACP)

- Tough plastic in-line range in seven models
- 50-80mm long ribbed spigots
- Flame retardant casing
- All models speed controllable
- Fitted with Standard Thermal Overload Protection (S.T.O.P.)
- Manufacture controlled to BS EN ISO 9001:2015
- Performance tested to BS 848 Part1 & 2
- 2 Year Warranty



## Ducted Ventilation

Powerflow models provide a compact yet versatile range designed with the installer in mind, combining the acoustic benefits of a tough plastic casing with the pressure characteristics of a centrifugal fan.

A range of seven models from 100 to 315mm dia. duct sizes. The 315mm dia. model has been specifically developed for use with rigid ductwork. Air volumes from 0.059m<sup>3</sup>/s to 0.42m<sup>3</sup>/s in free air and capable of pressure development up to 550 Pa.

Powerflow has 50-80mm long inlet and discharge spigots allowing easy installation and fixing. The adjustable mounting foot allows the terminal box to be rotated to any angle and allows plenty of space and adjustment for screw fixing. The robust fire-retardant polymeric casing combined with internal guide vanes ensures optimum airflow management through the unit.

---

## Electrical

Motors are 220-240V single phase 50Hz. Capacitor start and run. The terminal box is integral with the case moulding. All motors are fitted with Standard Thermal Overload Protection (S.T.O.P.).

---

## Motor/Impellers

All models are fitted with an external rotor motor and backward curved impeller assembly for long life and reliability.

All sizes are IP44 according to BS EN 60529. Ball bearings are greased for life and designed to run at any angle. Insulation is Class 'B' (from -30°C to +40°C). Manufacture is controlled to BS EN ISO 9001:2015.

---

## Accessories

A full range of accessories are available with the Powerflow in-line centrifugal duct fans such as:

- Electronic Speed Controllers
- Auto Transformer Speed Controllers
- D.O.L. Starters
- Pre & Secondary Filter Cassettes
- Electric Heater Batteries
- In-Line Attenuators
- Backdraught Shutters
- Fast Clamps

## Typical Installation

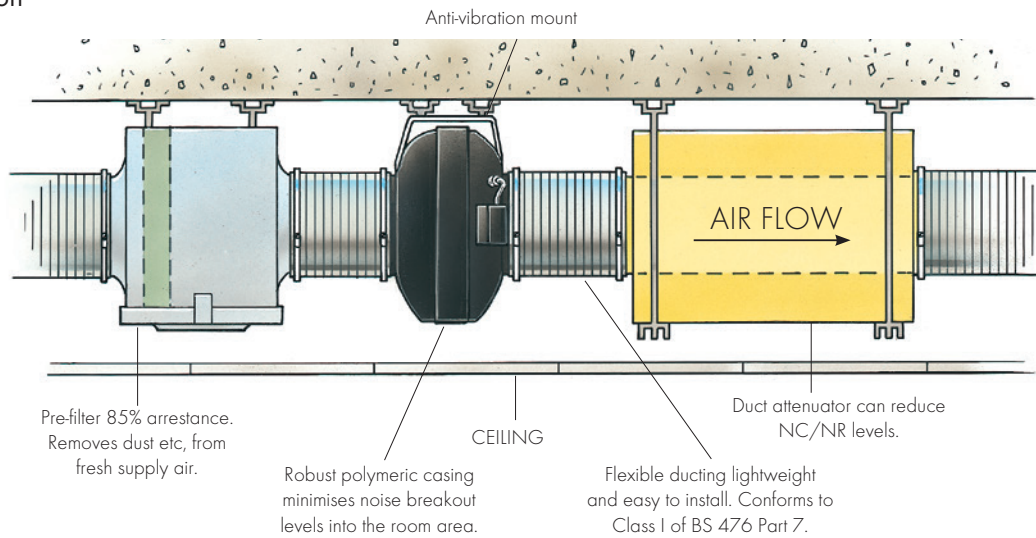

## Fan Dimensions (mm)

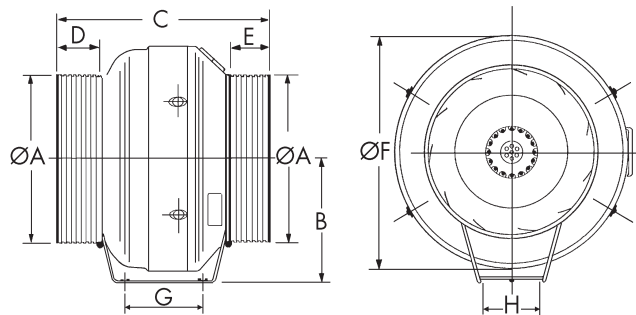

Dia	Øa	b	c	d	e	Øf	g	h	Weight kg
100*	100	146	287	52	52	254	110	270*	2.2
125*	125	146	287	60	60	254	110	270*	2.2
150*	149	175	287	52	52	301	110	270*	3.1
160*	160	175	287	52	52	301	110	270*	3.1
200	200	193	290	47	47	344	92	130	4.3
250	250	218	312	65	65	367	92	130	4.6
315	315	250	366	76	76	405	92	130	5.9

\*Sizes 100, 125, 150 & 160 have a flat mounting foot



# Performance Guide

100 to 315 dia. - 1 Phase - 2 Pole

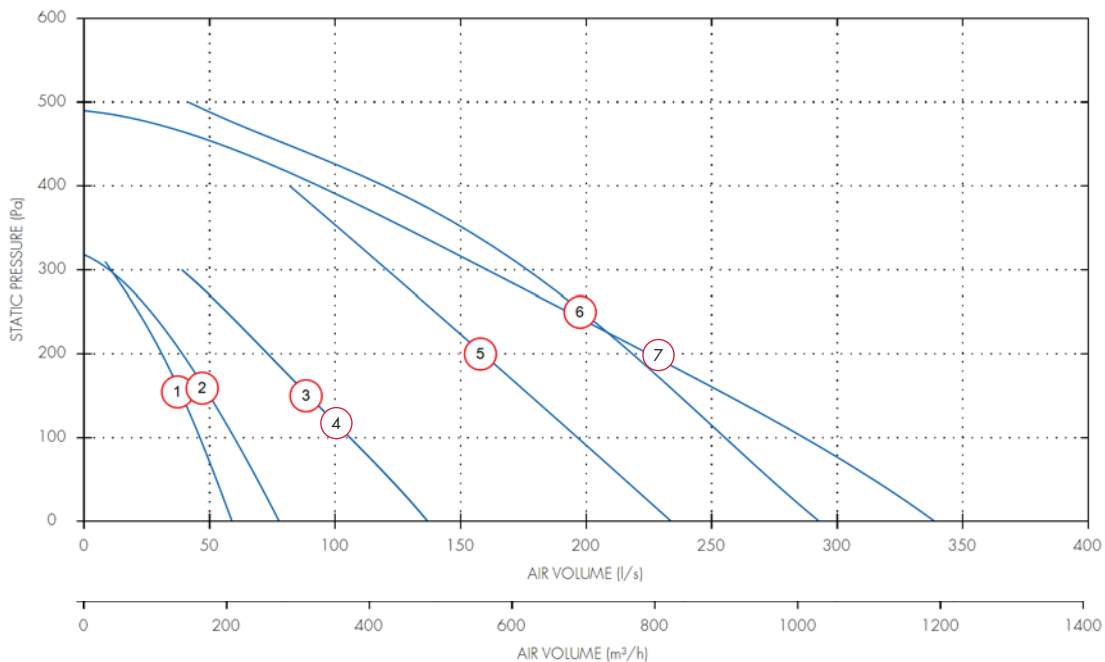

Dia.	Motor Phase	Stock Ref	r.p.m	IP Rating	Curve Ref.	l/s at Pa					Motor kW	S.C. Amps	F.L.C Amps	dBA @ 3m
						0	100	200	300	400				
100	1	ACP10012	2740	IP44	1	60	50	30	10		0.08	0.85	0.34	35
125	1	ACP12512	2410	IP44	2	80	60	40	10		0.08	0.85	0.34	35
150	1	ACP15012	2520	IP44	3	140	110	70	40		0.1	1.1	0.43	45
150	1	ACP16012	2520	IP44	4	140	110	70	40		0.1	1.1	0.43	45
200	1	ACP20012	2620	IP44	5	230	200	160	120		0.15	1.52	0.68	47
250	1	ACP25012	2720	IP44	6	290	260	220	180	120	0.19	1.6	0.77	48
315	1	ACP31512	2720	IP44	7	340	290	220	160	90	0.18	1.57	0.75	51

## Sound Data

Dia.	Motor Phase	Stock Ref.	Spectrum	63	125	250	500	1k	2k	4k	8k	dBA @ 3m
100	1	ACP10012	Outlet	82	84	77	68	61	52	49	43	52
100	1	ACP10012	Breakout	52	48	57	53	53	48	40	38	36
125	1	ACP12512	Inlet	80	79	76	70	61	57	51	45	51
125	1	ACP12512	Outlet	82	80	76	71	61	54	51	43	52
125	1	ACP12512	Breakout	52	48	57	53	53	48	40	38	36
150	1	ACP15012	Inlet	79	84	84	76	69	65	61	52	58
150	1	ACP15012	Outlet	78	84	83	74	69	65	60	50	57
150	1	ACP15012	Breakout	59	62	66	62	62	58	51	43	45
150	1	ACP16012	Inlet	81	81	79	76	66	61	58	49	55
150	1	ACP16012	Outlet	80	82	81	73	67	62	57	49	55
150	1	ACP16012	Breakout	59	62	66	62	62	58	51	43	45
200	1	ACP20012	Inlet	80	79	74	76	67	65	66	60	55
200	1	ACP20012	Outlet	79	79	74	71	69	69	65	59	55
200	1	ACP20012	Breakout	54	70	67	66	62	59	53	43	47
250	1	ACP25012	Inlet	84	80	74	74	69	69	67	63	56
250	1	ACP25012	Outlet	75	79	73	72	72	73	68	64	58
250	1	ACP25012	Breakout	60	71	70	66	65	62	55	44	49
315	1	ACP31512	Inlet	84	80	74	74	69	69	67	63	56
315	1	ACP31512	Outlet	75	79	73	72	72	73	68	64	58
315	1	ACP31512	Breakout	72	71	73	71	66	63	55	45	52

## Accessories



Stock Ref	Electronic Controller	Auto Transformer	D.O.L. Starter & Coil	*eDemand Controller			†Duct Air Heater	Filter Cassette	Bag Filter Cassette
	Stock Ref	Stock Ref	Stock Ref	Voltage Control	1/3 Phase Inverter	3 Phase Inverter	Stock Ref	Stock Ref	Stock Ref
ACP10012	W10303102M	10314103	444744 + 444697	444164	-	-	10531100T1	10532100	10533100
ACP12512	W10303102M	10314103	444744 + 444697	444164	-	-	10531125T1	10532125	10533125
ACP15012	W10303102M	10314103	444744 + 444698	444164	-	-	10531150T1	10532150	10533150
ACP16012	W10303102M	10314103	444744 + 444698	444164	-	-	-	-	-
ACP20012	W10303102M	10314103	444744 + 444699	444164	-	-	10531200T1	10532200	10533200
ACP25012	W10303102M	10314103	444744 + 444699	444164	-	-	10531250T1	10532250	10533250
ACP31512	W10303102M	10314103	444744 + 444699	444164	-	-	10531315T1	10532315	10533315

\*For full range of speed controller options, see Accessories & Controllers section



Stock Ref	Duct Attenuator				Heat Exchange Unit
	300mm	600mm	900mm	1200mm	
ACP10012	10534100	10535100	10536100	-	-
ACP12512	10534125	10535125	10536125	-	-
ACP15012	10534150	10535150	10536150	-	-
ACP16012	-	-	-	-	-
ACP20012	-	10535200	10536200	10537200	10538290
ACP25012	-	10535250	10536250	10537250	10538290
ACP31512	-	10535315	10536315	10537315	10538290

# EuroSeries (SDX)

- Available in sizes 100 to 315
- 200 and 250 sizes also available as high performance
- Motor Insulation Class B, protected to IP44
- Operating temperatures from -25°C up to +60°C
- All units suitable for speed control
- Quality Assurance to BS EN ISO 9001:2015
- Performance tested to BS848 Part 1 1980
- 2 Year Warranty

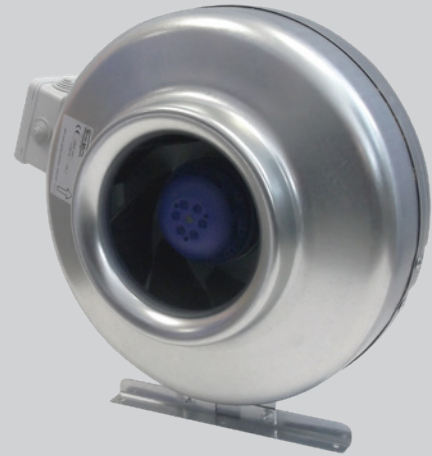

The SDX Euroflow in-line centrifugal duct fans are designed around an efficient backward curved centrifugal impeller and external rotor motor to ensure a compact design, high performance and low sound levels.

The in-line fan casing is constructed from pressed steel and incorporates an aerodynamically designed airflow guide vane, ensuring maximum performance from the unit whilst maintaining minimum noise levels. All models are supplied with a simple mounting foot for ease of installation.

The SDX range is available in eight model sizes: 100, 125, 150, 200, 250 & 315mm diameter as standard performance and sizes 200 and 250 also available as a high performance in-line centrifugal duct fan. The range provides a performance up to 0.372m<sup>3</sup>/s with a maximum pressure development of 500 Pa.

The SDX range is suitable for the extract of clean air only. It is not suitable for extracting or transporting grinding dust, soot, explosive or other aggressive gases etc.

---

## Impellers

The impellers are aerodynamically designed centrifugal backward curved type, manufactured by injection moulding of a polypropylene resin. The motor and impeller is factory matched, statically and dynamically balanced in two planes to ISO 1940, Grade G 6.3.

---

## Motors

All units are fitted with motors protected to IP44, insulation Class B and are suitable for temperatures ranging from -25°C to +60°C with humidity levels of up to 95% RH ensuring reliable operation. All sizes are for a 220V/1/50Hz electrical supply and incorporate a manual reset thermal protection device.

---

## Terminal Box

An IP54 terminal box fitted to the casing with multiple cable entry positions.

---

---

## Performance

The fan performance is in accordance with tests to BS848 Part 1 1980, with the fan sound levels measured in a reverberant chamber in accordance with BS848 Part 2 1985.

---

## Quality Assurance

Design and manufacture is in accordance with the standard for quality management systems BS EN ISO 9001:2015.

---

## Accessories

A full range of accessories are available with the Euroflow in-line centrifugal duct fans such as:

- Electronic Speed Controllers
- Auto Transformer Speed Controllers
- D.O.L. Starter and Overload
- Pre & Secondary Filter Cassettes
- Electric Heater Batteries
- In-line Attenuators
- Backdraught Shutters
- Fast Clamps
- Flexible Ducting
- Wall Terminals
- Roof Terminals

## Dimensions (mm)

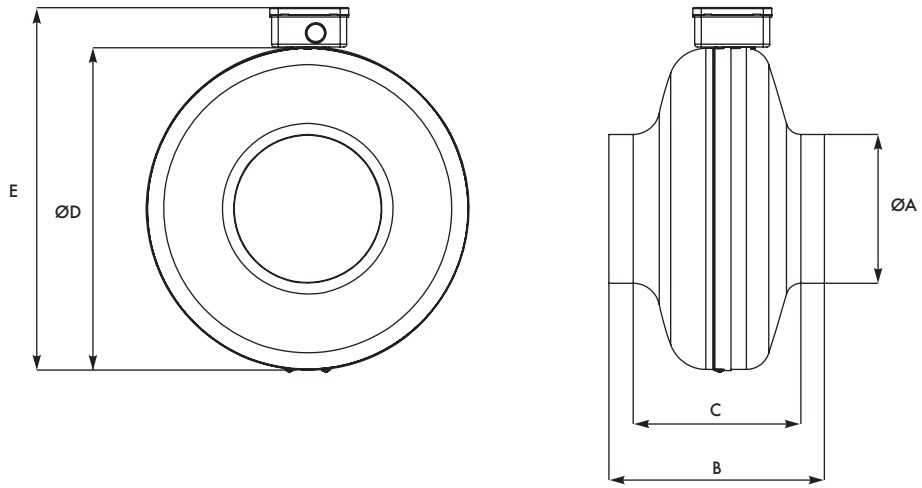

Unit Size	ØA	B	C	ØD	E	kg
SDX100	100	189	152	244	287	3
SDX125	125	182	143	243	286	3
SDX150	150	217	166	344	387	3
SDX200	200	219	167	344	387	4
SDX200H	200	231	179	344	387	4.7
SDX250	250	223	167	344	387	4
SDX250H	250	230	167	344	387	4.7
SDX315	315	243	175	402	444	5.6

## Performance Curves

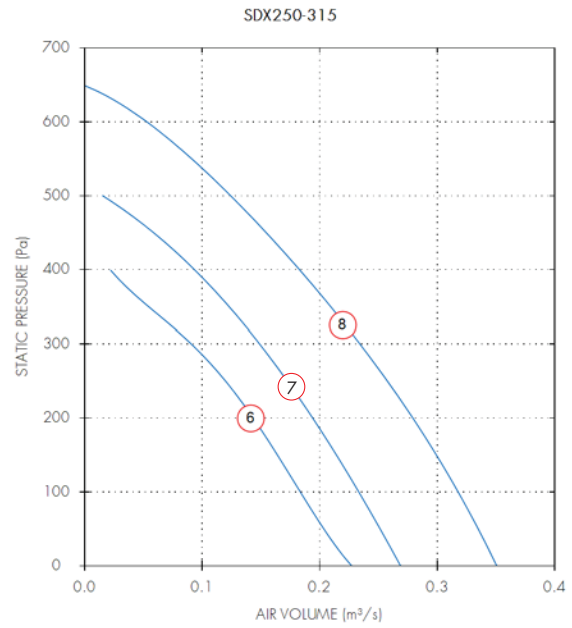
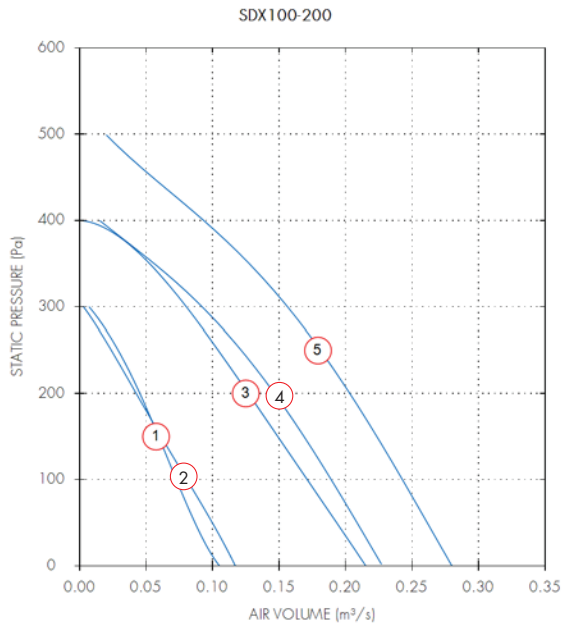

## Performance Guide

Dia.	Motor Phase	Stock Ref	r.p.m	IP Rating	Curve Ref.	m <sup>3</sup> /s @ Pa								Motor kW	F.L.C Amps	dBA @ 3m	
						0	100	200	300	400	500	600					
100	1	SDX100C	2800	IP44	1	0.11	0.07	0.05							0.07	0.31	26
125	1	SDX125C	2800	IP44	2	0.12	0.08	0.04							0.08	0.31	24
150	1	SDX150C	2800	IP44	3	0.22	0.17	0.13	0.08						0.1	0.44	35
200	1	SDX200C	2600	IP44	4	0.23	0.19	0.15	0.09						0.11	0.45	34
200	1	SDX200HC	2660	IP44	5	0.28	0.24	0.2	0.16	0.09					0.14	0.56	38
250	1	SDX250C	2600	IP44	6	0.23	0.18	0.14	0.09						0.11	0.45	31
250	1	SDX250HC	2460	IP44	7	0.27	0.23	0.19	0.15	0.09	0.02				0.13	0.56	34
315	1	SDX315C	2567	IP44	8	0.35	0.32	0.28	0.23	0.18	0.12	0.05			0.22	0.96	36

## Sound Power Level Spectra dB (ref 10<sup>-12</sup> Watts)

Dia.	Motor Phase	Stock Ref	Spectrum	dB								dBA @ 3m
				125	250	500	1k	2k	4k	8k		
100	1	SDX100C	Inlet	53	58	60	66	65	58	47	49	
100	1	SDX100C	Outlet	54	60	61	67	66	58	48	50	
100	1	SDX100C	Breakout	34	58	44	55	54	47	37	39	
125	1	SDX125C	Inlet	50	54	63	65	64	56	47	48	
125	1	SDX125C	Outlet	49	53	61	64	63	55	45	47	
125	1	SDX125C	Breakout	28	29	45	53	52	44	35	36	
150	1	SDX150C	Inlet	51	66	67	71	62	61	53	52	
150	1	SDX150C	Outlet	52	67	68	72	64	63	50	54	
150	1	SDX150C	Breakout	30	49	51	60	52	50	36	41	
200	1	SDX200C	Inlet	46	53	62	66	63	64	54	50	
200	1	SDX200C	Outlet	45	54	61	68	64	65	53	51	
200	1	SDX200C	Breakout	22	24	41	49	53	43	40	35	
200	1	SDX200HC	Inlet	53	60	66	69	66	65	63	53	
200	1	SDX200HC	Outlet	54	62	65	70	67	67	63	54	
200	1	SDX200HC	Breakout	25	35	46	53	55	47	45	38	
250	1	SDX250C	Inlet	41	52	61	66	66	64	56	51	
250	1	SDX250C	Outlet	43	53	60	68	67	65	57	52	
250	1	SDX250C	Breakout	24	30	38	48	47	45	40	32	
250	1	SDX250HC	Inlet	54	62	67	69	67	67	65	54	
250	1	SDX250HC	Outlet	55	63	66	70	68	67	65	54	
250	1	SDX250HC	Breakout	33	38	47	50	48	47	46	34	
315	1	SDX315C	Inlet	50	59	67	68	66	65	64	52	
315	1	SDX315C	Outlet	51	60	66	69	67	66	65	53	
315	1	SDX315C	Breakout	33	38	45	48	47	45	43	32	

## Models & Accessories

Fan Stock Ref	Speed Controller		Starter (requires Overload) Stock Ref	Overload Stock Ref
	Stock Ref	Stock Ref		
SDX100	SC5001	SPM5020	444744	444696
SDX125	SC5001	SPM5020	444744	444696
SDX150	SC5001	SPM5020	444744	444697
SDX200	SC5001	SPM5020	444744	444698
SDX200H	SC5001	SPM5020	444744	444699
SDX250	SC5001	SPM5020	444744	444698
SDX250H	SC5001	SPM5020	444744	444699
SDX315	SC5001	SPM5020	444744	444699

Dia	In-Line Attenuators			
	300mm Stock Ref	600mm Stock Ref	900mm Stock Ref	1200mm Stock Ref
100	83010030	83010060	83010090	-
125	83012030	83012060	83012090	-
150	83015030	83015060	83015090	-
200	-	83020060	83020090	83020120
250	-	83025060	83025090	83025120
315	-	83031060	83031090	83031120

Fan Stock Ref	Wall Terminal Stock Ref	Wall Terminal Stock Ref	Electric Heaters Stock Ref	Panel Filters Stock Ref
100	SA100/280	SA100/80	10531100T1	QPF100A
125	SA125/280	SA125/80	10531125T1	QPF125A
150	SA150/280	SA150/80	10531150T1	QPF150A
200	SA200/280	SA200/80	10531200T1	QPF200A
250	SA250/280	SA250/80	10531250T1	QPF250A
315	SA315/280	SA315/80	10531315T1	QPF315A

Fan Stock Ref	Bag Filters Stock Ref	Roof Terminal Stock Ref	Louvre Shutter Stock Ref
100	QPFB100A	WRC100	LS250
125	QPFB125A	WB160	LS250
150	QPFB150A	WB160	LS250
200	QPFB200A	WB200	LS250
250	QPFB250A	RCZ300	LS250
315	QPFB315A	RCZ300	LS315

# NEW Slimpak EC Box Fan (SLP EC)

- Ultra slim and compact
- Energy efficient EC/DC motor
- Backward curved impeller
- Acoustically treated 'O' class rated
- 'Eco Flow' computer modelled design
- Integral commissioning potentiometer
- Optional external speed control input
- Matching ancillaries



The New range of Slimpak EC single in-line box fans incorporate an energy efficient EC motor and basic commissioning controls to offer an energy efficient basic fan system.

Manufactured from Galvanised sheet the Slimpak (SLP EC) fan units are internally treated with an 'O' class rated, BS476 part 6 & 7, acoustic foam, which offers the benefits of high sound absorption and good thermal insulation properties, in addition to self extinguishing properties and resistance to ignition.

The casing includes an inclined inlet and bellmouth entry which directs the incoming air to the impeller with minimal turbulence. The result is better air management through the unit, less noise, higher efficiency and an increased performance.

The housing is designed to be as compact as possible for ceiling or plant room applications with integral mounting points to allow quick and easy installation.

---

## Motor / Impellers

All SLP EC units feature an energy efficient, Class 1, EC/DC external rotor motor and backward curved impeller assembly specifically chosen for performance and non-overloading characteristics. The assembly is dynamically balanced to DIN ISO 1940 Grade 6.3, duct size 500mm rated IP54, all other sizes, IP44 according to BS EN 60529. Ball bearings are greased for life. Insulation is Class 'B' (from -25°C to +60°C). All models incorporate internal electronic overload protection and soft start function.

---

## Control

Every SLP EC unit is fitted with a purpose designed integral commissioning controller giving the ability to set the exact duty required at commissioning. Alternatively the integral potentiometer can be bypassed to allow remote speed control via an external 0-10V potentiometer. Low voltage control wiring is kept separate from the mains wiring.

---

---

## Electrical

Motors are single phase 230V +/- 10% / 50/60Hz / 1ph (size 100-400mm) or 400V +/- 10% / 50/60Hz / 3ph (size 500mm).

---

## Performance/Sound

Extensively tested to BS848 parts 1 & 2. Published dB(A) figures are free field sound pressure levels at 3m with spherical propagation at reference level of 2 x 10<sup>-5</sup> Pa. The inlet/outlet sound power level spectra figures are dB with a reference of 10-12 watts.

---

## Quality Assurance

Design and manufacture are in accordance with the standard for quality management systems BS EN ISO 9001:2015.

---

## Accessories

A full range of accessories are available with the Slimpak EC range of fans such as:

- Remote potentiometer speed controller
  - Two speed trickle boost controller
  - Pre & secondary filter cassettes
  - Electric heater batteries
  - Backdraught shutters
  - In-line attenuators
-

Dimensions (mm)

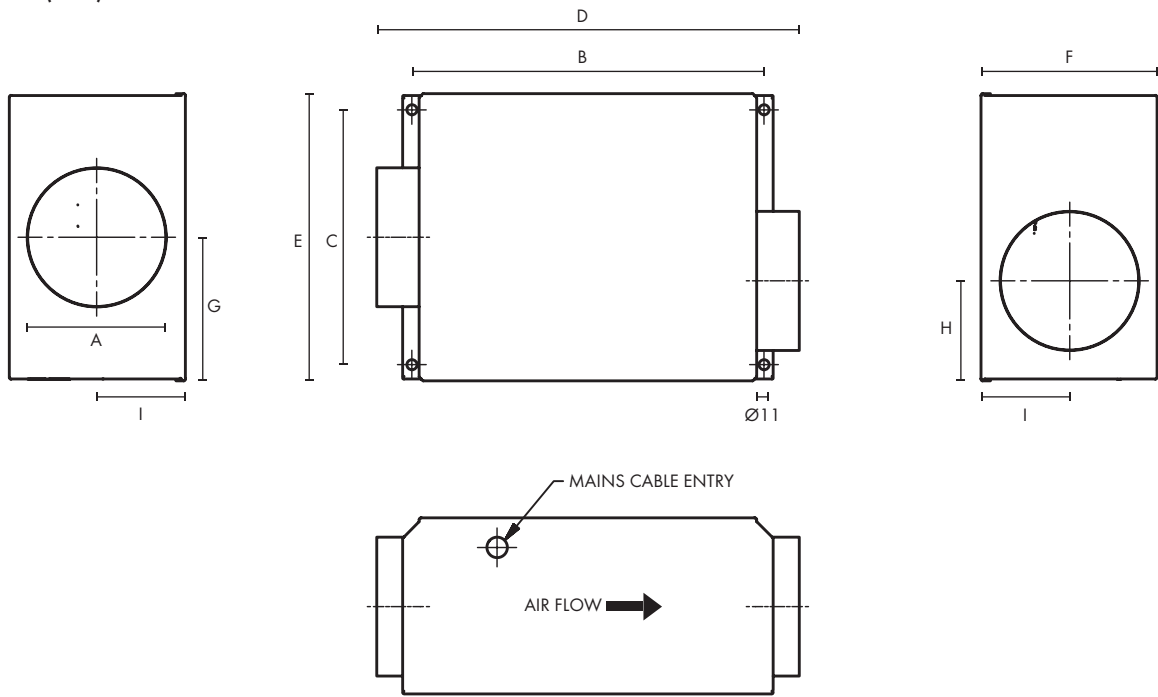

Stock Ref	A	B	C	D	E	F	G	H	I	kg
SLP100EC	100	380	275	456	310	192	155	108	96	7.5
SLP125EC	125	380	275	456	310	192	155	108	96	7.5
SLP150EC	150	380	275	456	310	192	155	108	96	7.5
SLP200EC	200	435	330	511	364	287	182	122	143	12
SLP250EC	250	435	330	511	364	287	182	122	143	13
SLP315EC	315	710	540	785	572	460	286	243	230	33
SLP400EC	400	710	540	785	572	460	286	243	230	36
SLP500EC	500	898	735	975	770	577	385	326	286	58



## Performance Guide

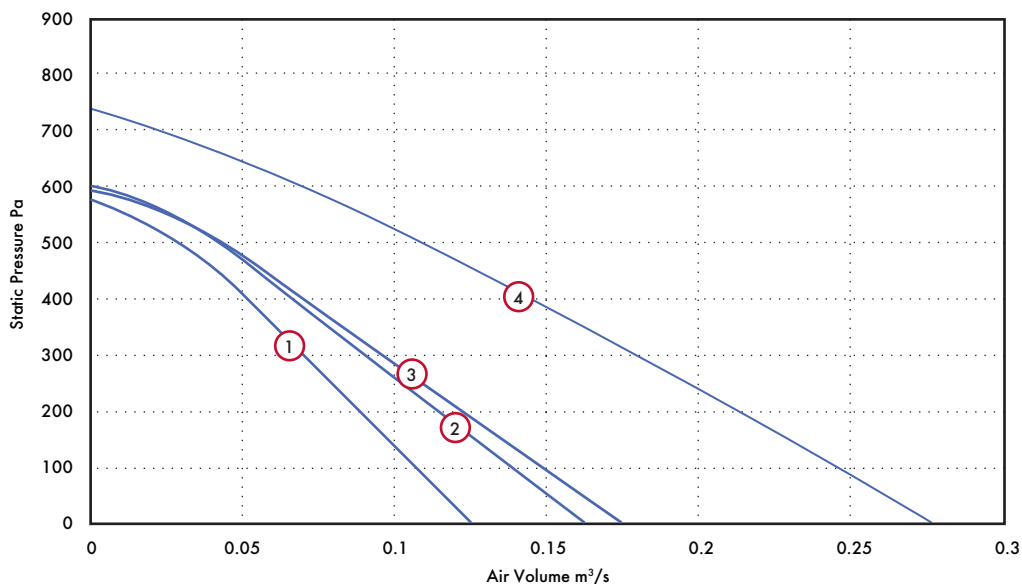

Dia.	Motor Phase	Stock Ref	IP Rating	Curve Ref.	m <sup>3</sup> /s @ Pa								S.C. Amps	F.L.C Amps	dB(A) @ 3m			
					0	100	200	300	400	500	600	700						
100	1	SLP100EC	IP44	1	m <sup>3</sup> /s	0.13	0.11	0.09	0.07	0.05	0.03							
					kW	0.08	0.08	0.08	0.08	0.08	0.08				0.72	0.72	36	
					W/l/s	0.64	0.76	0.92	1.15	1.54	2.69							
125	1	SLP125EC	IP44	2	m <sup>3</sup> /s	0.16	0.14	0.11	0.09	0.07	0.04							
					kW	0.08	0.08	0.08	0.08	0.08	0.08				0.72	0.72	37	
					W/l/s	0.50	0.58	0.72	0.92	1.24	1.95							
150	1	SLP150EC	IP44	3	m <sup>3</sup> /s	0.17	0.15	0.12	0.10	0.07	0.04							
					kW	0.08	0.08	0.08	0.08	0.08	0.08				0.74	0.74	39	
					W/l/s	0.46	0.54	0.66	0.85	1.17	1.94							
200	1	SLP200EC	IP44	4	m <sup>3</sup> /s	0.28	0.25	0.21	0.18	0.14	0.11	0.07	0.02					
					kW	0.15	0.16	0.17	0.17	0.17	0.17	0.17	0.16			0.72	0.72	42
					W/l/s	0.55	0.66	0.78	0.94	1.17	1.57	2.47	8.21					

## Sound Power Level Spectra dB (ref 10<sup>-12</sup> Watts)

Dia.	Motor Phase	Stock Ref	Spectrum	63	125	250	500	1k	2k	4k	8k	dB(A) @ 3m
100	1	SLP100EC	Inlet	57	62	68	71	58	52	47	41	48
			Outlet	57	63	71	72	66	62	55	48	51
			Breakout	64	63	60	55	47	46	44	38	36
125	1	SLP125EC	Inlet	58	69	70	70	60	56	48	42	48
			Outlet	58	70	71	73	70	67	60	52	54
			Breakout	62	58	59	57	52	46	37	33	37
150	1	SLP150EC	Inlet	59	68	72	76	64	58	51	48	53
			Outlet	59	70	74	76	71	70	64	58	57
			Breakout	62	61	59	60	54	49	43	37	39
200	1	SLP200EC	Inlet	68	71	72	77	70	63	61	57	56
			Outlet	70	72	69	80	76	76	72	65	62
			Breakout	63	69	66	60	53	51	50	50	42

## Performance Guide

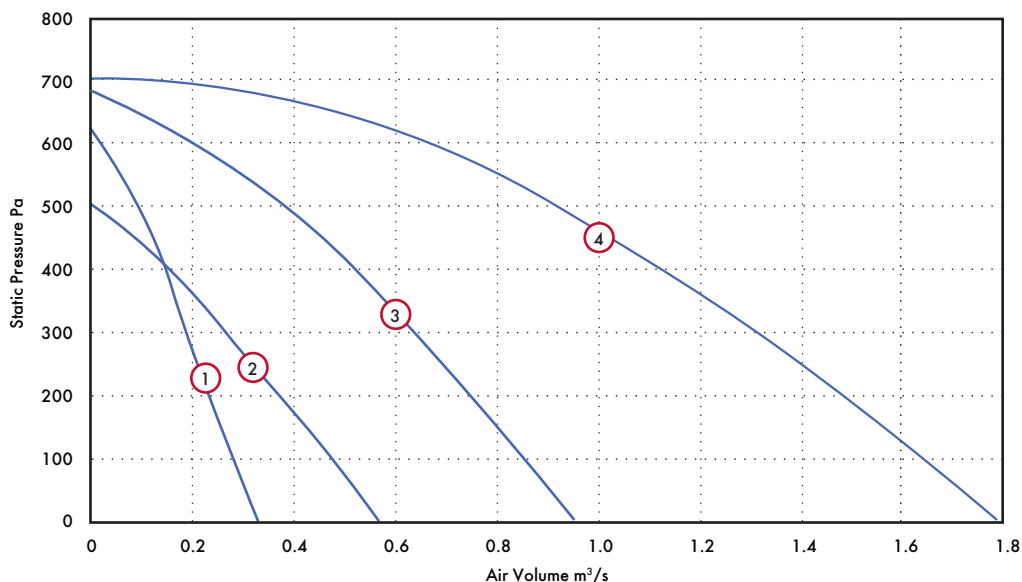

Dia.	Motor Phase	Stock Ref	IP Rating	Curve Ref.	m <sup>3</sup> /s @ Pa							S.C. Amps	F.L.C Amps	dB(A) @ 3m	
					0	100	200	300	400	500	600				
250	1	SLP250EC	IP44	1	m <sup>3</sup> /s	0.33	0.28	0.24	0.19	0.15	0.09		1.38	1.38	42
					kW	0.12	0.14	0.14	0.15	0.14	0.13				
					W/l/s	0.38	0.48	0.61	0.76	0.99	1.47				
315	1	SLP315EC	IP44	2	m <sup>3</sup> /s	0.57	0.48	0.37	0.26	0.15		1.36	1.36	44	
					kW	0.15	0.16	0.16	0.16	0.16					
					W/l/s	0.27	0.34	0.44	0.62	1.07					
400	1	SLP400EC	IP44	3	m <sup>3</sup> /s	0.95	0.85	0.75	0.64	0.52	0.38	0.20	2.47	2.47	48
					kW	0.40	0.42	0.44	0.44	0.44	0.42	0.36			
					W/l/s	0.42	0.49	0.58	0.69	0.84	1.09	1.83			
500	3	SLP500EC	IP54	4	m <sup>3</sup> /s	1.79	1.63	1.47	1.31	1.13	0.93	0.67	2.1	2.1	49
					kW	0.68	0.78	0.86	0.92	0.95	0.94	0.88			
					W/l/s	0.38	0.48	0.58	0.70	0.84	1.02	1.31			

## Sound Power Level Spectra dB (ref 10<sup>-12</sup> Watts)

Dia.	Motor Phase	Stock Ref	Spectrum	63	125	250	500	1k	2k	4k	8k	dB(A) @ 3m
250	1	SLP250EC	Inlet	68	71	72	80	68	62	59	56	57
			Outlet	68	71	70	78	75	75	68	63	60
			Breakout	61	63	62	62	55	54	52	45	42
315	1	SLP315EC	Inlet	67	78	79	66	61	58	53	45	52
			Outlet	66	78	78	73	70	68	63	55	56
			Breakout	62	69	69	56	53	47	43	36	42
400	1	SLP400EC	Inlet	78	83	87	73	69	66	61	54	59
			Outlet	78	85	92	80	79	75	69	61	66
			Breakout	67	73	76	63	58	50	44	40	48
500	3	SLP500EC	Inlet	88	93	86	80	71	67	59	53	62
			Outlet	87	91	89	84	83	78	68	62	67
			Breakout	74	80	76	67	61	54	44	36	50

## Models & Accessories



Fan Stock Ref	Remote Speed Control Stock Ref	Trickle/Boost Controller Stock Ref
SLP100EC	10520602	475775
SLP125EC	10520602	475775
SLP150EC	10520602	475775
SLP200EC	10520602	475775
SLP250EC	10520602	475775
SLP315EC	10520602	475775
SLP400EC	10520602	475775
SLP500EC	10520602	475775



Backdraught  
Shutter  
Stock Ref



Fast  
Clamp  
Stock Ref



Anti-Vibration  
Mounts (set of 4)  
Stock Ref

Size	Backdraught Shutter Stock Ref	Fast Clamp Stock Ref	Anti-Vibration Mounts (set of 4) Stock Ref
100	10542100	10540100	68MP033G
125	10542125	10540125	68MP033G
150	10542150	10540150	68MP033G
200	10542200	10540200	68MP033G
250	10542250	10540250	68MP033G
315	10542315	10540315	68MP033G
400	10542400	10540400	68MP033G
500	-	-	68MP033G



Duct Attenuator

Size	Duct Attenuator			
	300mm Stock Ref	600mm Stock Ref	900mm Stock Ref	1200mm Stock Ref
100	10534100	10535100	10536100	-
125	10534125	10535125	10536125	-
150	10534150	10535150	10536150	-
200	-	10535200	10536200	10537200
250	-	10535250	10536250	10537250
315	-	10535315	10536315	10537315
400	-	10535400	10536400	10537400
500	-	-	10536500	-

## Models & Accessories



Size	Duct Air Heater Stock Ref	Filter Cassette Stock Ref	Bag Filter Cassette Stock Ref	Flexible Connections Stock Ref
100	10531100T1	10532100	10533100	FLX100
125	10531125T1	10532125	10533125	FLX125
150	10531150T1	10532150	10533150	FLX150
200	10531200T1	10532200	10533200	FLX200
250	10531250T1	10532250	10533250	FLX250
315	10531315T1 10531315T3	10532315	10533315	FLX315
400	10531400T3	10532400	10533400	FLX400
500	10531500T3	10532500A	10533500	FLX500

# Square Mixed Flow Fans (MFQ)

- Motors protected to IP44
- Motor insulation Class 'B'
- Standard Thermal Overload Protection
- Doby flanging
- All models speed controllable
- Manufacture controlled to BS EN ISO 9001:2015
- Performance tested to ISO 5801
- In duct temperature up to 60°C (dependant on model)

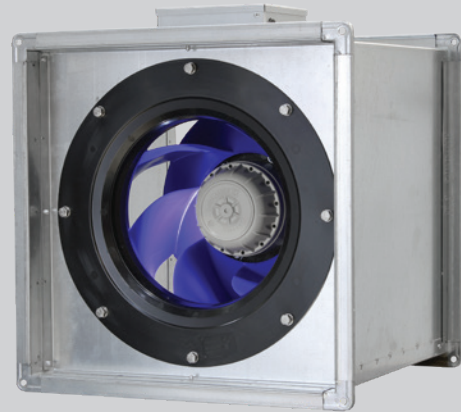

The Square Mixed Flow (MFQ) range has been specially designed for systems with high performance and low sound levels in mind. Ideal for commercial and industrial premises, the MFQ range places the emphasis on fast installation, reliable performance and easy access for maintenance.

The range offers almost two and a half times the pressure development of conventional axial fans and is an ideal cost effective alternative to two stage axial arrangements. The range is dimensionally compact, saving weight and installation costs.

Available in five sizes with a duty range from 0.632m<sup>3</sup>/s to 3.673m<sup>3</sup>/s (2275m<sup>3</sup>/h to 13,222m<sup>3</sup>/h), develops pressures up to 450 Pa.

## Mixed Flow Impeller and Casing

The high efficiency backward curved mixed flow impeller is manufactured in a moulded Polyamide material with 30% Glass Fibre. All other sizes of impeller are constructed in aluminium. All impellers offer non-overloading characteristics and are dynamically balanced for maximum efficiency. The casing is manufactured in sheet steel with Doby flanges at both ends.

The full range of MFQ fans is manufactured with an Aluzinc casing suitable for both internal and external mounting as standard.

## Motors

A proven external rotor motor design and advanced new design of radial mixed flow impeller assembly has been specially selected for its performance and non-overloading characteristics. The assembly is dynamically balanced to VDI 2060. The motors in this range are rated at IP44 according to BS EN 60529. Ball bearings are greased for life and are designed to run at any angle. Insulation is Class B (from -30 °C to +40 °C).



## Electrical

Single phase 220-240V 50 Hz. Capacitor: start and run. Capacitors are located in the terminal box. Three phase 380-415V 50Hz. All motors are fitted with Standard Thermal Overload Protection (S.T.O.P.).

## Performance and Sound

Tested to ISO 5801. Published dB(A) figures are free field sound pressure levels at 3m with spherical propagation at a reference level of  $2 \times 10^{-5}$ Pa (20 micro-Pascal). The inlet, outlet and breakout sound power level spectra figures are dB with a reference of  $10^{-12}$  Watts (1 pico-watt).

## Quality Assurance

Design and manufacture is in accordance with BS EN ISO 9001:2015.

## Fan Dimensions (mm)

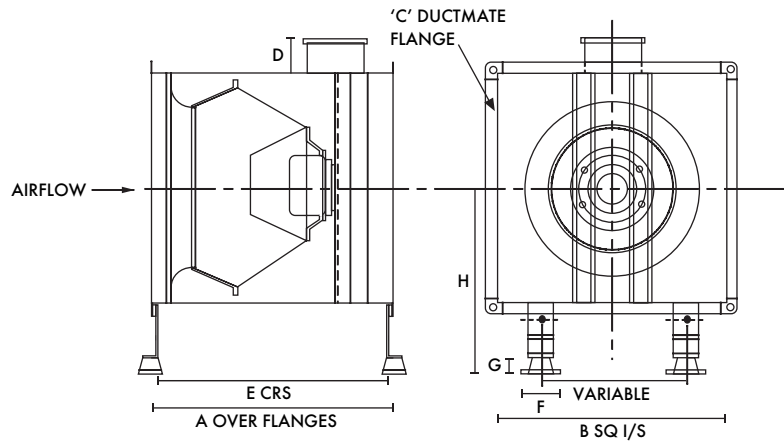

Unit	Duct Size	A	B	C	D	E	F	G	H	Weight kg
350	450 x 450	400	450	25	52	406	62	29	345	22
400	500 x 500	450	500	25	52	456	62	29	370	28
450	550 x 550	485	550	35	52	491	62	29	405	42
500	650 x 650	510	650	35	86	516	102	37	455	73
560	700 x 700	530	700	35	52	536	102	37	480	78

# Performance Guide

350 to 500 dia. - 1 Phase - 4 Pole

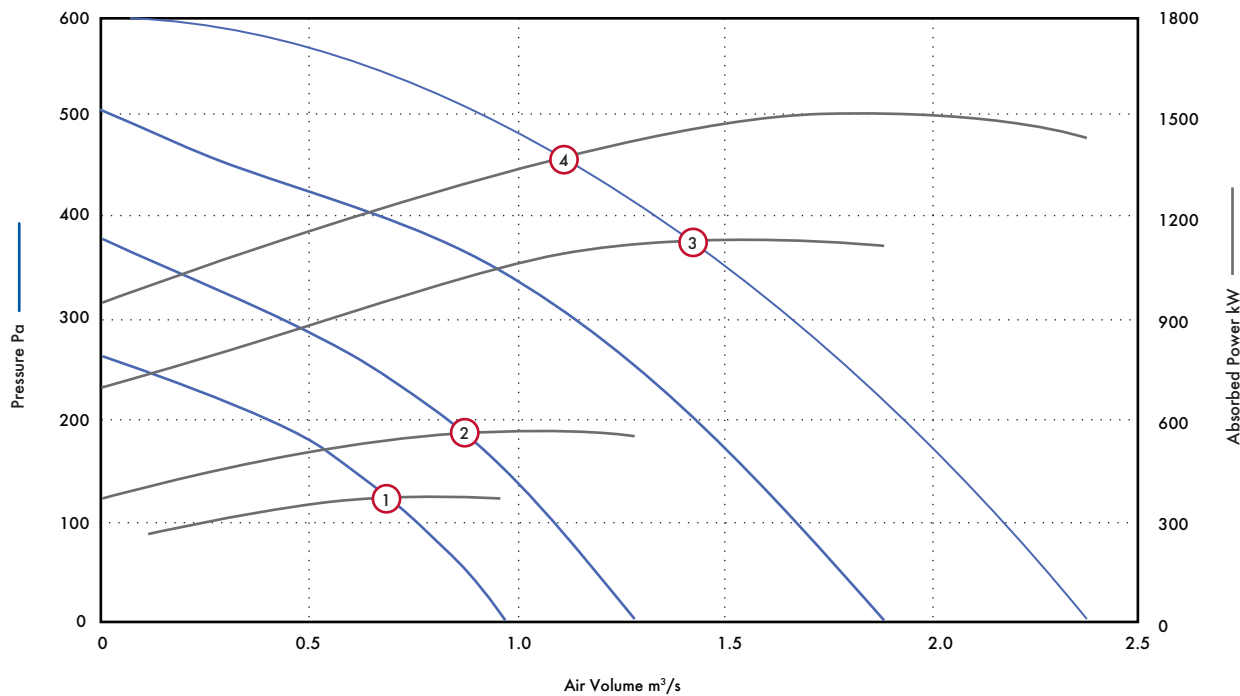

Motor Phase	Stock Ref	Poles	r.p.m	Curve Ref.	Duty m³/s @ Pa						Motor kW	S.C. Amps	F.L.C Amps	dBA @ 3m	
					0	100	200	300	400	500					
1	MFQ35014	4	1390	1	m³/s	0.97	0.80	0.56				0.37	5.5	1.85	55
					kW	368.63	377.76	356.75							
1	MFQ40014	4	1270	2	m³/s	1.29	1.08	0.83	0.44			0.58	6	2.6	57
					kW	556.85	572.65	558.43	490.72						
1	MFQ45014	4	1380	3	m³/s	1.89	1.67	1.44	1.15	0.70	0.05	1.1	17	5.2	59
					kW	1117.53	1135.29	1138.63	1105.84	968.60	720.78				
1	MFQ50014	4	1350	4	m³/s	2.38	2.17	1.94	1.66	1.34	0.92	1.65	22	7.4	61
					kW	1443.11	1494.90	1518.53	1506.19	1448.25	1327.76				

Max temperature 60°C

## Sound Power Level Spectra dB (re 10<sup>-12</sup> Watts)

Motor Phase	Stock Ref	Poles	Spectrum	63	125	250	500	1k	2k	4k	8k	dBA @ 3m
1	MFQ35014	4	Inlet	70	74	76	72	72	70	62	54	56
			Outlet	70	74	76	72	72	70	62	54	56
1	MFQ40014	4	Inlet	71	78	79	75	74	69	68	59	58
			Outlet	71	78	79	75	74	69	68	59	58
1	MFQ45014	4	Inlet	80	82	79	76	78	73	68	60	61
			Outlet	80	82	79	76	78	73	68	60	61
1	MFQ50014	4	Inlet	83	85	81	79	80	76	71	66	63
			Outlet	83	85	81	79	80	76	71	66	63

Performance Guide

400 to 560 dia. - 3 Phase - 4 & 6 Pole

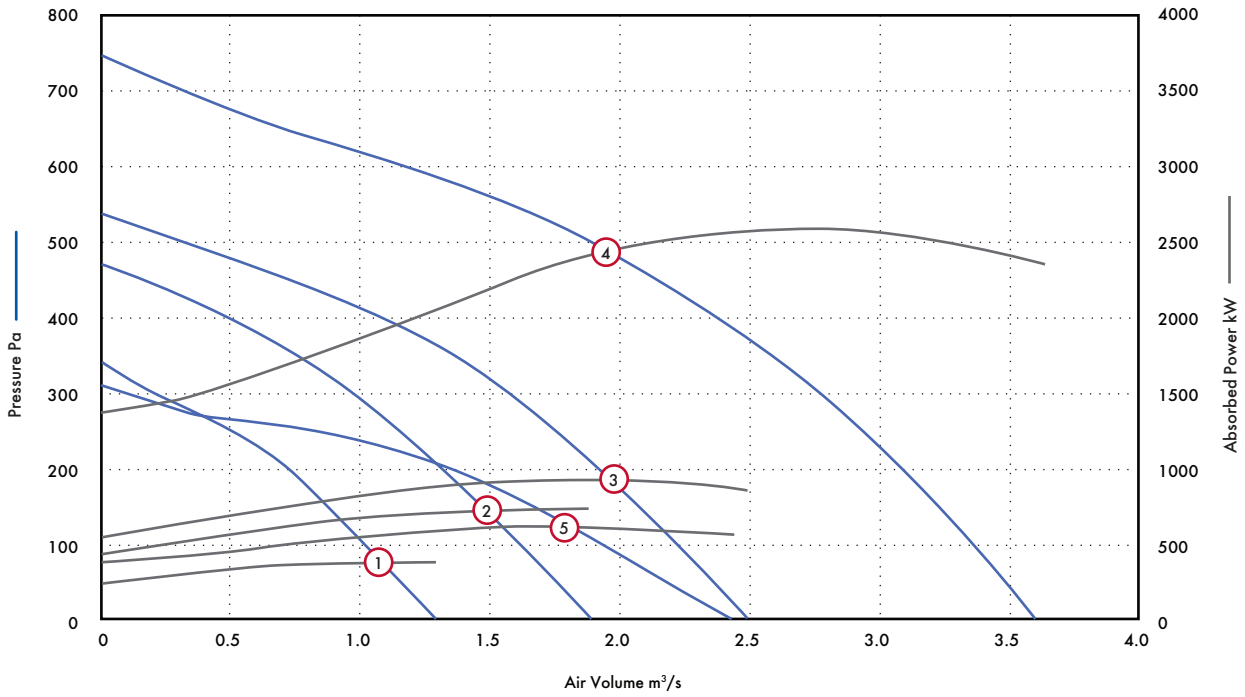

Motor Phase	Stock Ref	Poles	r.p.m	Curve Ref.	Air Volume m³/s								Motor kW	S.C. Amps	F.L.C Amps	dBA @ 3m		
					0	100	200	300	400	500	600	700						
3	MFQ40034	4	1290	1	m³/s	1.30	1.02	0.72	0.21						0.54	4.2	1.2	57
					kW	364.79	370.14	358.53	278.39									
3	MFQ45034	4	1370	2	m³/s	1.89	1.62	1.32	0.97	0.48				1	9.5	1.95	59	
					kW	726.01	726.43	709.22	663.41	558.26								
3	MFQ50034	4	1280	3	m³/s	2.49	2.22	1.93	1.57	1.09	0.31			1.45	9.5	2.8	61	
					kW	868.76	904.37	923.04	911.64	836.23	623.80							
3	MFQ56034	4	1330	4	m³/s	3.61	3.36	3.08	2.76	2.39	1.90	1.17	0.29	2.5	22	4.6	68	
					kW	2366.71	2470.94	2550.37	2590.56	2561.68	2404.60	1989.32	1464.97					
3	MFQ56036	6	920	5	m³/s	2.44	1.94	1.36	0.08					0.86	9	2.2	54	
					kW	567.82	603.77	597.59	387.12									

Sound Power Level Spectra dB (re 10<sup>-12</sup> Watts)

Motor Phase	Stock Ref	Poles	Spectrum	63	125	250	500	1k	2k	4k	8k	dBA @ 3m
3	MFQ40034	4	Inlet	71	78	79	75	74	69	68	59	58
			Outlet	71	78	79	75	74	69	68	59	58
3	MFQ45034	4	Inlet	80	82	79	76	78	73	68	60	61
			Outlet	80	82	79	76	78	73	68	60	61
3	MFQ50034	4	Inlet	83	85	81	79	80	76	71	66	63
			Outlet	83	85	81	79	80	76	71	66	63
3	MFQ56034	4	Inlet	86	90	87	86	87	81	74	69	69
			Outlet	86	90	87	86	87	81	74	69	69
3	MFQ56036	6	Inlet	76	75	73	73	73	65	57	49	55
			Outlet	76	75	73	73	73	65	57	49	55



## Accessories Dimensions (mm)

### Flexible Connectors and Silencer

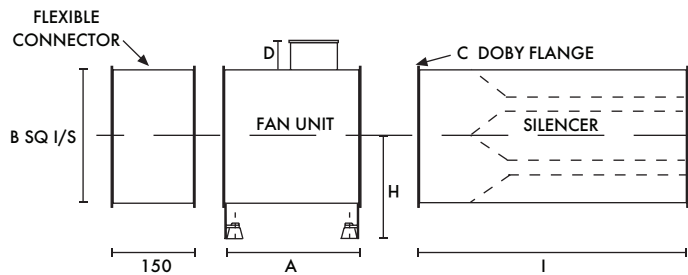

Unit	A	B	C	D	H	I	Weight Flange	
							kg	Doby
350	400	450	25	52	345	1200	45	30
400	450	500	25	52	370	1200	48	30
450	485	550	35	52	405	1200	55	30
500	510	650	35	86	455	1500	67	30
560	530	700	35	52	480	1500	70	30

### Mount/Feet Details

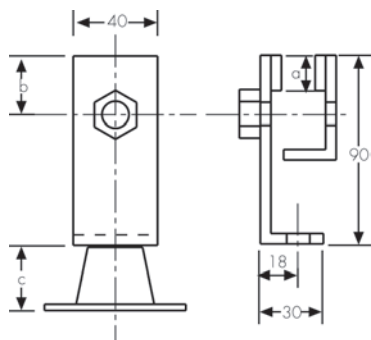

Stock Ref	a	b	c
PAVM 10	21	38	27
PAVM 20	21	38	27
PAVM 30	21	38	35

### Clamp Details

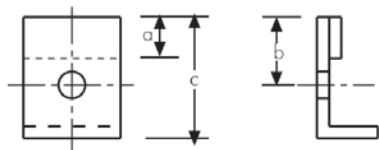

Stock Ref	a	b	c
PAVM 10	21	38	60
PAVM 20	21	38	60
PAVM 30	21	38	60

### Silencer Resistance Pa

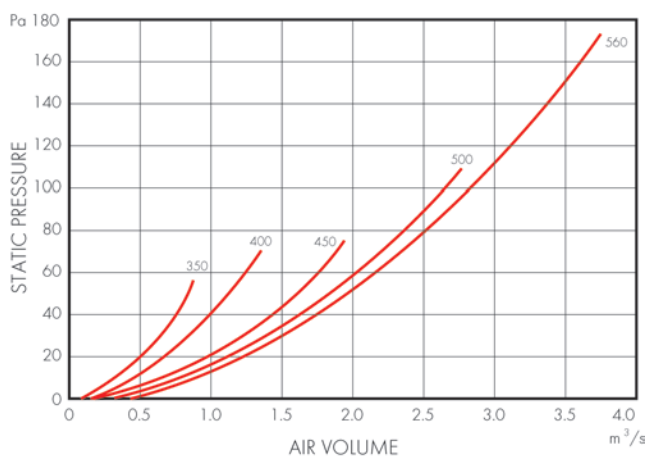

### Silencer Insertion Losses

Size	63	125	250	500	1k	2k	4k	8k
350	-3	-5	-14	-27	-36	-36	-29	-24
400	-2	-4	-12	-22	-30	-30	-22	-14
450	-2	-4	-11	-17	-24	-24	-16	-8
500	-3	-6	-15	-23	-31	-31	-21	-11
560	-4	-8	-16	-24	-32	-32	-22	-12

## Accessories

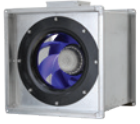

Standard Fan Stock Ref	Electronic Controller Stock Ref	Auto Transformer Stock Ref	D.O.L.		eDemand Controller	
			Starter Stock Ref	Overload Stock Ref	Voltage Control Stock Ref	3 Phase Inverter Stock Ref
MFQ35014	SC5030TK	10314103	444744	444700	444164	-
MFQ40014	SC5030TK	10314103	444744	444702	444164	-
MFQ40034*	-	10314301	444747	444700	444166	444172
MFQ45014	SC5060TK	10314107	444744	444703	444164	-
MFQ45034*	-	10314301	444747	444701	444166	444172
MFQ50014	SC5010TK	10314113	444744	444704	444165	-
MFQ50034*	-	10314304	444747	444702	444166	444173
MFQ56034	-	10314307	444747	444703	444166	444173
MFQ56036*	-	10314304	444747	444701	444166	444172

\*For full range of speed controller options, see Accessories & Controllers section

Size	Set of Mounting	Flexible	Matching	Acoustic
	Feet & AV's	Connection	Attenuator	Jacket
	Stock Ref	Stock Ref	Stock Ref	Stock Ref
350	PAVM10	MFQFC350	MFQSS350	MFQAJ350
400	PAVM10	MFQFC400	MFQSS400	MFQAJ400
450	PAVM10	MFQFC450	MFQSS450	MFQAJ450
500	PAVM20	MFQFC500	MFQSS500	MFQAJ500
560	PAVM20	MFQFC560	MFQSS560	MFQAJ560

# Twin Fan



Vent-Axia twin fan range encompasses direct driven models with air performance up to  $3.5\text{m}^3/\text{s}$  with circular duct from 100 to 500mm and rectangular ducts up to 1200x850mm.

As with many Vent-Axia units our Trackmaster twin fan controller range offers the end user flexibility when interfaced with a BMS.

In-line with our constant drive to offer energy efficient solutions the Slimpack EC range offers an EC motor driven twin fan with simple commissioning control to provide the performance required at the lowest power consumption.

**Vent-Axia**

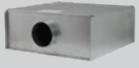

Sлимпак EC Twin Fan (SLPT EC)

L3-L8

---



Acoustic Twin Fans (ATQ)

L9-L14

---



Power-Line<sup>®</sup> (TDF)

L15-L18

---



Trakmaster Twin Fan Controller

L19-L20

---



# Slimpak EC Box Fan (SLPT EC)

- Compact low profile design
- Duct Sizes 100 - 500mm
- Performance - Airflow 0.01 to 1.2m<sup>3</sup>/s, Pressure up to 650Pa
- Latest energy saving EC/DC motors
- Internal mounting IPX2
- Manufactured controlled to BS EN ISO 9001:2015
- Performance tested to BS848 Part 1 & 2

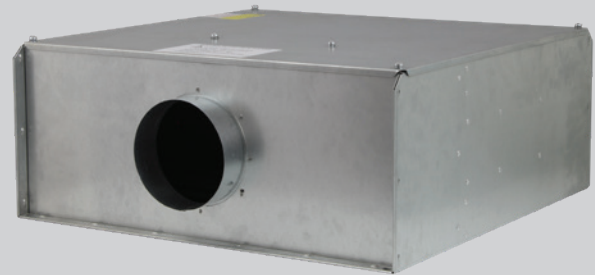

The range of Slimpak EC twin in-line duct fans incorporate energy efficient EC motors and basic commissioning controls to offer an energy efficient twin extract fan system.

Manufactured from prime quality galvanised sheet steel the Slimpak (SLPT EC) twin fan units are internally treated with an 'O' class rated, BS476 part 6 & 7, acoustic foam, which offers the benefits of high sound absorption, good thermal insulation properties in addition to self extinguishing properties and resistant to ignition.

The housing is designed to be as compact as possible for concealed false ceiling applications yet is suitable for ceiling or floor mounting, non-return dampers can be easily rotated on site to suit the application.

---

## Motor / Impellers

All SLPT EC units feature a low energy, Class 1, EC/DC external rotor motor and backward curved impeller assembly specifically chosen for performance and non-overloading characteristics. The assembly is dynamically balanced to DIN ISO 1940 Grade 6.3, duct size 500mm rated IP54, all other sizes, IP44 according to BS EN 60529. Ball bearings are greased for life. Insulation is Class 'B' (from -25°C to +60°C).

All models incorporate internal electronic overload protection and soft start function.

---

## Electrical

Every SLPT EC unit is fitted with a purpose designed common integral commissioning controller giving the ability to set the exact duty required at commissioning. Alternatively the integral potentiometer can be bypassed to allow remote speed control via an external 0-10V potentiometer. Low voltage wiring is kept separate from the mains wiring.

---

---

## Electrical

Motors are single phase 230V +/- 10% / 50/60Hz / 1ph (size 100-400mm) or 400V +/- 10% / 50/60Hz / 3ph (size 500mm), (4 wire systems only).

---

---

## Performance/Sound

Extensively tested to BS848 parts 1 & 2. Published dB(A) figures are free field sound pressure levels at 3m with spherical propagation at reference level of 2x10<sup>-5</sup> Pa. The inlet/outlet sound power level spectra figures are dB with a reference of 10-12 watts.

---

---

## Quality Assurance

Design and manufacture are in accordance with the standard for quality management systems BS EN ISO 9001:2015.

---

---

## Accessories

A full range of accessories are available with the Slimpak EC range of fans such as:

- Auto changeover controller designed for EC motors
  - Two speed trickle boost controller
  - Pre & secondary filter cassettes
  - Electric heater batteries
  - Backdraught shutters
  - In-line attenuators
-

Dimensions (mm)

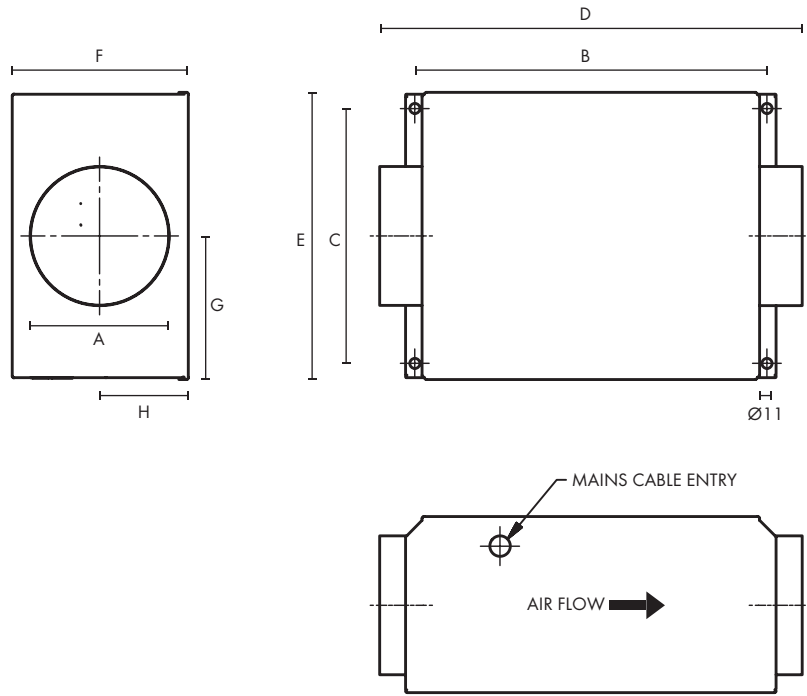

Stock Ref	A	B	C	D	E	F	G	H	kg
SLPT100EC	100	610	591	705	622	256	311	128	26
SLPT125EC	125	610	591	705	622	256	311	128	26
SLPT150EC	150	610	591	705	622	256	311	128	26
SLPT200EC	200	801	703	896	734	343	367	172	39
SLPT250EC	250	925	798	1020	829	354	415	177	48
SLPT315EC	315	1255	1145	1353	1176	536	588	268	88
SLPT400EC	400	1255	1145	1353	1176	536	588	268	90
SLPT500EC	500	1492	1533	1590	1564	675	782	338	175

## Performance Guide

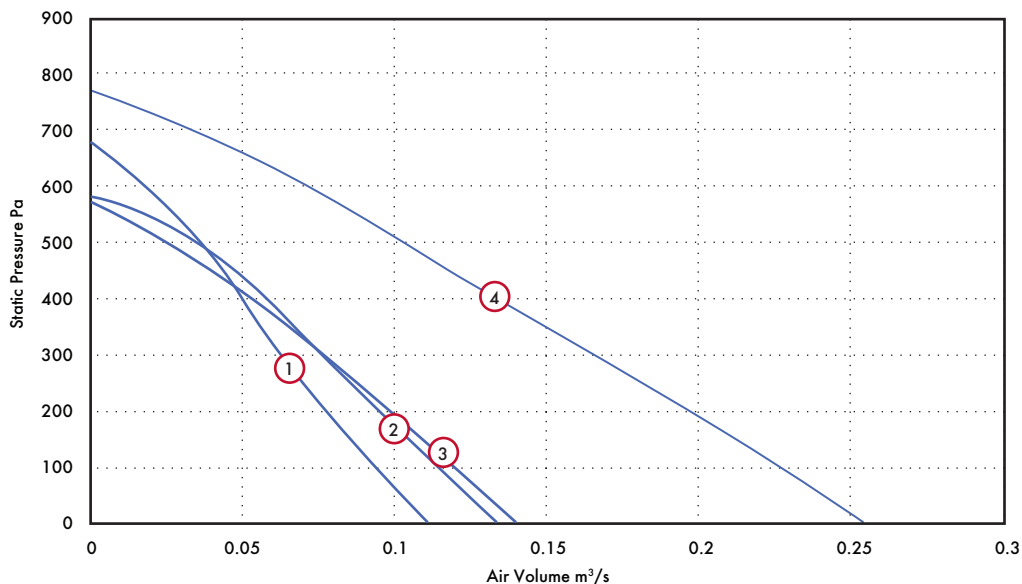

Dia.	Motor Phase	Stock Ref	IP Rating	Curve Ref.	m <sup>3</sup> /s @ Pa								S.C. Amps	F.L.C. Amps	dB(A) @ 3m	
					0	100	200	300	400	500	600	700				
100	1	SLPT100EC	IP44	1	m <sup>3</sup> /s	0.11	0.09	0.08	0.06	0.05	0.04	0.02	0.69	0.69	36	
					kW	0.08	0.08	0.08	0.08	0.08	0.08	0.08				
					W/l/s	0.74	0.89	1.09	1.34	1.70	2.35	4.40				
125	1	SLPT125EC	IP44	2	m <sup>3</sup> /s	0.13	0.11	0.09	0.08	0.06	0.03	0.72	0.72	39		
					kW	0.08	0.08	0.08	0.08	0.08	0.08					
					W/l/s	0.61	0.72	0.87	1.08	1.42	2.24					
150	1	SLPT150EC	IP44	3	m <sup>3</sup> /s	0.14	0.12	0.10	0.08	0.05	0.02	0.71	0.71	39		
					kW	0.08	0.08	0.08	0.08	0.08	0.08					
					W/l/s	0.58	0.70	0.84	1.07	1.54	3.09					
200	1	SLPT200EC	IP44	4	m <sup>3</sup> /s	0.25	0.23	0.20	0.17	0.13	0.10	0.07	0.04	1.4	1.4	42
					kW	0.16	0.17	0.17	0.17	0.17	0.17	0.17	0.16			
					W/l/s	0.63	0.72	0.84	1.01	1.26	1.64	2.34	4.37			

## Sound Power Level Spectra dB (ref 10<sup>-12</sup> Watts)

Dia.	Motor Phase	Stock Ref	Spectrum	63	125	250	500	1k	2k	4k	8k	dB(A) @ 3m
100	1	SLPT100EC	Inlet	55	63	56	53	49	45	38	34	35
			Outlet	53	65	59	58	54	55	48	39	40
			Breakout	65	69	61	50	42	40	37	36	36
125	1	SLPT125EC	Inlet	52	66	66	56	51	47	38	39	40
			Outlet	54	69	64	61	57	57	52	43	43
			Breakout	59	72	64	52	41	36	35	36	39
150	1	SLPT150EC	Inlet	58	66	66	59	50	46	39	36	40
			Outlet	60	71	67	64	61	61	55	49	47
			Breakout	60	63	62	59	51	47	42	41	39
200	1	SLPT200EC	Inlet	58	70	63	68	62	55	51	49	47
			Outlet	68	75	65	80	67	67	64	60	58
			Breakout	67	69	64	63	51	45	38	40	42

## Performance Guide

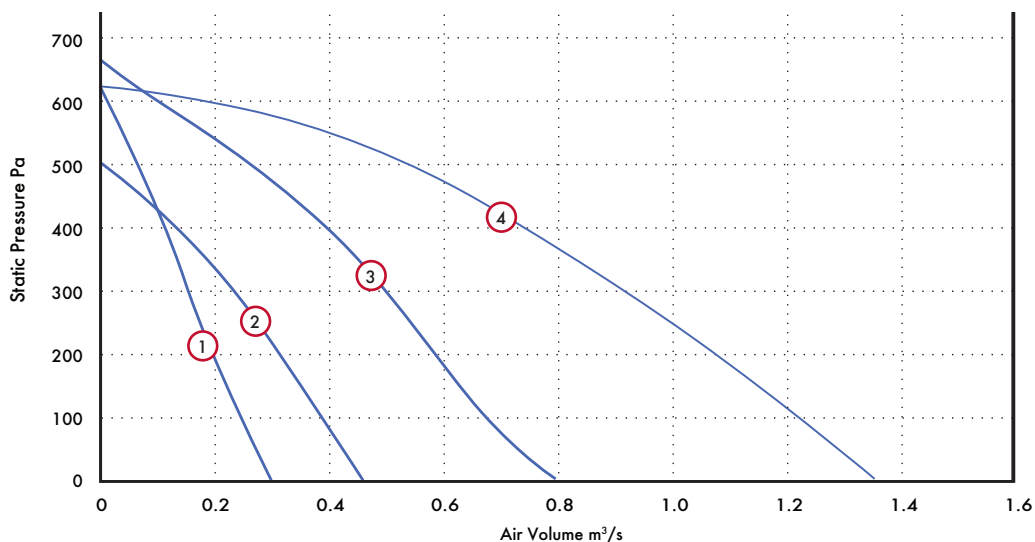

Dia.	Motor Phase	Stock Ref	IP Rating	Curve Ref.	m³/s @ Pa								S.C. Amps	F.L.C Amps	dB(A) @ 3m
					0	100	200	300	400	500	600				
250	1	SLPT250EC	IP44	1	m³/s	0.30	0.25	0.20	0.15	0.11	0.07	0.01	1.4	1.4	39
					kW	0.14	0.14	0.14	0.14	0.14	0.14	0.12			
					W/l/s	0.47	0.58	0.69	0.88	1.25	2.13	17.44			
315	1	SLPT315EC	IP44	2	m³/s	0.46	0.39	0.32	0.24	0.14			1.4	1.4	43
					kW	0.14	0.14	0.15	0.15	0.15					
					W/l/s	0.30	0.36	0.46	0.63	1.06					
400	1	SLPT400EC	IP44	3	m³/s	0.80	0.68	0.59	0.50	0.40	0.27	0.10	2.86	2.86	48
					kW	0.39	0.38	0.37	0.36	0.37	0.39	0.39			
					W/l/s	0.49	0.56	0.63	0.73	0.92	1.46	3.90			
500	3	SLPT500EC	IP54	4	m³/s	1.37	1.24	1.09	0.92	0.75	0.57	0.35	2.1	2.1	46
					kW	0.61	0.67	0.71	0.73	0.73	0.71	0.66			
					W/l/s	0.45	0.54	0.66	0.79	0.97	1.25	1.88			

## Sound Power Level Spectra dB (ref 10<sup>-12</sup> Watts)

Dia.	Motor Phase	Stock Ref	Spectrum	63	125	250	500	1k	2k	4k	8k	dB(A) @ 3m
250	1	SLPT250EC	Inlet	64	68	61	69	60	50	50	47	47
			Outlet	63	69	62	78	66	67	61	57	56
			Breakout	61	64	61	60	49	42	36	35	39
315	1	SLPT315EC	Inlet	63	74	65	59	52	46	43	40	42
			Outlet	66	76	68	69	63	61	53	45	49
			Breakout	66	72	71	51	44	38	36	32	43
400	1	SLPT400EC	Inlet	73	82	73	66	62	53	50	45	50
			Outlet	75	85	78	77	73	69	63	55	58
			Breakout	78	77	75	61	55	48	46	41	48
500	3	SLPT500EC	Inlet	88	93	86	80	71	67	59	53	62
			Outlet	87	91	89	84	83	78	68	62	67
			Breakout	74	80	76	67	61	54	44	36	50



## Models & Accessories



Fan Stock Ref	Trickle/Boost Controller Stock Ref	EC Fan Changeover Controller Stock Ref
SLPT100EC	475775	476367
SLPT125EC	475775	476367
SLPT150EC	475775	476367
SLPT200EC	475775	476367
SLPT250EC	475775	476367
SLPT315EC	475775	476367
SLPT400EC	475775	476367
SLPT500EC	475775	476367



Backdraught Shutter  
Stock Ref



Fast Clamp  
Stock Ref



Anti-Vibration Mounts (set of 4)  
Stock Ref

Size	Backdraught Shutter Stock Ref	Fast Clamp Stock Ref	Anti-Vibration Mounts (set of 4) Stock Ref
100	10542100	10540100	68MP033G
125	10542125	10540125	68MP033G
150	10542150	10540150	68MP033G
200	10542200	10540200	68MP033G
250	10542250	10540250	68MP033G
315	10542315	10540315	68MP033G
400	10542400	10540400	68MP033G
500	-	-	68MP033G



Duct Attenuator

Size	300mm Stock Ref	600mm Stock Ref	900mm Stock Ref	1200mm Stock Ref
100	10534100	10535100	10536100	-
125	10534125	10535125	10536125	-
150	10534150	10535150	10536150	-
200	-	10535200	10536200	10537200
250	-	10535250	10536250	10537250
315	-	10535315	10536315	10537315
400	-	10535400	10536400	10537400
500	-	-	10536500	-

## Models & Accessories



Size	Duct Air Heater Stock Ref	Filter Cassette Stock Ref	Bag Filter Cassette Stock Ref	Flexible Connections Stock Ref
100	10531100T1	10532100	10533100	FLX100
125	10531125T1	10532125	10533125	FLX125
150	10531150T1	10532150	10533150	FLX150
200	10531200T1	10532200	10533200	FLX200
250	10531250T1	10532250	10533250	FLX250
315	10531315T1 10531315T3	10532315	10533315	FLX315
400	10531400T3	10532400	10533400	FLX400
500	10531500T3	10532500A	10533500	FLX500

# Acoustic Twin Fans (ATQ)

- Improved efficiency available in sizes from 100 to 400mm dia.
- Acoustically treated housing, Class 'O' rated, now with sandwich construction for maximum noise absorption
- Now manufactured in Aluzinc for internal and external use
- Motor insulation Class B
- Maximum operating temperature 50°C
- Standard Thermal Overload Protection
- Manufacture controlled to BS EN ISO 9001:2015
- Performance tested to BS 848 Part 1 & 2
- 2 Year Guarantee



Vent-Axia ATQ fans feature an acoustic foam of dual density sandwich construction specially selected for maximum sound absorption and quiet operation. The housing is designed to be as compact as possible for concealed false ceiling applications. Manufactured in Aluzinc sheet metal, with integral anchorage points to allow the fan to be suspended horizontally via drop rods or anti vibration mounts, ensuring a quick and easy solution to installation. The access panel is easily removed for inspection. Individual gravity operated shutters prevent air from passing through the unit during shut down periods.

The full range of acoustic fans are manufactured from Aluzinc and as such are suitable for both internal and external mounting as standard.

Nine models are available in sizes 100, 125, 150, 160, 200, 250, 315 and 400, providing air volumes from 0.08m<sup>3</sup>/s to 1.27m<sup>3</sup>/s (288m<sup>3</sup>/h to 4572m<sup>3</sup>/h) at free air. Designed for pressures up to 550 Pa.

---

## Motors

At the heart of the range is a proven external rotor motor and high efficiency backward curved impeller specially selected for its performance. The assembly is dynamically balanced to ISO 1940. Motors are rated to IP44 according to BS EN 60529. Ball bearings are greased for life and allow the fan to run at any angle. Insulation is Class 'B' (from -15°C to +50°C).

All Acoustic fans are suitable for speed control, an Auto Transformer is recommended to ensure minimum noise levels during speed control so eliminating any possibility of motor harmonic noise.

Auto-changeover control is available from the Trackmaster range of controls providing auto changeover control on fan failure and duty sharing options. All controls provide BMS operation via volt free contacts and the option for remote indication.

For eDemand controls refer to Accessories & Controllers Section.

---

## Terminal Box

An IP54 Terminal Box is supplied with all models with 20mm cable gland entry.

---

## Performance and Sound

Tested to BS 848 Parts 1 & 2. Published dB(A) figures are free field sound pressure levels at 3m with spherical propagation at a reference level of 2 x 10<sup>-3</sup>Pa (20 micro-Pascal). The inlet, outlet and breakout sound power level spectra figures are dB with a reference of 10<sup>-12</sup> Watts (1 pico-watt).

---

## Electrical

The ATQ range is supplied with motors wound to suit a 230V/1ph/50Hz supply capacitor start and run.

---

## Quality Assurance

Design and manufacture is in accordance with BS EN ISO 9001:2015.

## Typical Installation

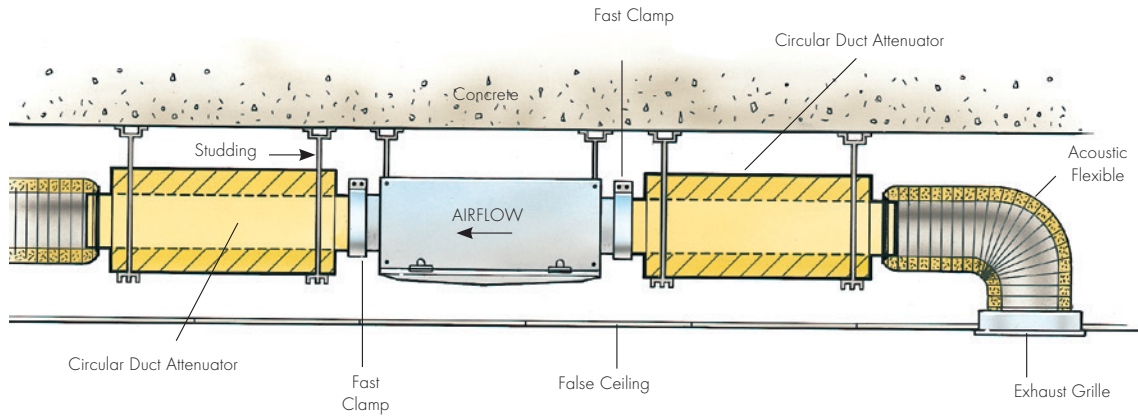

## Dimensions (mm)

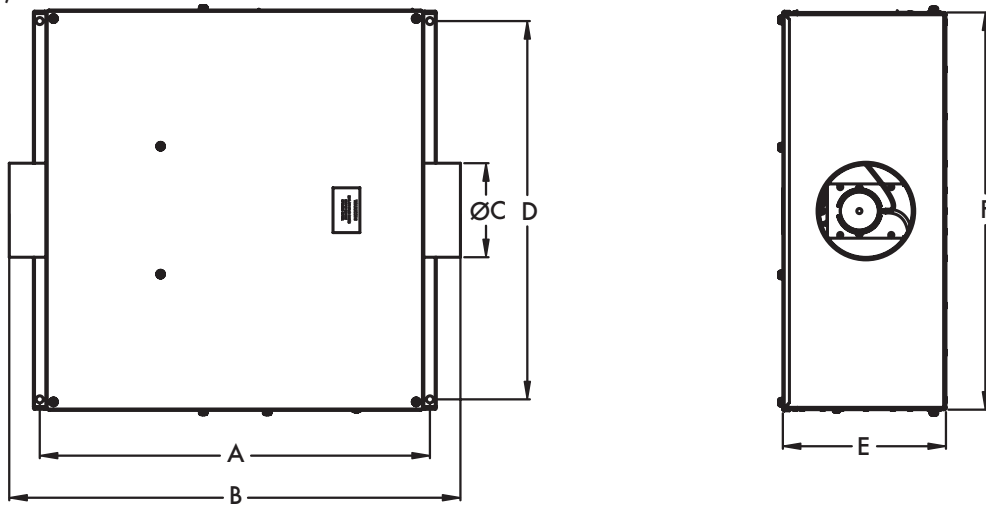

Stock Ref	Duct Diameter mm				Weight		
	A	B	ØC	D	E	F	kg
ATQ10012D	610	705	100	591	256	622	26
ATQ12512D	610	705	125	591	256	622	26
ATQ15012D	610	705	150	591	256	622	26
ATQ16012D	610	705	160	591	256	622	26
ATQ20012D	801	896	200	703	343	734	39
ATQ25012D	925	1020	250	798	354	829	48
ATQ31512LD	935	1035	315	846	426	892	88
ATQ31514HD	1255	1353	315	1145	536	1176	90
ATQ40014D	1255	1353	400	1145	536	1176	90

## Performance Curve

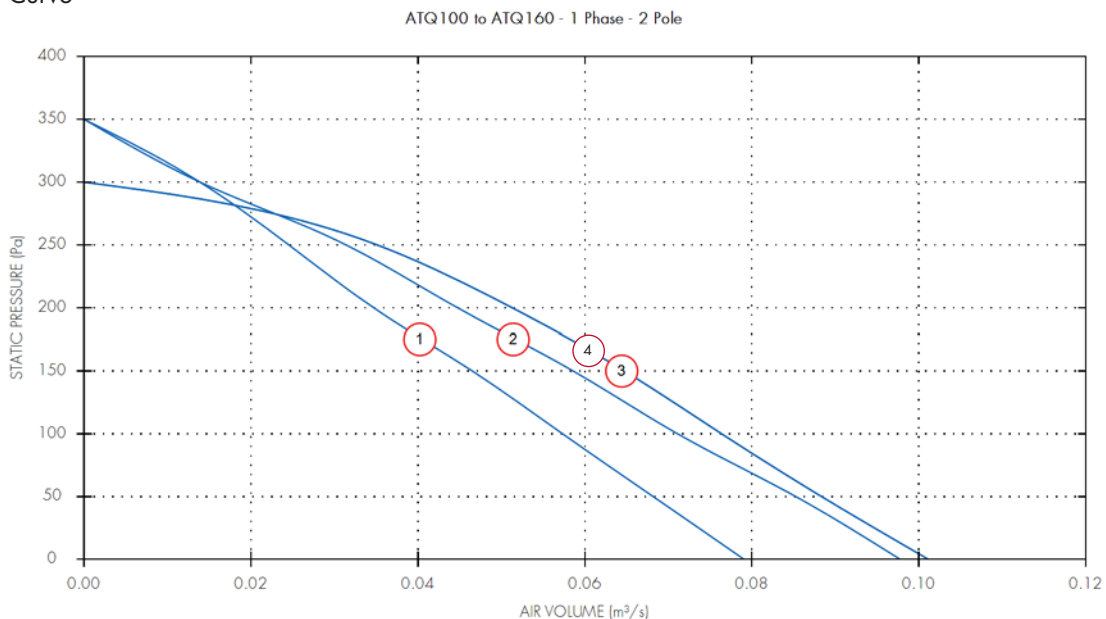

## Performance Guide

Airflow, m<sup>3</sup>/s @ Pa

Dia.	Motor Phase	Stock Ref	r.p.m	Curve Ref.	0	50	100	150	200	250	300	Motor kW	S.C. Amps	F.L.C Amps
100	1	ATQ10012D	2450	1	0.08	0.07	0.06	0.05	0.03	0.02	0.01	0.06	1.04	0.26
125	1	ATQ12512D	2450	2	0.1	0.09	0.07	0.06	0.04	0.03	0.01	0.06	1.04	0.26
150	1	ATQ15012D	2450	3	0.1	0.09	0.08	0.06	0.05	0.04		0.06	1.04	0.26
160	1	ATQ16012D	2450	4	0.1	0.09	0.08	0.06	0.05	0.04		0.06	1.04	0.26

## Sound Power Level Spectra dB (re 10<sup>-12</sup> Watts)

Dia.	Stock Ref	Spectrum	63	125	250	500	1k	2k	4k	8k	dBA @ 3m
100	ATQ10012D	Inlet	53	59	68	58	50	45	34	33	41
100	ATQ10012D	Outlet	54	57	63	59	60	54	49	42	43
100	ATQ10012D	Breakout	46	51	58	48	41	38	31	32	31
125	ATQ12512D	Inlet	51	65	73	62	51	46	36	36	45
125	ATQ12512D	Outlet	52	62	67	64	62	55	52	45	46
125	ATQ12512D	Breakout	48	52	59	49	41	40	33	32	32
150	ATQ15012D	Inlet	54	60	70	59	52	46	38	36	42
150	ATQ15012D	Outlet	56	58	63	58	59	56	49	43	43
150	ATQ15012D	Breakout	48	52	58	51	43	38	31	33	32
160	ATQ16012D	Inlet	54	60	70	59	52	46	38	36	42
160	ATQ16012D	Outlet	56	58	63	58	59	56	49	43	43
160	ATQ16012D	Breakout	48	52	58	51	43	38	31	33	32

# Performance Curve

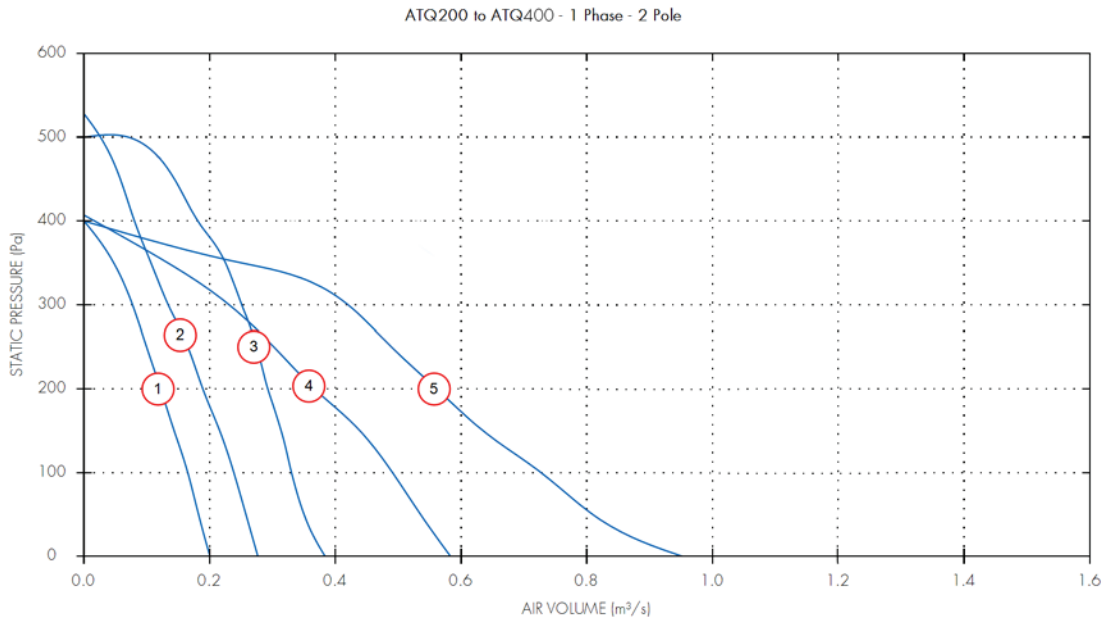

## Performance Guide

Dia.	Motor Phase	Stock Ref	r.p.m	Curve Ref.	Airflow, m³/s @ Pa										Motor kW	S.C. Amps	F.L.C Amps
					0	50	100	150	200	250	300	350	400	450			
200	1	ATQ20012D	2700	1	0.2	0.18	0.17	0.14	0.12	0.1	0.08	0.05			0.12	1.92	0.48
250	1	ATQ25012D	2400	2	0.28	0.26	0.24	0.22	0.19	0.17	0.13	0.11	0.08	0.06	0.13	3	0.65
315	1	ATQ31512LD	2550	3	0.38	0.35	0.33	0.31	0.29	0.27	0.25	0.23	0.18	0.14	0.23	5	1.02
315	1	ATQ31514HD	1330	4	0.58	0.54	0.49	0.44	0.37	0.3	0.23	0.13	0.02		0.27	4.72	1.18
400	1	ATQ40014D	1340	5	0.95	0.81	0.73	0.64	0.56	0.49	0.42	0.25			0.47	9.32	2.33

## Sound Power Level Spectra dB (re 10<sup>-12</sup> Watts)

Dia.	Stock Ref	Spectrum	63	125	250	500	1k	2k	4k	8k	dBa @ 3m
200	ATQ20012D	Inlet	60	65	63	68	58	55	54	46	46
200	ATQ20012D	Outlet	60	63	68	72	68	67	62	53	53
200	ATQ20012D	Breakout	53	58	57	55	46	41	35	34	34
250	ATQ25012D	Inlet	64	74	72	67	57	55	56	53	48
250	ATQ25012D	Outlet	64	74	75	69	70	71	65	64	56
250	ATQ25012D	Breakout	52	57	68	52	44	40	36	38	39
315	ATQ31512LD	Inlet	72	69	79	67	63	62	60	61	52
315	ATQ31512LD	Outlet	69	68	74	70	70	71	66	70	56
315	ATQ31512LD	Breakout	60	61	67	56	55	51	44	42	41
315	ATQ31514HD	Inlet	66	78	68	60	52	49	42	40	45
315	ATQ31514HD	Outlet	67	75	77	71	69	62	56	49	53
315	ATQ31514HD	Breakout	53	67	61	52	47	41	34	33	36
400	ATQ40014D	Inlet	73	82	79	68	62	55	50	49	52
400	ATQ40014D	Outlet	72	78	78	75	74	66	58	53	57
400	ATQ40014D	Breakout	57	68	61	56	51	45	39	34	38

### Duct Attenuators Dimensions (mm)

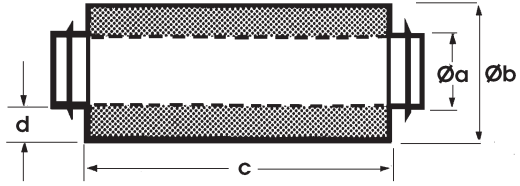

Stock						kg
Length	Ref.	Øa	Øb	c	d	approx
300	10534100	100	200	300	50	2.6
300	10534125	125	225	300	50	3.6
300	10534150	150	250	300	50	4
300	10534160	160	250	300	50	4
600	10535100	100	200	600	50	4
600	10535125	125	225	600	50	4.5
600	10535150	150	250	600	50	6
600	10535160	160	250	600	50	6
600	10535200	200	315	600	57.5	7.4
600	10535250	250	355	600	52.5	10.2
600	10535315	315	450	600	67.5	13
600	10535400	400	606	600	103	18.5
900	10536100	100	200	900	50	7
900	10536125	125	225	900	50	8
900	10536150	150	250	900	50	9
900	10536160	160	250	900	50	9
900	10536200	200	315	900	57.5	11
900	10536250	250	355	900	52.5	14.7
900	10536315	315	450	900	67.5	18
900	10536400	400	606	900	103	38
1200	10537200	200	315	1200	57.5	14
1200	10537250	250	355	1200	52.5	18.5
1200	10537315	315	450	1200	67.5	21.5
1200	10537400	400	606	1200	103	50

### Duct Attenuator Insertion Losses

Stock Ref.	Length	Duct Ø	Insertion Losses (dB)							
			63	125	250	500	1k	2k	4k	8k
10534100	300	100	3	4	10	18	23	25	25	12
10534125	300	125	3	4	8	17	21	23	21	11
10534150	300	150	3	3	6	14	20	23	21	11
10534160	300	160	3	3	6	14	20	23	21	11
10535100	600	100	5	8	16	33	39	40	36	17
10535125	600	125	4	8	13	30	34	35	31	15
10535150	600	150	4	7	13	23	29	36	31	15
10535160	600	160	4	7	13	23	29	36	31	20
10535200	600	200	4	5	11	21	26	32	20	9
10535250	600	250	3	6	10	19	24	29	19	8
10535315	600	315	3	5	8	16	21	22	16	15
10535400	600	400	3	4	7	14	18	19	14	13
10536100	900	100	10	13	20	39	45	38	35	18
10536125	900	125	9	12	18	37	41	37	32	16
10536150	900	150	8	9	15	30	37	37	33	17
10536160	900	160	8	9	15	30	37	37	33	17
10536200	900	200	7	9	14	27	31	36	25	12
10536250	900	250	5	8	13	24	30	31	22	11
10536315	900	315	4	7	11	20	31	27	17	12
10536400	900	400	3	5	9	19	26	20	13	11
10537200	1200	200	10	12	17	35	40	43	27	13
10537250	1200	250	7	9	15	31	36	38	26	12
10537315	1200	315	6	8	13	23	32	30	18	11
10537400	1200	400	6	8	14	24	30	28	17	9

Accessories



\*\*ITC-DS 12/24hr

Size	Standard Fan Stock Ref.	Auto Changeover Controller Stock Ref.
100	ATQ10012D	10314210
125	ATQ12512D	10314210
150	ATQ15012D	10314210
160	ATQ16012D	10314210
200	ATQ20012D	10314210
250	ATQ25012D	10314210
315	ATQ31512LD	10314210
315	ATQ31514HD	10314210
400	ATQ40014D	10314210

\*\*Not suitable for use with eDemand controllers. For compatible changeover panel, see Accessories and Controllers Section



Size	eDemand Auto Changeover Controller Stock Ref.	eDemand Voltage Controller Stock Ref.	*Anti-Vibration Mounts Stock Ref.	RVC Remote Visual Indicator Stock Ref.	Auto Transformer Stock Ref.
100	444180	444164	68MP033G	10314220	10314103
125	444180	444164	68MP033G	10314220	10314103
150	444180	444164	68MP033G	10314220	10314103
160	444180	444164	68MP033G	10314220	10314103
200	444180	444164	68MP033G	10314220	10314103
250	444180	444164	68MP033G	10314220	10314103
315	444180	444164	68MP033G	10314220	10314103
400	444180	444164	68MP033G	10314220	10314105

\*Set of 4



Size	Backdraught Shutter Stock Ref.	Fast Clamp Stock Ref.	Duct Attenuator			
	Stock Ref.	Stock Ref.	300mm Stock Ref.	600mm Stock Ref.	900mm Stock Ref.	1200mm Stock Ref.
100	10542100	10540100	10534100	10535100	10536100	-
125	10542125	10540125	10534125	10535125	10536125	-
150	10542150	10540150	10534150	10535150	10536150	-
160	-	10540160	-	10535160	-	-
200	10542200	10540200	-	10535200	10536200	10537200
250	10542250	10540250	-	10535250	10536250	10537250
315	10542315	10540315	-	10535315	10536315	10537315
400	10542400	10540400	-	10535400	10536400	10537400



# Power-Line (TDF)

- Direct Drive Twin Fan (Run & standby)
- Backward Curved Radial Impellers
- Performance range up to 3.5m<sup>3</sup>/s
- Static Pressure Development up to 500Pa
- Speed Controllable
- Quality assured to BS EN ISO 9001:2015
- Performance listed to BS 848 Part 1



The TDF range uses twin backward curved radial impellers (Run & Standby) and is designed for induct installations.

---

## Casings

Robustly constructed from aluzinc sheet steel, fitted with proprietary flanges at each end in accordance with DW142.

---

## Impellers

Aerodynamically designed backward curved radial impeller constructed in a moulded GRP reinforced Polypropylene to suit the performance requirements.

The rotor of the external rotor motor forms the hub of the impeller. Rotors and impellers are factory matched and statically and dynamically balanced on precision machines according to VDI2060 quality class Q6.3.

---

## Motors

Maintenance free external rotor motors with generously dimensioned sealed for life ball bearings encapsulating a high temperature lubricant. The bearings allow for the fan to be mounted at any angle.

Insulation is Class B with the enclosure IP44 according to DIN 40050. The electrical design corresponds to VDE 0530/12.84. The motors are suitable for operation in atmosphere up to 95% RH and ambients up to 40°C.

Motors are wound to suit either 240V 50HZ 1PH or 415V 50HZ 3PH electrical supply. All motors are fitted with Hot Spot protection by means of a thermal contact switch incorporated in the motor windings to prevent motor damage due to overloading. As the motors have a special torque-speed characteristic they are ideally suited for speed control by voltage reduction.

---

## Performance

Performance figures given have been tested using installation Type 'D' in accordance with BS848 Part 1 1980 and BS848 Part 2 1985. The aerodynamic performance data being to tolerance Class 'C' as recommended by BSI C.A.M.E Scheme, Certification No CM005.

---

## Sound Levels

Sound Levels are measured in a reverberant chamber in accordance with BS848 Part 2. Sound level measurements are taken with the fan operating at 20% of its maximum pressure development.

Published dBA figures are sound pressure levels measured at a distance of 3m with spherical sound level propagation. It is included for comparative purposes only and the real sound level experienced will depend on the acoustic characteristics of the area being served.

---

## Quality Assurance

Design and manufacture is in accordance with Quality Assured to BS EN ISO 9001:2015.

---

## Fan Dimensions (mm)

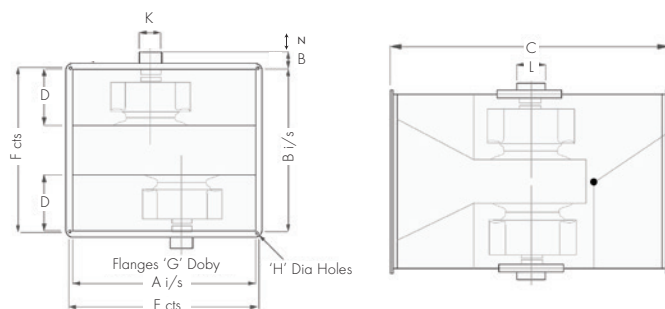

Unit Size	A	B	C	D	E	F	G	H	J	K	L	N	Max Weight kg
320	500	655	900	230	525	680	30	9	50	150	130	220	65
380	550	745	1015	260	585	780	30	11	50	160	130	240	75
420	625	830	1130	295	600	865	30	11	50	230	230	220	103
480	700	925	1250	325	735	960	30	11	65	230	230	300	112
520	775	1055	1385	355	810	1090	30	11	50	230	230	350	145
600	850	1200	1530	400	885	1235	30	11	55	230	230	400	180

Note: For motor removal allow D+J minimum clearance

## Power Line TDF Flexible Connections

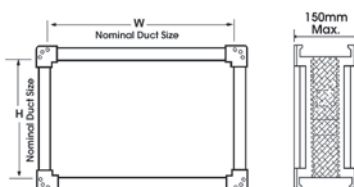

Dimensions (mm)

Unit Code	W	H	Doby Flange
320	500	655	30
380	550	745	30
420	625	830	30
480	700	925	30
520	775	1055	30
600	850	1200	30

## Power Line TDF Attenuators

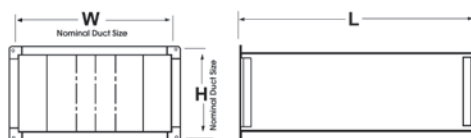

Unit Code	RUTDS	W	L	H	Doby	Weight kg
320		500	900	655	30	30
380		550	1200	745	30	62
420		625	1200	830	30	70
480		700	1500	925	30	96
520		775	1500	1055	30	110
600		850	1800	1200	30	150

## Performance Curve

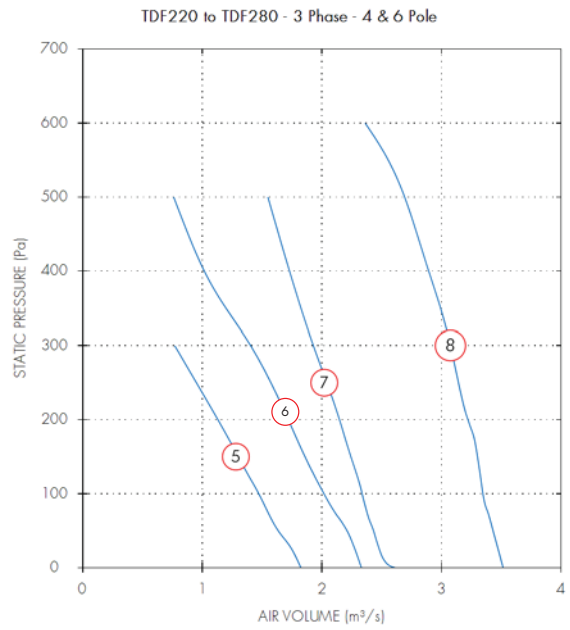
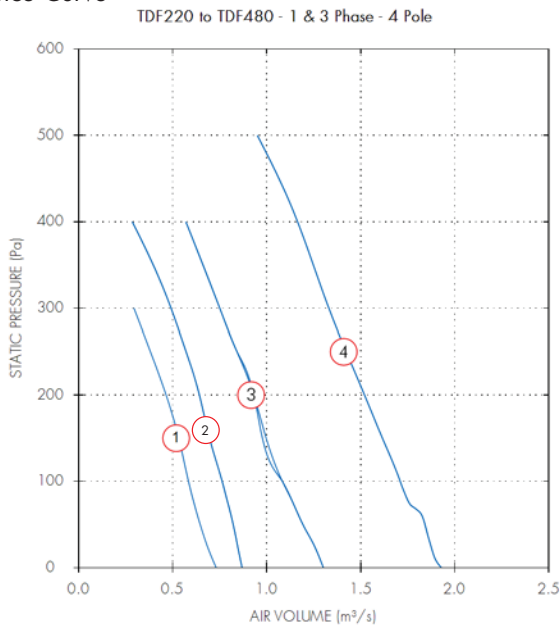

## Performance Guide

Unit Size	Motor		r.p.m	Curve Ref.	Airflow, m <sup>3</sup> /s @ Pa						Motor kW	S.C. Amps	F.LC Amps	dBA @ 3m	
	Phase	Stock Ref			0	100	200	300	400	500					600
320	1	TDF32014	1390	1	0.73	0.58	0.46	0.29				0.37	5.5	1.85	58
380	1	TDF38014	1270	2	0.87	0.76	0.64	0.49	0.28			0.58	6	2.6	59
380	3	TDF38034	1290	2	0.87	0.76	0.64	0.49	0.28			0.54	4.2	1.2	59
420	1	TDF42014	1380	3	1.3	1.08	0.93	0.75	0.57			1.1	17	5.2	61
420	3	TDF42034	1370	3	1.3	1.08	0.93	0.75	0.57			1	9.5	1.95	61
480	1	TDF48014	1350	4	1.93	1.71	1.52	1.33	1.16	0.95		1.65	22	7.4	66
480	3	TDF48034	1280	4	1.93	1.71	1.52	1.33	1.16	0.95		1.45	9.5	2.8	66
520	3	TDF52034	1330	6	2.61	2.34	2.15	1.93	1.73	1.55		2.5	22	4.6	67
520	3	TDF52036	920	5	1.82	1.47	1.13	0.77				0.86	9	2.2	55
600	3	TDF60034	1425	8	3.52	3.35	3.22	3.07	2.89	2.69	2.36	3.9	26	6.6	70
600	3	TDF60036	925	7	2.33	2.02	1.72	1.4	1.02	0.76		1.2	17	2.7	56

## Sound Power Level Spectra dB (re 10<sup>-12</sup> Watts)

Unit Size	Stock Ref	Spectrum	63	125	250	500	1k	2k	4k	8k	dBA @ 3m
320	TDF32014	Inlet	65	84	79	77	73	70	65	58	58
320	TDF32014	Outlet	65	84	79	77	73	70	65	58	58
320	TDF32014	Breakout	65	69	64	62	58	55	50	43	43
380	TDF38014	Inlet	66	84	78	79	75	71	66	59	60
380	TDF38014	Outlet	66	84	78	79	75	71	66	59	60
380	TDF38014	Breakout	66	69	63	64	60	56	51	44	45
380	TDF38034	Inlet	66	84	78	79	75	71	66	59	60
380	TDF38034	Outlet	66	84	78	79	75	71	66	59	60
380	TDF38034	Breakout	66	69	63	64	60	56	51	44	45
420	TDF42014	Inlet	74	91	83	81	76	72	69	65	62
420	TDF42014	Outlet	74	91	83	81	76	72	69	65	62
420	TDF42014	Breakout	74	76	68	66	61	57	54	50	47
420	TDF42034	Inlet	74	91	83	81	76	72	69	65	62
420	TDF42034	Outlet	74	91	83	81	76	72	69	65	62
420	TDF42034	Breakout	74	76	68	66	61	57	54	50	47
480	TDF48014	Inlet	76	95	88	86	81	76	76	71	67
480	TDF48014	Outlet	76	95	88	86	81	76	76	71	67
480	TDF48014	Breakout	76	80	73	71	66	61	61	56	52
480	TDF48034	Inlet	76	95	88	86	81	76	76	71	67
480	TDF48034	Outlet	76	95	88	86	81	76	76	71	67
480	TDF48034	Breakout	76	80	73	71	66	61	61	56	52
520	TDF52034	Inlet	80	96	89	86	83	78	72	66	68
520	TDF52034	Outlet	80	96	89	86	83	78	72	66	68
520	TDF52034	Breakout	80	81	74	71	68	63	57	51	53
520	TDF52036	Inlet	80	81	78	80	71	62	60	52	58
520	TDF52036	Outlet	80	81	78	80	71	62	60	52	58
520	TDF52036	Breakout	80	66	63	65	56	47	45	37	44
600	TDF60034	Inlet	83	99	94	90	87	85	75	70	72
600	TDF60034	Outlet	83	99	94	90	87	85	75	70	72
600	TDF60034	Breakout	83	84	79	75	72	70	60	55	57
600	TDF60036	Inlet	84	86	80	77	73	66	61	56	58
600	TDF60036	Outlet	84	86	80	77	73	66	61	56	58
600	TDF60036	Breakout	84	71	65	62	58	51	46	41	44

## Power-Line Silencers Type TDS

Unit Code TDS	Attenuation across Sound Spectrum H <sub>3</sub>							
	63	125	250	500	1K	2K	4K	8K
320	3	8	17	24	32	32	25	20
380	6	12	23	32	45	45	33	28
420	6	10	20	31	43	43	33	27
480	4	9	17	27	36	36	24	13
520	3	7	14	22	27	21	15	10
600	4	8	15	24	30	26	14	8

## Accessories



Size W x H	Fan Stock Ref.	Transformer Speed Controller Stock Ref.	*eDemand Controller		
			Auto Changeover Stock Ref.	Voltage Control Stock Ref.	3 Phase Inverter Stock Ref.
500 x 655	TDF32014	10314103	444180	444164	-
550 x 745	TDF38014	10314103	444180	444164	-
550 x 745	TDF38034	10314301	444179	444166	444172
625 x 830	TDF42014	10314105	444180	444164	-
625 x 830	TDF42034	10314304	444179	444166	444172
700 x 925	TDF48014	10314113	444180	444165	-
700 x 925	TDF48034	10314304	444179	444166	444173
775 x 1055	TDF52034	10314304	444179	444166	444173
775 x 1055	TDF52036	10314304	444179	444166	444172
850 x 1200	TDF60034	10314311	444179	444167	444175
850 x 1200	TDF60036	10314304	444179	444166	444173



Size W x H	**ITC-DS 12/24hr Auto Ch'over Stock Ref.	RVC Remote Visual Indicator Stock Ref.	Weather Proof Treatment Stock Ref.
	500 x 655	10314210	10314220
550 x 745	10314210	10314220	ECP2
625 x 830	10314210	10314220	ECP3
700 x 925	10314210	10314220	ECP3
775 x 1055	10314210	10314220	ECP3
850 x 1200	10314210	10314220	ECP4

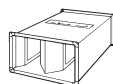
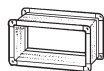

Size W x H	Mounting Feet & AVs (Set of 4) Stock Ref.	Flexible Connection Stock Ref.	Matching Attenuator Stock Ref.	Acoustic Jacket Stock Ref.	Discharge Cowl Stock Ref.	Roof Canopy Stock Ref.
	500 x 655	PAVM10	TFC320	RUTDS320	TAJ320	-
550 x 745	PAVM10	TFC380	RUTDS380	TAJ380	TDW380	TRC380
625 x 830	PAVM20	TFC420	RUTDS420	TAJ420	TDW420	TRC420
700 x 925	PAVM20	TFC480	RUTDS480	TAJ480	TDW480	TRC480
775 x 1055	PAVM30	TFC520	RUTDS520	TAJ520	TDW520	TRC520
850 x 1200	PAVM30	TFC600	RUTDS600	TAJ600	TDW600	TRC600

\*\*Not suitable for use with eDemand controllers. For compatible changeover panel, see Accessories and Controllers Section.

# Trakmaster Twin Fan Controller

- Range of intelligent Vent-Axia twin fan controllers
- For use with AC motors only
- Designed to offer total flexibility
- Controlled interface with BMS (Building Management Systems) saving installation costs
- Providing energy management/night setback facility

## ITC-DS - (Trakmaster twin fan control - Duty sharing)\*

Incorporates a timing mechanism which operates alternate fans on 12 or 24 hour intervals, thus ensuring the extended life of the fan bearings. The controller also provides automatic changeover on fan failure along with the facility for manual selection of either fan. (BMS compatible via volt free contacts). This controller must have a permanent live supply. Any On/Off switching must be via the sensor connections S1 and SG terminals.

Stock Ref  
10314210



## Electrical ITC-D S

Maximum load: 9 amps on single or three phase. Not for use with EC motors.

## Dimensions

ITC-DS - 103 14 210

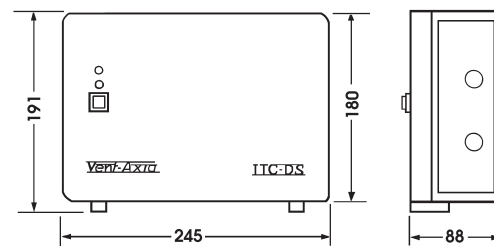

## RVC - (Remote visual indicator)

Wired in conjunction with either an ITC or ITC-DS controller the RVC can be located up to 100m away using low cost ELV wiring. The compact, single gang RVC ELV (Extra Low Voltage) remote visual controller indicates status of Fan 1 and Fan 2 with status/warning lights. Push button allows Fan 1 and Fan 2 with standby (Off) to be selected.

Stock Ref  
10314220



RVC - 10314220

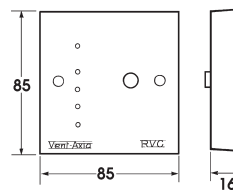

Note: Suitable for mounting with single gang electrical box.

\*For alternative eDemand twin fan controls see Accessories & Controllers Section

Sensors for use with ITC-DS controls

**ThermoSwitch**

Operates on either a fall or rise in temperature for extraction of excess heat. Range 6°C to 30°C.

Stock Ref.  
563502B



**HumidiSwitch**

Actuates mechanical humidistat ventilating units on either a rise or fall in humidity. Concealed adjustment. Range 20% to 80% RH.

Stock Ref.  
563501



**7-Day TimeSwitch**

7-Day timer with analogue display. Override facility. Gives twelve On or Off positions per day.

Stock Ref.  
563515A



**Air Quality Sensor**

Automatically reacts to tobacco smoke, smells and toilet odours to trigger the system or switch speed.

Stock Ref.  
563506



**Ecotronic Humidistat**

An electronic On/Off humidistat with concealed humidity adjustment 65-90% RH with removable pullcord override. Changeover relay switch.

Stock Ref.  
563550A



**Visionex PIR Detector**

Ceiling mounted movement detector. Adjustable overrun timer 5 to 25 minutes. Fits any UK single gang mounting box. Range of detection up to 10 metres. 220-240V.

Stock Ref.  
459623B



Connection Layout of ITC-DS Controller

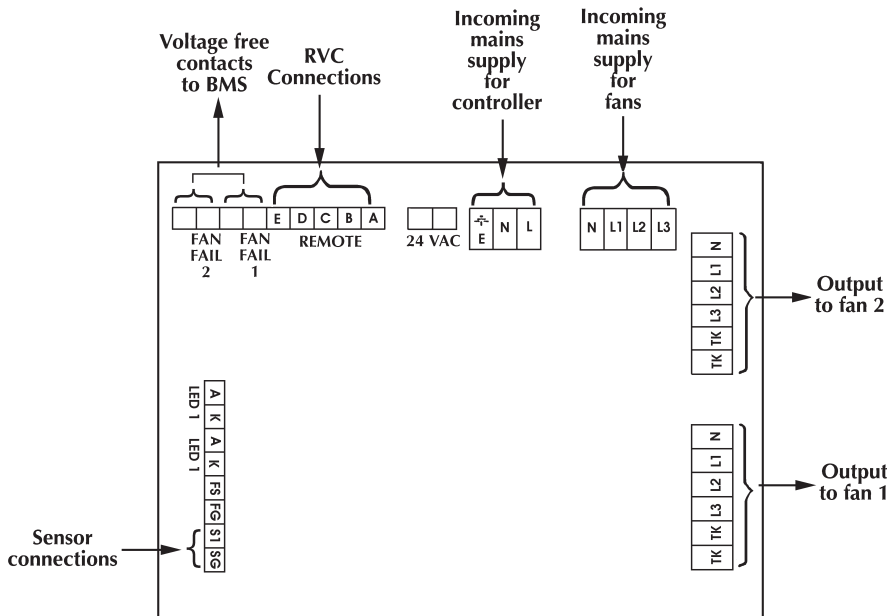

For full wiring information, refer to ITC Fitting & Wiring instructions.

PLEASE NOTE: The ITC Controllers may be used in conjunction with a 5-Step Auto Transformer speed controller for commissioning purposes to meet the required design criteria.



# Sentinel D-Box

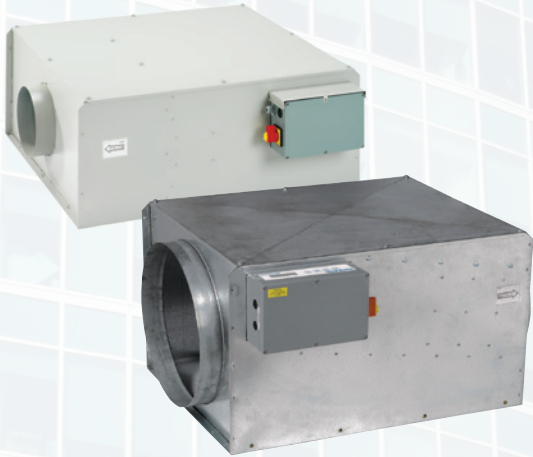

The Sentinel D-Box from Vent-Axia is the answer to key problems such as 'Why ventilate a room you're not using?' or 'Why over ventilate a room with only one or two occupants inside?'

Sentinel overcomes many of the issues encountered with a traditional fixed volume ventilation system that is either On or Off irrespective of the number of people in the room, risking room over ventilation, burning valuable money and is a wasteful use of energy.

The Sentinel system from Vent-Axia benefits the commercial building by providing:

- Lower energy consumption than traditional systems
- Reduced losses to ventilation under part occupancy
- Longer running life
- Reduced operating costs
- Savings in lifetime maintenance costs
- Ease of installation

**Vent-Axia**<sup>®</sup>

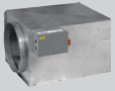

Sentinel D-Box Single Fan

M7-M16

---



Sentinel D-Box Twin Fan

M17-M26

---



Sentinel D-Box Sensors & Controls

M27-M28

---



# Sentinel D-Box Fans

- Ideal for multi-occupancy and intermittently used rooms
- System only runs to level required
- Avoids over-ventilation
- Reduces energy use



Sentinel is a range of ventilation systems for multi-occupancy and intermittently used rooms. Using energy efficient ducted fans with intelligent sensing and control, the system meets the ventilation requirements of both new builds and refurbishment projects.

Ideal for applications where rooms are used at different times of the day by a variable number of people, the Sentinel system will monitor occupancy, ventilation rate and air quality, and respond accordingly to maintain the atmosphere within preset limits.

---

## Typical Applications

A network of hotel bathrooms, flats or apartments, which require ventilation, but are only used in limited periods particularly in the morning and in the evening.

School classrooms and lecture theatres which are only occupied during lesson time by a variable number of students, but when used must keep CO<sub>2</sub> levels within prescribed limits.

Office meeting rooms or open plan areas which are used periodically during the day by a variable number of staff and visitors, but when occupied must meet required airflow rates.

Automatic sensing and control runs the system according to the maximum demand requirements of the building zone, whether it be carbon dioxide levels, temperature, humidity or air quality - triggered by people entering or leaving the rooms. Common configurations include Electronic Static Pressure (ESP) controllers for constant pressure systems.

---

## System Control

The precise control of the Sentinel system, driven by the ventilation requirements of the room means that the system is only running to the level required and only using energy when it is needed. A range of sensors are employed to determine the occupancy of the rooms and manage the system ventilation rates accordingly. This optimises the use of energy whilst meeting the legislation requirements of the building.

This compares to a 'traditional' fixed volume system, which in general is either 'ON' or 'OFF' often using energy to ventilate an empty or half occupied room, over ventilating and wasting energy.

---

## System Overview

The Sentinel System is made up of 3 parts: EC/DC Fan Motor, Sentinel Integral Control Unit, Sensors and Controls.

The ventilation demands of the room are detected by the wall, ceiling or duct mounted Sentinel sensors/switches. These communicate with the Sentinel control unit, which in turn drives the fan to the required speed to deliver the airflow. As the ventilation is provided to the room the sensors continuously feedback to the control unit, driving the fan motor to the exact level required in the room at any one time.

---

## Accessories

For duct accessories refer to Accessories Section.

---



Typical network of hotel bathrooms/flats/apartments



Typical school classroom

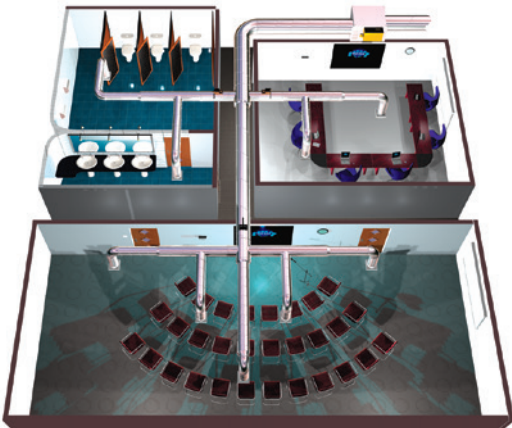

Typical office plan with conference facilities

## System Technology

Sentinel demand ventilation is a closed loop controlled ventilation system. Employing a range of sensors to manage the system, demand is sensed by PIR, temperature, humidity, air quality or carbon dioxide sensors. Depending on the levels in the rooms, Sentinel's fan speed is ramped up or down to control the parameters within the required limits. If the room is unoccupied, the system switches off, saving energy and cost to the business. Available in single or twin fan configurations, with twin allowing for load sharing or 'standby' for extra reliability.

## EC/DC Energy Saving Fan Motor Technology

Sentinel utilises the latest EC/DC motor technology, which provides energy saving benefits even over DC motors.



This technology is also infinitely speed controllable and offers increased energy savings across the complete speed control range when compared with conventional inverter drive solutions. The result is higher efficiency, reduced noise, accurate controllability, better speed control drawing less power and as a result better overall system performance.

Sentinel can be used in a hierarchal system where maximum demand, for example temperature and/or CO<sub>2</sub> gives priority control of the fan speed or a constant pressure system with room mounted PIR/grilles or in-line damper control.

## Highest Motor Efficiency

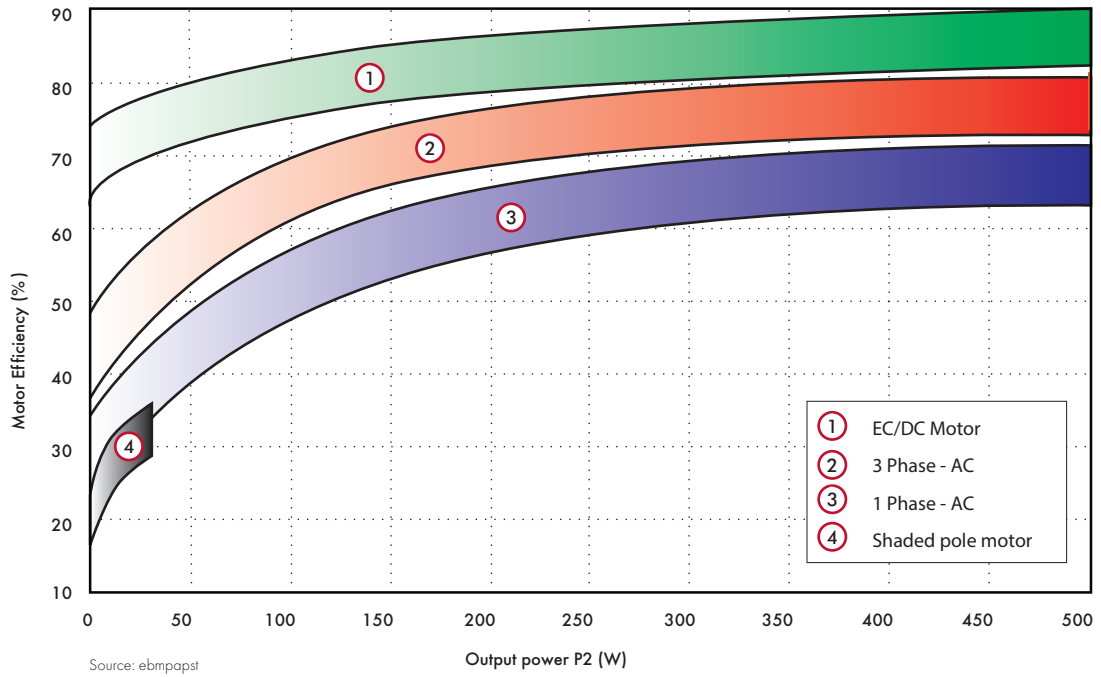

## Typical EC/AC Motor Speed Control Comparison

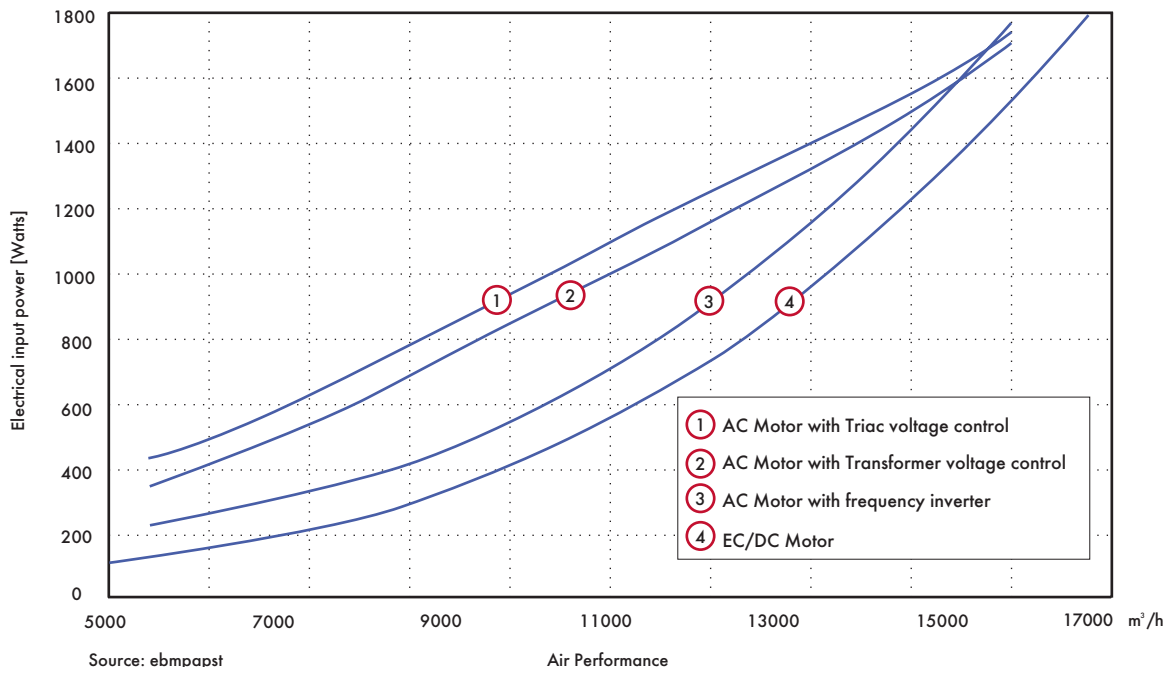

As can be seen from above motor comparisons, the EC/DC motor offers higher efficiencies when compared to AC motors, and also consumes less power under speed control, giving both the highest motor efficiency and lowest power consumption across the speed control range.

## Hierarchical Control



The system is controlled by on-board electronics, with an LCD display showing fan status and allowing for simple commissioning and installation, whether as a local sensor control unit or linked into a building management system.

### 1. Switched on/off or minimum/maximum level control

In an environment such as an office the system is activated and runs between minimum and maximum levels by a choice of sensors.

- AQS - Air Quality Sensor
- PIR Detector
- Thermostat
- Humidistat
- Time Clock
- BMS (remote enable)

### 2. Hierarchical - maximum demand multi-sensor input

Used with a combination of sensors, with a defined level of priorities to simultaneously control a number of atmospheric conditions within a room, such as a meeting room.

- CO<sub>2</sub>/temperature - room mounted
- CO<sub>2</sub> - duct mounted
- Manual speed adjuster
- Building Management System (0-10V)

## Constant Pressure Extract

Applied in a discreet central extract system, such as hotel bathrooms or apartment blocks, the system grilles and/or duct dampers are controlled by the presence of a person in the room or by achieving required levels of humidity. The central system will respond to the demand depending on the number of active rooms.

- PIR/Humidity Extract Grille 125mm
- PIR 12 - 70m<sup>3</sup>/h
- Humidity: 12m<sup>3</sup>/h @ 30% RH  
70m<sup>3</sup>/h @ 75% RH
- Motorised Duct Dampers 100mm - 315mm Dia
- Built in end stop adjustment for setting minimum and maximum volume
- 24V Min/Max or 0-10V proportional control options
- Motorised Duct Dampers - Sensor Control options
- Each 24V powered extract damper can be controlled by one of the following sensors:-

### Min-Max (DVDxxx/MM)

- AQS - Air Quality Sensor - Room (432953)
- PIR Detector - Room (433162)
- Thermostat - Room (563502)
- Humidistat - Room (432945)

### Proportional 0-10V (DVDxxx/PC)

- Carbon Dioxide Sensor - Room (433259)
- Carbon Dioxide Sensor - Duct (433259)
- Temperature Sensor - Room (434749)

**Note** Local 24V power supply required to power dampers & sensors (426526)

# Sentinel D-Box Single Fan

- Duct size 100 to 500mm
- Performance - Airflow 0.01 to 1.6m<sup>3</sup>/s
- Pressure up to 650Pa
- Sentinel demand ventilation fan controller with lockable isolator
- Aluzinc construction suitable for Internal or External mounting
- Performance tested to BS848 parts 1 & 2

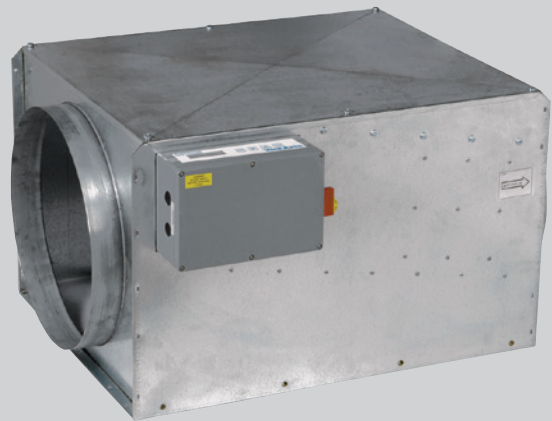

The Sentinel single in-line duct fans are as supplied from Vent-Axia Ltd. Manufactured from Aluzinc, Sentinel fan units are internally treated with an 'O' class rated, BS476 part 6 & 7 acoustic foam which offers the benefits of high sound absorption, good thermal insulation properties, in addition to self extinguishing properties and resistance to ignition.

The casing includes an inclined inlet and bellmouth entry which directs the incoming air to the impeller with minimal turbulence. The result is better air management through the unit, less noise, higher efficiency and an increased performance.

The housing is designed to be as compact as possible for concealed false ceiling applications and Sentinel casings are specially designed to allow the unit to be mounted via its unique mounting bracket, ensuring a quick and easy solution to installation.

---

## Impellers

All Sentinel units feature a low energy, Class 1, EC/DC external rotor motor and backward curved impeller assembly specifically chosen for performance and non-overloading characteristics. The assembly is dynamically balanced to DIN ISO 1940 Grade 6.3, duct size 500mm rated IP54, all other sizes IP44 according to BS EN 60529. Ball bearings are greased for life. Insulation is Class 'B' (from -25°C to +60°C). All models incorporate internal electronic overload protection and soft start function.

---

## Electrical

Every Sentinel unit is fitted with a purpose designed common PCB controller incorporating a 16-character backlit alphanumeric x 2 line display with 4 button membrane keypad for fan status and commissioning set up. The enclosure is fitted with a 4-pole 10A isolator that is suitable for fitting a locking device to prevent accidental operation.

Motors are single phase 230V +/- 10% / 50/60Hz / 1ph (size 100-400mm) or 400V +/- 10% / 50/60Hz / 3ph (size 500mm), (4 wire systems only).

24V DC power is provided from the controller for powering the matched range of Sentinel switches and sensors.

---

## Performance/Sound

Extensively tested to BS848 parts 1 & 2. Published dB(A) figures are free field sound pressure levels at 3m with spherical propagation at reference level of  $2 \times 10^{-5}$  Pa. The inlet/outlet sound power level spectra figures are dB with a reference of  $10^{-12}$  Watts.

---

## Accessories

For duct accessories see Ducting and Fitting Section.

---

## Fan Dimensions (mm)

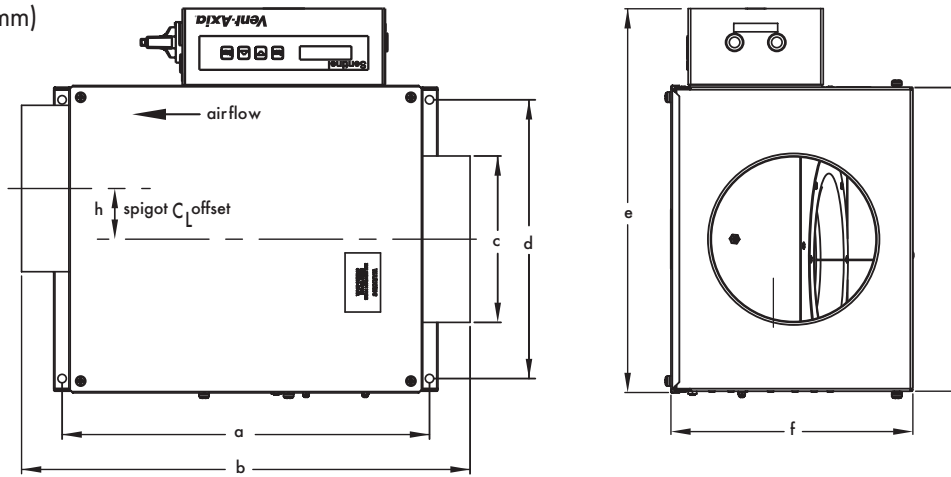

Constant

Hierarchy Model	Pressure Model	a	b	c	d	e	f	g	h	Weight kg
SENT100S	SENT100S/CP	380	443	100	275	400	192	306	62	8.5
SENT125S	SENT125S/CP	380	443	125	275	400	192	306	62	8.5
SENT150S	SENT150S/CP	380	443	150	275	400	192	306	62	8.5
SENT200S	SENT200S/CP	435	531	200	330	453	287	360	60	12.5
SENT250S	SENT250S/CP	435	531	250	330	453	287	360	35	13
SENT315S	SENT315S/CP	710	808	315	540	661	458	568	43	34
SENT400S	SENT400S/CP	710	808	400	540	661	458	568	43	36
SENT500S	SENT500S/CP	898	996	500	735	858	577	765	59	55

## Accessories

Hierarchy Model	Model	Anti-Vibration Mounts Stock Ref	Duct air heater Stock Ref	Filter cassette Stock Ref	Bag filter cassette Stock Ref	*Duct attenuator 600mm Stock Ref
SENT100S	SENT100S/CP	68MP033G	10531100T1	10532100A	10533100	10535100
SENT125S	SENT125S/CP	68MP033G	10531125T1	10532125A	10533125	10535125
SENT150S	SENT150S/CP	68MP033G	10531150T1	10532150A	10533150	10535150
SENT200S	SENT200S/CP	68MP033G	10531200T1	10532200A	10533200	10535200
SENT250S	SENT250S/CP	68MP033G	10531250T1	10532250A	10533250	10535250
SENT315S	SENT315S/CP	68MP033G	10531315T1	10532315A	10533315	10535315
SENT400S	SENT400S/CP	68MP033G	10531400T3	10532400A	10533400	10535400
SENT500S	SENT500S/CP	68MP033G	10531500T3	10532500A	10533500	10536500*

\*For alternative attenuator lengths, refer to Accessories and Controllers section

# Performance Guide

Sentinel 100 Single Fan

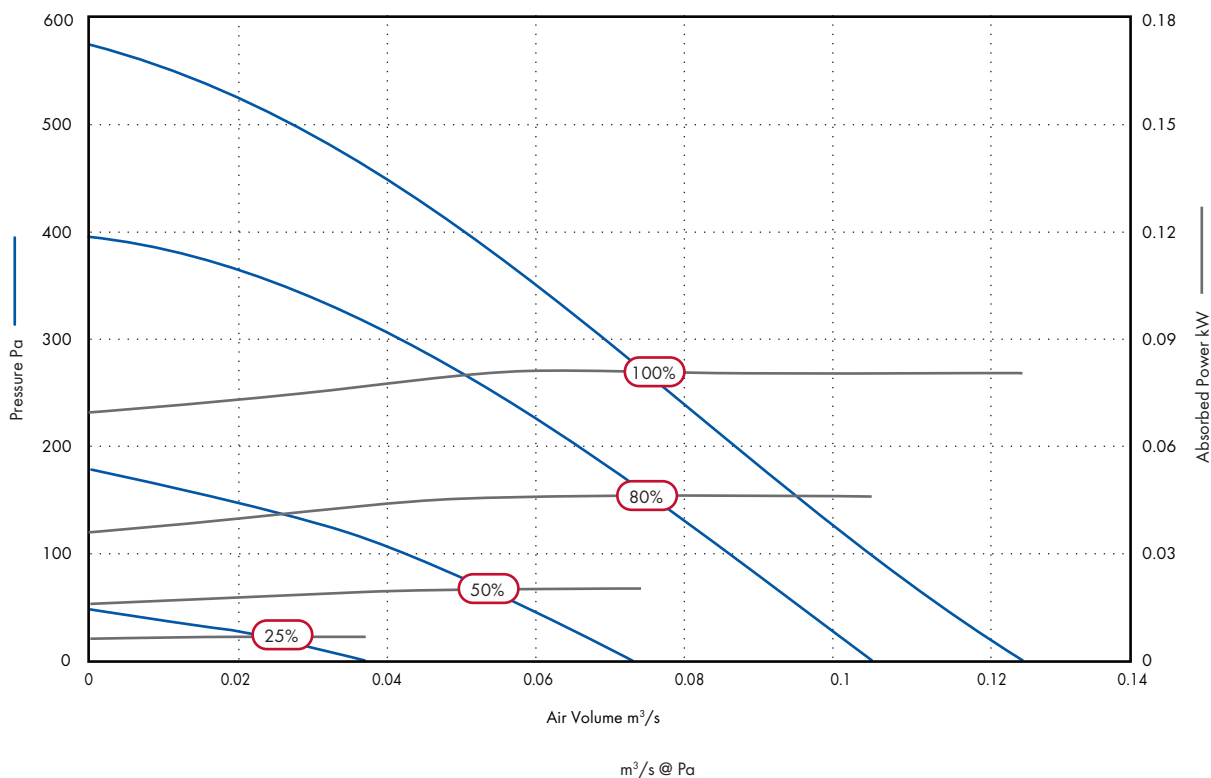

Speed	Motor Phase		0	50	100	200	300	400	500	F.L.C Amps
25	1	m³/s	0.04							0.08
		SFP	0.18							
		Watts	0.01							
50	1	m³/s	0.07	0.06	0.04					0.15
		SFP	0.29	0.33	0.50					
		Watts	0.02	0.02	0.02					
80	1	m³/s	0.11	0.10	0.09	0.07	0.04			0.5
		SFP	0.42	0.47	0.52	0.66	1.13			
		Watts	0.05	0.05	0.05	0.05	0.05			
100	1	m³/s	0.13	0.12	0.11	0.09	0.07	0.05	0.03	0.72
		SFP	0.62	0.68	0.74	0.90	1.16	1.60	2.53	
		Watts	0.08	0.08	0.08	0.08	0.08	0.08	0.08	

## Sound Data

Speed	Test Mode	Octave Band Frequency SWL								dB(A) @ 3m
		63	125	250	500	1k	2k	4k	8k	
25	Breakout	44	39	35	27	24	22	23	29	17
	Inlet	43	43	40	35	26	22	22	29	19
	Outlet	46	40	41	35	29	23	22	30	20
50	Breakout	50	48	47	37	32	29	26	30	23
	Inlet	48	52	62	54	41	34	28	30	35
	Outlet	49	52	67	57	48	44	38	31	39
80	Breakout	55	58	56	48	42	41	38	33	31
	Inlet	55	58	67	67	53	47	41	35	45
	Outlet	56	59	68	68	61	56	51	42	47
100	Breakout	64	63	60	55	47	46	44	38	36
	Inlet	57	62	68	71	58	52	47	41	48
	Outlet	57	63	71	72	66	62	55	48	52

# Performance Guide

Sentinel 125 Single Fan

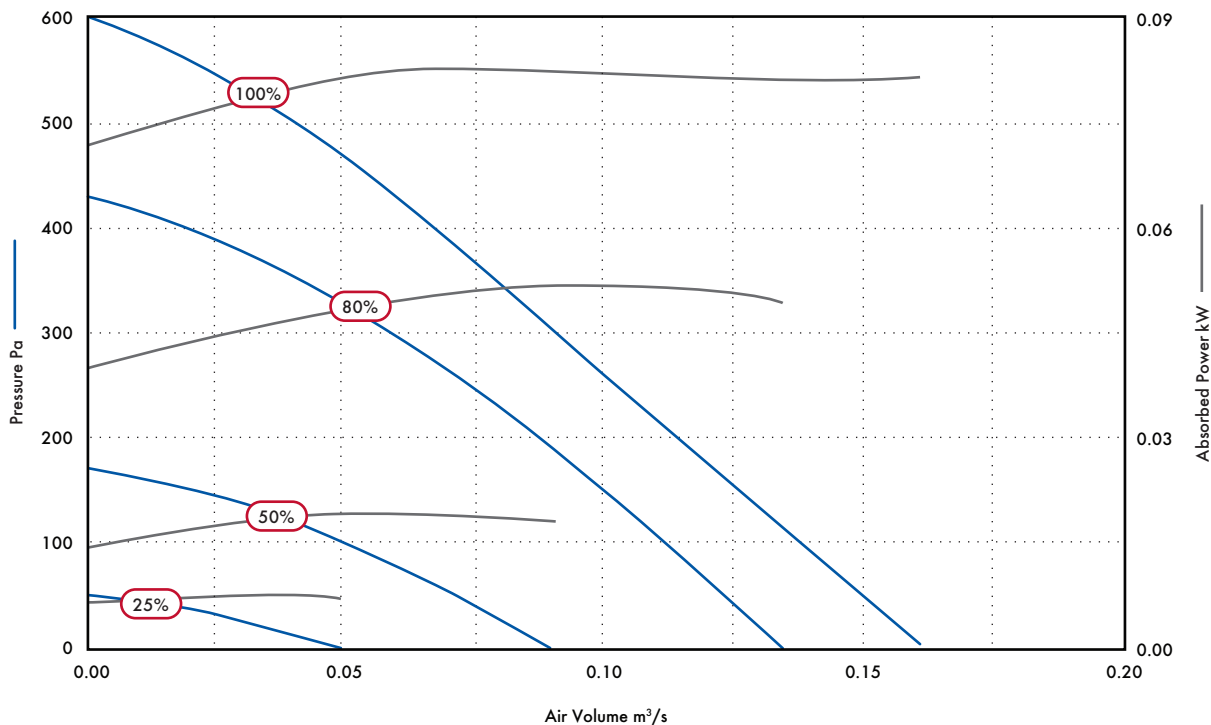

Airflow, m³/s @ Pa

Speed	Motor Phase	0	50	100	200	300	400	500	F.L.C Amps	
25	1	m³/s	0.05						0.09	
		SFP	0.14							
		Watts	0.01							
50	1	m³/s	0.09	0.07	0.05				0.18	
		SFP	0.21	0.27	0.38					
		Watts	0.02	0.02	0.02					
80	1	m³/s	0.14	0.13	0.11	0.09	0.06	0.02	0.51	
		SFP	0.35	0.39	0.47	0.58	0.83	2.20		
		Watts	0.05	0.05	0.05	0.05	0.05	0.04		
100	1	m³/s	0.16	0.15	0.14	0.11	0.09	0.07	0.04	0.72
		SFP	0.51	0.54	0.58	0.75	0.92	1.17	2.00	
		Watts	0.08	0.08	0.08	0.08	0.08	0.08	0.08	

## Sound Data

Octave Band Frequency SWL

Speed	Test Mode	63	125	250	500	1k	2k	4k	8k	dB(A) @ 3m
25	Breakout	49	40	34	28	26	24	23	29	18
	Inlet	46	44	41	35	27	22	22	28	20
	Outlet	47	47	42	36	33	27	22	29	21
50	Breakout	53	49	49	39	34	28	23	29	24
	Inlet	50	56	58	53	43	37	31	29	33
	Outlet	50	56	58	53	43	37	31	29	37
80	Breakout	55	55	58	50	46	39	31	31	33
	Inlet	54	64	68	64	55	49	43	36	44
	Outlet	56	67	72	66	64	60	55	45	49
100	Breakout	62	58	59	57	52	46	37	33	37
	Inlet	58	69	70	70	60	56	48	42	49
	Outlet	58	70	71	73	70	67	60	52	54



Performance Guide

Sentinel 150 Single Fan

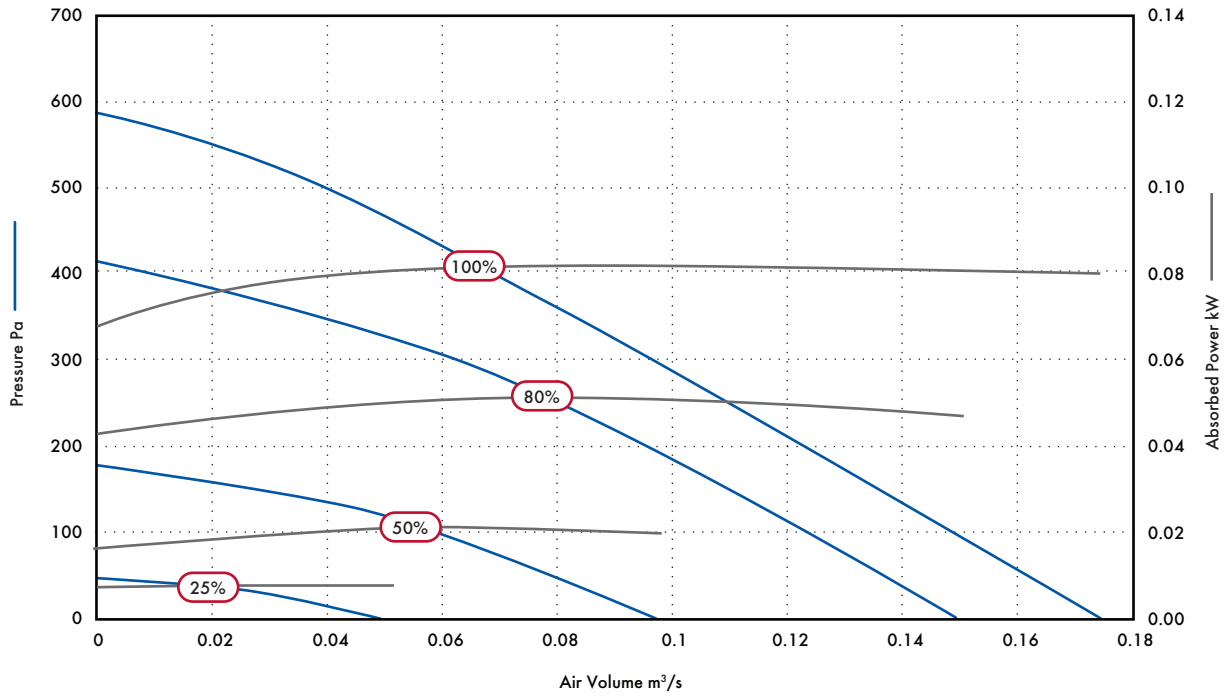

Speed	Motor Phase	Airflow, m³/s @ Pa								F.L.C Amps
		0	50	100	200	300	400	500		
25	1	m³/s	0.05							0.08
		SFP	0.14							
		kW	0.01	0.01						
50	1	m³/s	0.10	0.08	0.06					0.16
		SFP	0.19	0.25	0.35					
		kW	0.02	0.02	0.02					
80	1	m³/s	0.15	0.14	0.12	0.10	0.06	0.01		0.48
		SFP	0.31	0.34	0.41	0.51	0.85	4.50		
		kW	0.05	0.05	0.05	0.05	0.05	0.05		
100	1	m³/s	0.17	0.16	0.15	0.12	0.10	0.07	0.04	0.74
		SFP	0.47	0.51	0.54	0.68	0.81	1.16	2.00	
		kW	0.08	0.08	0.08	0.08	0.08	0.08	0.08	

Sound Data

Speed	Test Mode	Octave Band Frequency SWL								dB(A) @ 3m
		63	125	250	500	1k	2k	4k	8k	
25	Breakout	46	43	36	28	26	23	24	29	18
	Inlet	46	45	42	37	30	24	23	29	21
	Outlet	43	45	42	37	35	31	22	28	22
50	Breakout	50	50	50	40	35	28	24	29	25
	Inlet	50	56	60	56	46	41	36	30	35
	Outlet	51	59	61	56	53	51	46	33	38
80	Breakout	53	57	57	51	48	42	36	31	33
	Inlet	57	65	71	66	58	52	44	42	46
	Outlet	56	67	75	67	65	63	56	50	50
100	Breakout	62	61	59	60	54	49	43	37	39
	Inlet	59	68	72	76	64	58	51	48	54
	Outlet	59	70	74	76	71	70	64	58	56

# Performance Guide

Sentinel 200 Single Fan

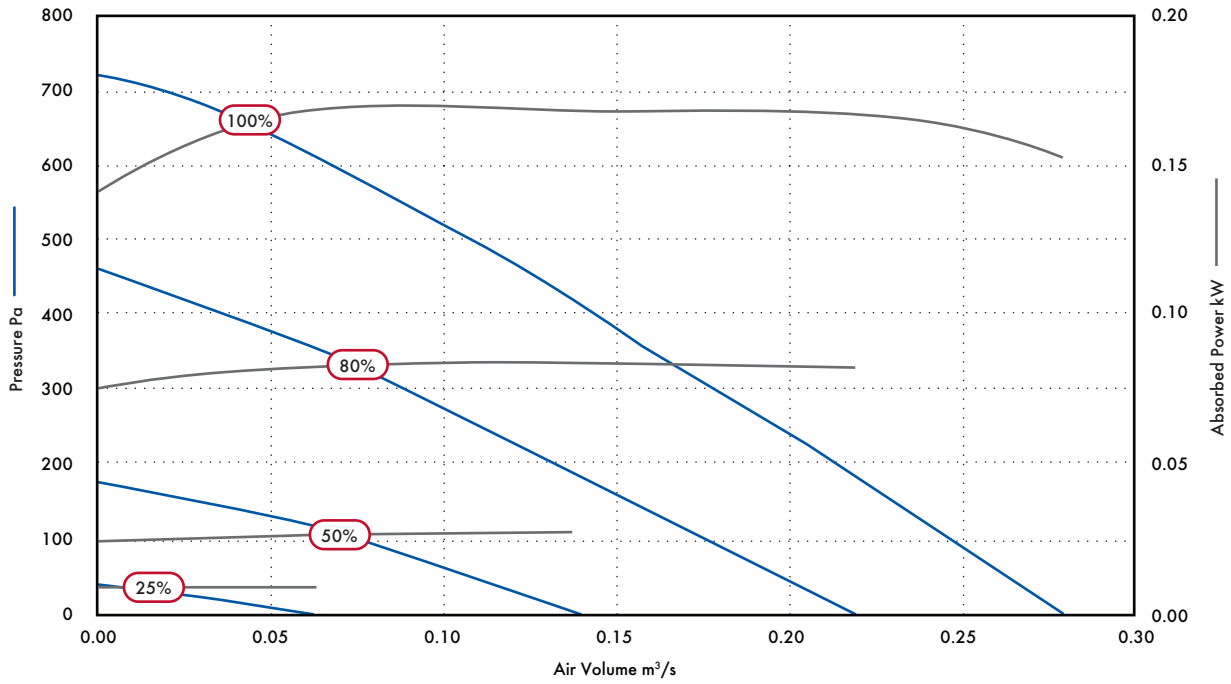

Speed	Motor Phase	Airflow, m³/s @ Pa										F.L.C Amps	
		0	50	100	200	300	400	500	600	700			
25	1	m³/s	0.06										
		SFP	0.13										0.08
		kW	0.01										
50	1	m³/s	0.14	0.11	0.08								
		SFP	0.19	0.25	0.34								0.16
		kW	0.03	0.03	0.03								
80	1	m³/s	0.22	0.20	0.18	0.13	0.09	0.04					
		SFP	0.37	0.42	0.46	0.65	0.88	2					0.5
		kW	0.08	0.08	0.08	0.08	0.08	0.08					
100	1	m³/s	0.28	0.26	0.25	0.21	0.18	0.14	0.11	0.07	0.02		
		SFP	0.54	0.61	0.65	0.80	0.93	1.20	1.54	2.41	7.75		0.72
		kW	0.15	0.16	0.16	0.17	0.17	0.17	0.17	0.17	0.17	0.16	

## Sound Data

Speed	Test Mode	Octave Band Frequency SWL								dB(A) @ 3m
		63	125	250	500	1k	2k	4k	8k	
25	Breakout	48	41	39	30	29	26	24	31	20
	Inlet	50	52	49	43	34	32	24	30	26
	Outlet	46	55	48	43	39	42	29	30	28
50	Breakout	55	53	55	42	41	37	34	32	29
	Inlet	54	57	67	62	51	44	47	40	41
	Outlet	55	59	67	62	58	56	55	46	44
80	Breakout	66	63	63	52	47	46	45	44	37
	Inlet	63	66	68	77	64	57	56	53	54
	Outlet	65	68	66	76	71	69	65	61	56
100	Breakout	63	69	66	60	53	51	50	50	42
	Inlet	68	71	72	77	70	63	61	57	56
	Outlet	70	72	69	80	76	76	72	65	62

# Performance Guide

## Sentinel 250 Single Fan

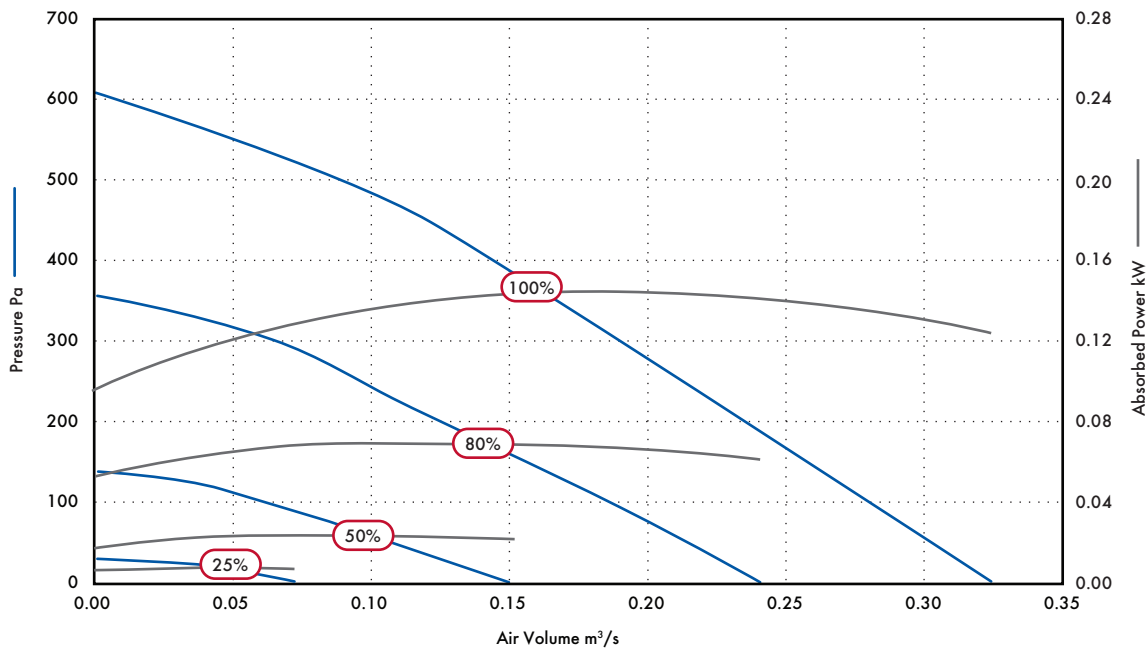

Speed	Motor Phase	Airflow, m³/s @ Pa									F.L.C Amps	
		0	50	100	200	300	400	500	600			
25	1	m³/s	0.07									0.07
		SFP	0.11									
		kW	0.01									
50	1	m³/s	0.15	0.11	0.07						0.2	
		SFP	0.15	0.22	0.34							
		kW	0.02	0.02	0.02							
80	1	m³/s	0.24	0.22	0.19	0.13	0.07				1	
		SFP	0.26	0.30	0.36	0.52	1					
		kW	0.06	0.07	0.07	0.07	0.07					
100	1	m³/s	0.33	0.30	0.28	0.24	0.19	0.15	0.09	0.01	1.38	
		SFP	0.37	0.44	0.49	0.59	0.77	0.97	1.48	3.70		
		kW	0.12	0.13	0.14	0.14	0.15	0.15	0.13	0.04		

## Sound Data

Speed	Test Mode	Octave Band Frequency SWL								dB(A) @ 3m
		63	125	250	500	1k	2k	4k	8k	
25	Breakout	42	42	37	31	29	26	25	31	19
	Inlet	48	49	42	38	35	24	24	29	22
	Outlet	47	46	41	37	41	29	24	29	24
50	Breakout	52	48	53	43	37	36	34	30	27
	Inlet	55	57	65	58	49	43	45	38	39
	Outlet	53	57	62	58	54	55	51	36	41
80	Breakout	54	56	57	57	48	46	45	36	36
	Inlet	63	65	69	76	62	54	53	49	53
	Outlet	63	66	69	72	69	68	62	55	54
100	Breakout	61	63	62	62	55	54	52	45	42
	Inlet	68	71	72	80	68	62	59	56	58
	Outlet	68	71	70	78	75	75	68	63	60

Performance Guide

Sentinel 315 Single Fan

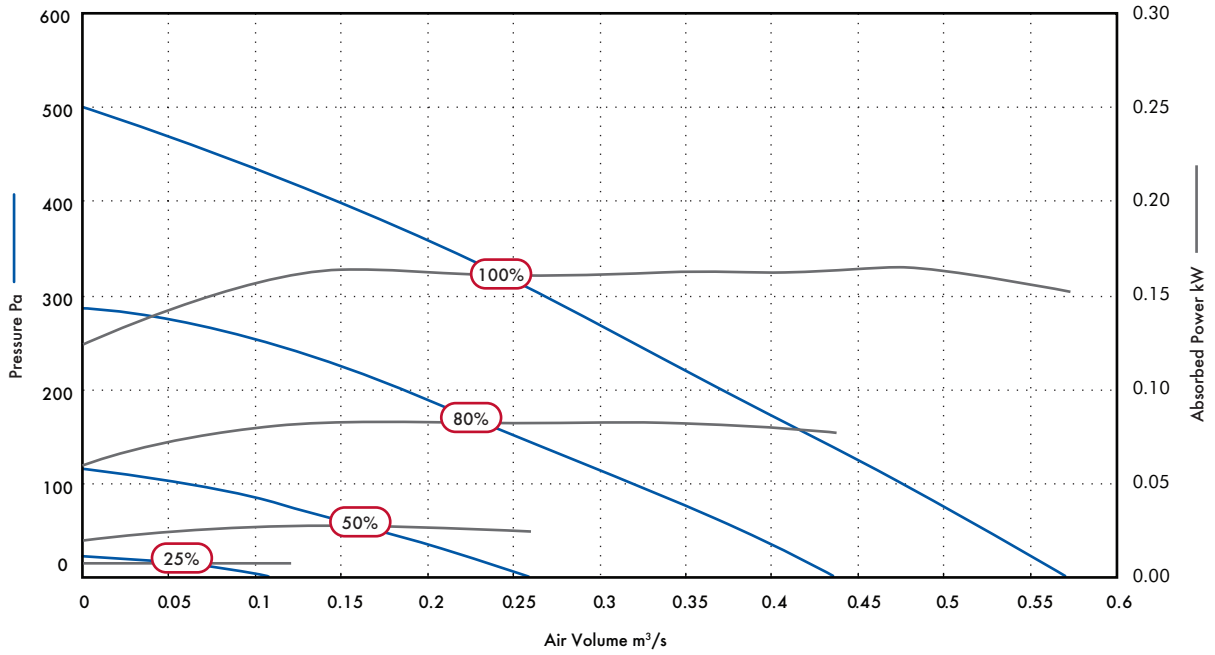

Speed	Phase	Airflow, m <sup>3</sup> /s @ Pa							F.L.C Amps
		0	50	100	200	300	400		
25	1	m <sup>3</sup> /s	0.12						0.08
		SFP	0.06						
		kW	0.01						
50	1	m <sup>3</sup> /s	0.26	0.17	0.06			0.19	
		SFP	0.10	0.16	0.42				
		kW	0.03	0.03	0.03				
80	1	m <sup>3</sup> /s	0.44	0.39	0.32	0.18		0.50	
		SFP	0.18	0.21	0.26	0.46			
		kW	0.08	0.08	0.08	0.08			
100	1	m <sup>3</sup> /s	0.57	0.53	0.48	0.37	0.26	0.15	1.36
		SFP	0.27	0.30	0.34	0.44	0.62	1.09	
		kW	0.15	0.16	0.16	0.16	0.16	0.16	

Sound Data

Speed	Test Mode	Octave Band Frequency SWL								dB(A) @ 3m
		63	125	250	500	1k	2k	4k	8k	
25	Breakout	45	42	44	32	30	26	25	31	21
	Inlet	47	43	40	31	28	22	23	29	19
	Outlet	47	44	42	37	33	27	25	29	21
50	Breakout	54	56	48	46	36	30	26	31	27
	Inlet	61	63	54	47	44	39	32	30	31
	Outlet	60	63	55	55	51	49	42	31	37
80	Breakout	57	68	60	49	45	42	36	32	38
	Inlet	62	78	67	59	55	51	45	40	44
	Outlet	62	82	68	66	64	61	55	46	50
100	Breakout	62	69	69	56	53	47	43	36	44
	Inlet	67	78	79	66	61	58	53	45	51
	Outlet	66	78	78	73	70	68	63	55	56

# Performance Guide

## Sentinel 400 Single Fan

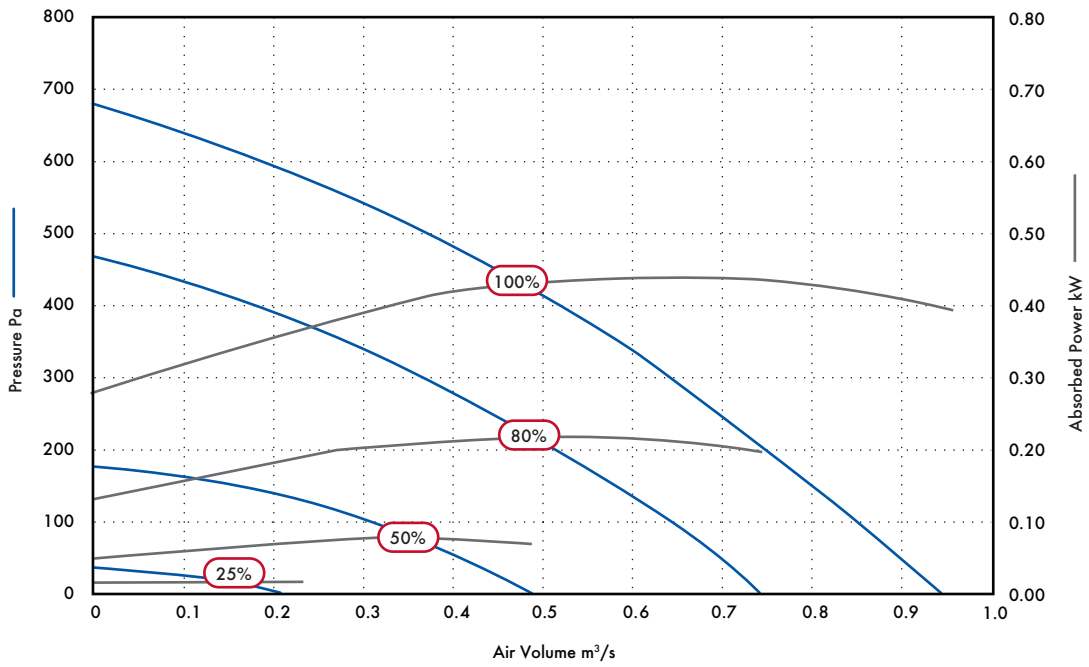

Speed	Phase	Airflow, m³/s @ Pa								F.L.C Amps	
		0	50	100	200	300	400	500	600		
25	1	m³/s	0.24								0.13
		SFP	0.07								
		kW	0.02								
50	1	m³/s	0.50	0.42	0.32						0.59
		SFP	0.14	0.19	0.25						
		kW	0.07	0.08	0.08						
80	1	m³/s	0.74	0.71	0.65	0.51	0.37	0.19			1.80
		SFP	0.27	0.29	0.33	0.43	0.58	0.96			
		kW	0.20	0.21	0.21	0.22	0.21	0.18			
100	1	m³/s	0.95	0.90	0.85	0.75	0.64	0.52	0.38	0.20	2.47
		SFP	0.42	0.45	0.49	0.58	0.69	0.84	1.09	1.79	
		kW	0.40	0.41	0.42	0.44	0.44	0.44	0.42	0.36	

## Sound Data

Speed	Test Mode	Octave Band Frequency SWL								dB(A) @ 3m
		63	125	250	500	1k	2k	4k	8k	
25	Breakout	44	40	46	35	29	26	24	31	21
	Inlet	50	48	48	39	30	23	24	30	23
	Outlet	51	48	47	42	38	28	25	29	25
50	Breakout	56	68	54	45	41	34	26	30	33
	Inlet	69	74	65	56	52	48	38	33	41
	Outlet	68	72	65	62	61	57	48	39	45
80	Breakout	63	73	68	57	52	44	38	32	42
	Inlet	74	82	78	68	64	61	56	47	53
	Outlet	75	87	77	75	73	70	64	55	58
100	Breakout	67	73	76	63	58	50	44	40	48
	Inlet	78	83	87	73	69	66	61	54	59
	Outlet	78	85	92	80	79	75	69	61	65

Performance Guide

Sentinel 500 Single Fan

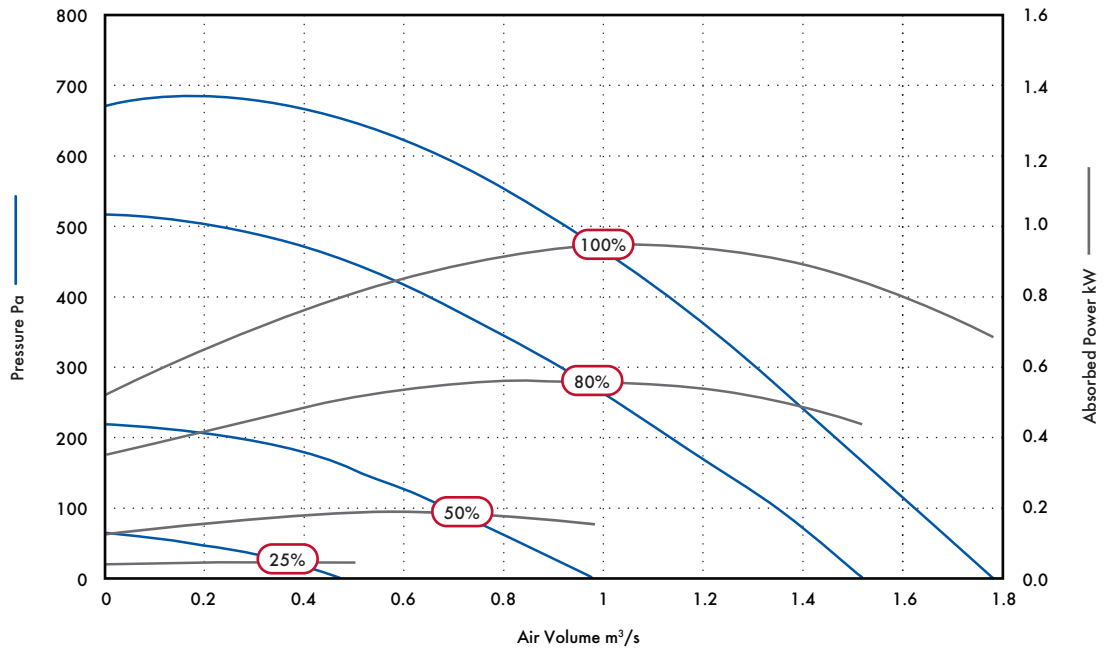

Speed	Phase	Airflow, m³/s @ Pa									F.L.C Amps	
		0	50	100	200	300	400	500	600			
25	3	m³/s	0.50	0.20								0.32
		SFP	0.08	0.21								
		kW	0.04	0.04								
50	3	m³/s	0.99	0.83	0.68	0.27					0.5	
		SFP	0.15	0.20	0.26	0.59						
		kW	0.15	0.17	0.18	0.16						
80	3	m³/s	1.53	1.45	1.37	1.14	0.92	0.65	0.23		0.9	
		SFP	0.28	0.32	0.37	0.47	0.60	0.83	1.89			
		kW	0.43	0.47	0.50	0.54	0.56	0.54	0.43			
100	3	m³/s	1.79	1.71	1.63	1.47	1.31	1.13	0.93	0.67	1.2	
		SFP	0.38	0.43	0.48	0.58	0.70	0.84	1.02	1.31		
		kW	0.68	0.73	0.78	0.86	0.92	0.95	0.94	0.88		

Sound Data

Speed	Test Mode	Octave Band Frequency SWL								dB(A) @ 3m
		63	125	250	500	1k	2k	4k	8k	
25	Breakout	44	39	35	27	24	22	23	29	17
	Inlet	43	43	40	35	26	22	22	29	19
	Outlet	46	40	41	35	29	23	22	30	20
50	Breakout	50	48	47	37	32	29	26	30	23
	Inlet	48	52	62	54	41	34	28	30	35
	Outlet	49	52	67	57	48	44	38	31	39
80	Breakout	55	58	56	48	42	41	38	33	31
	Inlet	55	58	67	67	53	47	41	35	45
	Outlet	56	59	68	68	61	56	51	42	47
100	Breakout	64	63	60	55	47	46	44	38	36
	Inlet	57	62	68	71	58	52	47	41	48
	Outlet	57	63	71	72	66	62	55	48	52

# Sentinel D-Box Twin Fan

- Duct Sizes 100 - 500mm
- Performance - Airflow 0.01 to 1.3m<sup>3</sup>/s, Pressure up to 650Pa
- Sentinel demand ventilation fan controller with lockable isolator
- Latest energy saving EC/DC motors
- Aluzinc construction suitable for internal or external mounting
- Manufactured controlled to BS EN ISO 9001:2015
- Performance tested to BS848 Part 1 & 2



The Sentinel twin in-line duct fans are as supplied from Vent-Axia Ltd. Manufactured from Aluzinc, Sentinel fan units are internally treated with an 'O' class rated, BS476 part 6 & 7, acoustic foam which offers the benefits of high sound absorption, good thermal insulation properties in addition to self extinguishing properties and resistant to ignition.

Weatherproof external units incorporate an additional controller shroud.

The housing is designed to be as compact as possible for concealed false ceiling applications and Sentinel casings are specially designed to allow the unit to be mounted via its unique mounting bracket, ensuring a quick and easy solution to installation.

The unit is suitable for ceiling or floor mounting, non-return dampers can be easily rotated on site to suit.

---

## Impellers

All Sentinel units feature a low energy, Class 1, EC/DC external rotor motor and backward curved impeller assembly specifically chosen for performance and non-overloading characteristics. The assembly is dynamically balanced to DIN ISO 1940 Grade 6.3, duct size 500mm rated IP54, all other sizes, IP44 according to BS EN 60529. Ball bearings are greased for life. Insulation is Class 'B' (from -25°C to +60°C).

All models incorporate internal electronic overload protection and soft start function.

---

## Electrical

Every Sentinel unit is fitted with a purpose designed common PCB controller incorporating a 16-character backlit alphanumeric x 2 line display with 4 button membrane keypad for fan status & commissioning set up. The enclosure is fitted with a 4-pole 10A isolator that is suitable for fitting a locking device to prevent accidental operation.

The twin unit controller features automatic 6hr duty/share and run/standby in the event of motor failure.

Motors are single phase 230V +/- 10% / 50/60Hz / 1ph (size 100-400mm) or 400V +/- 10% / 50/60Hz / 3ph (size 500mm), (4 wire systems only).

24V DC power is provided from the controller for powering the matched range of Sentinel switches and sensors.

---

## Performance/Sound

Extensively tested to BS848 parts 1 & 2. Published dB(A) figures are free field sound pressure levels at 3m with spherical propagation at reference level of  $2 \times 10^{-5}$  Pa. The inlet/outlet sound power level spectra figures are dB with a reference of  $10^{-12}$  Watts.

---

## Accessories

For duct accessories see Ducting and Fitting Section.

---

## Fan Dimensions (mm)

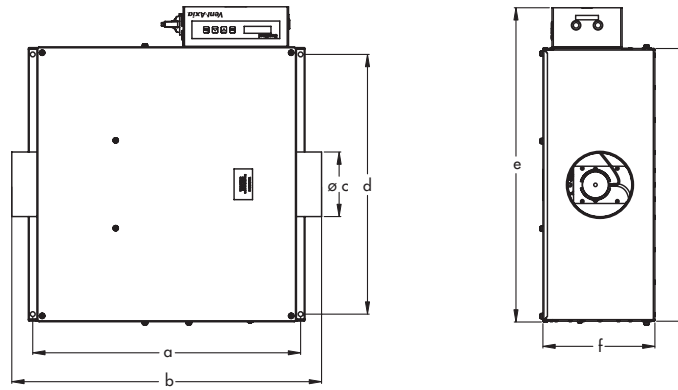

Hierarchy Model	Constant Pressure Model	Duct Diameter mm							Weight Kg
		a	b	c	d	e	f	g	
SENT100T	SENT100T/CP	610	705	100	591	717	256	622	26
SENT125T	SENT125T/CP	610	705	125	591	717	256	622	26
SENT150T	SENT150T/CP	610	705	150	591	717	256	622	26
SENT200T	SENT200T/CP	801	896	200	703	830	343	734	39
SENT250T	SENT250T/CP	925	1020	250	798	925	354	829	48
SENT315T	SENT315T/CP	1255	1353	315	1145	1272	536	1176	88
SENT400T	SENT400T/CP	1255	1353	400	1145	1272	536	1176	90
SENT500T	SENT500T/CP	1492	1590	500	1533	1661	675	1564	175

## Accessories

Hierarchy Model	Model	Anti-Vibration	Duct air heater Stock Ref.	Filter cassette Stock Ref.	Bag filter cassette Stock Ref.	*Duct
		mounts Stock Ref.				attenuator 600mm Stock Ref.
SENT100T	SENT100T/CP	68MP033G 68MP033G	10531100T1	10532100A	10533100	10535100
SENT125T	SENT125T/CP	68MP033G 68MP033G	10531125T1	10532125A	10533125	10535125
SENT150T	SENT150T/CP	68MP033G 68MP033G	10531150T1	10532150A	10533150	10535150
SENT200T	SENT200T/CP	68MP033G 68MP033G	10531200T1	10532200A	10533200	10535200
SENT250T	SENT250T/CP	68MP033G 68MP033G	10531250T1	10532250A	10533250	10535250
SENT315T	SENT315T/CP	68MP033G 68MP033G	10531315T1	10532315A	10533315	10535315
SENT400T	SENT400T/CP	68MP033G 68MP033G	10531400T3	10532400A	10533400	10535400
SENT500T	SENT500T/CP	68MP133G 68MP133G	10531500T3	10532500A	10533500	10536500*

\*For alternative attenuator lengths, refer to Accessories and Controllers section



# Performance Guide

## Sentinel 100 Twin Fan

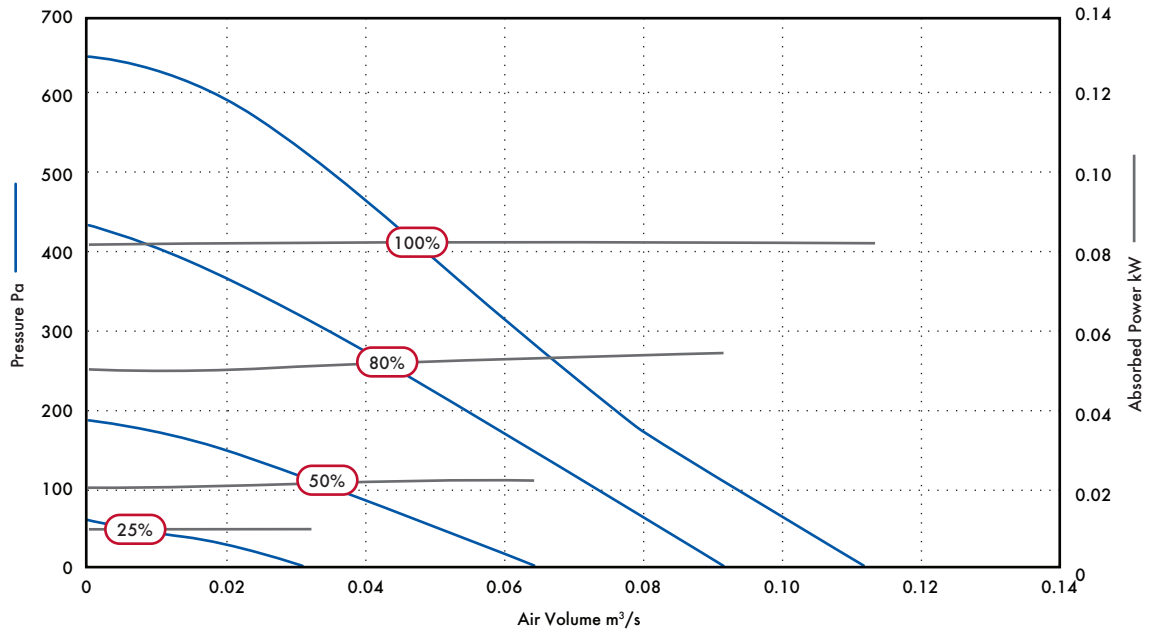

Speed	Motor Phase	Airflow, m³/s @ Pa								F.L.C Amps
		0	50	100	200	300	400	500		
25	1	m³/s	0.03	0.01						
		SFP	0.30	0.90						0.08
		kW	0.01	0.01						
50	1	m³/s	0.06	0.05	0.04					
		SFP	0.38	0.44	0.53					0.16
		kW	0.02	0.02	0.02					
80	1	m³/s	0.09	0.08	0.07	0.05	0.03	0.01		
		SFP	0.61	0.69	0.79	1.08	1.70	4.90		0.50
		kW	0.06	0.06	0.06	0.05	0.05	0.05		
100	1	m³/s	0.11	0.10	0.09	0.08	0.06	0.05	0.04	
		SFP	0.75	0.83	0.92	1.04	1.38	1.66	2.08	0.69
		kW	0.08	0.08	0.08	0.08	0.08	0.08	0.08	

## Sound Data

Speed	Test Mode	Octave Band Frequency SWL								dB(A) @ 3m
		63	125	250	500	1k	2k	4k	8k	
25	Breakout	45	39	35	27	25	23	23	30	17
	Inlet	45	38	41	29	25	21	22	29	18
	Outlet	43	39	34	28	24	22	23	28	17
50	Breakout	47	55	47	35	28	24	24	29	23
	Inlet	48	50	43	37	32	28	22	28	22
	Outlet	47	52	46	42	38	35	26	29	25
80	Breakout	55	64	58	45	38	35	32	32	32
	Inlet	54	58	54	51	44	40	31	30	32
	Outlet	51	61	59	56	50	49	40	34	37
100	Breakout	65	69	61	50	42	40	37	36	36
	Inlet	55	63	56	53	49	45	38	34	35
	Outlet	53	65	59	58	54	55	48	39	40

Performance Guide

Sentinel 125 Twin Fan

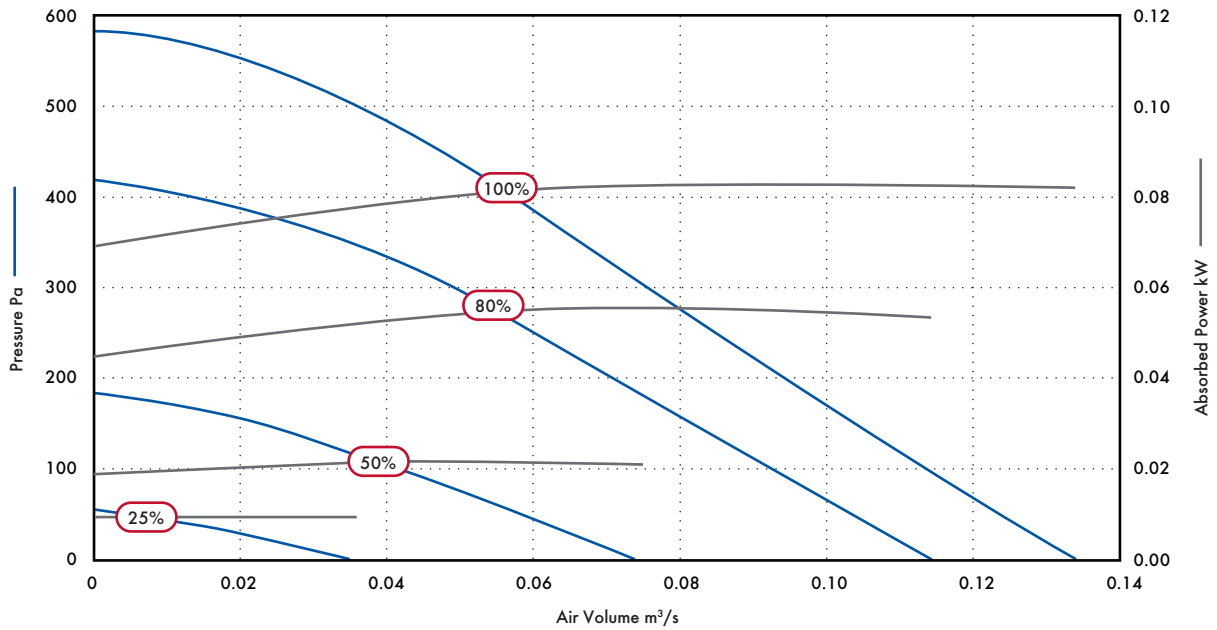

Speed	Motor Phase	Airflow, m³/s @ Pa								F.L.C Amps
		0	50	100	200	300	400	500		
25	1	m³/s	0.04							
		SFP	0.25							0.09
		kW	0.01							
50	1	m³/s	0.07	0.06	0.04					
		SFP	0.31	0.37	0.55					0.18
		kW	0.02	0.02	0.02					
80	1	m³/s	0.12	0.10	0.09	0.07	0.05	0.02		
		SFP	0.45	0.54	0.61	0.79	1.06	2.45		0.51
		kW	0.05	0.05	0.06	0.06	0.05	0.05		
100	1	m³/s	0.13	0.12	0.11	0.09	0.08	0.06	0.03	
		SFP	0.63	0.68	0.75	0.92	1.04	1.35	2.60	0.72
		kW	0.08	0.08	0.08	0.08	0.08	0.08	0.08	

Sound Data

Speed	Test Mode	Octave Band Frequency SWL								dB(A) @ 3m
		63	125	250	500	1k	2k	4k	8k	
25	Breakout	48	39	35	28	25	23	24	30	18
	Inlet	46	41	34	27	24	21	22	29	17
	Outlet	44	41	36	29	25	21	22	28	17
50	Breakout	49	56	48	35	33	25	25	30	25
	Inlet	49	56	50	40	34	31	23	29	26
	Outlet	49	60	56	45	40	37	27	29	30
80	Breakout	56	66	59	45	35	31	31	32	33
	Inlet	48	60	56	51	44	40	31	30	33
	Outlet	53	66	61	56	52	51	45	34	39
100	Breakout	59	72	64	52	41	36	35	36	39
	Inlet	52	66	66	56	51	47	38	39	39
	Outlet	54	69	64	61	57	57	52	43	44

Performance Guide

Sentinel 150 Twin Fan

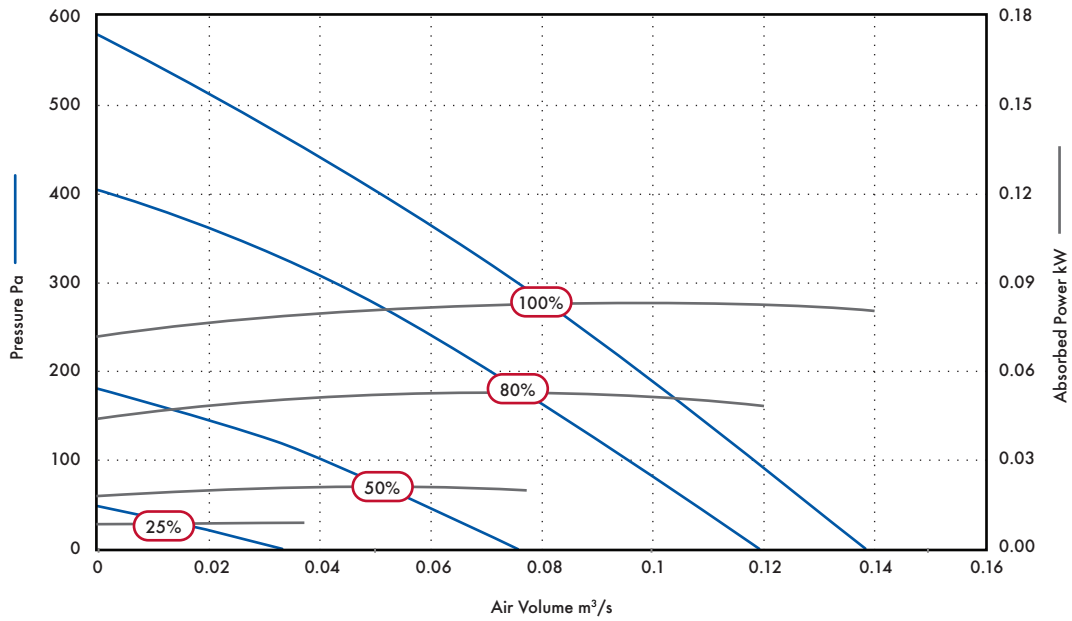

Airflow, m³/s @ Pa

Speed	Motor Phase	0	50	100	200	300	400	500	F.L.C Amps	
25	1	m³/s	0.04						0.08	
		SFP	0.23							
		kW	0.01							
50	1	m³/s	0.08	0.06	0.04				0.17	
		SFP	0.25	0.35	0.53					
		kW	0.02	0.02	0.02					
80	1	m³/s	0.12	0.11	0.09	0.07	0.04		0.48	
		SFP	0.40	0.45	0.58	0.76	1.30			
		kW	0.05	0.05	0.05	0.05	0.05			
100	1	m³/s	0.14	0.13	0.12	0.10	0.08	0.05	0.02	0.71
		SFP	0.58	0.63	0.69	0.83	1.03	1.60	3.85	
		kW	0.08	0.08	0.08	0.08	0.08	0.08	0.08	

Sound Data

Speed	Test Mode	Octave Band Frequency SWL								dB(A) @ 3m
		63	125	250	500	1k	2k	4k	8k	
25	Breakout	46	40	35	27	26	23	23	29	17
	Inlet	45	39	36	28	27	24	22	29	18
	Outlet	47	43	36	30	26	23	22	28	21
50	Breakout	48	52	49	37	31	26	23	29	24
	Inlet	47	55	48	41	33	30	23	29	25
	Outlet	49	59	56	44	42	40	32	29	30
80	Breakout	55	58	58	49	45	41	38	32	33
	Inlet	54	62	64	52	45	41	33	32	36
	Outlet	55	67	66	57	53	53	47	38	41
100	Breakout	60	63	62	59	51	47	42	41	39
	Inlet	58	66	66	59	50	46	39	36	40
	Outlet	60	71	67	64	61	61	55	49	47

# Performance Guide

Sentinel 200 Twin Fan

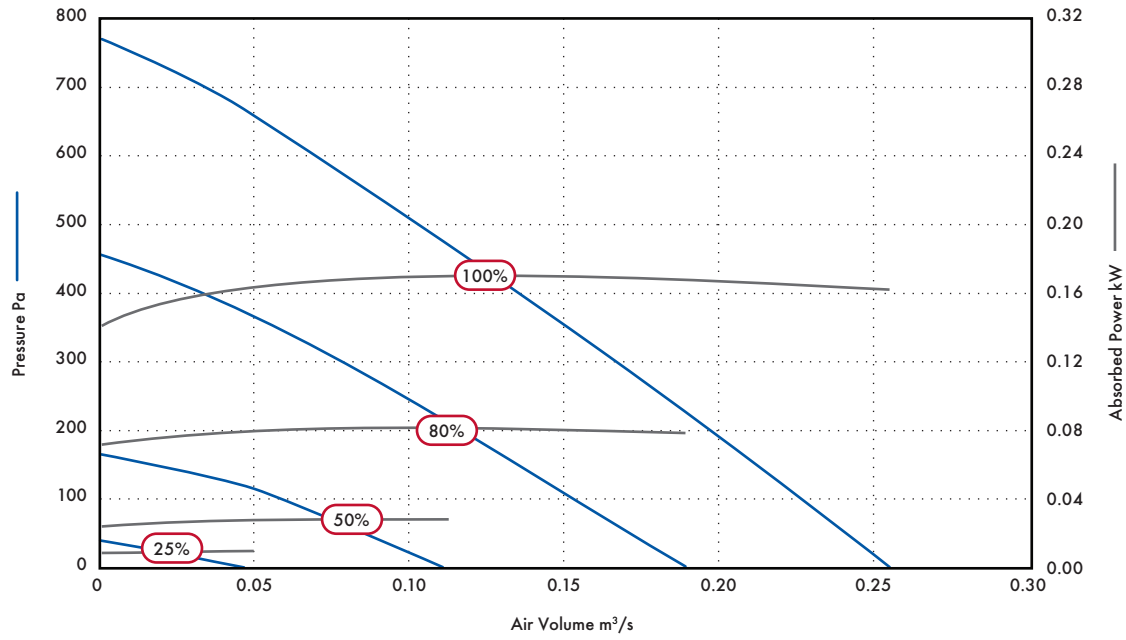

Airflow, m³/s @ Pa

Speed	Motor Phase	0	50	100	200	300	400	500	600	700	F.L.C Amps	
25	1	m³/s	0.05									
		SFP	0.20									0.09
		kW	0.01									
50	1	m³/s	0.11	0.08	0.06							
		SFP	0.25	0.35	0.47							0.2
		kW	0.03	0.03	0.03							
80	1	m³/s	0.19	0.17	0.15	0.11	0.07	0.04				
		SFP	0.42	0.47	0.54	0.74	1.16	2.00				1.07
		kW	0.08	0.08	0.08	0.08	0.08	0.08				
100	1	m³/s	0.25	0.24	0.23	0.20	0.17	0.13	0.10	0.07	0.04	
		SFP	0.64	0.68	0.72	0.83	0.98	1.29	1.69	2.39	4.03	1.4
		kW	0.16	0.16	0.17	0.17	0.17	0.17	0.17	0.17	0.17	0.16

## Sound Data

Octave Band Frequency SWL

Speed	Test Mode	63	125	250	500	1k	2k	4k	8k	dB(A) @ 3m
25	Breakout	47	45	37	40	37	32	25	31	23
	Inlet	44	48	36	36	32	25	22	29	21
	Outlet	47	49	37	37	33	36	23	30	23
50	Breakout	52	54	54	43	38	41	26	32	29
	Inlet	56	59	56	49	41	34	34	31	31
	Outlet	52	61	54	53	47	46	41	33	34
80	Breakout	62	64	60	58	45	43	32	35	37
	Inlet	55	64	59	64	54	47	42	38	42
	Outlet	62	70	61	69	61	58	55	51	48
100	Breakout	67	69	64	63	51	45	38	40	42
	Inlet	58	70	63	68	62	55	51	49	47
	Outlet	68	75	65	80	67	67	64	60	58

# Performance Guide

## Sentinel 250 Twin Fan

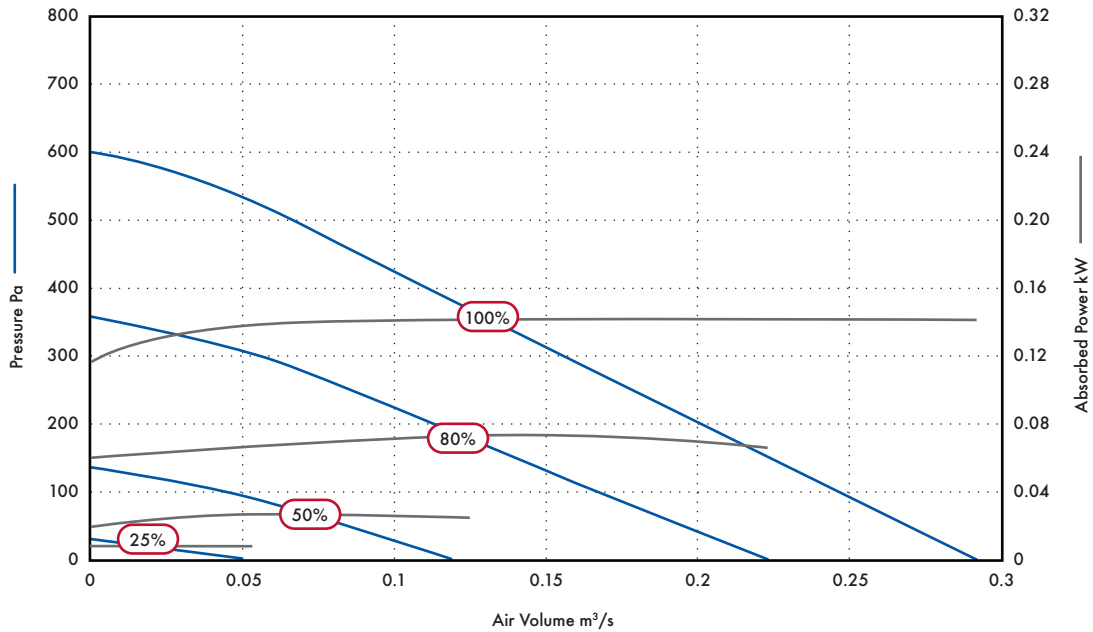

Speed	Motor Phase	Airflow, m <sup>3</sup> /s @ Pa									F.L.C Amps	
		0	50	100	200	300	400	500	600			
25	1	m <sup>3</sup> /s	0.05									0.09
		SFP	0.18									
		kW	0.01									
50	1	m <sup>3</sup> /s	0.12	0.09	0.05							0.2
		SFP	0.21	0.30	0.54							
		kW	0.03	0.03	0.03							
80	1	m <sup>3</sup> /s	0.23	0.20	0.17	0.11	0.06					0.92
		SFP	0.29	0.35	0.43	0.66	1.10					
		kW	0.07	0.07	0.07	0.07	0.07					
100	1	m <sup>3</sup> /s	0.30	0.27	0.25	0.20	0.15	0.11	0.07	0.01		1.4
		SFP	0.47	0.53	0.57	0.69	0.91	1.26	2.01	12.10		
		kW	0.14	0.14	0.14	0.14	0.14	0.14	0.14	0.14	0.12	

## Sound Data

Speed	Test Mode	Octave Band Frequency SWL								dB(A) @ 3m
		63	125	250	500	1k	2k	4k	8k	
25	Breakout	45	41	34	28	26	24	25	31	18
	Inlet	47	41	35	33	27	23	24	31	19
	Outlet	45	42	36	34	32	25	23	30	20
50	Breakout	49	51	50	39	31	28	25	31	25
	Inlet	50	53	51	48	41	33	29	31	29
	Outlet	51	55	49	54	45	43	33	31	33
80	Breakout	56	59	58	51	42	36	30	32	33
	Inlet	59	62	58	62	52	43	42	36	40
	Outlet	58	63	59	67	60	58	53	46	46
100	Breakout	61	64	61	60	49	42	36	35	39
	Inlet	64	68	61	69	60	50	50	47	47
	Outlet	63	69	62	78	66	67	61	57	56

Performance Guide

Sentinel 315 Twin Fan

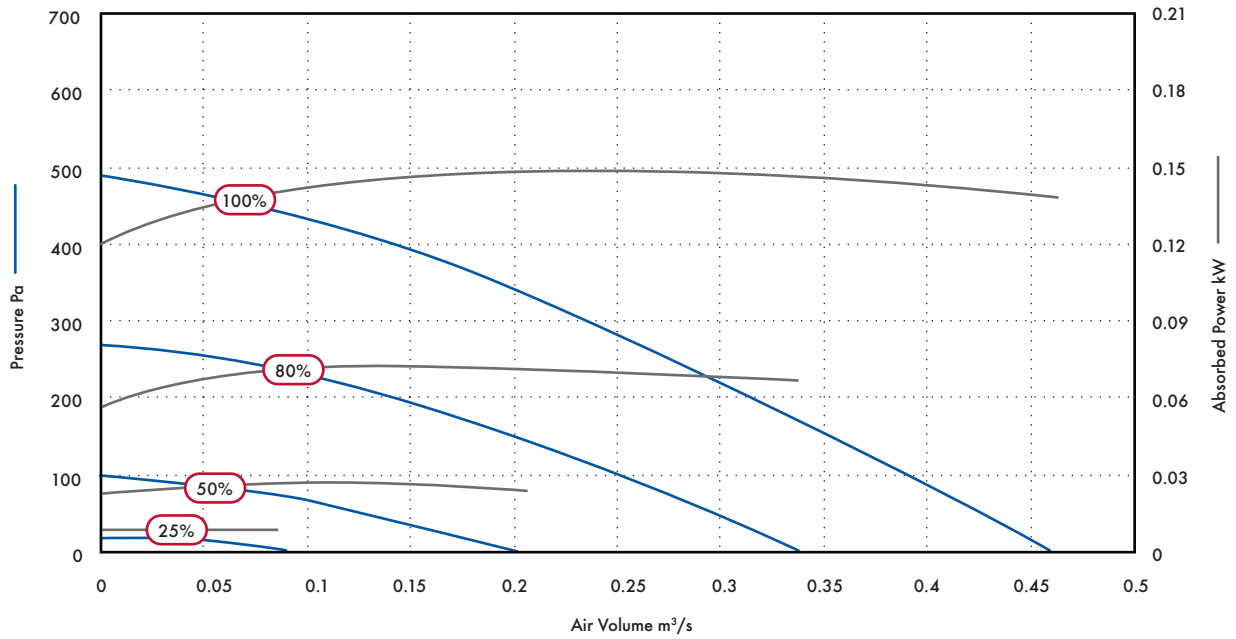

Speed	Motor Phase	Airflow, m³/s @ Pa							F.L.C Amps
		0	50	100	200	300	400		
25	1	m³/s	0.09						0.09
		SFP	0.11						
		kW	0.01						
50	1	m³/s	0.21	0.13	0.01				0.2
		SFP	0.12	0.22	2.40				
		kW	0.03	0.03	0.02				
80	1	m³/s	0.34	0.29	0.25	0.14			0.6
		SFP	0.20	0.23	0.28	0.51			
		kW	0.07	0.07	0.07	0.07			
100	1	m³/s	0.46	0.43	0.39	0.32	0.24	0.14	1.4
		SFP	0.30	0.33	0.36	0.46	0.62	1.04	
		kW	0.14	0.14	0.14	0.15	0.15	0.15	

Sound Data

Speed	Test Mode	Octave Band Frequency SWL								dB(A) @ 3m
		63	125	250	500	1k	2k	4k	8k	
25	Breakout	48	42	37	30	27	25	24	30	19
	Inlet	44	42	34	28	23	22	22	29	17
	Outlet	47	40	35	32	27	24	23	29	18
50	Breakout	57	50	44	42	30	26	25	30	24
	Inlet	53	53	42	40	34	28	24	30	24
	Outlet	54	56	47	58	42	38	29	30	35
80	Breakout	61	66	55	44	37	33	27	30	32
	Inlet	58	72	56	52	45	39	35	32	37
	Outlet	61	79	61	60	55	53	44	40	45
100	Breakout	66	72	71	51	44	38	36	32	43
	Inlet	63	74	65	59	52	46	43	40	42
	Outlet	66	76	68	69	63	61	53	45	49

Performance Guide

Sentinel 400 Twin Fan

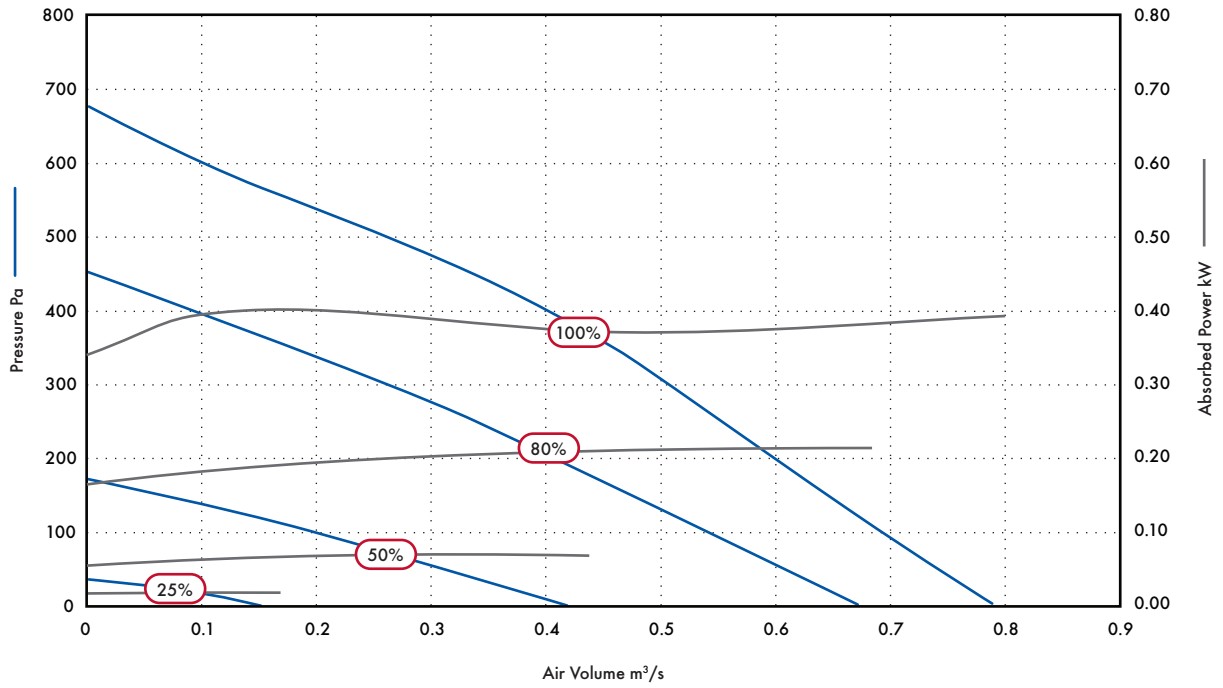

Curve Ref.	Motor Phase	Airflow, m³/s @ Pa										
		0	50	100	200	300	400	500	600	F.L.C Amps		
25	1	m³/s	0.16									
		SFP	0.13								0.19	
		kW	0.02									
50	1	m³/s	0.44	0.34	0.21							
		SFP	0.16	0.21	0.34						0.77	
		kW	0.07	0.07	0.07							
80	1	m³/s	0.69	0.60	0.54	0.43	0.27	0.10				
		SFP	0.31	0.35	0.39	0.50	0.73	1.81			2.02	
		kW	0.21	0.21	0.21	0.22	0.20	0.18				
100	1	m³/s	0.80	0.73	0.68	0.59	0.50	0.40	0.27	0.10		
		SFP	0.49	0.53	0.56	0.63	0.73	0.93	1.46	3.93	2.86	
		kW	0.39	0.39	0.38	0.37	0.36	0.37	0.39	0.39		

Sound Data

Speed	Test Mode	Octave Band Frequency SWL								dB(A) @ 3m
		63	125	250	500	1k	2k	4k	8k	
25	Breakout	56	41	41	31	27	25	24	31	20
	Inlet	46	44	41	35	27	22	23	29	20
	Outlet	48	45	41	38	32	24	24	29	21
50	Breakout	65	62	55	44	38	31	26	30	30
	Inlet	60	66	55	50	46	38	30	31	33
	Outlet	64	67	59	57	53	48	41	35	39
80	Breakout	74	75	68	56	49	43	38	40	42
	Inlet	69	80	67	62	57	50	45	41	46
	Outlet	72	81	72	71	66	62	55	48	52
100	Breakout	78	77	75	61	55	48	46	41	48
	Inlet	73	82	73	66	62	53	50	45	50
	Outlet	75	85	78	77	73	69	63	55	58

Performance Guide

Sentinel 500 Twin Fan

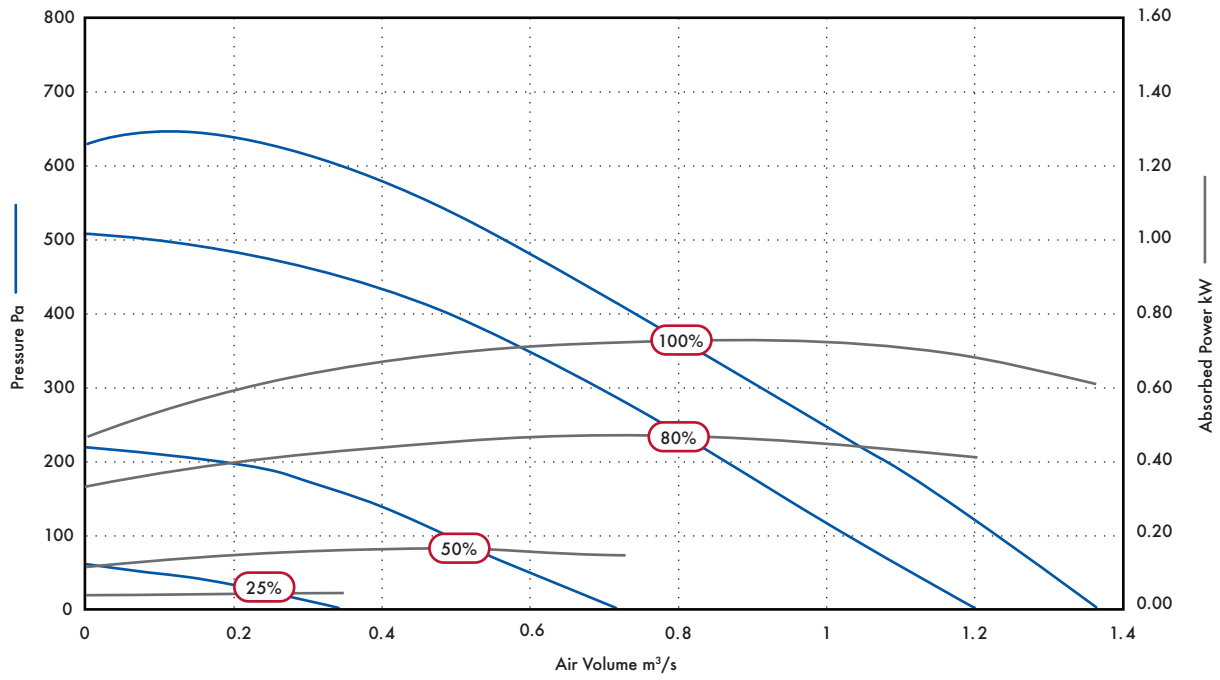

Speed	Motor Phase	Airflow, m³/s @ Pa									
		0	50	100	200	300	400	500	600	F.L.C Amps	
25	3	m³/s	0.36	0.10							0.32
		SFP	0.12	0.40							
		kW	0.04	0.04							
50	3	m³/s	0.73	0.61	0.49	0.20					0.5
		SFP	0.20	0.25	0.33	0.75					
		kW	0.14	0.15	0.16	0.15					
80	3	m³/s	1.20	1.11	1.02	0.86	0.69	0.50	0.08		0.9
		SFP	0.34	0.39	0.44	0.54	0.69	0.92	4.40		
		kW	0.41	0.43	0.44	0.46	0.48	0.46	0.36		
100	3	m³/s	1.37	1.30	1.24	1.09	0.92	0.75	0.57	0.35	1.2
		SFP	0.45	0.49	0.54	0.66	0.79	0.97	1.25	1.88	
		kW	0.61	0.64	0.67	0.71	0.73	0.73	0.71	0.66	

Sound Data

Speed	Test Mode	Octave Band Frequency SWL								dB(A) @ 3m
		63	125	250	500	1k	2k	4k	8k	
25	Breakout	59	45	45	34	29	24	25	30	22
	Inlet	49	45	43	38	33	23	24	31	22
	Outlet	48	42	45	42	37	27	25	31	24
50	Breakout	66	64	54	48	39	32	26	32	32
	Inlet	60	63	58	54	45	40	35	40	35
	Outlet	66	60	64	60	54	51	39	41	41
80	Breakout	72	75	66	59	50	43	37	40	42
	Inlet	67	75	70	65	57	51	47	50	46
	Outlet	75	74	76	73	66	61	53	51	53
100	Breakout	74	79	69	62	54	46	40	41	46
	Inlet	69	80	74	70	61	55	51	51	50
	Outlet	78	78	82	78	70	65	60	54	58



# Sentinel D-Box Sensors & Controls



## Ambient Response Humidity Sensor\*

Humidity Sensor control is fixed at 72 - 75%RH. Incorporates a night time 'set back' function to avoid nuisance tripping as the humidity level rises when the air cools. An integral pullcord provides a manual override function if required. Can be wired for either On/Off or Trickle/Boost operation. Pullcord override and neon indicator. Changeover relay switch. Operating range: 30% - 90%RH. Ambient operating temperature +5°C to +40°C. 24V DC SELV. Dimensions: 87 x 87 x 33mm (H x W x D). Will fit single gang box for surface mounting.



Stock Ref

432945

rings are included to allow setting within a limited temperature range or locking at a fixed set-point. IP20 rated. Sealed sensing mechanism. Mounting direct on surface only. Dimensions: 80 x 104 x 36mm (H x W x D). Volt free switch connection to Sentinel.

Stock Ref

563502B

## Air Quality Sensor (AQS)\*

Automatically reacts to the deterioration of air quality, sensing tobacco smoke, smells and toilet odours to regulate mechanically ventilated areas, such as cinemas, pubs, clubs, restaurants, kitchens, toilets and conference rooms.



The sensor switches when the air quality declines below an adjustable preset level. This is registered by a self-cleaning ceramic sensing head. The air quality sensor should not be used for the detection of combustible gases. Ambient operating temperature range 0°C to +50°C. MIN - MAX mode or direct Damper control. Dimensions: 87 x 157 x 47mm (H x W x D) Surface mounted. 1 - 25 min O/R timer. Supply voltage 24V DC SELV.

Stock Ref

432953

## Ecotronic Humidity Sensor\*

Humidity Control is automatic and can be set to switch between 65 and 90%RH. An integral pullcord provides a manual override function if required. Can be wired for either ON/OFF or Trickle/Boost operation. Set point adjustable. Maximum switching load 1 amp inductive. Pullcord override indicator. Ambient operating temperature 0°C to +40°C. Dimensions: 87 x 87 x 33mm (H x W x D). Supply voltage 24V DC SELV.



Humidity sensors should be sited approx. 100mm below ceiling level and not above cupboards, refer to siting details in fitting and wiring instructions supplied with product.

Stock Ref

432949

## Vent-Axia ThermoSwitch®

Automatically switches on fans on either a rise or fall in air temperature. Can be used for Trickle/ Boost operation on either intake or extract systems. Setting range: +6°C to +30°C. Two internal range limit/locking



## Vent-Axia Visionex PIR\*

A wall or ceiling person presence detector for use with Sentinel. Can be used in MIN - MAX mode or for direct damper control.

Fits any UK single gang mounting box. Adjustable timer overrun (5-25 minutes). Range of detection up to 10 metres. Designed to meet IP43. Ambient operating temperature range 0°C to +50°C. Supply voltage 24V DC SELV.

Stock Ref

433162



\* PLEASE NOTE: These sensors/controls are unique to Sentinel and CANNOT be used with any other product.

## 7 Day TimeSwitch

For applications where regular switching is required at fixed periods or at different times on different days of the week, eg: offices, shops, pubs and restaurants.

The 7 Day TimeSwitch gives twelve On or Off positions per day and can be set for 7 days. The cycle will repeat until changed. Volt free switch connection to Sentinel.



Analogue clock display and integral time switches for ease of setting. Manual override. Removable clear plastic cover protects timeswitch face. Time base: 7 days. Shortest switching time: 2 hours. Ambient operating temperature range -20°C to +85°C. Dimensions: 104 x 74 x 52mm (H x W x D). Supply voltage 220-240V/1/50Hz.

Stock Ref  
**563515A**

## Remote Speed Control\*

Provides infinitely variable Sentinel fan speed control between the 2 set points in Proportional mode. This control does NOT provide an ON/OFF switching facility.

Manual control. Located remotely. 24V DC SELV. Ambient operating temperature -5°C to +40°C. Dimensions: 84 x 84 x 30mm (H x W x D). Will fit single gang box for surface mounting.

Stock Ref

**426332**



## CO<sub>2</sub> Duct Probe

High CO<sub>2</sub> levels promote increased fatigue and reduced concentration. This sensor monitors CO<sub>2</sub> levels in extract ducts from conference areas, offices, theatres etc. With Sentinel in Proportional control mode, air extraction rate tracks the CO<sub>2</sub> level to improve indoor air quality.

24V DC SELV. 0 - 2000ppm CO<sub>2</sub> working range. Auto-calibrating NDIR absorption sensor. Stable drift compensation. Adjustable probe length. MAX. IP Rating 65.

Stock Ref

**433259**



## Remote Fan Status Indicator\*

This remote display unit will indicate the running status and condition of the fan or fans. Can be used in all Sentinel operating modes for fan mounting.

24V DC SELV. Directly connects into the SCU. Used for single and twin fan mounting. Ambient operating temperature -5°C to +50°C. Dimensions: 86 x 86 x 28mm (H x W x D).

Stock Ref

**433816**



## Constant Pressure System Accessories PIR Grille\*

PIR grille is an extract grille with an integral flap damper. Suitable for bathrooms and WC's. The PIR function fully opens the damper when a person is detected. The opening time is fixed at 20 mins. Spigot size is 125mm.

12V AC SELV unit using the main transformer unit supplied. Integral PIR person presence sensor controlling damper. Auto-humidity control damper response at all times. 100° viewing angle. Temperature range 0 - 50°C. Size: 158 x 150 x 35mm (H x W x D). MAX airflow 70m<sup>3</sup>/hr @100 Pa.

Stock Ref

**434184**



## Dampers\*

Two types available:

- MM type - Opens from a Closed / Minimum Flow position to a Fully Open / Maximum Flow position controlled by switching sensors.
- PC type - opening proportionally when controlled by sensors.

Duct sizes available: 100, 125, 150, 200, 250 and 315. Industry standard actuators.

Typical ordering designation: DVD size MM or PC



## Power Supply\*

For those situations where a separate 24V DC SELV supply source is required. 24W output capacity. See Fitting & Wiring instructions for connection details.

Stock Ref

**433193**



# Sentinel Apex

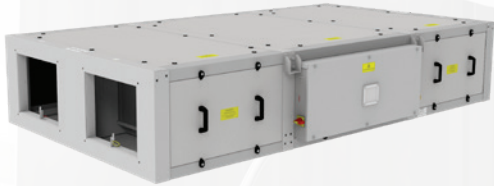

Vent-Axia's Sentinel Apex range of commercial heat recovery units with up to 93% EN308 heat recovery efficiency, low sound levels and low specific fan powers the range provides high levels of performance efficiently. A new advanced control system that provides on board control, in room control and App based control full functionality commissioning and monitoring is simply provided. This control can be coupled with Vent-Axia's new range of sensors with wired or wireless communication providing close control of, and monitoring of your indoor air quality. Sensors include CO<sub>2</sub>, humidity and temperature and provide both proportional and switch control.

**Vent-Axia**<sup>®</sup>





Sentinel Apex HR06

N3-N6

---



Sentinel Apex HR10

N7-N10

---



Sentinel Apex HR15

N11-N14

---



Sentinel Apex HR21

N15-N18

---



# Sentinel Apex HR06

- Very low sound levels independently tested and verified by SRL
- Low SFP utilising IE 5 equivalent motors
- High Heat Recovery Efficiency – up to 93% (EN308)
- Automatic summer bypass sized to eliminate performance loss
- ePM10 50% and ePM1 50% filters as standard (M5 / F7 equivalent)
- Filter access from bottom and side as standard
- Digital on board controller and remote room controller as standard
- App connectivity as standard
- Wired and Wireless communication sensors available
- Integral condensate tray and pump
- Electric frost protection heater as standard

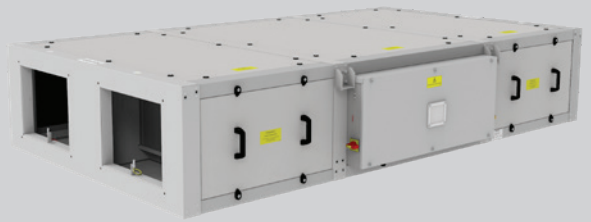

## Performance simply delivered with more as standard

Vent-Axia's Sentinel Apex range of commercial heat recovery units with up to 93% EN308 heat recovery efficiency, low sound levels and low specific fan powers the range provides high levels of performance efficiently. A new advanced control system that provides on board control, in room control and App based control full functionality commissioning and monitoring is simply provided. This control can be coupled with Vent-Axia's new range of sensors with wired or wireless communication providing close control of, and monitoring of your indoor air quality. Sensors include CO<sub>2</sub>, humidity and temperature and provide both proportional and switch control.

The Sentinel Apex HR06 unit is manufactured with a double skinned pentapost construction incorporating aluzinc frames and panels. The panels are acoustically and thermally treated with 90kg/m<sup>3</sup> high efficiency acoustic and thermally insulating foam (fire retardant to BS476 Part 7 Class 1 & Part 6 Class O). The construction of the unit, IPX4, allows for internal and external mounting as standard, however, the roof assembly should be included for full external locations.

The housing is designed to be as compact as possible for concealed false ceiling applications with top and bottom access panels for maintenance. Access panels are sized to enable single person maintenance.

The fans utilised in the Sentinel Apex HR06 are the latest EC/DC external rotor motors specifically chosen for their low power consumption and low noise characteristics. The assembly is dynamically balanced to DIN ISO 1940 Grade 6.3. Ball bearings are greased for life. Insulation is Class 'B' (from -25°C to +60°C). All models incorporate internal electronic overload protection and a soft start function.

The Sentinel Apex HR06 is complete as standard with ISO ePM10 50% (M5) extract filter and ISO ePM1 50% (F7) supply, complete with a filter change warning. Filters have been selected to fully comply with the requirements of ISO16890 whilst having low pressure loss characteristics.

An integral electric frost heater is included to provide frost protection of the cell and filters down to -10°C.

The unit is complete with an integral summer bypass facility which has been designed to provide full bypass without impact to the airflow or

power consumption of the unit whilst in bypass mode.

Airflow and power consumption tested in accordance with BS EN 5801. Sound data derived from independent testing at Sound Research Laboratories in accordance with EN ISO 3741:2010. Published dB(A) figures are free field sound pressure levels at 3m with spherical propagation at a reference level of 2 x 10<sup>-5</sup> Pa. The inlet/outlet sound power level spectra figures are dB with a reference of 10<sup>-12</sup> watts.

An integral condensate tray is fitted along with an internal quiet running high quality pump allowing for removal of the condensate via a 10mm condensate pipe.

To facilitate normal access and maintenance to the unit there are both side and bottom access panels as standard. Should it be required, all panels are removable allowing access and removal of the heat recovery cell and all other components. A lockable isolator is fitted to the control panel preventing accidental operation whilst any maintenance is being carried out.

The electrical supply for the unit is 230V +/- 10% / 50/60Hz / 1ph. A 24V DC power is available from the unit for powering any of the matched sensors and switches.

The Sentinel Apex HR06 unit is fitted with an integrated control system as standard with a purpose designed user interface controller incorporating an alphanumeric 2 line display with 4 button keypad for fan status and a basic commissioning setup mounted within the control panel. A remote HMI is also included for that can be mounted within the room that is being ventilated. This allows for local monitoring of the unit along with the commissioning set-up.

App based control is also available via the Vent-Axia Connect App. This provides detailed commissioning and monitoring information and the ability to control the unit remotely.

A full range of sensors is available including humidity, temperature and CO<sub>2</sub> monitoring. These sensors are available for both wired and wireless communication with the wireless sensors being either local mains or battery powered.

Dimensions (mm)

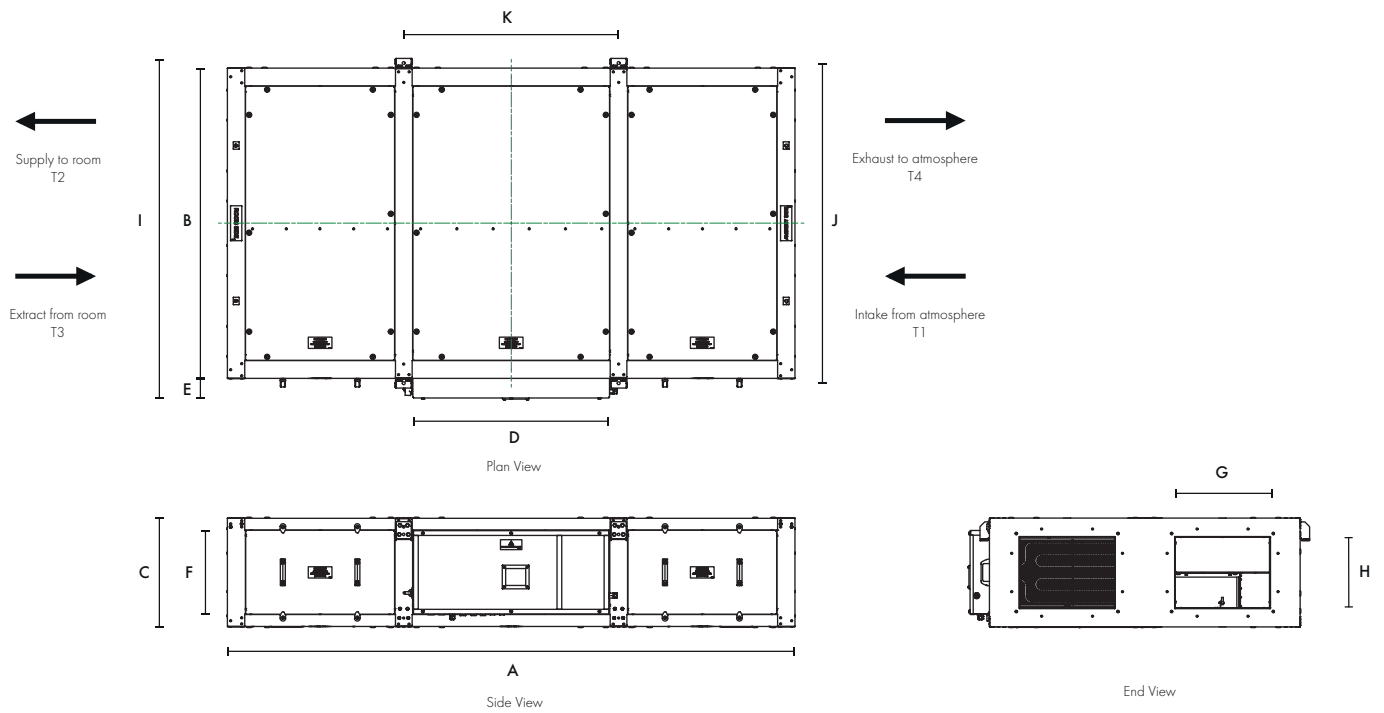

A (LENGTH)	B (WIDTH)	C (HEIGHT)	D	E	F	G	H	I	J	K	kg
2141	1323	350	719	89	248	400	200	1450	1363	791	275

Heat Recovery Efficiency

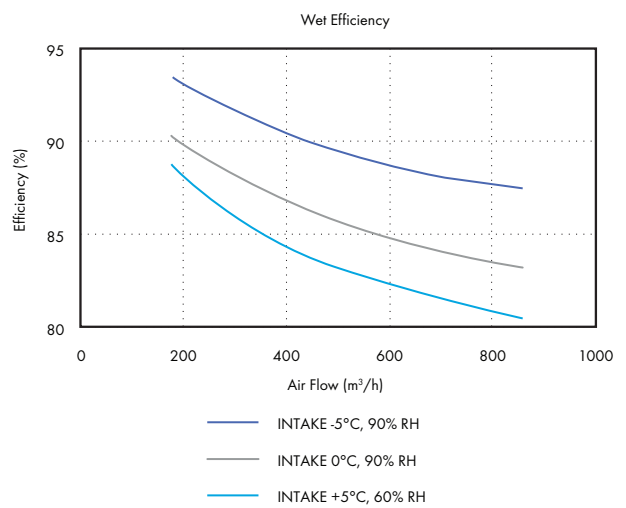
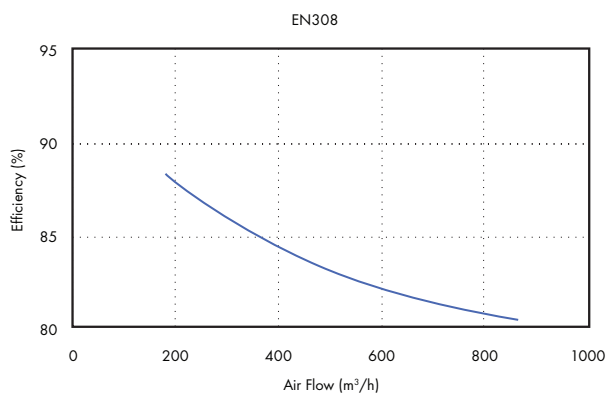

## Performance Guide - Sentinel Apex HR06

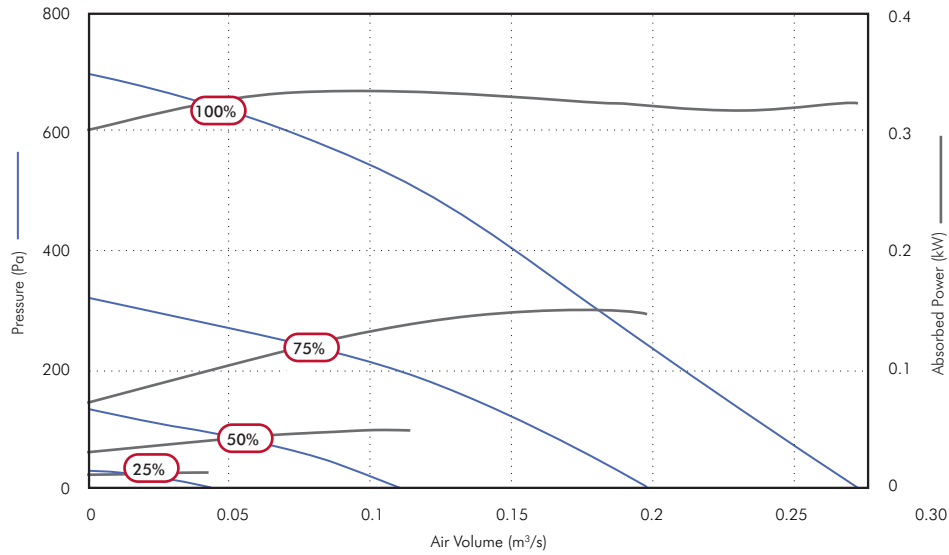

Speed	Airflow, m³/s @ Pa										Fans F.L.C.	Supply Voltage	Frost Heater	Unit Rated Current	
	0	25	50	100	150	200	250	300	400	500					
100%	m³/s	0.27	0.27	0.26	0.24	0.22	0.21	0.19	0.18	0.15	0.12	1.5A	230/1/50	2.4kW	12A
	SFP	1.19	1.21	1.25	1.34	1.42	1.51	1.67	1.82	2.19	2.78				
	kW	0.323	0.320	0.320	0.318	0.318	0.318	0.320	0.323	0.334	0.334				
75%	m³/s	0.20	0.19	0.18	0.16	0.13	0.11	0.07							
	SFP	0.73	0.77	0.84	0.93	1.07	1.23	1.66							
	kW	0.144	0.145	0.147	0.147	0.143	0.132	0.116							
50%	m³/s	0.11	0.10	0.08	0.04										
	SFP	0.41	0.47	0.55	0.95										
	kW	0.045	0.045	0.044	0.036										
25%	m³/s	0.04	0.01												
	SFP	0.012	0.27												
	kW	0.011	1.06												

## Sound Data - Sentinel Apex HR06

Speed	Test Mode	63	125	250	500	1k	2k	4k	8k	Sound Pressure level @ 3.0m dBA
100%	Breakout	58	54	56	48	46	43	35	29	32
	Exhaust T4	58	55	61	54	54	54	46	36	
	Extract T3	64	64	72	64	56	56	55	48	
	Intake T1	64	64	71	63	57	56	55	48	
	Supply T2	58	54	59	53	53	54	46	36	
75%	Breakout	53	52	54	40	39	36	29	23	27
	Exhaust T4	52	50	52	47	46	47	39	28	
	Extract T3	60	59	68	54	48	48	47	40	
	Intake T1	59	59	67	55	50	49	47	39	
	Supply T2	52	50	54	46	47	48	39	28	
50%	Breakout	46	51	38	30	28	26	25	21	17
	Exhaust T4	45	55	41	36	35	35	26	23	
	Extract T3	53	64	53	44	37	36	34	26	
	Intake T1	54	68	53	44	39	37	34	26	
	Supply T2	45	49	41	35	35	36	26	24	
25%	Breakout	40	35	30	17	19	16	22	21	9
	Exhaust T4	38	32	27	21	19	17	18	23	
	Extract T3	44	43	35	28	20	18	19	23	
	Intake T1	44	40	35	27	21	18	18	23	
	Supply T2	37	32	27	21	19	18	19	24	

For full sound and performance data please use our Fan Selection Program [www.vent-axia.com/fanselector/product/apex](http://www.vent-axia.com/fanselector/product/apex)

Sound data derived from independent testing at Sound Research Laboratories in accordance with EN ISO 3741:2010. Published dB(A) figures are free field sound pressure levels at 3m with spherical propagation at a reference level of  $2 \times 10^{-5}$  Pa. The inlet/outlet sound power level spectra figures are dB with a reference of  $10^{-12}$  watts.

## Accessories

### Attenuator



Single skinned attenuators purpose designed for the Apex Heat Recovery range to minimise in duct noise. Attenuators are supplied in standard lengths of 900mm, 1200mm and 1500mm, constructed from Galvanised steel with profiled perforated sheet internal, mineral wool sound absorbing material and 30mm profiled flanges for duct and unit mounting. Data has been obtained by testing in accordance with BS EN ISO7235:2009.

Stock Ref.	Dimensions (mm)			kg	Insertion Loss dB								m <sup>3</sup> /hr @ Pa		
	Length	Width	Height		63	125	250	500	1k	2k	4k	8k	300	600	1000
ATT900-HR06	900	400	200	17	2	5	11	19	33	39	31	24	8	30	83
ATT1200-HR06	1200	400	200	21	3	6	14	26	43	45	35	27	8	33	92
ATT1500-HR06	1500	400	200	31	4	7	18	32	52	52	38	30	9	37	103

### Duct mounted Heating / Cooling



Rectangular duct mounted heater battery with either electric heating complete with integral thyristor controls, or LPHW water heating, each designed to provide approximately 10°C temperature rise. Chilled water cooler also available with integral condensate tray. Note waterside controls are not included.

Stock Ref.	Type	Dimensions (mm)			kg	Heater rating kW	Electrical supply	Water Temp			m <sup>3</sup> /hr @ Pa		
		Length	Width	Height				Flow	Return	Connection	300	600	1000
EHB-HR06	HR 6 Duct mounted Rectangular electric heater with controls	300	400	200	5	2.00	230/1/50	N/A	N/A	N/A	8	33	92
HWB-HR06	HR 6 Duct mounted Rectangular LPHW heating battery	200	400	200	5	2.01	N/A	80°C	60°C	1/2"	8	33	92
CWB-HR06	HR 6 Duct mounted Rectangular water cooling battery	200	400	200	5	2.52	N/A	6°C	12°C	3/4"	8	33	92

### Roof Assembly

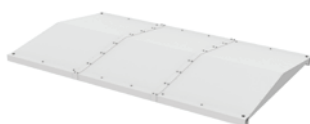

Pitched roof for external mounting, supplied separate for fitting on site.

Stock Ref	Length mm	Width mm	Height mm	Weight kg
WRF-HR06	2141	1455	95	48

### Intake / Exhaust Cowl



Weather inlet/discharge cowl for external mounting (one required for each airstream).

Stock Ref	Length mm	Width mm	Height mm	Weight kg
497218	294	402	274	4

### Transformation Piece



Rectangular to round transformation piece designed to fix directly to the unit or any of the specific HR06 duct accessories to enable connection to 250mm round ducting.

Stock Ref	Length mm	Width mm	Height mm	Weight kg
497222	250	400	200	3

### Flexible Connection



Stock Ref	Length mm	Width mm	Height mm	Weight kg
497018	130	400	200	3



# Sentinel Apex HR10

- Very low sound levels independently tested and verified by SRL
- Low SFP utilising IE 5 equivalent motors
- High Heat Recovery Efficiency – up to 93% (EN308)
- Automatic summer bypass sized to eliminate performance loss
- ePM10 50% and ePM1 50% filters as standard (M5 / F7 equivalent)
- Filter access from bottom and side as standard
- Digital on board controller and remote room controller as standard
- App connectivity as standard
- Wired and Wireless communication sensors available
- Integral condensate tray and pump
- Electric frost protection heater as standard

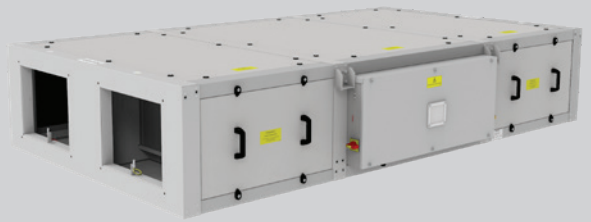

## Performance simply delivered with more as standard

Vent-Axia's Sentinel Apex range of commercial heat recovery units with up to 93% EN308 heat recovery efficiency, low sound levels and low specific fan powers the range provides high levels of performance efficiently. A new advanced control system that provides on board control, in room control and App based control full functionality commissioning and monitoring is simply provided. This control can be coupled with Vent-Axia's new range of sensors with wired or wireless communication providing close control of, and monitoring of your indoor air quality. Sensors include CO<sub>2</sub>, humidity and temperature and provide both proportional and switch control.

The Sentinel Apex HR10 unit is manufactured with a double skinned pentapost construction incorporating aluzinc frames and panels. The panels are acoustically and thermally treated with 90kg/m<sup>3</sup> high efficiency acoustic and thermally insulating foam (fire retardant to BS476 Part 7 Class 1 & Part 6 Class O). The construction of the unit, IPX4, allows for internal and external mounting as standard, however, the roof assembly should be included for full external locations.

The housing is designed to be as compact as possible for concealed false ceiling applications with top and bottom access panels for maintenance. Access panels are sized to enable single person maintenance.

The fans utilised in the Sentinel Apex HR10 are the latest EC/DC external rotor motors specifically chosen for their low power consumption and low noise characteristics. The assembly is dynamically balanced to DIN ISO 1940 Grade 6.3. Ball bearings are greased for life. Insulation is Class 'B' (from -25°C to +60°C). All models incorporate internal electronic overload protection and a soft start function.

The Sentinel Apex HR10 is complete as standard with ISO ePM10 50% (M5) extract filter and ISO ePM1 50% (F7) supply, complete with a filter change warning. Filters have been selected to fully comply with the requirements of ISO16890 whilst having low pressure loss characteristics.

An integral electric frost heater is included to provide frost protection of the cell and filters down to -10°C.

The unit is complete with an integral summer bypass facility which has been designed to provide full bypass without impact to the airflow or

power consumption of the unit whilst in bypass mode.

Airflow and power consumption tested in accordance with BS EN 5801. Sound data derived from independent testing at Sound Research Laboratories in accordance with EN ISO 3741:2010. Published dB(A) figures are free field sound pressure levels at 3m with spherical propagation at a reference level of 2 x 10<sup>-5</sup> Pa. The inlet/outlet sound power level spectra figures are dB with a reference of 10<sup>-12</sup> watts.

An integral condensate tray is fitted along with an internal quiet running high quality pump allowing for removal of the condensate via a 10mm condensate pipe.

To facilitate normal access and maintenance to the unit there are both side and bottom access panels as standard. Should it be required, all panels are removable allowing access and removal of the heat recovery cell and all other components. A lockable isolator is fitted to the control panel preventing accidental operation whilst any maintenance is being carried out.

The electrical supply for the unit is 230V +/- 10% / 50/60Hz / 1ph. A 24V DC power is available from the unit for powering any of the matched sensors and switches.

The Sentinel Apex HR10 unit is fitted with an integrated control system as standard with a purpose designed user interface controller incorporating an alphanumeric 2 line display with 4 button keypad for fan status and a basic commissioning setup mounted within the control panel. A remote HMI is also included for that can be mounted within the room that is being ventilated. This allows for local monitoring of the unit along with the commissioning set-up.

App based control is also available via the Vent-Axia Connect App. This provides detailed commissioning and monitoring information and the ability to control the unit remotely.

A full range of sensors is available including humidity, temperature and CO<sub>2</sub> monitoring. These sensors are available for both wired and wireless communication with the wireless sensors being either local mains or battery powered.

Dimensions (mm)

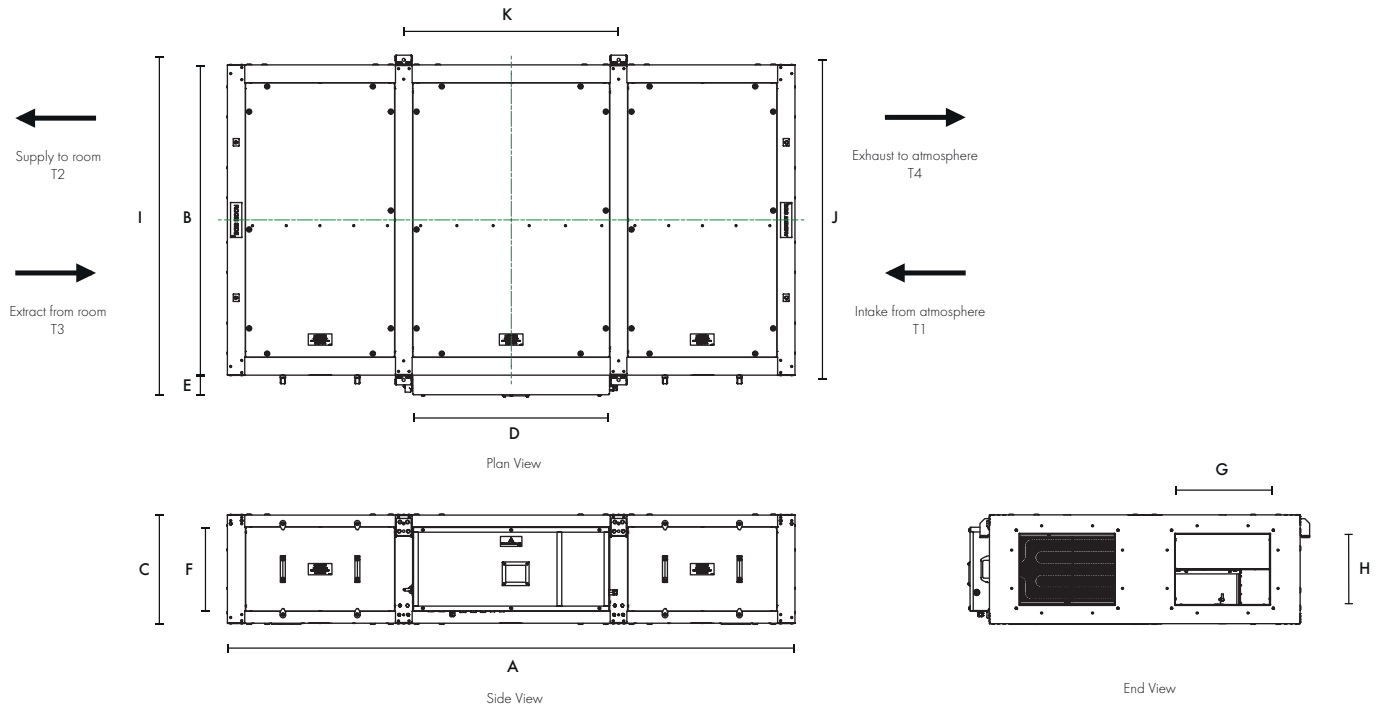

A (LENGTH)	B (WIDTH)	C (HEIGHT)	D	E	F	G	H	I	J	K	kg
2400	1312	460	831	88	356	400	300	1440	1353	908	338

Heat Recovery Efficiency

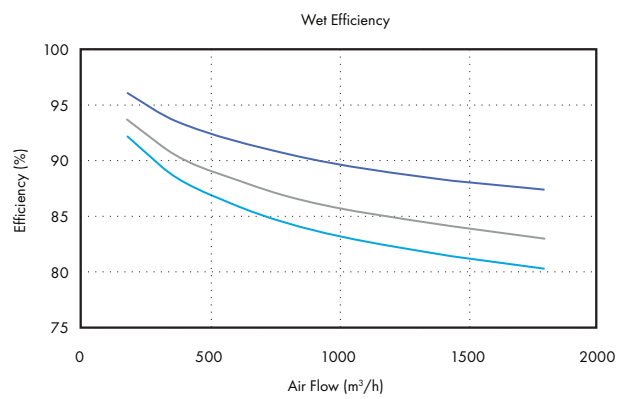
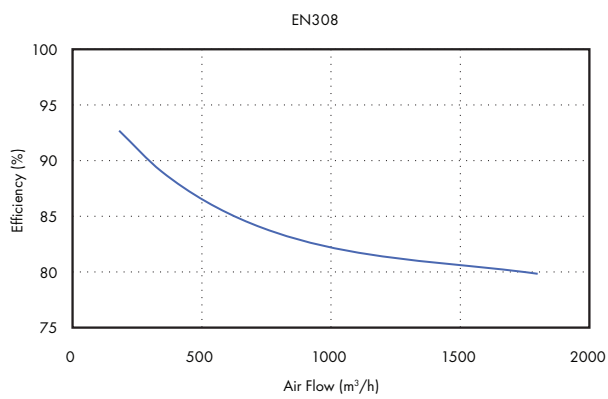

- INTAKE -5°C, 90% RH
- INTAKE 0°C, 90% RH
- INTAKE +5°C, 60% RH

## Performance Guide - Sentinel Apex HR10

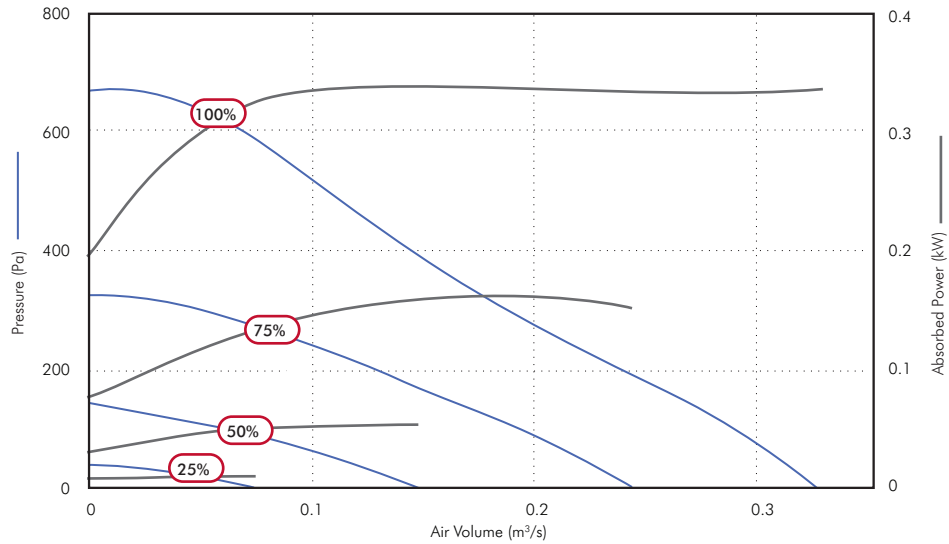

Speed	Airflow, m <sup>3</sup> /s @ Pa											Fans F.L.C.	Supply Voltage	Frost Heater	Unit Rated Current	
	0	25	50	100	150	200	250	300	400	500						
100%	m <sup>3</sup> /s	0.33	0.32	0.31	0.29	0.26	0.24	0.21	0.18	0.15	0.10	1.5A	230/1/50	2.8kW	14A	
	SFP	1.03	1.05	1.08	1.17	1.28	1.40	1.61	1.87	2.32	3.24					
	kW	0.337	0.337	0.337	0.334	0.333	0.333	0.335	0.337	0.337	0.338					
75%	m <sup>3</sup> /s	0.24	0.23	0.22	0.19	0.15	0.13	0.09								
	SFP	0.62	0.67	0.74	0.84	1.03	1.22	1.55								
	kW	0.151	0.155	0.160	0.160	0.160	0.153	0.138								
50%	m <sup>3</sup> /s	0.15	0.13	0.11	0.06											
	SFP	0.34	0.37	0.47	0.79											
	kW	0.050	0.050	0.051	0.046											
25%	m <sup>3</sup> /s	0.07	0.03													
	SFP	0.08	0.21													
	kW	0.006	0.006													

## Sound Data - Sentinel Apex HR10

Speed	Test Mode	63	125	250	500	1k	2k	4k	8k	Sound Pressure level @ 3.0m dBA
100%	Breakout	57	53	55	47	42	40	36	26	30
	Exhaust T4	55	57	63	54	56	52	42	33	
	Extract T3	58	59	71	61	59	59	56	51	
	Intake T1	58	58	68	58	60	59	56	51	
	Supply T2	51	49	61	54	54	51	42	34	
75%	Breakout	51	48	48	44	35	33	25	21	24
	Exhaust T4	50	53	54	51	48	45	33	25	
	Extract T3	53	56	52	56	54	51	48	41	
	Intake T1	53	56	61	51	54	51	47	39	
	Supply T2	46	46	53	48	46	44	33	25	
50%	Breakout	45	44	35	33	24	23	18	21	14
	Exhaust T4	44	49	39	38	38	35	22	23	
	Extract T3	48	54	50	44	42	41	36	25	
	Intake T1	47	52	51	42	42	40	34	25	
	Supply T2	40	43	38	37	37	34	22	23	
25%	Breakout	36	31	27	18	14	15	17	21	6
	Exhaust T4	36	30	24	20	19	17	18	23	
	Extract T3	40	37	34	26	23	19	19	22	
	Intake T1	40	34	32	23	20	17	19	23	
	Supply T2	31	27	24	20	17	15	18	23	

For full sound and performance data please use our Fan Selection Program [www.vent-axia.com/fanselector/product/apex](http://www.vent-axia.com/fanselector/product/apex)

Sound data derived from independent testing at Sound Research Laboratories in accordance with EN ISO 3741:2010. Published dB(A) figures are free field sound pressure levels at 3m with spherical propagation at a reference level of  $2 \times 10^{-5}$  Pa. The inlet/outlet sound power level spectra figures are dB with a reference of  $10^{-12}$  watts.

## Accessories

### Attenuator



Single skinned attenuators purpose designed for the Apex Heat Recovery range to minimise in duct noise. Attenuators are supplied in standard lengths of 900mm, 1200mm and 1500mm, constructed from Galvanised steel with profiled perforated sheet internal, mineral wool sound absorbing material and 30mm profiled flanges for duct and unit mounting. Data has been obtained by testing in accordance with BS EN ISO7235:2009.

Stock Ref.	Dimensions (mm)			kg Weight	Insertion Loss dB								m <sup>3</sup> /hr @ Pa				
	Length	Width	Height		63	125	250	500	1k	2k	4k	8k	300	600	1000	1500	2000
ATT900-HR10	900	400	300	18	2	3	8	15	27	21	14	10	1	3	8	17	30
ATT1200-HR10	1200	400	300	23	2	4	10	19	36	24	16	12	1	3	8	18	32
ATT1500-HR10	1500	400	300	34	2	5	12	24	44	28	19	14	1	3	9	20	36

### Duct mounted Heating / Cooling



Rectangular duct mounted heater battery with either electric heating complete with integral thyristor controls, or LPHW water heating, each designed to provide approximately 10°C temperature rise. Chilled water cooler also available with integral condensate tray. Note waterside controls are not included.

Stock Ref.	Type	Dimensions (mm)			kg Weight	Heater rating kW	Electrical supply	Water Temp			m <sup>3</sup> /hr @ Pa				
		Length	Width	Height				Flow	Return	Connection	300	600	1000	1500	2000
EHB-HR10	HR 10 Duct mounted Rectangular electric heater with controls	300	400	300	6	4.00	230/1/50	N/A	N/A	N/A	1	3	8	18	32
HWB-HR10	HR 10 Duct mounted Rectangular LPHW heating battery	200	400	300	7	3.35	N/A	80°C	60°C	1/2"	1	3	8	18	32
CWB-HR10	HR 10 Duct mounted Rectangular water cooling battery	200	500	300	7	4.13	N/A	6°C	12°C	3/4"	1	3	8	18	32

### Roof Assembly

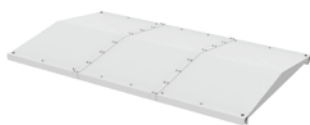

Stock Ref	Length mm	Width mm	Height mm	Weight kg
WRF-HR10	2400	1455	95	52

### Intake / Exhaust Cowl



Weather inlet/discharge cowl for external mounting (one required for each airstream).

Stock Ref	Length mm	Width mm	Height mm	Weight kg
497219	394	402	380	6

### Transformation Piece



Rectangular to round transformation piece designed to fix directly to the unit or any of the specific HR10 duct accessories to enable connection to 315mm round ducting.

Stock Ref	Length mm	Width mm	Height mm	Weight kg
497223	325	400	300	4

### Flexible Connection



Stock Ref	Length mm	Width mm	Height mm	Weight kg
497019	130	400	300	4

# Sentinel Apex HR15

- Very low sound levels independently tested and verified by SRL
- Low SFP utilising IE 5 equivalent motors
- High Heat Recovery Efficiency – up to 93% (EN308)
- Automatic summer bypass sized to eliminate performance loss
- ePM10 50% and ePM1 50% filters as standard (M5 / F7 equivalent)
- Filter access from bottom and side as standard
- Digital on board controller and remote room controller as standard
- App connectivity as standard
- Wired and Wireless communication sensors available
- Integral condensate tray and pump
- Electric frost protection heater as standard

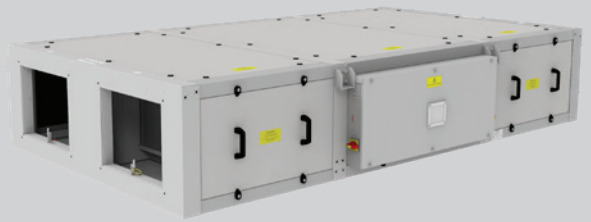

## Performance simply delivered with more as standard

Vent-Axia's Sentinel Apex range of commercial heat recovery units with up to 93% EN308 heat recovery efficiency, low sound levels and low specific fan powers the range provides high levels of performance efficiently. A new advanced control system that provides on board control, in room control and App based control full functionality commissioning and monitoring is simply provided. This control can be coupled with Vent-Axia's new range of sensors with wired or wireless communication providing close control of, and monitoring of your indoor air quality. Sensors include CO<sub>2</sub>, humidity and temperature and provide both proportional and switch control.

The Sentinel Apex HR15 unit is manufactured with a double skinned pentapost construction incorporating aluzinc frames and panels. The panels are acoustically and thermally treated with 90kg/m<sup>3</sup> high efficiency acoustic and thermally insulating foam (fire retardant to BS476 Part 7 Class 1 & Part 6 Class O). The construction of the unit, IPX4, allows for internal and external mounting as standard, however, the roof assembly should be included for full external locations.

The housing is designed to be as compact as possible for concealed false ceiling applications with top and bottom access panels for maintenance. Access panels are sized to enable single person maintenance.

The fans utilised in the Sentinel Apex HR15 are the latest EC/DC external rotor motors specifically chosen for their low power consumption and low noise characteristics. The assembly is dynamically balanced to DIN ISO 1940 Grade 6.3. Ball bearings are greased for life. Insulation is Class 'B' (from -25°C to +60°C). All models incorporate internal electronic overload protection and a soft start function.

The Sentinel Apex HR15 is complete as standard with ISO ePM10 50% (M5) extract filter and ISO ePM1 50% (F7) supply, complete with a filter change warning. Filters have been selected to fully comply with the requirements of ISO16890 whilst having low pressure loss characteristics.

An integral electric frost heater is included to provide frost protection of the cell and filters down to -10°C.

The unit is complete with an integral summer bypass facility which has been designed to provide full bypass without impact to the airflow or

power consumption of the unit whilst in bypass mode.

Airflow and power consumption tested in accordance with BS EN 5801. Sound data derived from independent testing at Sound Research Laboratories in accordance with EN ISO 3741:2010. Published dB(A) figures are free field sound pressure levels at 3m with spherical propagation at a reference level of 2 x 10<sup>-5</sup> Pa. The inlet/outlet sound power level spectra figures are dB with a reference of 10<sup>-12</sup> watts.

An integral condensate tray is fitted along with an internal quiet running high quality pump allowing for removal of the condensate via a 10mm condensate pipe.

To facilitate normal access and maintenance to the unit there are both side and bottom access panels as standard. Should it be required, all panels are removable allowing access and removal of the heat recovery cell and all other components. A lockable isolator is fitted to the control panel preventing accidental operation whilst any maintenance is being carried out.

The electrical supply for the unit is 230V +/- 10% / 50/60Hz / 1ph. A 24V DC power is available from the unit for powering any of the matched sensors and switches.

The Sentinel Apex HR15 unit is fitted with an integrated control system as standard with a purpose designed user interface controller incorporating an alphanumeric 2 line display with 4 button keypad for fan status and a basic commissioning setup mounted within the control panel. A remote HMI is also included for that can be mounted within the room that is being ventilated. This allows for local monitoring of the unit along with the commissioning set-up.

App based control is also available via the Vent-Axia Connect App. This provides detailed commissioning and monitoring information and the ability to control the unit remotely.

A full range of sensors is available including humidity, temperature and CO<sub>2</sub> monitoring. These sensors are available for both wired and wireless communication with the wireless sensors being either local mains or battery powered.

Dimensions (mm)

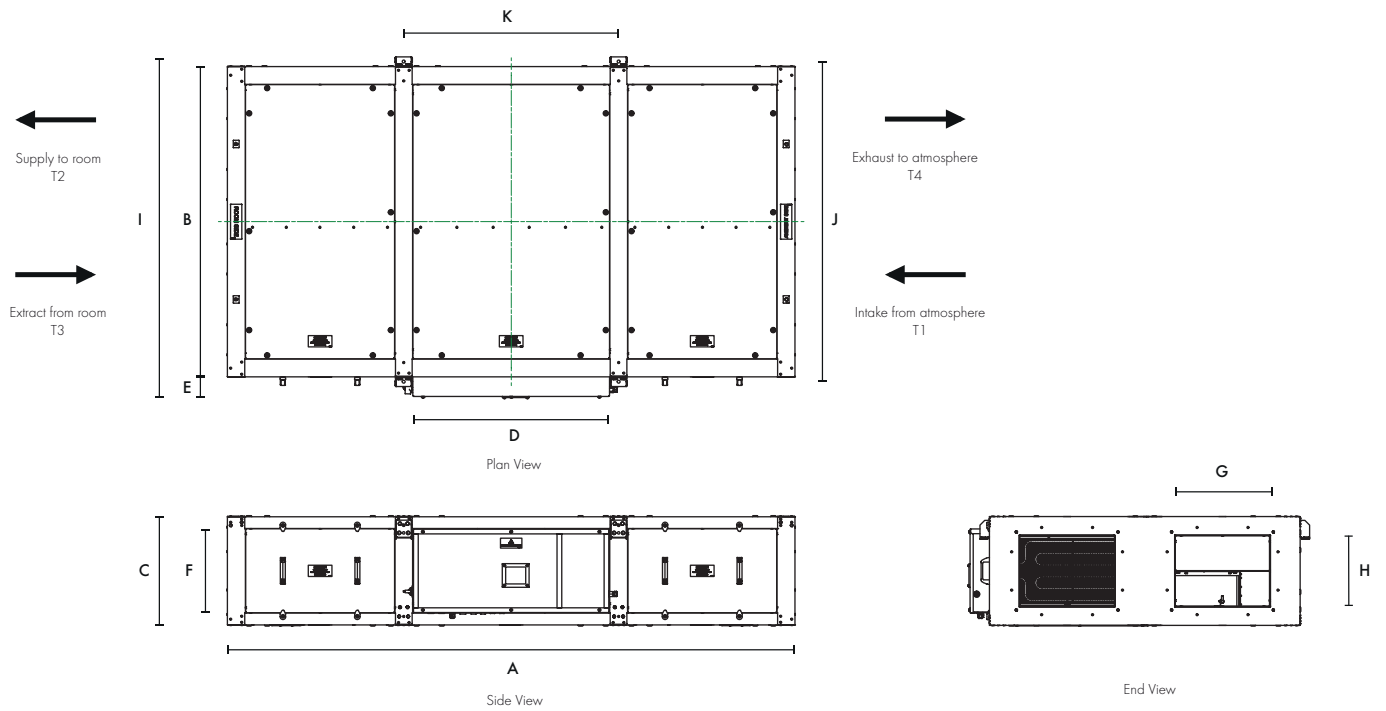

A (LENGTH)	B (WIDTH)	C (HEIGHT)	D	E	F	G	H	I	J	K	kg
2400	1312	460	831	88	356	400	300	1440	1353	908	348

Heat Recovery Efficiency

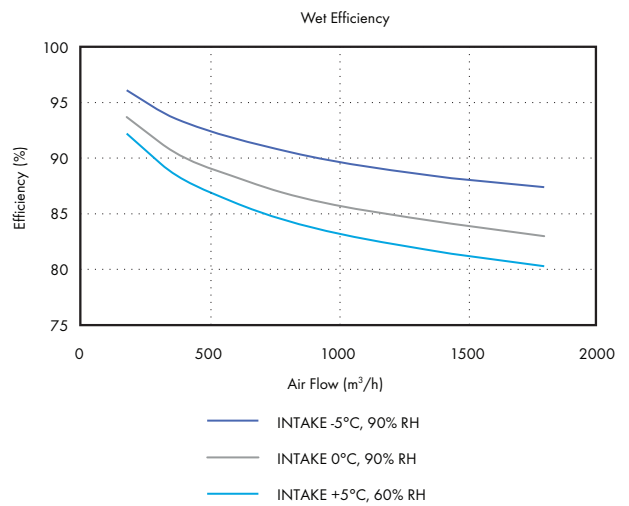
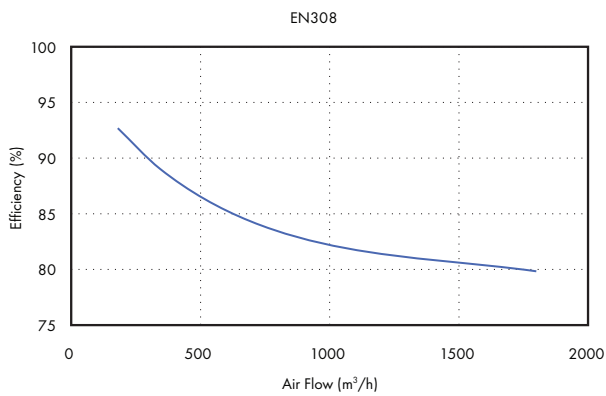

## Performance Guide - Sentinel Apex HR15

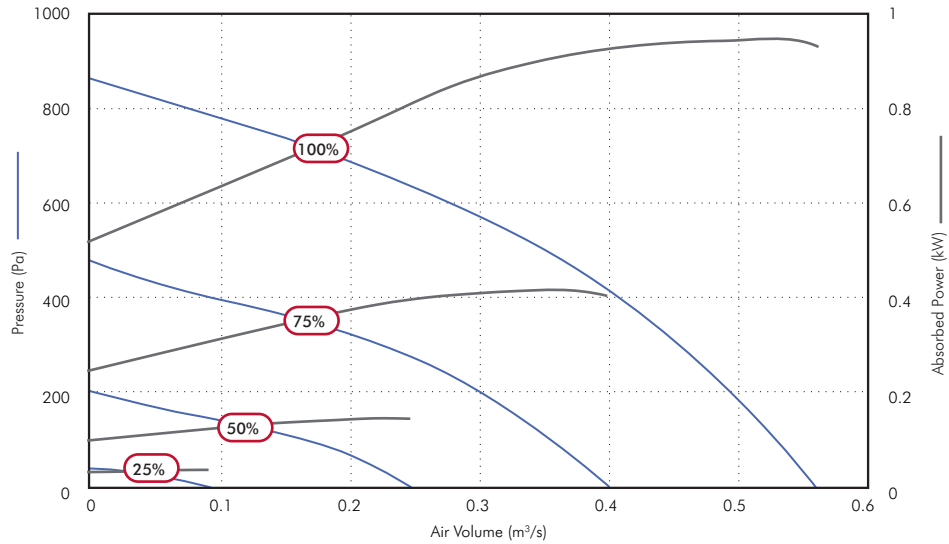

Speed	Airflow, m³/s @ Pa									Fans F.L.C.	Supply Voltage	Frost Heater	Unit Rated Current
	0	25	50	100	150	200	300	400					
100%	m³/s	0.56	0.55	0.54	0.52	0.50	0.49	0.45	0.40	5.0A	230/1/50	5.6kW	29.0A
	SFP	1.49	1.53	1.56	1.59	1.67	1.71	1.85	2.06				
	kW	0.83	0.85	0.85	0.84	0.84	0.84	0.84	0.83				
75%	m³/s	0.40	0.39	0.38	0.35	0.33	0.30	0.22	0.09				
	SFP	0.91	0.96	0.97	1.06	1.13	1.23	1.55	2.93				
	kW	0.36	0.38	0.37	0.37	0.37	0.36	0.34	0.27				
50%	m³/s	0.25	0.23	0.21	0.16	0.09							
	SFP	0.51	0.56	0.60	0.76	1.20							
	kW	0.13	0.13	0.13	0.12	0.11							
25%	m³/s	0.09	0.04										
	SFP	0.32	0.63										
	kW	0.03	0.03										

## Sound Data - Sentinel Apex HR15

Speed	Test Mode	Sound Pressure level @ 3.0m dBA								
		63	125	250	500	1k	2k	4k	8k	
100%	Breakout	65	59	67	59	51	48	41	40	38
	Exhaust T4	63	60	46	64	62	57	46	36	
	Extract T3	69	67	80	72	64	61	57	57	
	Intake T1	70	67	79	69	65	62	57	53	
	Supply T2	63	59	74	65	62	57	46	40	
75%	Breakout	59	57	62	52	43	38	32	32	30
	Exhaust T4	57	57	65	57	53	47	36	29	
	Extract T3	64	64	72	65	56	53	48	50	
	Intake T1	63	65	74	62	56	52	47	47	
	Supply T2	56	56	67	57	53	58	36	33	
50%	Breakout	53	57	46	40	32	27	23	24	22
	Exhaust T4	50	53	48	43	41	35	24	24	
	Extract T3	55	61	60	53	45	40	40	34	
	Intake T1	56	62	60	51	45	40	38	28	
	Supply T2	49	52	50	43	41	35	25	24	
25%	Breakout	49	51	40	31	27	23	20	24	14
	Exhaust T4	49	38	34	25	24	22	17	24	
	Extract T3	52	42	42	31	26	26	18	24	
	Intake T1	51	42	41	30	27	23	18	23	
	Supply T2	47	36	33	25	24	21	16	23	

For full sound and performance data please use our Fan Selection Program [www.vent-axia.com/fanselector/product/apex](http://www.vent-axia.com/fanselector/product/apex)  
 Sound data derived from independent testing at Sound Research Laboratories in accordance with EN ISO 3741:2010. Published dB(A) figures are free field sound pressure levels at 3m with spherical propagation at a reference level of  $2 \times 10^{-5}$  Pa. The inlet/outlet sound power level spectra figures are dB with a reference of  $10^{-12}$  watts.

## Accessories

### Attenuator



Single skinned attenuators purpose designed for the Apex Heat Recovery range to minimise in duct noise. Attenuators are supplied in standard lengths of 900mm, 1200mm and 1500mm, constructed from Galvanised steel with profiled perforated sheet internal, mineral wool sound absorbing material and 30mm profiled flanges for duct and unit mounting. Data has been obtained by testing in accordance with BS EN ISO7235:2009.

Stock Ref.	Dimensions (mm)			kg	Insertion Loss dB						m <sup>3</sup> /hr @ Pa						
	Length	Width	Height		63	125	250	500	1k	2k	4k	8k	300	600	1000	1500	2000
ATT900-HR15	900	400	300	18	2	3	8	15	27	21	14	10	1	3	8	17	30
ATT1200-HR15	1200	400	300	23	2	4	10	19	36	24	16	12	1	3	8	18	32
ATT1500-HR15	1500	400	300	34	2	5	12	24	44	28	19	14	1	3	9	20	36

### Duct mounted Heating / Cooling



Rectangular duct mounted heater battery with either electric heating complete with integral thyristor controls, or LPHW water heating, each designed to provide approximately 10°C temperature rise. Chilled water cooler also available with integral condensate tray. Note waterside controls are not included.

Stock Ref.	Type	Dimensions (mm)			kg	Heater rating kW	Electrical supply	Water Temp			m <sup>3</sup> /hr @ Pa				
		Length	Width	Height				Flow	Return	Connection	300	600	1000	1500	2k
EHB-HR15	Heater with controls	300	400	300	7	5.00	230/1/50	N/A	N/A	N/A	1	3	8	18	32
HWB-HR15	HR 15 Duct mounted Rectangular LPHW heating battery	200	400	310	8	5.03	N/A	80°C	60°C	1/2"	1	3	8	18	32
CWB-HR15	HR 15 Duct mounted Rectangular water cooling battery	200	500	350	8	6.23	N/A	6°C	12°C	3/4"	1	3	8	18	32

### Roof Assembly

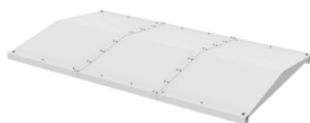

Stock Ref	Length mm	Width mm	Height mm	Weight kg
WRF-HR15	2400	1455	95	52

### Transformation Piece



Rectangular to round transformation piece designed to fix directly to the unit or any of the specific HR15 duct accessories to enable connection to 315mm round ducting.

Stock Ref	Length mm	Width mm	Height mm	Weight kg
495296	325	400	300	4

### Intake / Exhaust Cowl



Weather inlet/discharge cowl for external mounting (one required for each airstream).

Stock Ref	Length mm	Width mm	Height mm	Weight kg
496597	394	402	380	6

### Flexible Connection



Stock Ref	Length mm	Width mm	Height mm	Weight kg
497020	130	400	300	4



# Sentinel Apex HR21

- Very low sound levels independently tested and verified by SRL
- Low SFP utilising IE 5 equivalent motors
- High Heat Recovery Efficiency - up to 93% (EN308)
- Automatic summer bypass sized to eliminate performance loss
- ePM10 50% and ePM1 50% filters as standard (M5 / F7 equivalent)
- Filter access from bottom and side as standard
- Digital on board controller and remote room controller as standard
- App connectivity as standard
- Wired and Wireless communication sensors available
- Integral condensate tray and pump
- Electric frost protection heater as standard

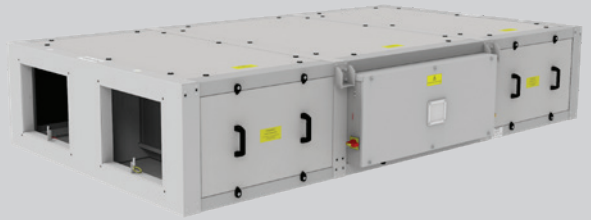

## Performance simply delivered with more as standard

Vent-Axia's Sentinel Apex range of commercial heat recovery units with up to 93% EN308 heat recovery efficiency, low sound levels and low specific fan powers the range provides high levels of performance efficiently. A new advanced control system that provides on board control, in room control and App based control full functionality commissioning and monitoring is simply provided. This control can be coupled with Vent-Axia's new range of sensors with wired or wireless communication providing close control of, and monitoring of your indoor air quality. Sensors include CO<sub>2</sub>, humidity and temperature and provide both proportional and switch control.

The Sentinel Apex HR21 unit is manufactured with a double skinned pentapost construction incorporating aluzinc frames and panels. The panels are acoustically and thermally treated with 90kg/m<sup>3</sup> high efficiency acoustic and thermally insulating foam (fire retardant to BS476 Part 7 Class 1 & Part 6 Class O). The construction of the unit, IPX4, allows for internal and external mounting as standard, however, the roof assembly should be included for full external locations.

The housing is designed to be as compact as possible for concealed false ceiling applications with top and bottom access panels for maintenance. Access panels are sized to enable single person maintenance.

The fans utilised in the Sentinel Apex HR21 are the latest EC/DC external rotor motors specifically chosen for their low power consumption and low noise characteristics. The assembly is dynamically balanced to DIN ISO 1940 Grade 6.3. Ball bearings are greased for life. Insulation is Class 'B' (from -25°C to +60°C). All models incorporate internal electronic overload protection and a soft start function.

The Sentinel Apex HR21 is complete as standard with ISO ePM10 50% (M5) extract filter and ISO ePM1 50% (F7) supply, complete with a filter change warning. Filters have been selected to fully comply with the requirements of ISO16890 whilst having low pressure loss characteristics.

An integral electric frost heater is included to provide frost protection of the cell and filters down to -10°C.

The unit is complete with an integral summer bypass facility which has been designed to provide full bypass without impact to the airflow or

power consumption of the unit whilst in bypass mode.

Airflow and power consumption tested in accordance with BS EN 5801. Sound data derived from independent testing at Sound Research Laboratories in accordance with EN ISO 3741:2010. Published dB(A) figures are free field sound pressure levels at 3m with spherical propagation at a reference level of 2 x 10<sup>-5</sup> Pa. The inlet/outlet sound power level spectra figures are dB with a reference of 10<sup>-12</sup> watts.

An integral condensate tray is fitted along with an internal quiet running high quality pump allowing for removal of the condensate via a 10mm condensate pipe.

To facilitate normal access and maintenance to the unit there are both side and bottom access panels as standard. Should it be required, all panels are removable allowing access and removal of the heat recovery cell and all other components. A lockable isolator is fitted to the control panel preventing accidental operation whilst any maintenance is being carried out.

The electrical supply for the unit is 230V +/- 10% / 50/60Hz / 1ph. A 24V DC power is available from the unit for powering any of the matched sensors and switches.

The Sentinel Apex HR21 unit is fitted with an integrated control system as standard with a purpose designed user interface controller incorporating an alphanumeric 2 line display with 4 button keypad for fan status and a basic commissioning setup mounted within the control panel. A remote HMI is also included for that can be mounted within the room that is being ventilated. This allows for local monitoring of the unit along with the commissioning set-up.

App based control is also available via the Vent-Axia Connect App. This provides detailed commissioning and monitoring information and the ability to control the unit remotely.

A full range of sensors is available including humidity, temperature and CO<sub>2</sub> monitoring. These sensors are available for both wired and wireless communication with the wireless sensors being either local mains or battery powered.

### Dimensions (mm)

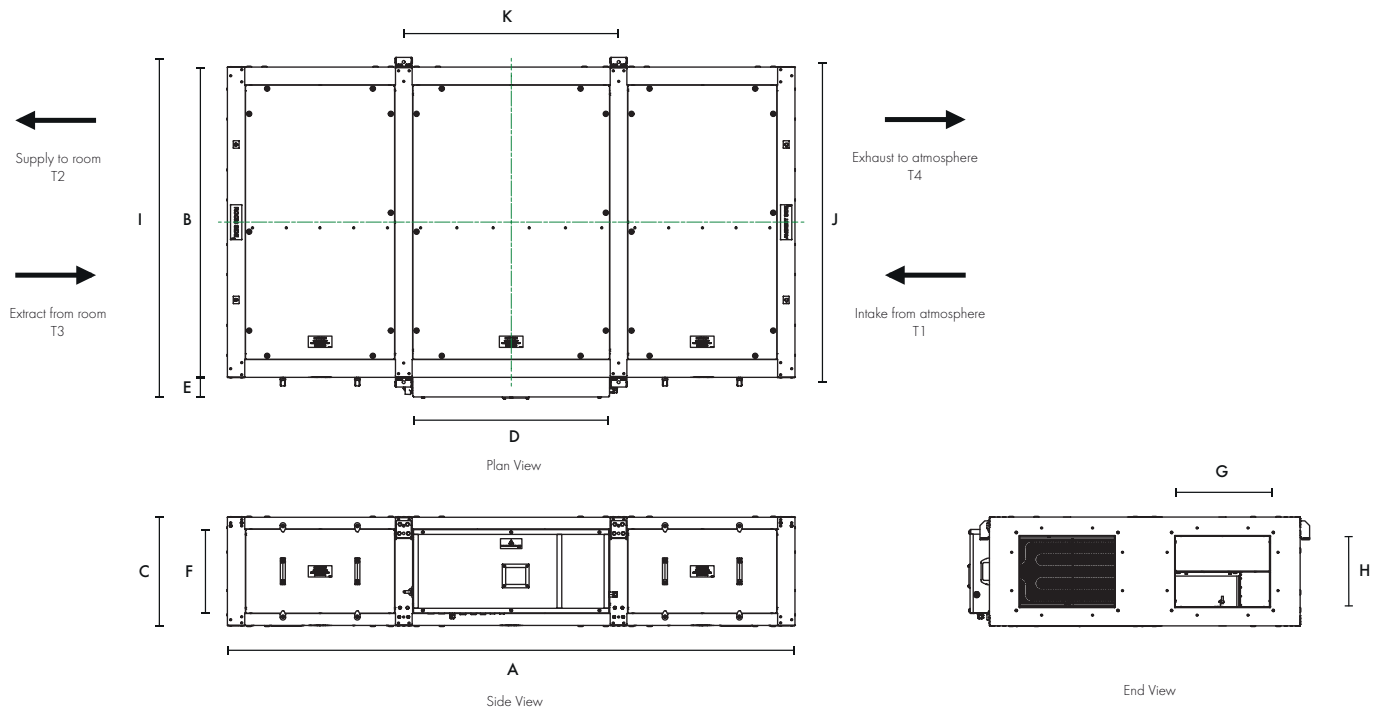

A (LENGTH)	B (WIDTH)	C (HEIGHT)	D	E	F	G	H	I	J	K	kg
2965	1319	620	1024	88	518	500	400	1446	1359	1097	470

### Heat Recovery Efficiency

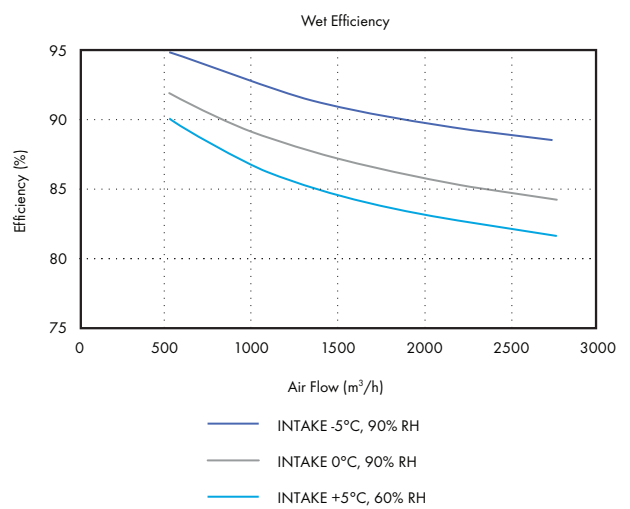
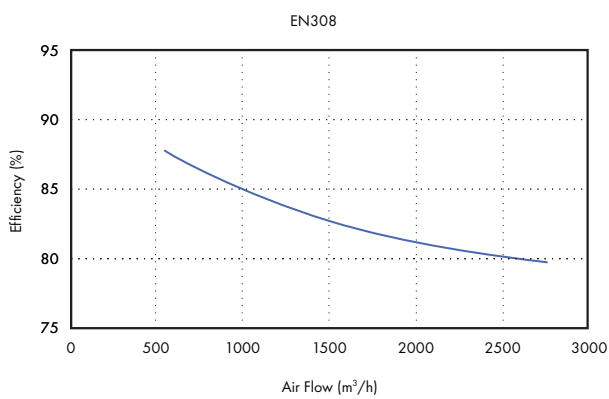

## Performance Guide - Sentinel Apex HR21

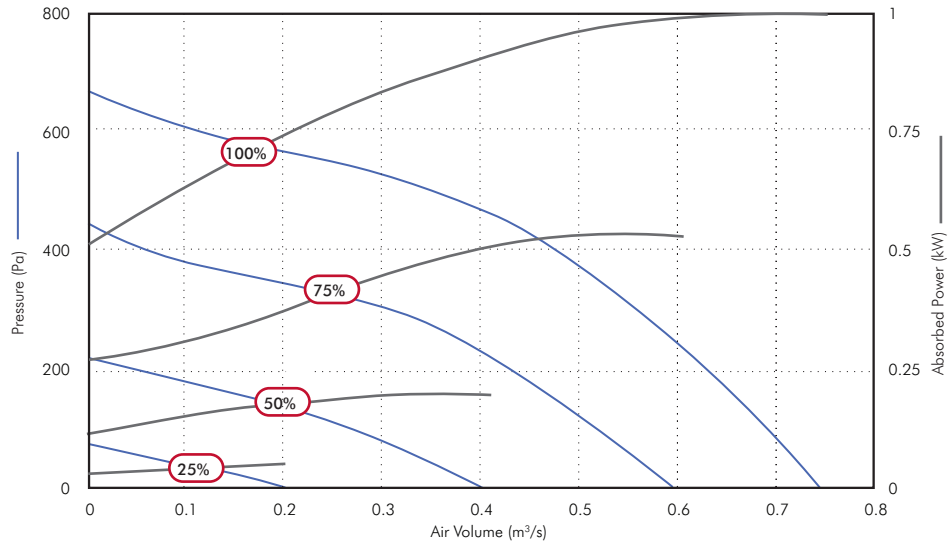

Speed	Airflow, m³/s @ Pa											Fans F.L.C.	Supply Voltage	Frost Heater	Unit Rated Current	
	0	25	50	100	150	200	250	300	400	500	600					
100%	m³/s	0.76	0.74	0.72	0.70	0.66	0.63	0.60	0.57	0.48	0.34	0.11	4.2A	230/1/50	7.8kW	39A
	SFP	1.31	1.36	1.40	1.45	1.52	1.59	1.64	1.72	2.00	2.53	6.08				
	kW	1.004	1.004	1.005	1.007	1.009	1.002	0.988	0.973	0.970	0.856	0.655				
75%	m³/s	0.60	0.59	0.56	0.52	0.49	0.43	0.38	0.31							
	SFP	0.89	0.92	0.97	1.04	1.09	1.22	1.32	1.49							
	kW	0.538	0.540	0.542	0.541	0.534	0.522	0.498	0.459							
50%	m³/s	0.41	0.39	0.35	0.27	0.17	0.03									
	SFP	0.53	0.55	0.62	0.75	1.08	5.22									
	kW	0.214	0.213	0.213	0.204	0.179	0.145									
25%	m³/s	0.20	0.15	0.08												
	SFP	0.30	0.39	0.59												
	kW	0.061	0.057	0.050												

## Sound Data - Sentinel Apex HR21

Speed	Test Mode	Sound Pressure level @ 3.0m dBA								
		63	125	250	500	1k	2k	4k	8k	
100%	Breakout	60	57	57	47	44	38	34	32	100%
	Exhaust T4	60	58	60	57	57	51	44	42	
	Extract T3	64	65	67	64	61	56	50	48	
	Intake T1	63	65	68	64	61	56	51	49	
	Supply T2	59	59	62	57	57	51	46	42	
75%	Breakout	54	57	50	42	37	34	28	25	75%
	Exhaust T4	54	58	52	49	50	44	37	33	
	Extract T3	58	65	63	56	53	49	43	41	
	Intake T1	57	63	61	58	53	48	43	41	
	Supply T2	52	54	52	48	50	44	39	34	
50%	Breakout	51	52	45	35	31	27	21	22	50%
	Exhaust T4	65	55	47	40	42	36	30	27	
	Extract T3	60	60	58	49	44	40	35	31	
	Intake T1	57	62	56	49	45	39	34	31	
	Supply T2	53	49	47	39	42	36	29	27	
25%	Breakout	48	39	42	24	22	17	18	22	25%
	Exhaust T4	48	35	35	29	31	23	20	25	
	Extract T3	57	44	44	37	34	29	21	26	
	Intake T1	53	43	46	37	32	56	20	25	
	Supply T2	44	34	34	28	30	22	19	25	

For full sound and performance data please use our Fan Selection Program [www.vent-axia.com/fanselector/product/apex](http://www.vent-axia.com/fanselector/product/apex)

Sound data derived from independent testing at Sound Research Laboratories in accordance with EN ISO 3741:2010. Published dB(A) figures are free field sound pressure levels at 3m with spherical propagation at a reference level of  $2 \times 10^{-5}$  Pa. The inlet/outlet sound power level spectra figures are dB with a reference of  $10^{-12}$  watts.

## Accessories

### Attenuator



Single skinned attenuators purpose designed for the Apex Heat Recovery range to minimise in duct noise. Attenuators are supplied in standard lengths of 900mm, 1200mm and 1500mm, constructed from Galvanised steel with profiled perforated sheet internal, mineral wool sound absorbing material and 30mm profiled flanges for duct and unit mounting. Data has been obtained by testing in accordance with BS EN ISO7235:2009.

Stock Ref.	Dimensions (mm)			kg	Insertion Loss dB								m <sup>3</sup> /hr @ Pa					
	Length	Width	Height		Weight	63	125	250	500	1k	2k	4k	8k	300	600	1000	1500	2000
ATT900-HR21	900	500	400	25	3	7	11	20	28	21	13	8	1	2	5	11	19	43
ATT1200-HR21	1200	500	400	32	4	9	15	26	35	26	15	10	1	2	5	12	21	47
ATT1500-HR21	1500	500	400	46	5	11	19	33	45	31	18	11	1	2	5	12	22	50

### Duct mounted Heating / Cooling



Rectangular Duct mounted heater battery with either electric heating complete with integral thyristor controls, or LPHW water heating, each designed to provide approximately 10°C temperature rise. Chilled water cooler also available with integral condensate tray. Note waterside controls are not included.

Stock Ref.	Type	Dimensions (mm)			kg	Heater rating kW	Electrical supply	Water Temp			m <sup>3</sup> /hr @ Pa					
		Length	Width	Height				Weight	Flow	Return	Connection	300	600	1000	1500	2000
EHB-HR21	HR 21 Duct mounted Rectangular electric heater with controls	300	500	400	10	7.50	230/1/50	N/A	N/A	N/A	1	2	5	12	21	47
HWB-HR21	HR 21 Duct mounted Rectangular LPHW heating battery	200	500	400	10	7.03	N/A	80°C	60°C	1/2"	1	2	5	12	21	47
CWB-HR21	HR 21 Duct mounted Rectangular water cooling battery	200	500	400	10	8.65	N/A	6°C	12°C	3/4"	1	2	5	12	21	47

### Roof Assembly

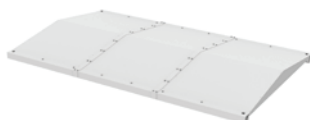

Stock Ref	Length mm	Width mm	Height mm	Weight kg
WRF-HR21	2965	1455	95	63

### Intake / Exhaust Cowl



Weather inlet/discharge cowl for external mounting (one required for each airstream).

Stock Ref	Length mm	Width mm	Height mm	Weight kg
497220	494	502	510	9

### Transformation Piece



Rectangular to round transformation piece designed to fix directly to the unit or any of the specific HR21 duct accessories to enable connection to 400mm round ducting.

Stock Ref	Length mm	Width mm	Height mm	Weight kg
497224	325	500	400	5

### Flexible Connection



Stock Ref	Length mm	Width mm	Height mm	Weight kg
497021	130	500	400	4



# Roof Fans



With one of the widest ranges of roof mounted fans Vent-Axia can provide a solution to any consultant's ventilation requirement whether in public, commercial or industrial applications. The architects need for an aesthetically pleasing low profile cowl are also provided for.

The latest generation of the Vent-Axia Sabre® Sickle fan assisted roof cowls incorporate the very latest FE2 Owlett impeller plate axial fans offering improved performance over the previous ranges with up to 7dB(A) reduction in sound and up to 15% improvement in efficiency ensuring the best available fan performance in its class. The advanced blade design is matched to a purpose designed external rotor motor to ensure unrivalled reliability and controllability.

Optional integral backdraught shutters limit heat loss from the building when the unit is off.

**Vent-Axia**





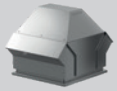

High Temperature Roof Fans (RDM)

03-06

---

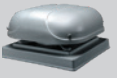

Sabre® Sickle Fan Assisted Roof Cowl (VSR)

07-014

---



Mixed Flow Roof Fans (RMH)

015-020

---

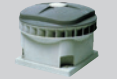

Lo-Carbon Energy Saver MX Roof Fans (MX)

021-024

---

# High Temperature Roof Fans (RDM)

- Handles air temperatures up to +120°C
- High performance directed vertical discharge
- Motor mounted outside of the airstream
- Manufactured from aluminium
- IP65 service isolator
- Integral backdraught shutter
- Manufacture controlled to ISO 9001:2015
- Performance tested to ISO 5801
- 2 Year Warranty

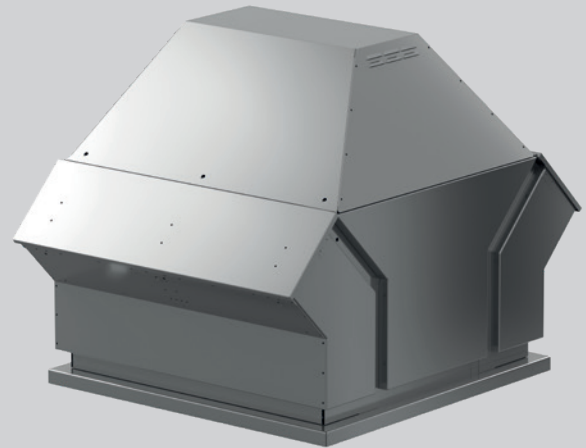

Designed to comply with the latest EU regulations for Ventilation units the RDM range of roof extract fans from Vent-Axia are suitable for both general ventilation and kitchen ventilation with in-duct temperatures of up to 120°C.

## Motors

High performance centrifugal impeller with backward curved blades directly fitted to a premium efficiency IE3 motor protected to IP55. The motor is fitted with PTC Thermistors as standard and is designed for best operation through a frequency inverter with sine filters. Balanced statically and dynamically according to DIN ISO 1940. Meets the efficiency requirements of Regulation EU1253/2014 ErP Lot 6 for ventilation units.

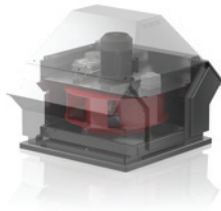

## Performance

The fan performance is tested in accordance with ISO 5801.

## Electrical

All models are suitable for 380-415 / 3 / 50 electrical supply.

## Sound

Sound measurements are made in accordance with DIN 45635-38. Inlet side is in accordance with ISO 5136 as an in-duct figure.

Discharge side is in accordance with DIN 45635-1 and BS848 part 2 as a free field figure.

## Accessories

### Flat roof upstand

Manufactured from galvanised sheet steel with sound absorbing and thermal lining.

### Inclined roof upstand

Upstand for inclined roof made of aluminium sheet, provided with sound and thermal insulation, available in steps of 5 degrees from 5 to 45 degrees roof pitch - to be advised at time of order.

### Intake flexible connection

Flanged flexible connection to prevent the transmission of vibration to other parts of the installation. Flange dimensions are in accordance with DIN 24 155 - 2.

### Protection grid for intake

Use in installations with an open inlet.

### Inlet silencer

The tubular inlet silencer has a square flange on the side nearest to the roof unit for bolting to the respective flat roof upstand. It slides inside the upstand, while the opposite end can take either additional ducting or an inlet cone.

The exterior skin is made of galvanised sheet steel, and the interior of galvanised perforated plate. The cavity between them is filled with non-flammable acoustic material.

There is no central core of material, so any pressure loss will be insignificant.

Stock Ref	dB	63	125	250	500	1k	2k	4k	8k
475820	7	0	3	5	10	14	13	8	7
475821	8	2	4	6	12	16	14	10	8
475822	12	2	4	8.5	17	20	15	12	10
475823	13	3	5	9	17	21	15	12	10
475824	13	3	5	10	18	22	16	12	10

For full details please contact Technical Support 0344 856 0595.

## Dimensions (mm)

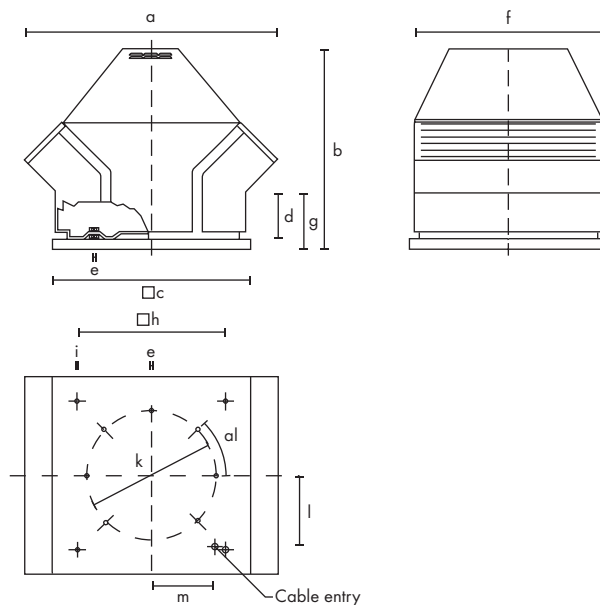

Stock Ref	a	α	b	c	d	e	f	g	h	i	k	l	m
RDM3E25284D	600	6x60°	543	440	32	M6	440	135	330	12	286	138	138
RDM3E25314D	600	6x60°	543	440	32	M6	440	135	330	12	286	138	138
RDM3E35354D	770	6x60°	635	600	32	M8	570	170	450	12	395	216	192
RDM3E354043	770	6x60°	635	600	32	M8	570	170	450	12	395	216	192
RDM3E354543	770	6x60°	635	600	32	M8	570	170	450	12	395	216	192
RDM3E455043	985	6x60°	775	750	32	M8	730	208	590	14	487	282	222
RDM3E455643	985	6x60°	775	750	32	M8	730	208	590	14	487	282	222
RDM3E455663	985	6x60°	775	750	32	M8	730	208	590	14	487	282	222
RDM3E566363	1125	8x45°	946	940	40	278	920	278	750	14	605	335	317
RDMFE567163	1125	8x45°	946	940	40	278	920	278	750	14	605	335	317
RDMFE718063	1625	8x45°	1195	1270	65	M10	1230	380	1050	14	751	500	445
RDMFE719063	1625	8x45°	1195	1270	65	M10	1230	380	1050	14	751	500	445

## Accessories



Fan  
Stock Ref



Flat roof upstand  
Stock Ref



Inclined roof upstand  
Stock Ref



Intake flexible connection  
Stock Ref



Protection grid for intake  
Stock Ref



Inlet silencer  
Stock Ref

RDM3E25284D	475776	475787	475798	475809	475820
RDM3E25314D	475776	475787	475798	475809	475820
RDM3E35354D	475777	475788	475799	475810	475821
RDM3E354043	475777	475788	475799	475810	475821
RDM3E455043	475778	475789	475800	475811	475822
RDM3E455643	475778	475789	475800	475811	475822
RDM3E455663	475778	475789	475800	475811	475822
RDM3E566363	475779	475790	475801	475812	475823
RDMFE567163	475779	475790	475801	475812	475823
RDMFE718063	475780	475791	475802	475813	475824
RDMFE719063	475780	475791	475802	475813	475824

Note. The accessories listed are bespoke to this product range, for full dimensional details please contact Technical Support



# Performance Guide

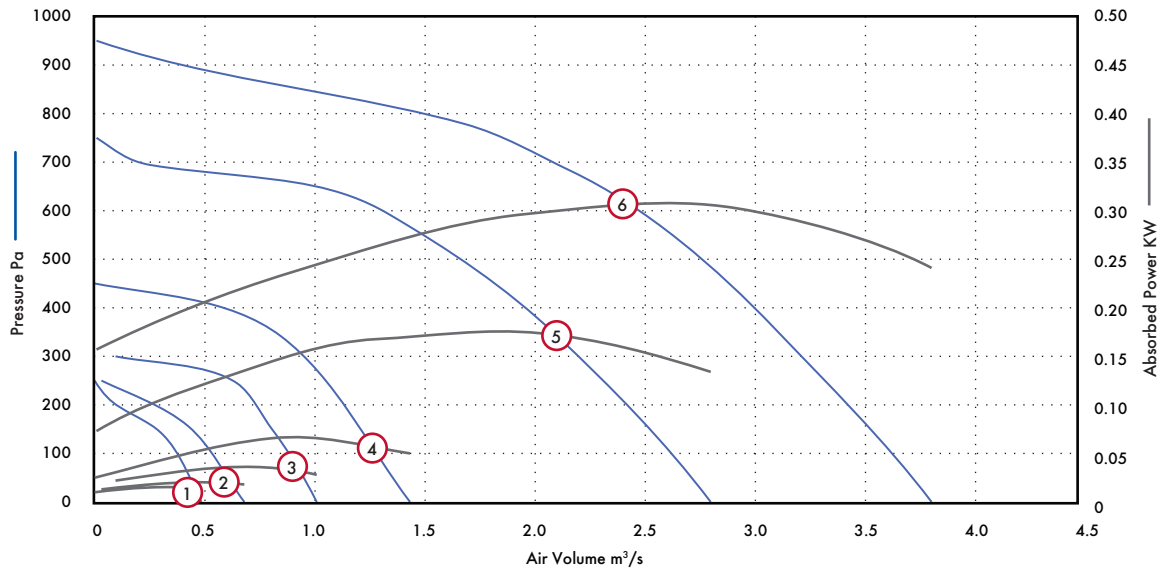

Stock Ref	Supply	r.p.m	Curve Ref	Air Volume m³/s												Motor kW	FLC	SC		
				0	100	200	300	400	500	600	700	800	900							
RDM3E25284D	400/3/50	1350	1	m³/s	0.49	0.37	0.07									0.25	0.84	2.52		
				kW	0.14	0.16	0.12													
RDM3E25314D	400/3/50	1350	2	m³/s	0.68	0.53	0.26									0.25	0.84	2.52		
				kW	0.18	0.21	0.19													
RDM3E35354D	400/3/50	1370	3	m³/s	1.01	0.89	0.72	0.10									0.37	1.11	3.33	
				kW	0.28	0.34	0.37	0.22												
RDM3E354043	400/3/50	1440	4	m³/s	1.43	1.28	1.13	0.94	0.58									0.55	1.25	3.75
				kW	0.50	0.57	0.65	0.68	0.58											
RDM3E455043	400/3/50	1420	5	m³/s	2.79	2.63	2.44	2.19	1.96	1.69	1.31	0.18					1.5	3.6	10.8	
				kW	1.34	1.47	1.61	1.68	1.75	1.77	1.68	0.96								
RDM3E455643	400/3/50	1430	6	m³/s	3.79	3.61	3.41	3.19	2.99	2.74	2.46	2.08	1.49	0.33			3	6.4	19.2	
				kW	2.41	2.59	2.74	2.85	2.98	3.05	3.07	2.98	2.72	1.93						

## Sound Power Level Spectra dB (re 10<sup>-12</sup>Watts)

Stock Ref		125	250	500	1k	2k	4k	8k	dBA
RDM3E25284D	Inlet	75	66	60	57	52	49	47	44
RDM3E25284D	Outlet	63	62	59	60	56	53	52	44
RDM3E25314D	Inlet	76	66	61	61	53	51	45	46
RDM3E25314D	Outlet	73	62	60	62	57	54	50	47
RDM3E35354D	Inlet	82	73	67	60	56	52	51	51
RDM3E35354D	Outlet	72	70	68	66	65	61	58	52
RDM3E354043	Inlet	84	76	70	64	58	54	52	53
RDM3E354043	Outlet	77	73	70	70	67	64	61	55
RDM3E455043	Inlet	93	81	76	72	66	67	62	61
RDM3E455043	Outlet	91	82	78	80	73	71	67	64
RDM3E455643	Inlet	96	86	81	78	74	72	68	66
RDM3E455643	Outlet	90	85	83	82	79	76	74	67

## Performance Guide

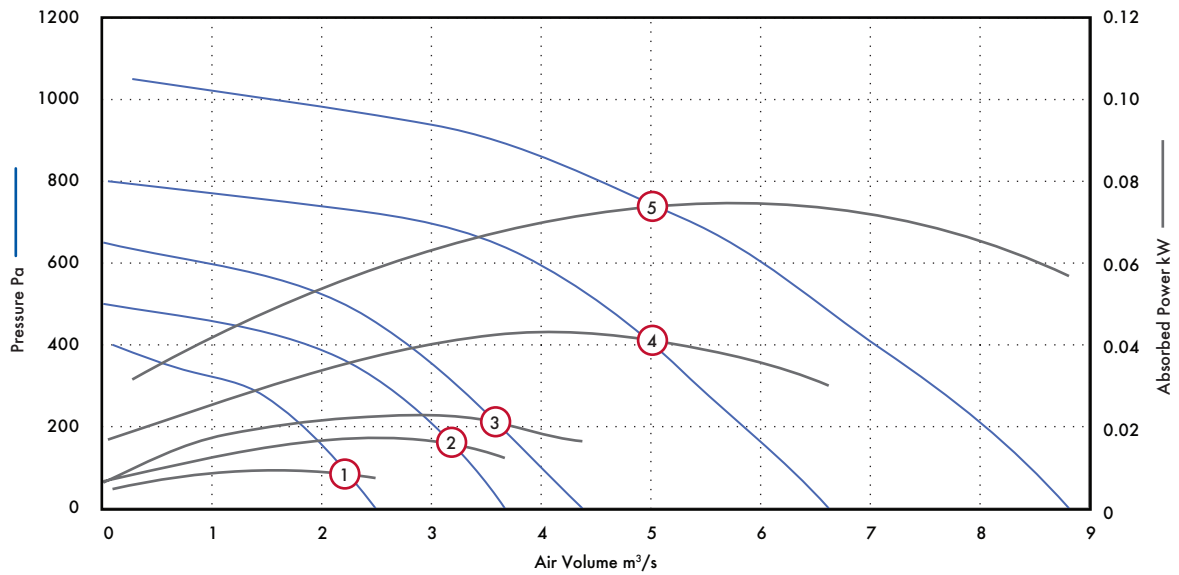

Stock Ref	Supply	r.p.m	Curve Ref												Motor kW	FLC	SC	
				0	100	200	300	400	500	600	700	800	900	1000				
RDM3E455663	400/3/50	935	1	m³/s	2.50	2.19	1.82	1.31	0.10							0.75	2.1	6.3
				kW	0.74	0.86	0.95	0.92	0.47									
RDM3E566363	400/3/50	950	2	m³/s	3.68	3.36	2.99	2.56	1.86	0.01						1.5	3.7	11.1
				kW	1.23	1.41	1.57	1.67	1.56	0.66								
RDMFE567163	400/3/50	965	3	m³/s	4.39	4.00	3.67	3.27	2.81	2.22	0.79					3	6.9	20.7
				kW	1.64	1.77	2.04	2.21	2.27	2.20	1.59							
RDMFE718063	400/3/50	970	4	m³/s	6.64	6.28	5.89	5.42	4.97	4.56	3.97	3.03	0.06			4	9	27
				kW	3.00	3.35	3.66	3.85	4.06	4.29	4.32	4.00	1.68					
RDMFE719063	400/3/50	950	5	m³/s	8.83	8.50	8.14	7.67	7.06	6.53	6.11	5.39	4.53	3.72	1.53	7.5	14.5	43.4
				kW	5.68	6.15	6.65	6.98	7.08	7.30	7.62	7.51	7.14	6.91	5.03			

## Sound Power Level Spectra dB (re 10<sup>-12</sup>Watts)

Stock Ref		125	250	500	1k	2k	4k	8k	dBA
RDM3E455663	Inlet	88	76	70	67	62	60	57	55
RDM3E455663	Outlet	77	75	73	72	69	66	63	57
RDM3E566363	Inlet	92	78	73	69	65	64	56	57
RDM3E566363	Outlet	85	79	77	74	71	68	62	59
RDMFE567163	Inlet	93	79	72	71	66	64	56	58
RDMFE567163	Outlet	80	81	76	76	73	69	63	61
RDMFE718063	Inlet	92	83	76	73	68	66	60	60
RDMFE718063	Outlet	86	84	79	77	74	71	67	63
RDMFE719063	Inlet	101	86	83	78	72	68	62	66
RDMFE719063	Outlet	91	87	84	82	78	74	70	67

# Sabre Sickle Fan Assisted Roof Cowls (VSR)

- Swept impeller with Aerofoil blades, winglets and serrated trailing edge for optimum performance
- Fully assembled cowl, separate plate axial fan
- Optional backdraught shutters and birdguard
- Moulded from recyclable polymeric material
- One shot die cast aluminium impeller dynamically balanced for smooth operation
- Resistant to UV light
- Speed controllable
- Thermal Overload Protection for motor protection
- Operating temperature up to 70°C



The latest generation of the Vent-Axia Sabre® Sickle Fan assisted roof cowls incorporate the very latest FE2 Owllet plate axial fans supplied separate to the cowl offering improved performance over the previous ranges with up to 7dB(A) reduction in sound and up to 15% improvement in efficiency ensuring the best available fan performance in its class. The advanced blade design is matched to a purpose designed external rotor motor to ensure unrivalled reliability and controllability.

All cowl and roof mounting plates are moulded from specially formulated polymeric materials, which are high impact resistant and provide a rigid profile against strong winds and are resistant to UV light. Standard Colour BS00A05. Alternative colours are available on request.

Suitable for flat or inclined roofs (max. angle 30°). Sabre® Sickle Fan assisted roof cowls are designed for either kerb or purlin box mounting. All sizes are fitted with inlet wire guards, giving protection to BS 848 part 5. Bird guards are available as optional accessories.

## Design and Development

Using a combination of NASA research into wing performance and winglets, coupled with a study of bird flight has enabled the development of the best available Sickle blade profile. Matching this to a purpose designed close fitting casing ensures best use of this blade technology thereby reducing noise and improving the performance in cased axial fans.

## Impellers

The impellers incorporate the latest in Sickle blade aerofoil technology to ensure minimum sound and maximum performance. The motors and impellers are factory matched, statically and dynamically balanced to ISO 1940 part 1, Quality Class G.6.3.

## Motors

The external rotor motors are specifically designed and styled for this range of fan. Ball bearings are greased for life. Sizes 315 - 710 motors are protected to IP54 against dust and moisture complying with BS EN 60529.

They have ribbed aluminium body castings for efficient cooling with Motor insulation to Class 'F' (from -40°C to +70°C). Speed controlled sizes 450

to 710, 6 & 8 pole motors are only suitable for operating temperatures of up to 40°C.

## Electrical

The Sabre® Sickle Fan assisted roof cowls range is available for either single phase 220-240V 50 Hz capacitor start and run or three phase 380-415V 50Hz. Motors are fitted with Thermal Overload Protection which should be wired into all controller circuits and into starter contacts to prevent motor damage due to overloading / overheating.

## Speed Control

Units are suitable for speed control by either electronic, voltage reduction or frequency inverters where permissible. For optimum efficiency and controllability Vent-Axia recommend the use of the eDemand Inverter controller to give close control via sensors or manual control.

## Terminal Box

An IP54 terminal box is supplied with all models with M20 x 1.5mm gland entry offering protection against dust and water.

## Performance

The fan performance is in accordance with tests to ISO 5801.

## Sound Levels

Fan sound levels are measured in a reverberant chamber in accordance with ISO 3744 Part 1. Published dB(A) figures are free field sound pressure levels at 3m with spherical propagation at a reference level of  $2 \times 10^{-5}$ Pa (20 micro-Pascal). The sound power level spectra figures are dB with a reference level of  $10^{-12}$  Watts (1 pico-watt).

To ensure minimum noise levels during speed control, either an auto transformer or eDemand inverter speed control is recommended.

## Packing

Sabre® Sickle Fan assisted roof cowls consist of two elements, a boxed cowl assembly and a plate mounted fan. Fan & cowl are supplied separately to assist with transportation and are quickly assembled on site.

## Accessories

A full range of accessories is available for the Sabre® Sickle Fan assisted roof cowls:

- Electronic Speed Controllers
- Auto Transformer Speed Controllers
- eDemand Inverter Speed Control
- D.O.L. Starters
- Purlin Boxes
- Backdraught Shutters
- Bird Guards
- Roof Attenuators

## Fan Dimensions (mm)

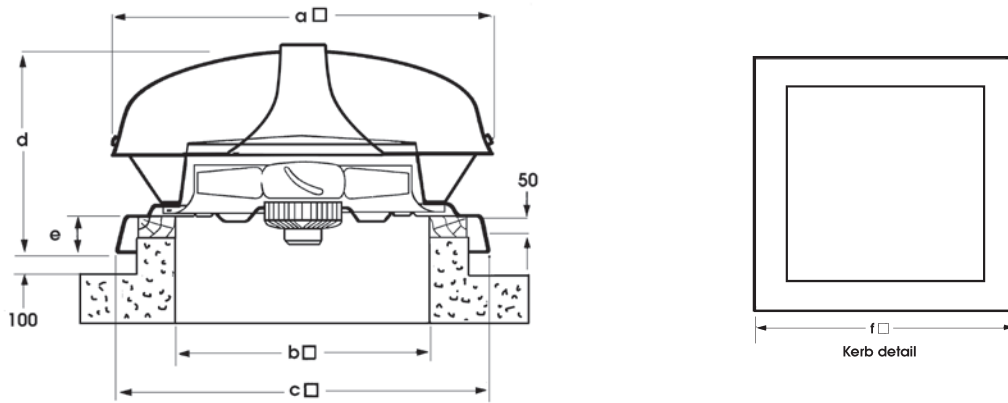

Dia	a □	b □	c □	d	e	f □	Kg max Kerb detail
250	700	475	737	411	97	675	11.7
315	700	475	737	411	97	675	12.8
355	700	475	737	411	97	675	13.8
400	800	575	830	466	97	775	19.2
450	800	575	830	466	97	775	24.8
500	950	715	1000	579	100	915	30.3
560	950	715	1000	579	100	915	37
630	1230	840	1100	731	105	1040	64
710	1230	840	1100	731	105	1040	50

# Performance Curve

250 - 355 dia. - 2 & 4 Pole

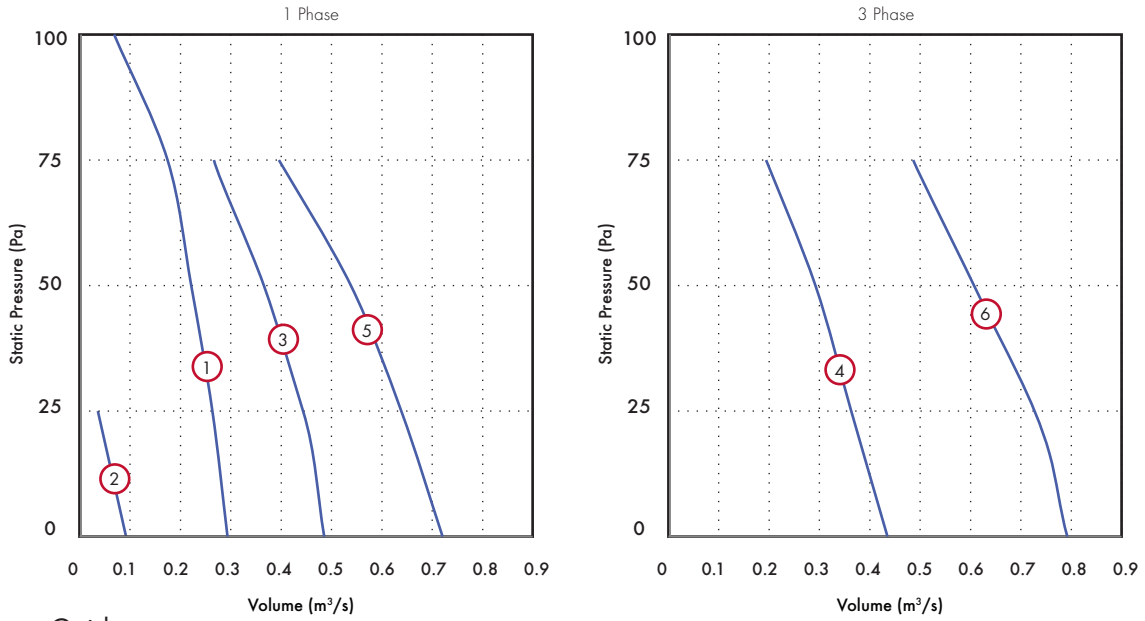

## Performance Guide

Stock Ref	Supply	IP	Motor Rating	F.L.C Amps	S.C. Amps	Poles	rpm	Curve	Volume m³/s @ Pa					dB(A) @ 3.0m	
									0	25	50	75	100		
VSR25012	230/1/50	IP54	0.12 kW	0.54	2.16	2	2160	1	Volume m³/s	0.29	0.26	0.22	0.18	0.07	50
									Power Watts	110	115	118	121	125	
VSR25014	230/1/50	IP54	0.05 kW	0.24	0.96	4	1370	2	Volume m³/s	0.09	0.04				37
									Power Watts	46	48				
VSR31514	230/1/50	IP54	0.12 kW	0.54	2.16	4	1360	3	Volume m³/s	0.49	0.44	0.37	0.27		45
									Power Watts	111	118	124	130		
VSR31534	400/3/50	IP54	0.12 kW	0.39	1.7	4	1450	4	Volume m³/s	0.44	0.36	0.29	0.19		47
									Power Watts	105	115	117	120		
VSR35514	230/1/50	IP54	0.13 kW	0.56	2.24	4	1260	5	Volume m³/s	0.72	0.64	0.54	0.40		46
									Power Watts	132	141	151	162		
VSR35534	400/3/50	IP54	0.19 kW	0.4	1.6	4	1390	6	Volume m³/s	0.79	0.72	0.61	0.49		48
									Power Watts	152	168	176	178		

## Sound Power Level Spectra dB (ref 10<sup>-12</sup> Watts)

Stock Ref	63Hz	125Hz	250Hz	500Hz	1KHz	2KHz	4KHz	8KHz	dB(A) @ 3.0m
VSR25012	65	70	68	66	64	66	62	55	50
VSR25014	56	63	56	54	53	53	49	41	37
VSR31514	71	70	65	60	58	59	55	47	45
VSR31534	75	71	62	60	61	62	59	51	47
VSR35514	67	70	67	64	58	60	53	45	46
VSR35534	74	66	61	63	64	63	59	53	48

## Performance Curve

400 - 450 dia. - 4 & 6 Pole

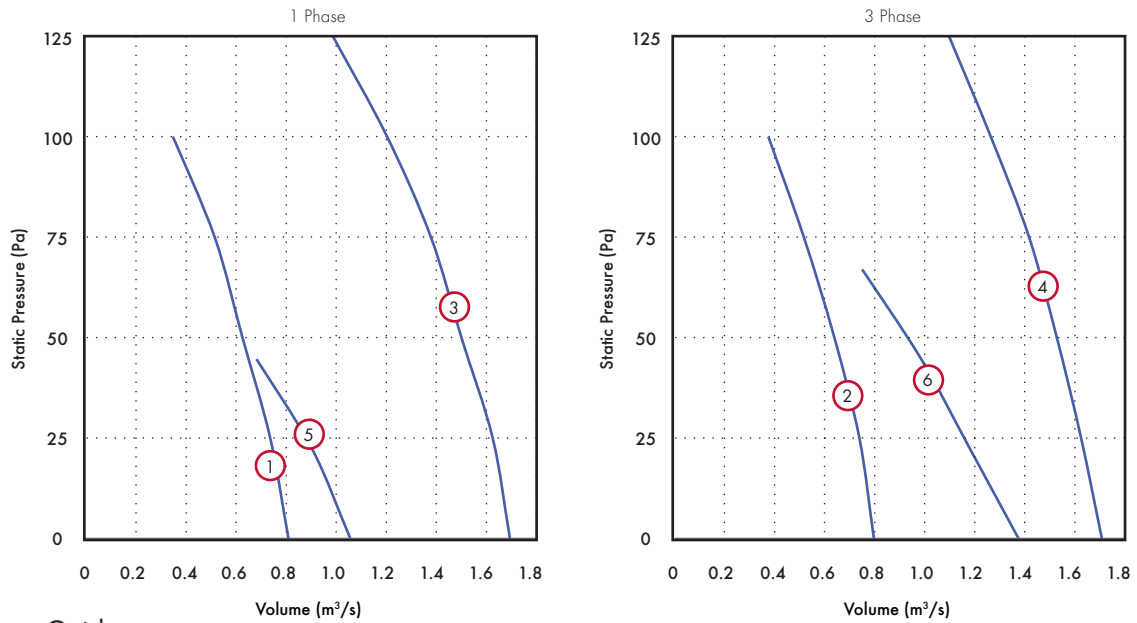

## Performance Guide

Stock Ref	Supply	IP	Motor Rating	F.L.C. kW	S.C. Amps	Poles	rpm	Curve	Volume m³/s @ Pa						dB(A) @ 3.0m
									0	25	50	75	100	125	
VSR40014	230/1/50	IP54	0.24	1.05	4.2	4	1340	①	0.81	0.74	0.63	0.51	0.35		46
VSR40034	400/3/50	IP54	0.23	0.46	1.6	4	1360	②	0.80	0.74	0.64	0.52	0.38		47
VSR45014	230/1/50	IP54	0.6	2.9	11.6	4	1320	③	1.69	1.63	1.50	1.38	1.20	0.99	49
VSR45034	400/3/50	IP54	0.54	1.1	4.4	4	1350	④	1.71	1.63	1.53	1.42	1.26	1.10	49
VSR45016	230/1/50	IP54	0.19	0.9	3.6	6	910	⑤	1.06	0.90	0.68				41
VSR45036	400/3/50	IP54	0.36	0.66	2.64	6	1020	⑥	1.38	1.18	0.99	0.75			44

## Sound Power Level Spectra dB (ref 10<sup>-12</sup> Watts)

Stock Ref	63Hz	125Hz	250Hz	500Hz	1KHz	2KHz	4KHz	8KHz	dB(A) @ 3.0m
VSR40014	72	73	66	62	60	59	54	48	46
VSR40034	67	67	61	60	60	59	54	48	47
VSR45014	67	69	71	63	63	63	59	53	49
VSR45034	72	70	65	65	64	64	59	53	49
VSR45016	57	62	59	56	56	56	50	41	41
VSR45036	71	66	60	60	60	58	51	43	44

# Performance Curve

500 - 560 dia. - 4 & 6 Pole

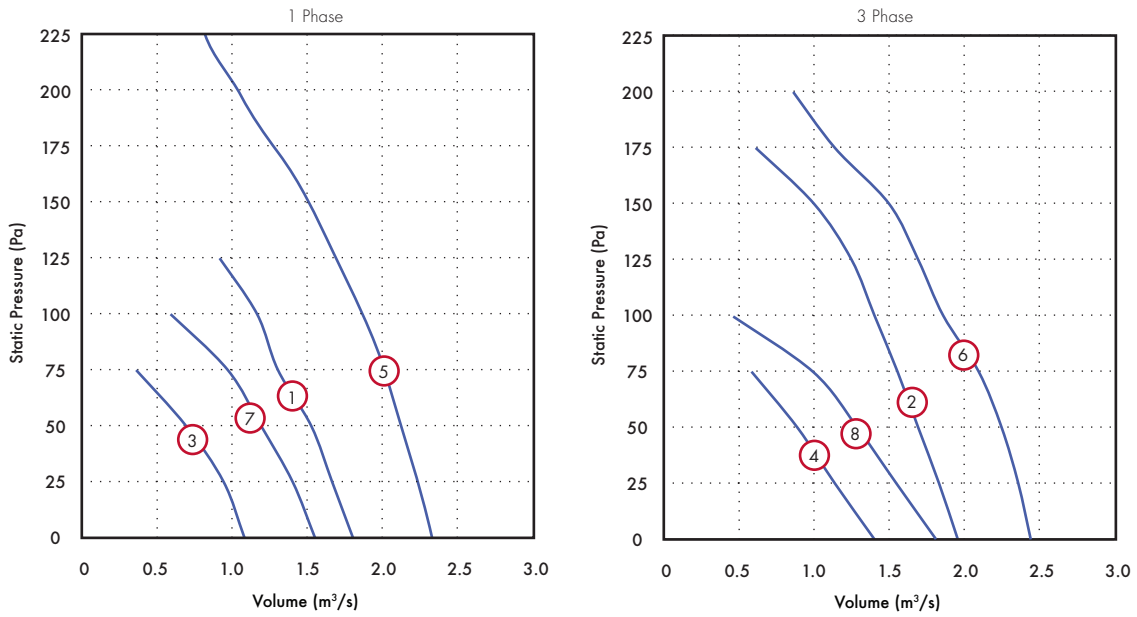

## Performance Guide

Stock Ref	Supply	IP	Motor Rating	F.L.C. kW	S.C. Amps	Poles	rpm	Curve	Volume m³/s @ Pa										dB(A) @ 3.0m		
									0	25	50	75	100	125	150	175	200	225			
VSR50014	230/1/50	IP54	0.72	3.2	12.8	4	1230	①	Volume m³/s	1.81	1.67	1.53	1.31	1.17	0.92						51
									Power Watts	630	660	670	690	720	740						
VSR50034	400/3/50	IP54	0.84	1.45	5.8	4	1340	②	Volume m³/s	1.96	1.83	1.70	1.56	1.40	1.25	1.00	0.61			52	
									Power Watts	620	650	680	720	740	750	800	825				
VSR50016	230/1/50	IP54	0.27	1.25	5	6	910	③	Volume m³/s	1.08	0.94	0.69	0.36								44
									Power Watts	250	265	280	295								
VSR50036	400/3/50	IP54	0.54	0.96	3.84	6	940	④	Volume m³/s	1.40	1.14	0.89	0.58								47
									Power Watts	470	500	520	540								
VSR56014	230/1/50	IP54	1.15	5.6	20	4	1330	⑤	Volume m³/s	2.33	2.25	2.11	2.03	1.87	1.67	1.56	1.28	1.04	0.80	62	
									Power Watts	810	830	870	890	900	980	1000	1050	1100	1110		
VSR56034	400/3/50	IP54	1.05	2.2	8.8	4	1280	⑥	Volume m³/s	2.44	2.36	2.25	2.10	1.86	1.69	1.50	1.14	0.86	57		
									Power Watts	742	800	840	860	910	920	940	1014	1044			
VSR56016	230/1/50	IP54	0.39	1.8	7.2	6	930	⑦	Volume m³/s	1.55	1.40	1.19	0.97	0.59							50
									Power Watts	369	394	415	438	458							
VSR56036	400/3/50	IP54	0.58	1.1	4.4	6	910	⑧	Volume m³/s	1.81	1.55	1.29	1.00	0.47							51
									Power Watts	489	518	542	556	576							

## Sound Power Level Spectra dB (ref 10<sup>-12</sup> Watts)

Stock Ref	63Hz	125Hz	250Hz	500Hz	1KHz	2KHz	4KHz	8KHz	dB(A) @ 3.0m
VSR50014	71	75	67	63	67	68	60	52	51
VSR50034	74	72	66	66	68	68	62	56	52
VSR50016	66	72	70	55	59	58	51	43	44
VSR50036	77	77	72	66	64	61	54	47	47
VSR56014	79	78	74	74	77	77	73	66	62
VSR56034	84	78	76	74	75	74	70	63	57
VSR56016	75	73	66	65	67	66	60	54	50
VSR56036	77	77	67	66	67	66	60	54	51

## Performance Curve

630 - 710 dia. - 4 & 6 & 8 Pole

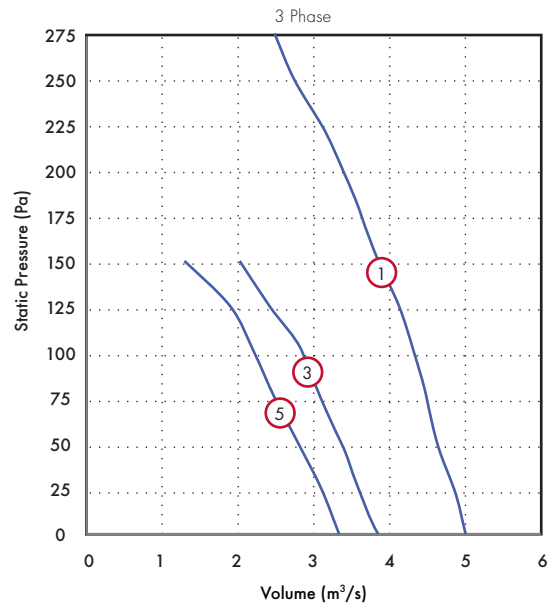
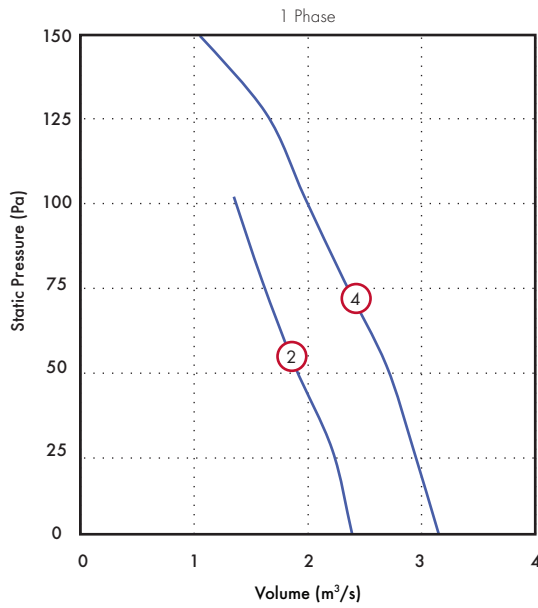

## Performance Guide

Stock Ref	Supply	IP	Motor Rating kW	F.L.C Amps	S.C. Amps	Poles	rpm	Curve	Volume m <sup>3</sup> /s @ Pa										dB(A) @ 3.0m			
									0	25	50	75	100	125	150	175	200	225		250	275	
VSR63034	400/3/50	IP54	2.4	4.6	18.4	4	1320	①	Volume m <sup>3</sup> /s	5.00	4.85	4.62	4.49	4.32	4.13	3.85	3.63	3.40	3.10	2.74	2.48	62
									Power Watts	2305	2350	2400	2450	2500	2540	2587	2600	2628	2630	2639	2659	
VSR63016	230/1/50	IP54	0.6	2.8	11.2	6	910	②	Volume m <sup>3</sup> /s	2.39	2.21	1.88	1.60	1.35							52	
									Power Watts	568	603	650	679	710								
VSR63036	400/3/50	IP54	1.5	2.6	10.4	6	1040	③	Volume m <sup>3</sup> /s	3.85	3.55	3.36	3.10	2.85	2.42	2.02						57
									Power Watts	1538	1550	1593	1610	1645	1661	1666						
VSR71016	230/1/50	IP54	0.95	4.4	17.6	6	850	④	Volume m <sup>3</sup> /s	3.15	2.93	2.69	2.32	1.97	1.63	0.99						52
									Power Watts	607	666	700	760	808	850	950						
VSR71036	400/3/50	IP54	0.94	1.7	6.8	6	900	⑤	Volume m <sup>3</sup> /s	3.33	3.10	2.79	2.48	2.21	1.90	1.29						49
									Power Watts	560	620	700	768	813	861	920						

## Sound Power Level Spectra dB (ref 10<sup>-12</sup> Watts)

Stock Ref	63Hz	125Hz	250Hz	500Hz	1KHz	2KHz	4KHz	8KHz	dB(A) @ 3.0m
VSR63034	85	80	77	75	78	77	71	66	62
VSR63016	74	71	73	68	68	66	60	54	52
VSR63036	84	75	71	71	74	71	65	59	57
VSR71016	81	81	72	69	70	67	61	57	52
VSR71036	69	69	68	67	68	65	59	52	49



## Pressure Drop for Roof Cowl only

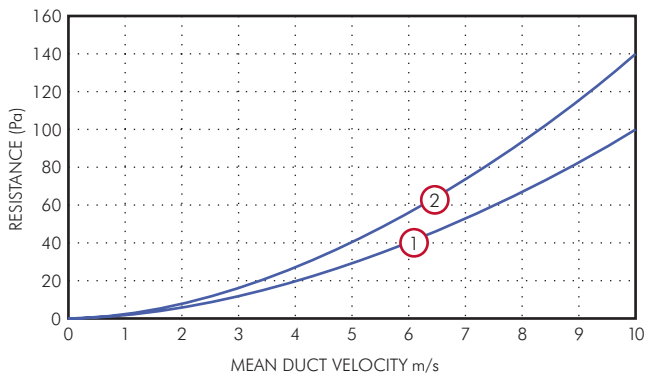

Stock Ref	Free area m <sup>2</sup>	Resistance curve	Cowl only weight kg
RCZ300	0.099	①	7.5
RCZ400	0.159	②	9
RCZ500	0.246	②	13
RCZ630	0.396	③	19

## Vertical Backdraught Shutters

Size	Percentage reduction in performance at 4 pole speeds
315	7%
355	12%
400	10%
450	*3%
500	*4%
560	*6%
630	*3%
710	*7%

\* For 6 and 8 pole fans, reduce percentages by ratio of fan speeds.

## Purlin Box

(Manufactured from 1.5mm pre-galv. mild steel)

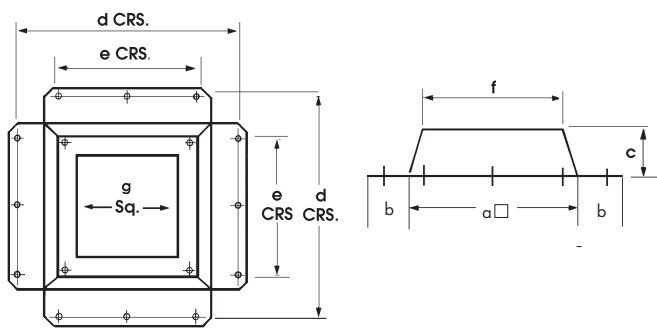

Size	a □	b	c	d	e	f	g
250/315/355	625	90	240	765	400	590	460
400/450	725	90	240	865	500	705	565
500	890	70	250	990	650	864	640
560	890	70	250	990	650	864	700
630	1030	75	250	1140	760	985	775
710	1030	75	250	1140	760	985	840

## Roof Attenuators

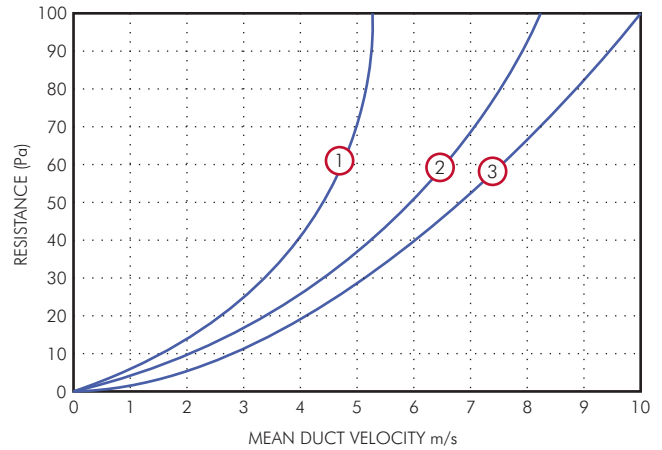
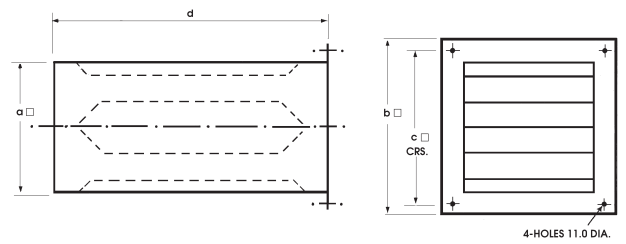

Stock Ref	a	b	c	d	Kg approx	Free area m <sup>2</sup>	Resistance curve
RAZ300600	455	535	505	600	18	0.156	①
RAZ400600	555	635	605	600	22	0.245	②
RAZ500600	635	790	745	600	31	0.416	②
RAZ600600	770	935	890	600	44	0.616	③
RAZ300900	455	535	505	900	21	0.156	①
RAZ400900	555	635	605	900	28	0.245	②
RAZ500900	635	790	745	900	39	0.416	②
RAZ600900	770	935	890	900	52	0.616	③
RAZ3001200	455	535	505	1200	25	0.156	①
RAZ4001200	555	635	605	1200	35	0.245	②
RAZ5001200	635	790	745	1200	48	0.416	②
RAZ6001200	770	935	890	1200	61	0.616	②

\* Recommended maximum duty velocity 10m/s

## Typical Installation

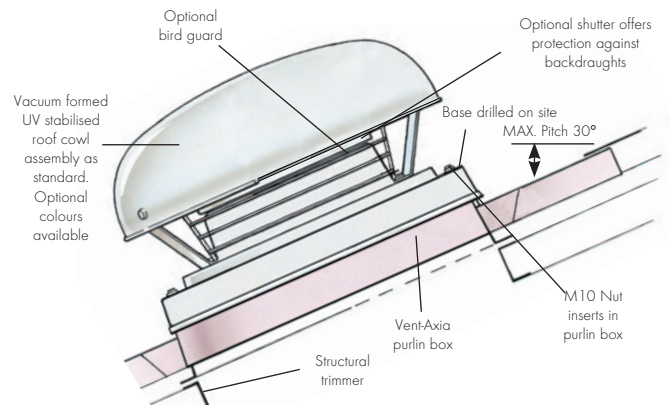

## Accessories



Stock Ref	Supply	Electronic Controller	5 Step Auto Transformer	D.O.L Starter	Overload	eDemand** Voltage Control*	eDemand** 3ph Inverter
VSR25012A	230/1/50	SC5030TK	10314102A	444744	444698	444164	-
VSR25014A	230/1/50	SC5001	10314102A	444744	444697	444164	-
VSR31514A	230/1/50	SC5001	10314102A	444744	444699	444164	-
VSR31534A	400/3/50	-	10314301A	444747	444699	444166	444172
VSR35514A	230/1/50	SC5030TK	10314102A	444744	444699	444164	-
VSR35534A	400/3/50	-	10314301A	444747	444698	444166	444172
VSR40014A	230/1/50	SC5030TK	10314102A	444744	444700	444164	-
VSR40034A	400/3/50	-	10314301A	444747	444698	444166	444172
VSR45014A	230/1/50	SC5060TK	10314103	444744	444702	444164	-
VSR45034A*	400/3/50	-	10314302A	444747	444700	444166	444172
VSR45016A	230/1/50	SC5030TK	10314102A	444744	444699	444164	-
VSR45036A*	400/3/50	-	10314301A	444747	444699	444166	444172
VSR50014A	230/1/50	SC5060TK	10314105	444744	444702	444164	-
VSR50034A*	400/3/50	-	10314302A	444747	444700	444166	444172
VSR50016A	230/1/50	SC5030TK	10314102A	444744	444700	444164	-
VSR50036A*	400/3/50	-	10314302A	444747	444700	444166	444172
VSR56014A	230/1/50	SC5010TK	10314113A	444744	444703	444165	444170
VSR56034A*	400/3/50	-	10314304A	444747	444702	444166	444172
VSR56016A	230/1/50	SC5030TK	10314103	444744	444702	444164	-
VSR56036A*	400/3/50	-	10314302A	444747	444700	444166	444172
VSR63034A	400/3/50	-	10314307A	444747	444703	444166	444173
VSR63016A	230/1/50	SC5060TK	10314105	444744	444702	444164	-
VSR63036A*	400/3/50	-	10314304A	444747	444702	444166	444173A
VSR71016A	230/1/50	SC5060TK	10314105	444744	444703	444164	-
VSR71036A*	400/3/50	-	10314302A	444747	444701	444166	444172

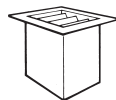

Roof Attenuator

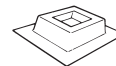

Purlin Boxes



Shutter

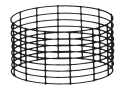

Bird Guard

Model Ref	Roof Attenuator			Purlin Stock Ref	Shutter Stock Ref	Bird Guard Stock Ref
	600mm Stock Ref	900mm Stock Ref	1200mm Stock Ref			
VSR250	RAZ300600	RAZ300900	RAZ3001200	PBZ300	RSZ300	BGZ300
VSR315	RAZ300600	RAZ300900	RAZ3001200	PBZ300	RSZ300	BGZ300
VSR355	RAZ300600	RAZ300900	RAZ3001200	PBZ300	RSZ300	BGZ300
VSR400	RAZ400600	RAZ400900	RAZ4001200	PBZ400	RSZ400	BGZ400
VSR450	RAZ400600	RAZ400900	RAZ4001200	PBZ400	RSZ400	BGZ400
VSR500	RAZ500600	RAZ500900	RAZ5001200	PBZ500	RSZ500	BGZ500
VSR560	RAZ500600	RAZ500900	RAZ5001200	PBZ560	RSZ500	BGZ500
VSR630	RAZ600600	RAZ600900	RAZ6001200	PBZ630	RSZ630	BGZ630
VSR710	RAZ600600	RAZ600900	RAZ6001200	PBZ710	RSZ630	BGZ630

\*\* For full range of speed controller options, see Accessories & Controllers Section.

\*Three phase models are supplied with 2 speed delta/star connection motors, as standard. (Sizes 450 to 630 are 4/6 Pole, 710 are 6/8 pole).

When low noise levels are required on all other models a 5 step auto transformer speed controller is recommended.

Optional coloured Cowls and Bases available on request.

# Mixed Flow Roof Fans (RMH)

- Motors protected to IP44
- Motor insulation Class 'B'
- Maximum operating temperature 40°C
- Standard Thermal Overload Protection
- IP65 service isolator
- Bird guard included as standard
- Speed controllable
- Performance tested to BS 848 parts 1 & 2
- Manufacture controlled to BS EN ISO 9001:2015
- 2 Year Warranty



Specially designed for use when medium pressure characteristics are required, the Vent-Axia Mixed Flow Roof range is delivered on-site fully assembled and ready for installation. To meet COSHH requirements, a service isolator is fitted and pre-wired as standard. Equally suitable for flat or inclined roofs, the range is suitable for kerb or purlin box mounting and boasts a wide range of accessories to suit many different industrial applications. There are five sizes available with duties ranging from 0.606m<sup>3</sup>/s to 3.63m<sup>3</sup>/s (2182m<sup>3</sup>/h to 13068m<sup>3</sup>/h) with pressure development available up to 600 Pa.

The mounting plate is moulded with a fixed integral bellmouth to ensure optimum efficiency and precise alignment. The weather-cowl is also moulded to produce a smooth, internal surface and a tough, stable UV resistant finish. Colour: BS 10A07. Alternative colours available on request.

Vent-Axia mixed flow roof fans are designed for either kerb or inclined fixing (maximum angle 30°).

## Electrical

Single phase 220-240V 50 Hz. Capacitor start and run. Three phase 380-415V 50Hz. A service isolator switch is provided for local isolation and the enclosure is protected to IP65 according to BS EN 60529. All motors are fitted with Standard Thermal Overload Protection (S.T.O.P.), which for three phase fans should be wired into all controller circuits and into starter contactors. Most models are available with 4 and 6 pole motors.

## Motors

The Mixed Flow roof range features a proven external rotor motor and backward curved mixed flow glass reinforced polyamide impeller selected for performance and non-overloading characteristics. The assembly is dynamically balanced to VDI 2060. The motors in this range are rated IP44 according to BS EN 60529. Ball bearings are greased for life and



are designed to run at any angle. Insulation is Class 'B' (from -30°C to +40°C). Manufacture is controlled to BS EN ISO 9001:2015 standards.

## Sound Levels

Published dB(A) figures are free field sound pressure levels at 3m with spherical propagation at a reference level of 2 x 10<sup>-5</sup>Pa (20 micro-Pascal). The sound power level spectra figures are dB with a reference level of 10<sup>-12</sup> Watts (1 pico-watt).

## Performance

Tested to BS 848 Parts 1 & 2.

## Accessories

### Purlin boxes

Available in sizes to suit all models and should be used to support the fan in conjunction with a soaker flange sheet.

### Roof attenuators

Available in all sizes to cover the range of Mixed Flow Roof fans in three lengths: 600, 900 or 1200mm according to the attenuation required.

### Shutters

Robust construction, designed to fit beneath the fan using the fittings provided. Airflow operated, manual or motorised shutter. A minimum distance of half the attenuator width is required between an airflow shutter and a roof attenuator for satisfactory operation.

### Fan Dimensions (mm)

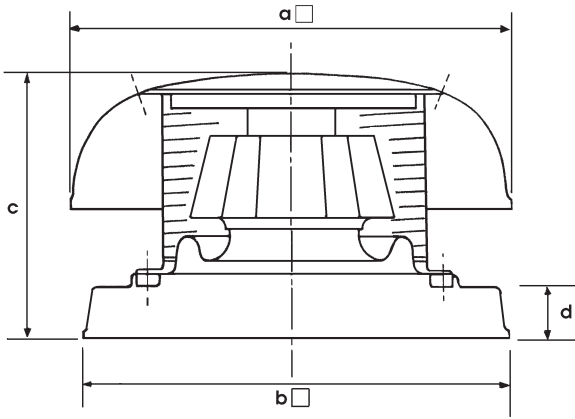

Fan size	a □	b □	c	d	Weight kg
250	500	500	280	90	16
315	700	680	410	83	16
355 / 400	800	780	480	83	24/27
450	950	930	575	103	45
500 / 560	1230	1055	630	103	48 / 64

### Details for Purlin Mounting

(Manufactured from 1.5mm pre-galv. mild steel).

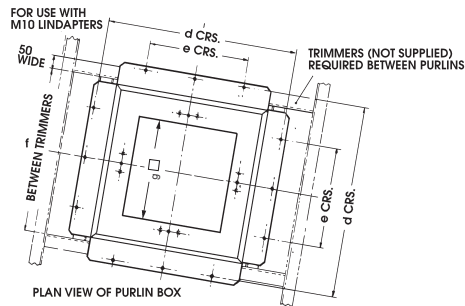
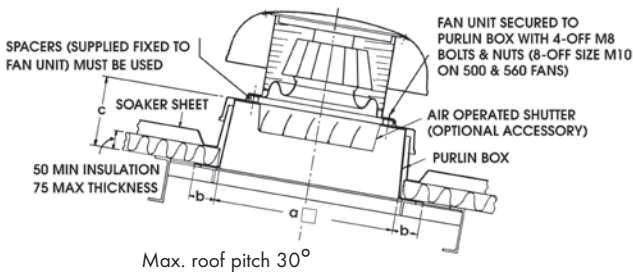

Fan size	a □	b	c	d	e	f	g □
315	625	90	240	765	400	653	400
355 / 400	725	90	240	865	500	753	500
450	890	70	250	990	650	878	650
500 / 560	1030	75	250	1140	760	1028	790

### Details for Kerb Mounting

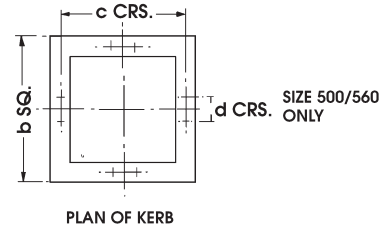
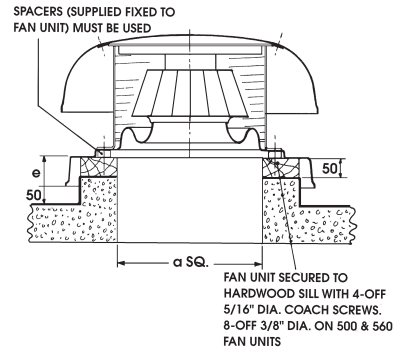

Fan size	a □	b □	c	d	e
250	350	450	400	-	90
315	400	600	470	-	83
355 / 400	500	700	570	-	83
450	650	850	690	-	103
500 / 560	790	990	842	100	103

# Performance Curve

250 - 560 dia - 4 Pole - 1 & 3 Phase

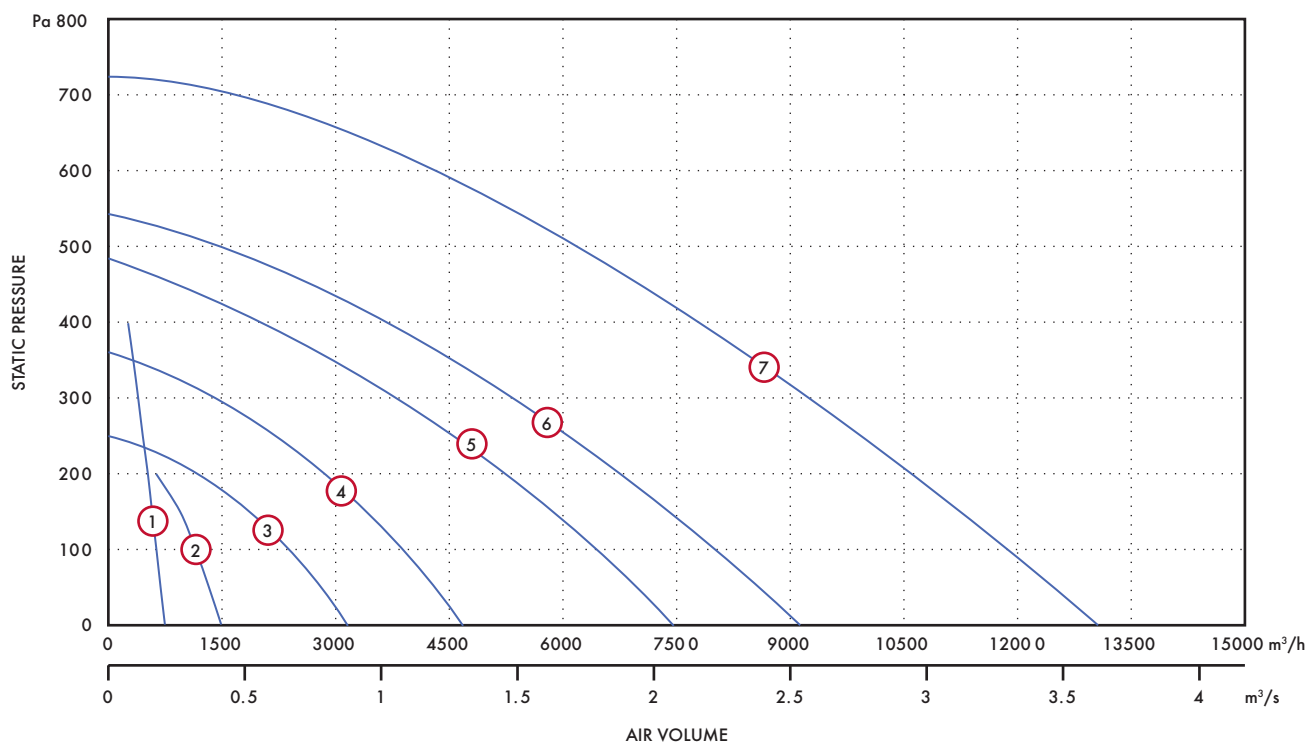

## Performance Guide

Dia.	Phase	Stock Model	Stock Ref	Pole	rpm	Curve		m³/s at Pa							Motor kW	S.C. Amps	F.L.C. Amps	dBA @ 3m	
						Ref	rpm	0	50	100	150	200	250	300					350
250	1	RMH25012		2	2720	1	0.25	0.23	0.21	0.19	0.17	0.15	0.13	0.11	0.09	0.16	2.1	0.7	62
315	1	RMH31514		4	1400	2	0.49	0.44	0.38	0.31	0.21					0.17	1.4	0.8	52
355	1	RMH35514		4	1410	3	0.87	0.77	0.65	0.51	0.33					0.31	4	1.45	56
400	1	RMH40014		4	1340	4	1.30	1.19	1.07	0.95	0.80	0.60	0.37			0.52	6	2.4	58
400	3	RMH40034		4	1340	4	1.30	1.19	1.07	0.95	0.80	0.60	0.37			0.54	4.2	1.05	58
450	1	RMH45014		4	1380	5	2.05	1.92	1.77	1.62	1.45	1.26	1.05	0.82	0.57	0.96	10.5	4.7	64
450	3	RMH45034		4	1380	5	2.05	1.92	1.77	1.62	1.45	1.26	1.05	0.82	0.57	0.89	5.9	1.65	64
500	1	RMH50014		4	1370	6	2.51	2.35	2.18	2.02	1.83	1.64	1.44	1.22	0.99	1.45	16	6.6	69
500	3	RMH50034		4	1370	6	2.51	2.18	2.02	1.83	1.64	1.44	1.22	0.99		1.35	10	2.4	69
560	3	RMH56034		4	1380	7	3.63	3.46	3.31	3.13	3.00	2.82	2.59	2.45	2.24	2.4	22	4.7	70

## Sound Power Level Spectra dB (re 10<sup>-12</sup>Watts)

Diameter	Pole	63	125	250	500	1k	2k	4k	8k
250	2	69	75	80	78	76	74	73	66
315	4	64	75	77	70	60	63	63	51
355	4	65	68	75	73	73	70	59	53
400	4	66	73	79	77	73	72	68	61
450	4	71	76	84	83	83	80	77	65
500	4	73	82	87	84	84	82	76	68
560	4	75	83	90	87	85	85	82	73

## Performance Curve

355 - 560 dia - 6 Pole - 1 & 3 Phase

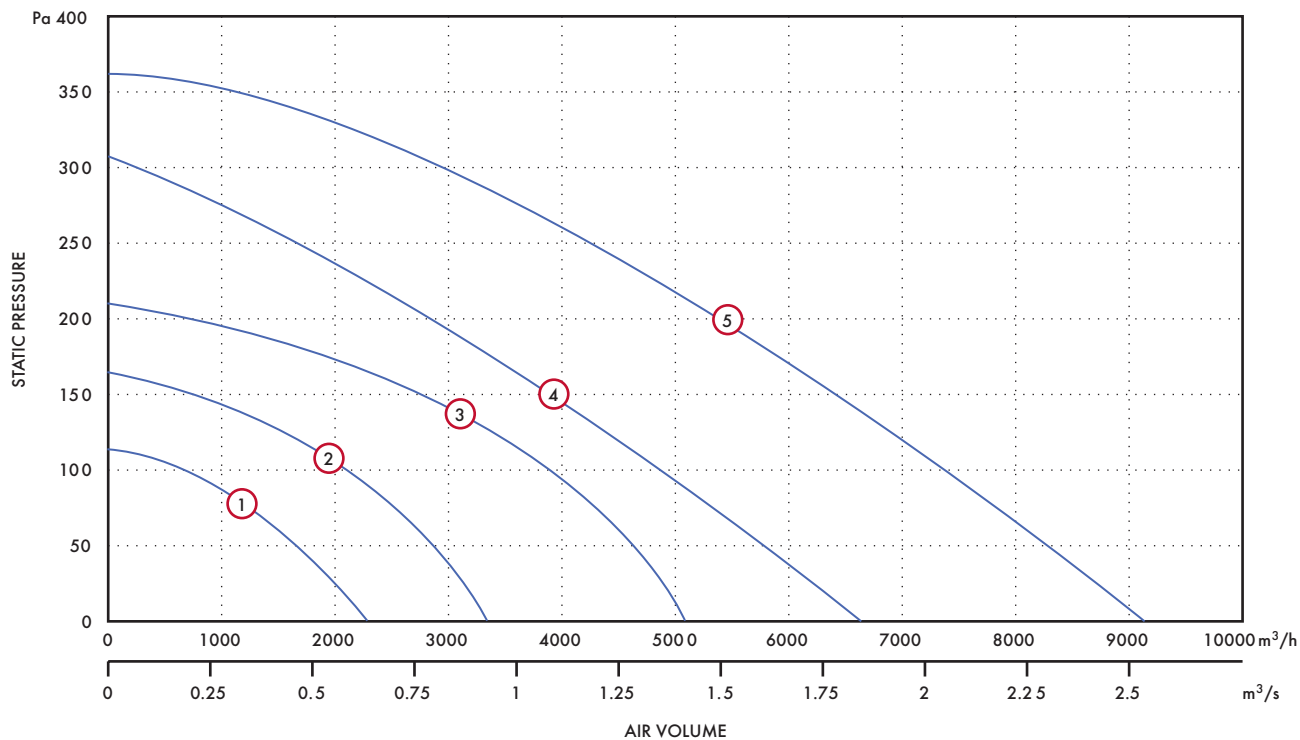

## Performance Guide

Dia.	Phase	Stock Model	Pole	rpm	Curve Ref	m³/s at Pa						Motor kW	S.C. Amps	F.L.C. Amps	dBA @ 3m
						0	25	50	100	150	200				
355	1	RMH35516	6	920	1	0.61	0.55	0.47	0.16			0.09	1.1	0.44	47
355	3	RMH35536	6	920	1	0.61	0.55	0.47	0.16			0.1	0.57	0.25	47
450	1	RMH45016	6	920	3	1.42	1.35	1.29	1.07	0.73	0.15	0.4	5.1	2.3	55
500	1	RMH50016	6	910	4	1.83	1.72	1.60	1.34	1.05	0.73	0.43	4.1	2.1	60
560	1	RMH56016	6	870	5	2.56	2.43	2.32	2.07	1.82	1.54	0.68	7.1	3.3	61
560	3	RMH56036	6	870	5	2.56	2.43	2.32	2.07	1.82	1.54	0.67	4.1	1.55	61

## Sound Power Level Spectra dB (re 10<sup>-12</sup>Watts)

Diameter	Pole	63	125	250	500	1k	2k	4k	8k
355	6	59	60	66	63	63	61	50	46
450	6	65	67	75	73	72	70	68	55
500	6	67	73	77	75	75	72	67	59
560	6	68	73	80	78	76	75	73	64

## Accessories Dimensions (mm)

### Roof Attenuators

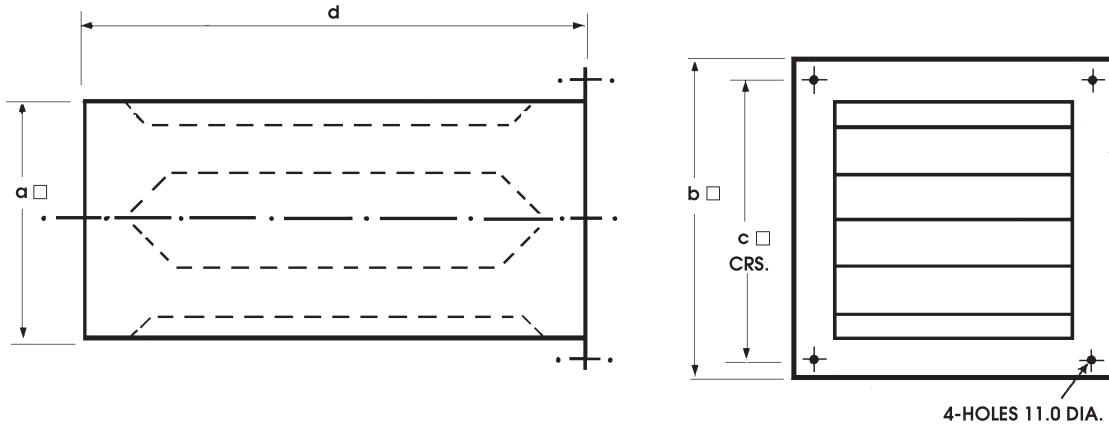

Stock Ref	a □	b □	c □	d	kg approx	Face Area m <sup>2</sup>	Curve Ref
10520315	395	495	445	600	18	0.156	2
10520400	495	595	545	600	22	0.245	1
10520500	645	745	695	600	31	0.416	1
10520630	785	885	835	600	44	0.616	2
10521315	395	495	445	900	21	0.156	2
10521400	495	595	545	900	28	0.245	1
10521500	645	745	695	900	39	0.416	1
10521630	785	885	835	900	52	0.616	2
10522315	395	495	445	1200	25	0.156	2
10522400	495	595	545	1200	35	0.245	1
10522500	645	745	695	1200	48	0.416	1
10522630	785	885	835	1200	61	0.616	2

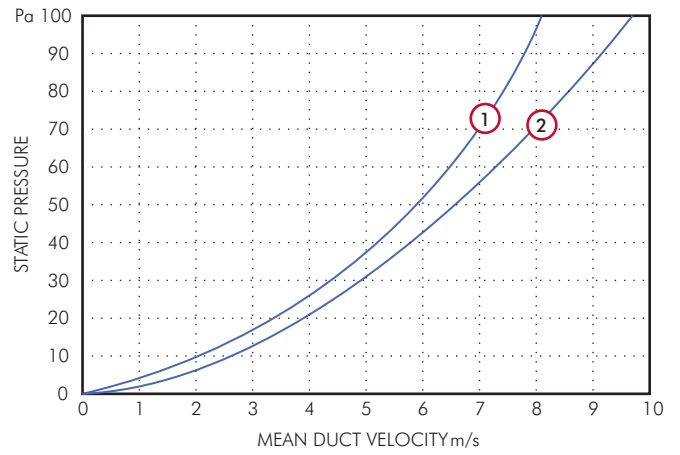

### Roof Attenuator, Insertion Losses

Stock Ref.	Length mm	63	125	250	500	1k	2k	4k	8k
105 20 315	600	2	4	9	16	20	22	18	14
105 20 400	600	2	4	8	15	18	20	17	13
105 20 500	600	2	4	9	16	20	22	18	14
105 20 630	600	2	4	8	15	18	20	17	13
105 21 315	900	3	6	13	22	30	31	22	17
105 21 400	900	2	6	12	20	25	27	20	16
105 21 500	900	3	6	13	22	30	31	22	17
105 21 630	900	2	6	12	20	25	27	20	16
105 22 315	1200	4	9	16	28	34	35	23	19
105 22 400	1200	4	8	15	26	32	33	21	18
105 22 500	1200	4	9	16	28	34	35	23	19
105 22 630	1200	4	8	15	26	32	33	21	18

## Accessories



\*eDemand Controller

Fan	Electronic Controller	Auto Transformer	Starter	Overload	Voltage Control	3 Phase Inverter
Stock Ref	Stock Ref	Stock Ref	Stock Ref	Stock Ref	Stock Ref	Stock Ref
RMH25012	W10303102M	10314103	444744	444699	444164	-
RMH31514	W10303102M	10314103	444744	444699	444164	-
RMH35514A	SC5030TK	10314103	444744	444701	444164	-
RMH35516	W10303102M	10314103	444744	444698	444164	-
RMH35536	-	10314301	444747	444697	444166	444172
RMH40014A	SC5030TK	10314103	444744	444702	444164	-
RMH40034A	-	10314301	444747	444700	444166	444172
RMH45014A	SC5060TK	10314105	444744	444703	444164	-
RMH45034B	-	10314304	444747	444701	444166	444172
RMH45016	SC5030TK	10314103	444744	444702	444164	-
RMH50014A	SC5010TK	10314113	444744	444705	-	-
RMH50034A	-	10314304	444747	444702	444166	444173
RMH50016	SC5030TK	10314103	444744	444701	444164	-
RMH56034A	-	10314307	444747	444703	444166	444173
RMH56016	SC5060TK	10314105	444744	444702	444164	-
RMH56036A	-	10314304	444744	444702	444166	444172

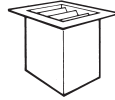

Roof Attenuators

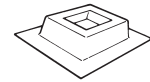

Purlin

Boxes

Size	Roof Attenuators			Purlin Boxes
	600mm †	900mm †	1200mm †	
	Stock Ref	Stock Ref	Stock Ref	Stock Ref
315	10520315	10521315	10522315	10516315
355	10520315	10521315	10522315	10516315
400	10520400A	10521400	10522400	10516400
450	10520400A	10521400	10522400	10516400
500	10520500	10521500	10522500	10516500
560	10520500	10521500	10522500	10516500
630	10520630	10521630	10522630	10516630

† Air Operated Shutters and manual/motorisable Shutters are not suitable for use in combination with Roof Attenuators. Special manual/motorisable Shutters can be fitted to the bottom of the Roof Attenuator - Supplied by others

\* For full range of speed controller options, see Accessories & Controllers Section



# Lo-Carbon Energy Saver MX Roof Fans (MX)

- Reduces your carbon footprint
- Three stylish diagonal discharge models
- 70% energy savings
- Customised performance from 2200m<sup>3</sup>/h to 6700m<sup>3</sup>/h
- Can be remotely monitored
- Designed for easy inspection access for cleaning, maintenance or servicing
- Long life DC motor

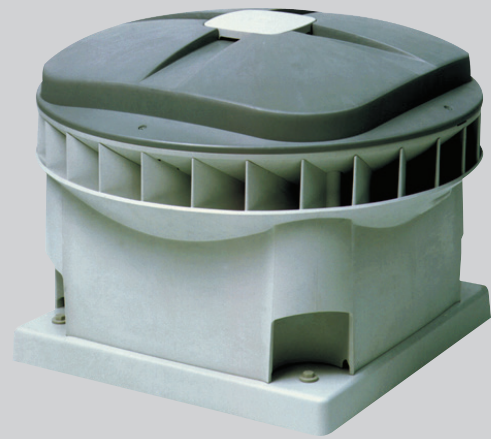

The Lo-Carbon MX Roof Range offers longer life, lower maintenance and energy savings to a variety of commercial and industrial applications. Three stylish diagonal discharge models MX10, MX20 and MX30 offer customised performances up to 5,500m<sup>3</sup>/h.

The units are moulded in tough recyclable material, fully UV stabilised and are suitable for arduous external conditions. The design features a mixed flow impeller with the motor out of the airstream and a slanted diagonal discharge pattern which creates an upwardly spiralling discharge pattern. Suitable for horizontal mounting only (max. of 3° from horizontal).

## Motors

At the heart of the range is the latest Lo-Carbon energy saver DC technology, eliminating the need for expensive transformer controllers to achieve customised duties. Due to the Lo-Carbon DC design, the motors run cooler, prolonging the life of the bearings and motor lubricants. The motor is integral to the mixed flow impeller and is designed for ambient duct temperatures up to +80°C.

MX motors are up to 80% efficient in converting energy into rotation, providing large energy savings throughout the speed range. They are also precisely controllable, typically offering energy savings of 40-60% compared with AC equivalents.

## On Board Control

The electronics in the Lo-Carbon MX range offer the possibility of setting any working point/speed whenever required without a controller. The standard unit is ready to connect to a single phase electrical supply. However, an ideal working point can be set either at the factory or on site to suit a system duty. If the system resistance or volume requirement changes, the fan duty can be re-programmed to meet this new performance on site. Traditional AC products are tied to 4, 6 and 8 pole models and costly transformers - the Lo-Carbon MX is simply set up at the desired speed and, if required, can be controlled using inexpensive switches connected by four core low voltage wire. The Lo-Carbon DC system can be controlled down

to much lower speeds than AC motors providing very quiet performance when required.

## Maintenance

Vent-Axia Lo-Carbon MX units have a built in fault diagnosis system. An installation of several units can be interconnected using simple two core wire to form a BUS network for flexible remote maintenance monitoring tailored to meet your needs. Vent-Axia MX maintenance software is available, the installation can be used on a laptop/PC. Alternatively a hand held diagnostics/programmer is available for on site use. Lo-Carbon MX units have their own encoded signature, allowing ease of identification and full performance history access.

Vent-Axia's Lo-Carbon MX range is designed for easy inspection access for cleaning. Four screws secure the main cover. Disconnect the internal mains plug and four bolts release the chassis holding the fan/motor assembly and the electronic module.

The Lo-Carbon MX range is constructed from fully recyclable plastics. The diagonal vortex discharge pattern throws air and sound upwards and away from the roof surface.

## Lo-Carbon MX Sectional View

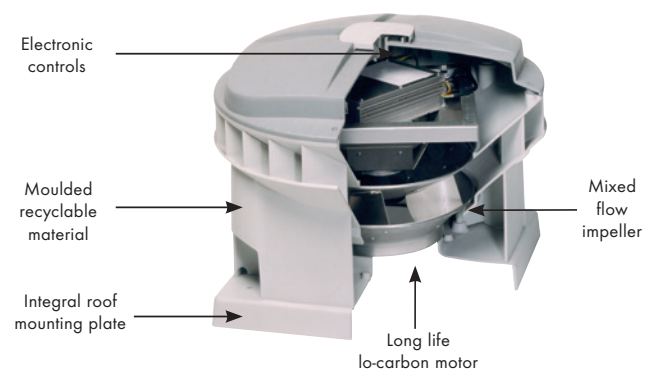

# Performance

## MX 10/10

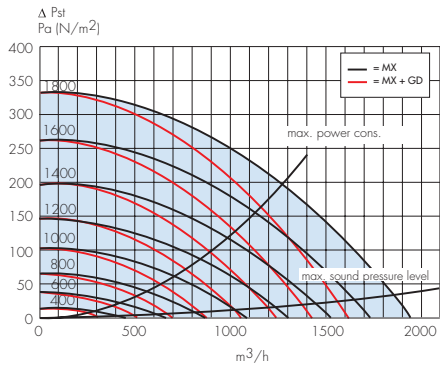

## MX 20/10

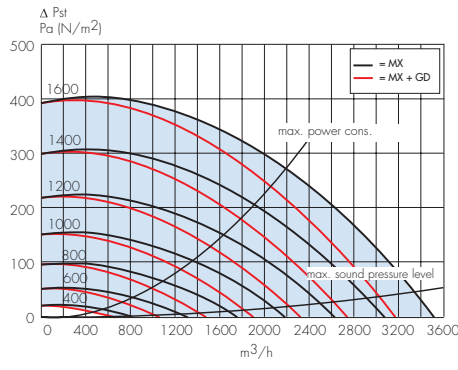

## MX 30/20

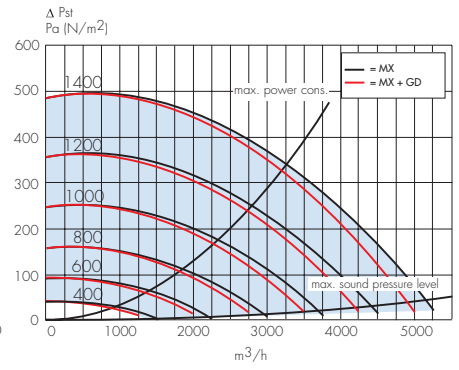

MX 10/10 - Stock Ref No: 45 46 12

max. 2000 rpm/2200 m<sup>3</sup>/h

Speed rpm	Current A	Power Watts	del. dB(A)	Sound level	
				intake dB(A)	intake* dB(A)
1800	0.76	174	57	72	63
1600	0.55	125	54	70	61
1400	0.39	87	50	66	58
1200	0.26	60	46	63	55
1000	0.17	39	41	58	51
800	0.12	27	36	56	49
600	0.09	19	30	49	42
400	0.07	12	24	41	35

\* with GD silencer

max. 2000 rpm/2200 m<sup>3</sup>/h

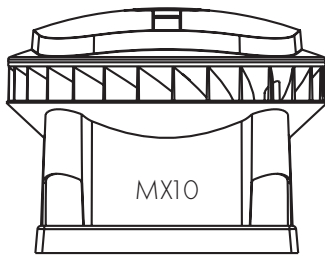

MX 20/10 - Stock Ref No: 45 46 13

max. 1600 rpm/3600 m<sup>3</sup>/h

Speed rpm	Current A	Power Watts	del. dB(A)	Sound level	
				intake dB(A)	intake* dB(A)
1600	1.8	409	62	77	64
1400	1.16	266	58	74	62
1200	0.73	169	53	69	57
1000	0.44	100	48	65	54
800	0.25	57	42	59	49
600	0.14	31	36	55	45
400	0.09	17	28	48	39

\* with GD silencer

max. 1600 rpm/3600 m<sup>3</sup>/h

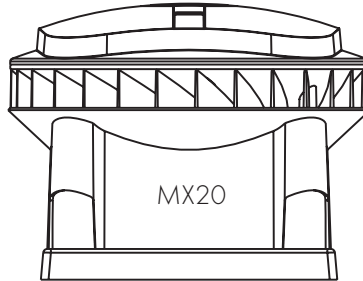

MX 30/20 - Stock Ref No: 45 46 14

max. 1500 rpm/6700 m<sup>3</sup>/h

Speed rpm	Current A	Power Watts	del. dB(A)	Sound level	
				intake dB(A)	intake* dB(A)
1200	1.9	433	60	75	65
1000	1.1	250	56	71	61
800	0.59	135	50	66	56
600	0.28	64	43	60	50
400	0.11	24	34	51	42

\* with GD silencer

max. 1500 rpm/6700 m<sup>3</sup>/h

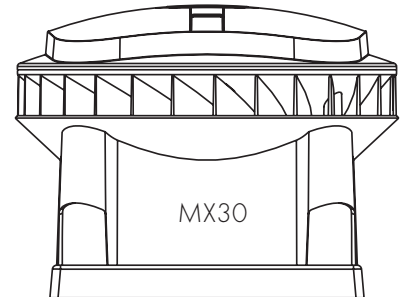

## Fan Dimensions (mm)

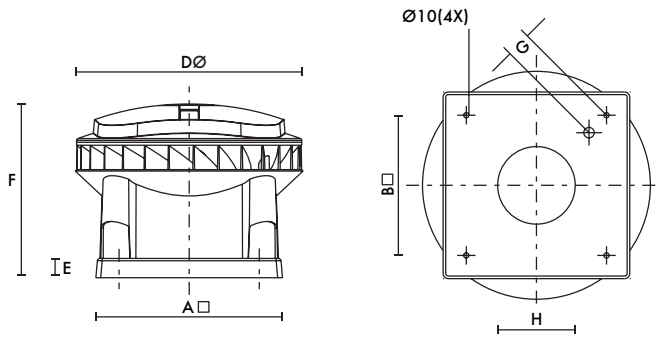

Model	MX10/10	MX20/10	MX30/20
A □	460	580	665
B □	330	450	535
D Ø	575	708	863
E	60	60	60
F	473	540	601
G	44	48	64
H	196	241	302

## Upstand Dimensions

Model	A □	B □	C □
MX 10/10	275	375	330
MX 20/10	400	500	450
MX 30/20	485	585	535

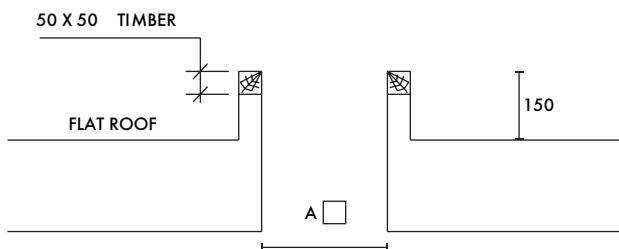
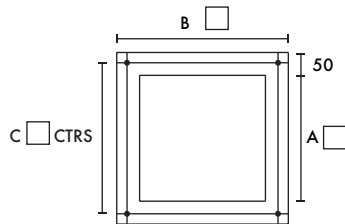

## LTG Temperature Sensitive Speed Controller

LTG  
DIMENSIONAL  
DETAILS

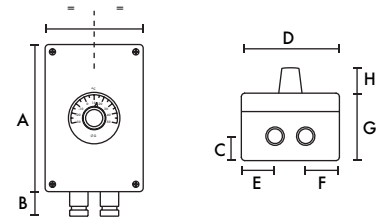

## VG 31 Multi Unit Controller

VG 31  
DIMENSIONAL  
DETAILS

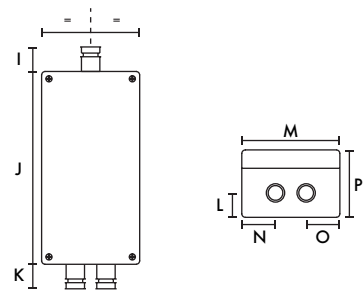

The LTG is an air temperature sensitive speed controller, which can be set between 20°C and 50°C. The controller is suitable for controlling up to 5 MX units when used in conjunction with a VG31 Multi Unit Controller.

The fan will run at a minimum speed until the air temperature reaches the set point on the controller. When the set point is reached the controller will gradually increase the speed of the fan until the fan has reached its maximum speed. The fan speed gradient (min/max bandwidth), can be set from between 0.5°C and 10°C by adjusting a potentiometer within the controller housing. A probe fixed within the fan housing measures the air temperature.

A	120
B	28
C	28
D	80
E	27.5
F	27.5
G	60
H	20
I	20
J	180
K	20
L	20
M	80
N	27.5
O	27.5
P	60

## Lo-Carbon MX Roof Range Alternative Management Controls

Easy to monitor and maintain

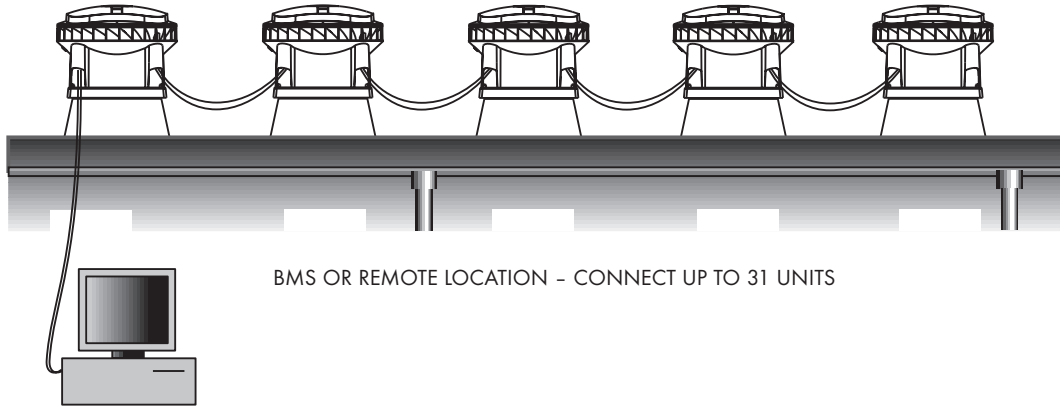

## Lo-Carbon MX Roof Range Fan Controls



### SAG 0-2

2-step controller. Step 1 and 2 are separately adjustable  
 Stock Ref  
**454616**



### SAG 0-5

5-step controller adjustable maximum capacity  
 Stock Ref  
**454617**



### SAG 0-M

Infinitely variable controller adjustable maximum capacity  
 Stock Ref  
**454618**

## Accessories

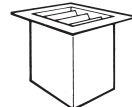
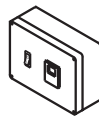

Model	SAG 0-2	SAG 0-5	SAG 0-M	DNG 31	ITG	600mm	900mm	1200mm
Ref	Stock Ref	Stock Ref	Stock Ref	Stock Ref	Stock Ref	Stock Ref	Stock Ref	Stock Ref
MX 10/10	454616	454617	454618	456930	456931	-	-	-
MX 20/10	454616	454617	454618	456930	456931	10520315	10521315	10522315
MX 30/20	454616	454617	454618	456930	456931	-	-	-



# Accessories & Controllers - Non Residential



Whether you are looking for ducting, controllers or accessories this is the section where you can find the details.

Within each product area you can find product specific accessories, here you can find common items which fit a range of fans.

This simple easy to use reference section provides you with all the details you need to complete the selection and specification of your project.

**Vent-Axia®**



eDemand Controllers

P3-P:10

---



Air Duct Heater

P9-P10

---



Speed Controllers & Accessories

P11-P27

---

# eDemand Electronic Voltage Controller

- Demand ventilation control for A/C speed controllable fans
- Quick start-up by pre-programmed modes
- IP54 Rated
- Total motor protection using thermistor connection
- LCD multi function display
- Menu language - English, German, French, Italian
- 2 x analogue input for sensors (0-10V - separate power supply required, 0-20mA)
- CO<sub>2</sub> Control
- Temperature control
- Constant pressure control
- Manual remote speed adjuster (0-20 mA)
- Min/Max speed limitation - Volume range set point adjustment



## Equipment/Function

- Mains switch with by-pass function
- Pin protection, to save user settings
- Quick start up by pre-programmed modes
- Max environmental conditions 40 Deg C, 85% Humidity no condensation
- Readout events memory (checking Fault log)

## Technical

Line voltage 1~ 230V (-15% / + 10%) 50/60 Hz

Line Voltage 3~ 208V - 415V (-10%/+6%), 50/60 Hz

Stock Ref	444164	444165	444166	444167
Voltage	1 Phase	1 Phase	3 Phase	3 Phase
Rated current / A	6	10	5	10
Max. line fuse / A	10	16	10	16
Max. heat dissip. /W	20	40	25	50
Weight / kg	1.4	2.4	2.4	2.8

Interference emissions EN 61000-6-3 (unshielded motor cable)

Interference immunity EN 61000-6-2

For suitability check relevant fan accessory section

## Dimensions (mm)

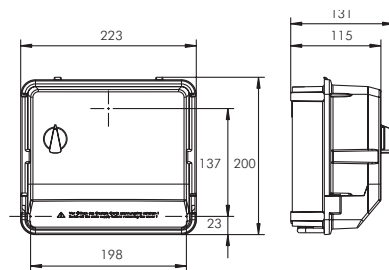

### 1 Phase 6 Amp

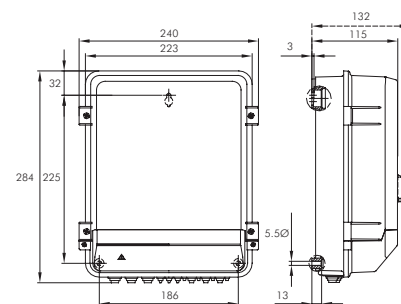

### 1 Phase 10 Amp

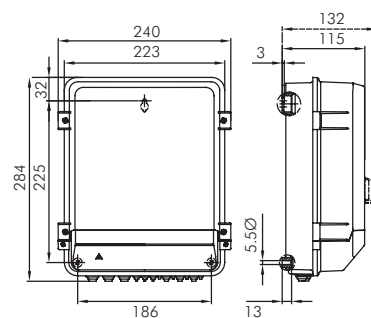

### 3 Phase 5/10 /15 Amp

# eDemand Frequency Inverter 3~

- Demand ventilation control for A/C speed controllable Fans
- Quick start-up by pre-programmed modes
- IP54 Rated
- Total motor protection using thermistor connection
- LCD multi function display
- Menu language - English, German, French, Italian
- 2 x analogue input for sensors (0-10V - separate power supply required, 0-20mA)
- CO<sub>2</sub> Control
- Temperature control
- Constant pressure control
- Manual remote speed adjuster (0-20 mA)
- Min/Max speed limitation - Volume range set point adjustment



## Equipment/Function

- Pin protection, to save user settings
- Quick start up by pre-programmed modes
- Integrated SINEFILTER
- Max environmental conditions 40 Deg C, 85% Humidity no condensation
- Readout events memory (checking Fault log)
- Speed control of fans without additional (electromagnetic) motor noise
- Integrated SINEFILTER between phase to phase & phase to ground
- Parallel operation of fans, no risk of motor damage (screened motor cables are not required)
- Active power factor adjustment for sinusoidal input current
- Integrated process controller (PID free programmable)

## Technical

Line voltage 3 ~ 208...480 V (-15 % / +10 %), 50/60 Hz

Stock Ref	444172	444173	444174	444175	444176
Rated current / A	2.5	5	8	14	18
Max. line fuse / A	6	10	10	16	20
Max. heat dissip. /W	50	100	150	310	400
Weight / kg	3.3	7.2	7.9	8.7	9.1

Max output frequency 100 Hz

Clock frequency 16 Hz

Interference emissions EN 61000-6-3 (unshielded motor cable)

Interference immunity EN 61000-6-2

For suitability check relevant fan accessory section

## Dimensions (mm)

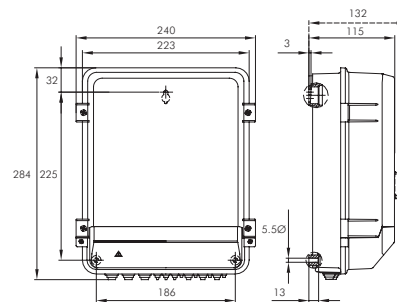

2.5 Amps

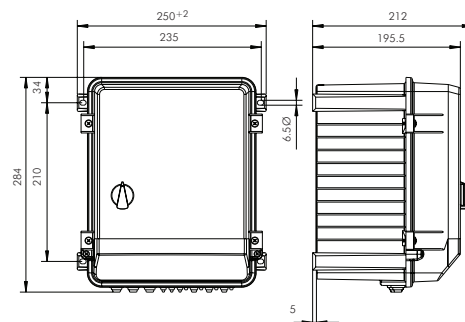

5/8/14/18 Amps



# eDemand Frequency Inverter 1<sup>~</sup>

- Demand ventilation control for A/C speed controllable Fans
- Quick start-up by pre-programmed modes
- IP54 Rated
- Total motor protection using thermistor connection
- LCD multi function display
- Menu language - English, German, French, Italian
- 2 x analogue input for sensors (0-10V - separate power supply required, 0-20mA)
- CO<sub>2</sub> Control
- Temperature control
- Constant pressure control
- Manual remote speed adjuster (0-20 mA)
- Min/Max speed limitation - Volume range set point adjustment



## Equipment/Function

- Pin protection, to save user settings
- Quick start up by pre-programmed modes
- Integrated SINEFILTER
- Max environmental conditions 35 Deg C, 85% Humidity no condensation
- Readout events memory (checking Fault log)
- Speed control of fans without additional (electromagnetic) motor noise
- Parallel operation of fans, no risk of motor damage (screened motor cables are not required)
- Active power factor adjustment for sinusoidal input current
- Integrated process controller (PID free programmable)

## Technical

Line voltage 1<sup>~</sup> 208 ... 277 V (-10 % / +10 %), 50/60 Hz

Stock Ref	444169	444170	444171
Voltage	1 Phase	1 Phase	1 Phase
Rated current / A	4	6	10
Input rated Current/ A	3.85	5.85	-
Max. line fuse / A	6	10	16
Max. heat dissip. /W	57	102	130
Weight / kg	3.4	5.7	6.8

Max output frequency 100 Hz

Clock frequency 16 Hz

Interference emissions EN 61000-6-3 (unshielded motor cable)

Interference immunity EN 61000-6-2

For suitability check relevant fan accessory section

## Dimensions (mm)

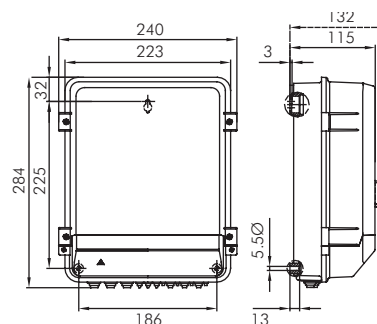

4 Amps

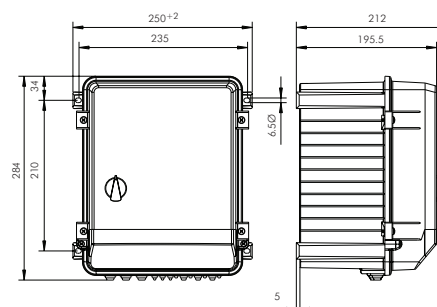

6/10 Amps

# eDemand Auto Changeover Panels

- IP54 Enclosure
- eDemand compatible
- Single & Three Phase models
- Adjustable duty/share timer
- Automatic changeover (Fan Fail)
- Fan failure alarm contacts



Offering Demand Ventilation control for the wide range of standard AC speed controllable Twin fans, these changeover panels have been designed to complement the new range of eDemand Controllers and are fully compatible.

Speed control input is suitable for use with the following eDemand Controller ranges:

- Single & Three Phase electronic speed controllers
- Single & Three Phase inverters
- Single to Three Phase inverter

---

## Models

Model	Stock Ref
Three Phase 16 Amp	444179
Single Phase 10 Amp	444180

---

## Dimensions (mm)

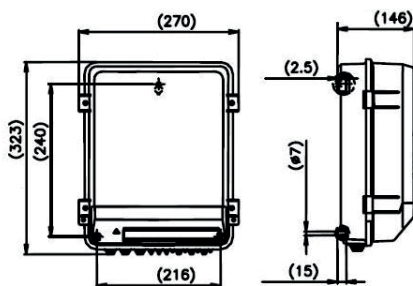

# Connection Diagrams

Single Phase Electronic for 444164 & 444165

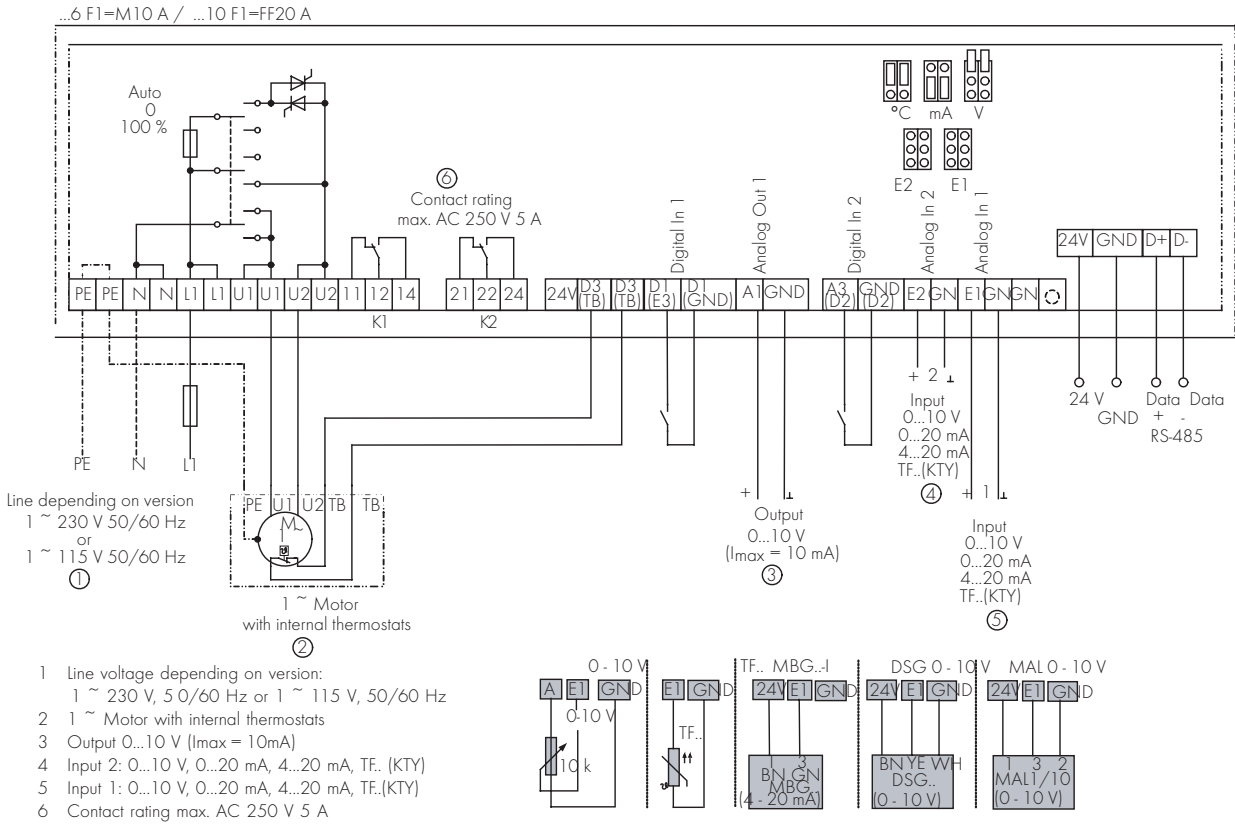

Three Phase Electronic for 444166, 444167

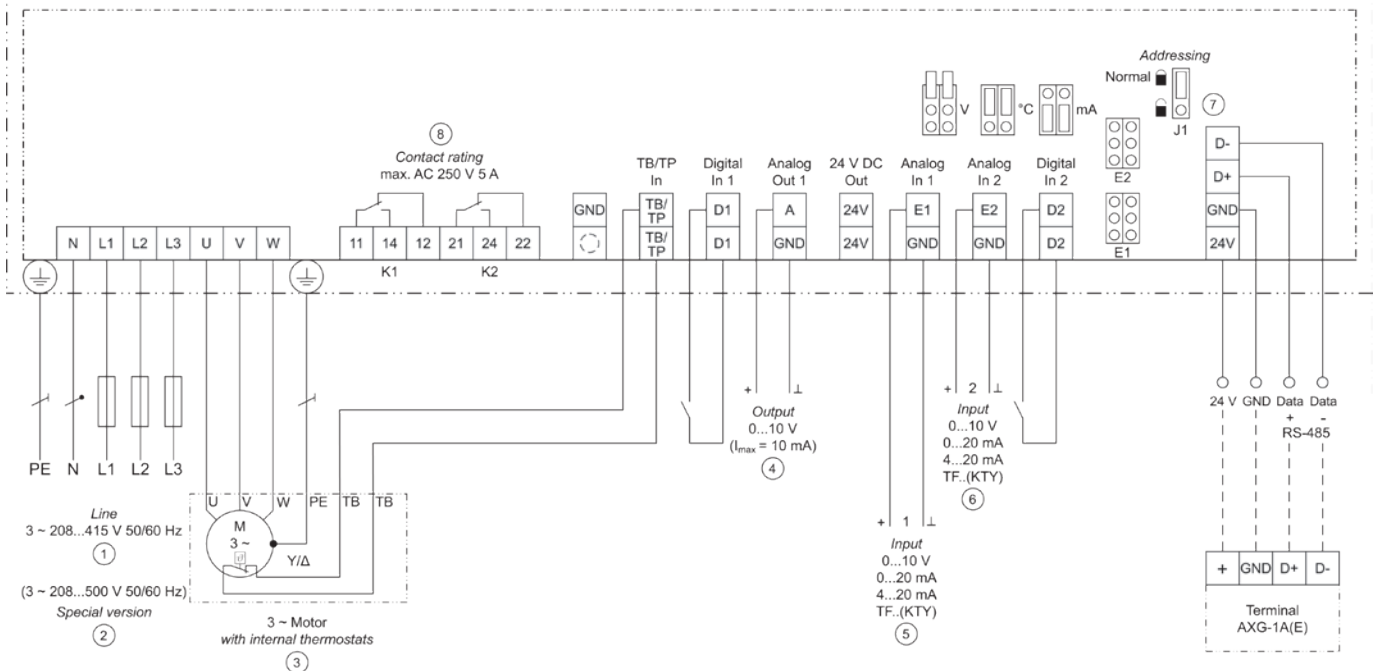

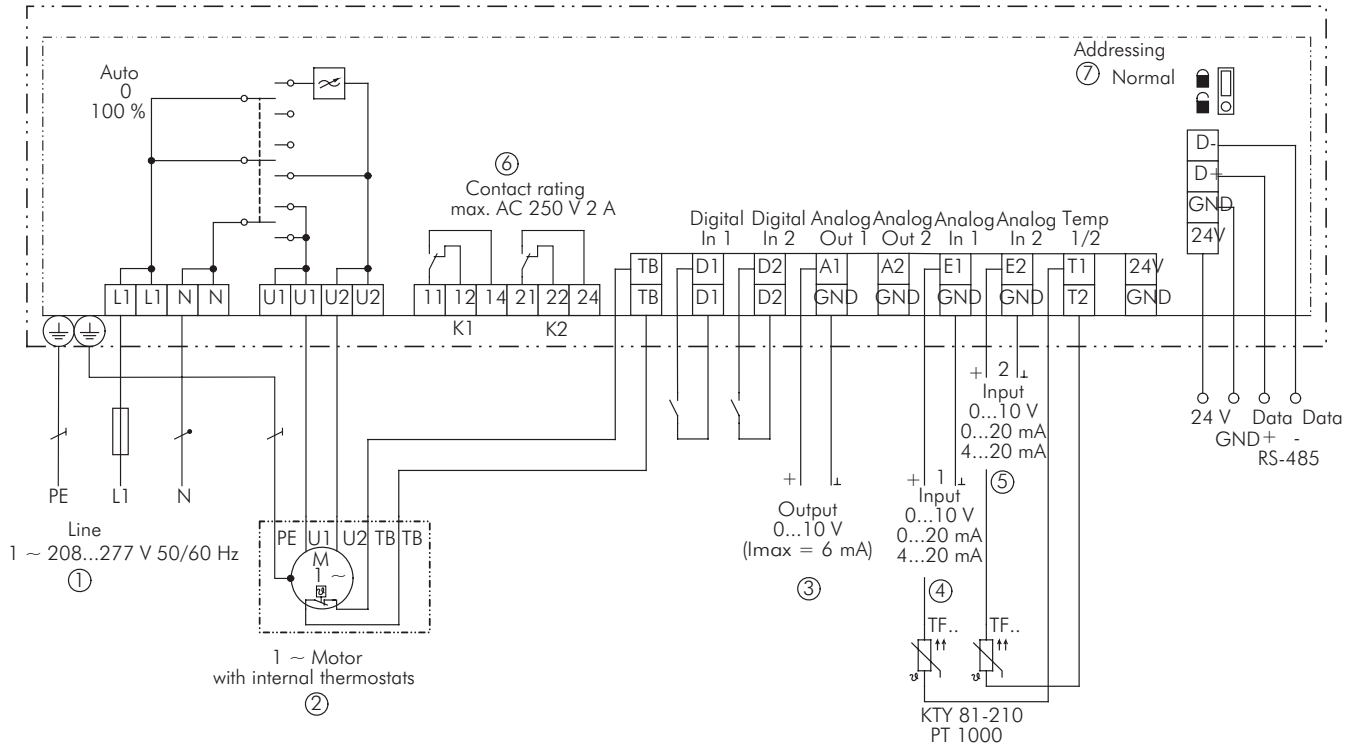

- 1 Line 1 ~ 208...277 V, 50/60 Hz
- 2 1 ~ Motor with internal thermostats
- 3 Output 0...10 V (I<sub>max</sub> = 6 mA)
- 4 Input 1: 0...10 V, 0...20 mA, 4...20 mA, TF.. (KTY81-210), PT1000

- 5 Input 2: 0...10 V, 0...20 mA, 4...20 mA, TF.. (KTY81-210), PT1000
- 6 Contact rating max. 2A / 250 V AC
- 7 Addressing, normal lock closed

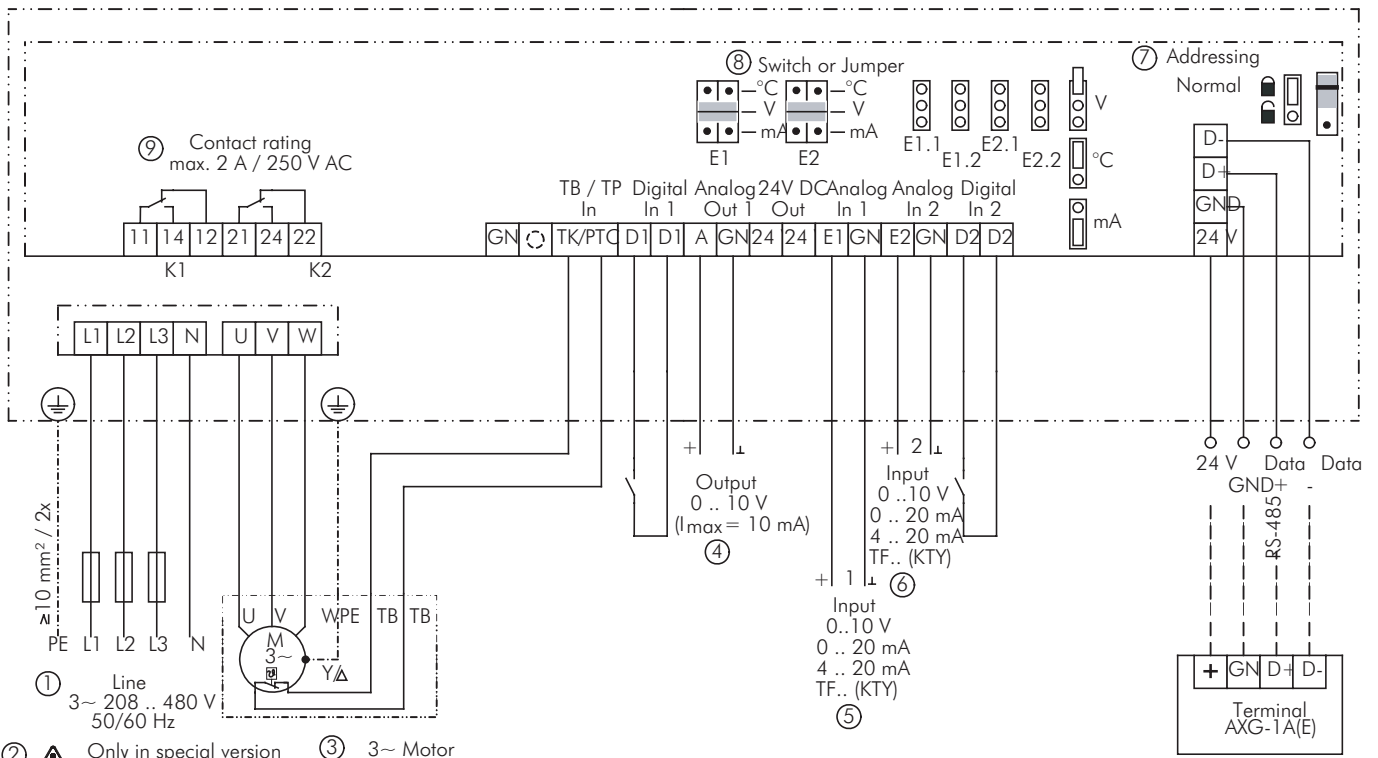

- ② ⚠ Only in special version suitable for IT network!
- ③ 3~ Motor with internal thermostats

- 1 Line 3 ~ 208...480 V, 50/60 Hz
- 2 Only in special version suitable for IT network!
- 3 3 ~ Motor with internal thermostats
- 4 Output 0...10 V (I<sub>max</sub> = 10 mA)
- 5 Input 1: 0...10 V, 0...20 mA, 4...20 mA, TF.. (KTY)
- 6 Input 2: 0...10 V, 0...20 mA, 4...20 mA, TF.. (KTY)
- 7 Addressing, normal lock closed
- 8 Switch or jumper depending on version

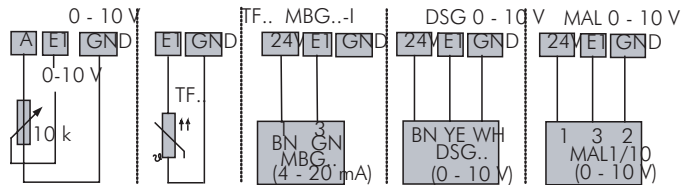

# AirTrack Duct Air Heaters

- Supply and extract fan outputs
- Combined temperature and airflow sensor
- Run on timer
- Solid state switching - no mechanical switching breakdown
- Indicators for control status
- High temperature limit and manual reset
- Separate supply and extract fan outputs for heaters over 150mm dia

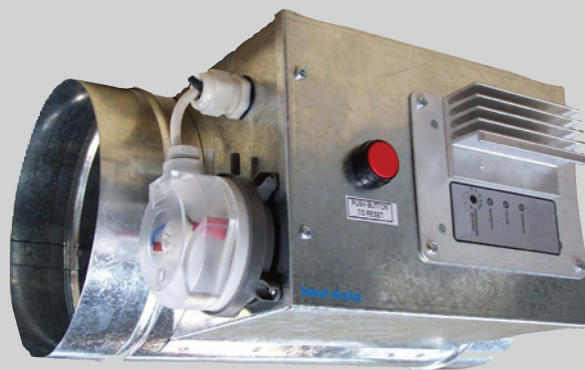

The Vent-Axia range of sheathed element air duct heaters with built in control system provide a safe method of air heating which is economical to install and operate.

## Construction

Circular Duct Air Heaters comprise of electric resistance elements, mounted in a pre-galvanised steel casing. Elements consist of a nickel/chromium resistance wire, spirally wound, insulated by compacted magnesium oxide powder and fitted within a stainless steel tube. The ends of each element are sealed with silicone rubber. Elements are return bent and mounted in the terminal box with airtight fixing glands.

Standard terminal boxes are made from pre-galvanised sheet steel, 25mm conduit holes and earth stud are provided. The terminal boxes conform to IP30.

Every heater is fitted with a high temperature safety cut out operating at 120°C complete with push button manual reset.

Available in 100, 125, 150, 200, 250, 315, 400 and 500mm diameter sizes. The air velocity across the heater elements must be greater than 2m/s and installed a minimum distance of one metre from the exhaust outlet of the fan unit.

## Mounting

Heaters can be mounted in any position, vertical or horizontal. Care should be taken to ensure the cut out remains operational.

## Controls

The Vent-Axia range of duct heaters with built-in controls are designed to be cost effective and space saving whilst maintaining the features normally associated with larger control panels.

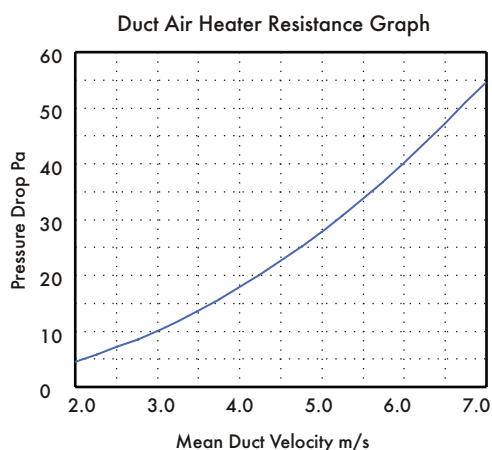

### Duct Air Temperature Rise

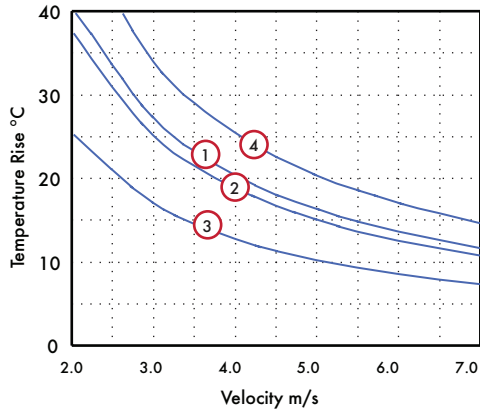

- ① 10531125T1 (1.25kW)      ③ 10531200T1 (2kW)
- ② 10531100T1 (0.75kW)    ④ 10531200T1 (4 kW)
- 10531150T1 (1.66kW)

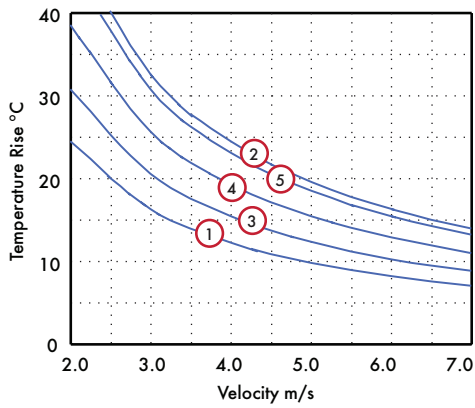

- ① 10531250T1 (3kW)      ④ 10531315T1 (8 kW)
- ② 10531250T1 (6kW)      ⑤ 10531315T3 (9kW)
- ③ 10531315T1 (4kW)

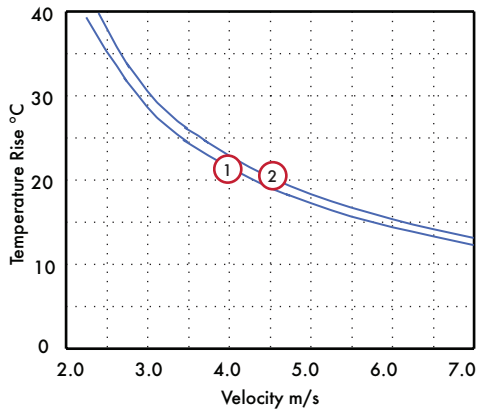

- ① 10531400T3 (12kW)
- ② 10531500T3 (21kW)

### Dimensions (mm)

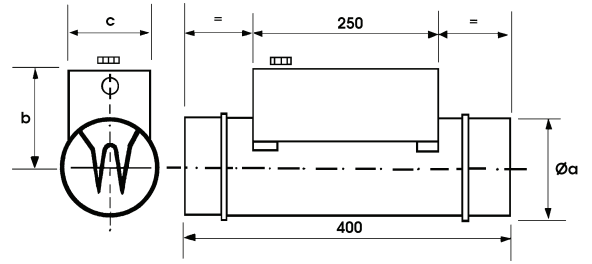

Stock Ref	Øa	b	c	kg
10531100T1	100	160	117	3
10531125T1	125	160	117	3.8
10531150T1	150	160	117	4
10531200T1	200	160	117	6
10531250T1	250	160	117	7.5
10531315T1	315	160	117	8.2
10531315T3	315	160	117	8.5
10531400T3	400	160	117	9.2
10531500T3	500	160	117	10

# Heat Exchange Unit

- Stand alone heat exchanger unit
- Up to 70% efficiency
- 200, 250 and 315 mm spigot connections available
- Polymeric construction



## Heat Exchange Unit

A 'stand alone' heat exchange module which will transfer up to 70% of the outgoing heat to incoming air. Polymeric construction with spigots to suit 315mm flexible ductwork. Module accessible for routine cleaning. Condensate outlet provided. Ideal for use in air conditioned environments. The Heat Exchanger works at the same high efficiency, automatically keeping a cool room cool.

By transferring heat from the extracted stale air, fresh pre-heated air is supplied to the room from outside, maintaining oxygen levels and preventing stuffiness. Maximum operating temperature 0°C to 70°C. (Weight 9kg)

## Heat Exchange Resistance Graph

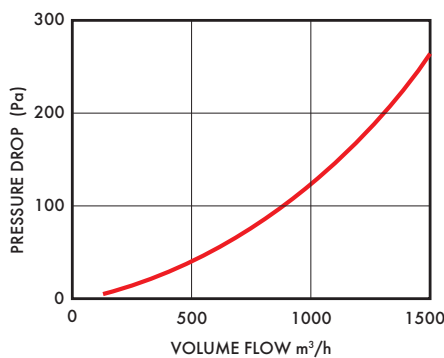

## Thermal Efficiency Graph

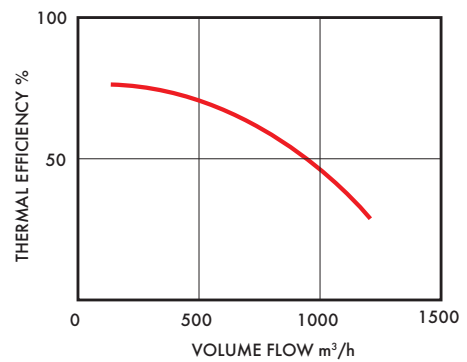

### WARNING

Both airflows to be subjected to the same conditions (ie. negative or positive pressure)  
Maximum differential pressure must not exceed 150Pa.

## Typical Installation

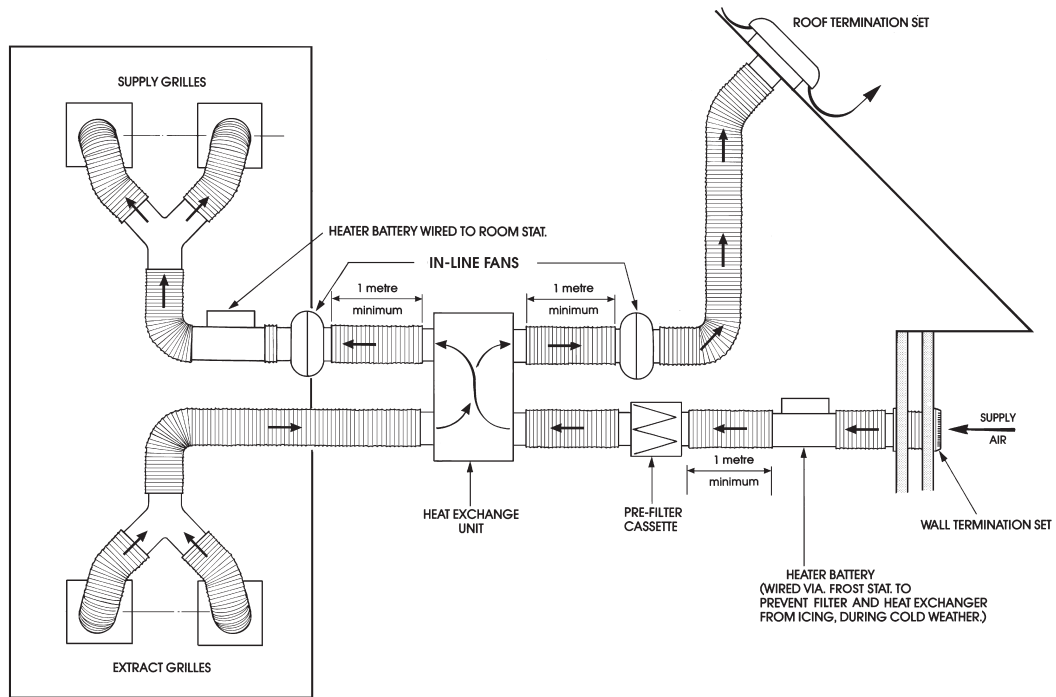

## Dimensions (mm)

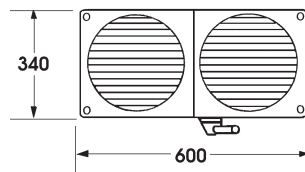
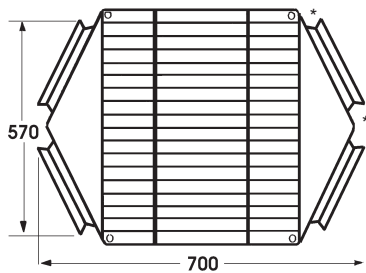

Dia.	Stock Ref	Weight
315	10538290	9 kg

\*Foil ring to take up difference.



# Electronic Fan Speed Controller with TK

- Wide power supply range (110–240 VAC/50–60 Hz)
- Automatic supply voltage detection
- Adjustable stepless output voltage
- 230 VAC alarm output
- TK monitoring for thermal motor protection
- Contacts for remote on/off switching
- Adjustable minimum and maximum speed limits
- Overheating motor protection
- Kick start (default) or soft start
- Illuminated on/off switch
- Run and fault detection LED indication



The SC5000TK range of electronic speed controllers regulate the speed of single-phase (110–240 VAC/50–60 Hz) voltage controllable motors by varying the supplied voltage. These controllers offer automatic power supply detection, thermal contacts (TK) for motor overheating protection, an alarm output, NO (open contact) and NC (closed contact) inputs for remote start/stop. The minimum and maximum speed limits are internally adjusted via trimmers. The range features an unregulated auxiliary output for connecting a dampers etc. There are two start-up modes - kick start and soft start, selectable via a jumper.

## Technical

Power supply, $U_s$	110–240 VAC / 50–60 Hz	
Regulated output	MIN–MAX ( $U_{min}$ – $U_{max}$ )	
Unregulated output	230 VAC / $I_{max}$ 2 A	
Minimum output	30–60 % of $U_s$	
Maximum output	70–100 % of $U_s$	
Alarm output	$I_{max}$ 0.5 A	
Kick start duration	8–10 s	
Protection	Motor overheating	
Protection standard	IP54 (according to EN 60529)	
Ambient conditions	Temperature	-20–35 °C
	Rel. humidity	5–95 % rH (non-condensing)
Maximum load	SC5030TK	Rated max, current, (A) 3.0
	SC5050TK	Rated max, current, (A) 5.0
	SC5060TK	Rated max, current, (A) 6.0
	SC5010TK	Rated max, current, (A) 10.0

## Operation Diagrams

### Control Curve

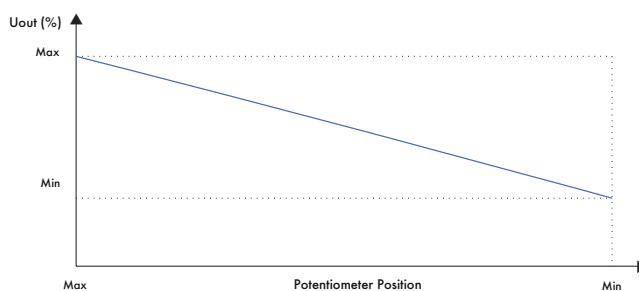

### Kick Start Mode

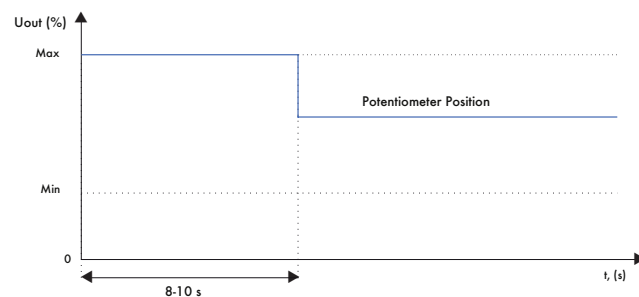

### Soft Start Mode

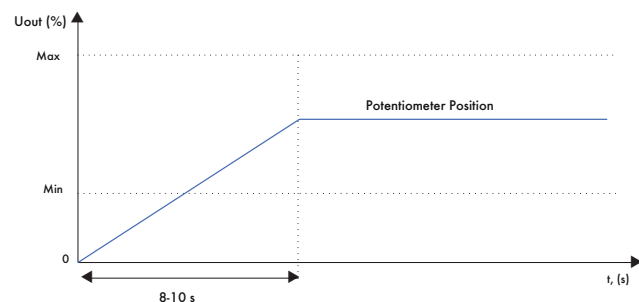

# Dimensions

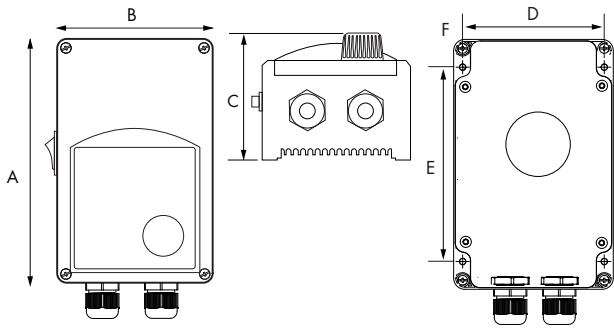

Stock Ref	A	B	C	D	E	ØF
SC5030TK	162	96	75	71	108.8	4.2
SC5050TK	162	96	93	71	108.8	4.2
SC5060TK	205	124	97	102	140	4.6
SC5010TK	205	124	97	102	140	4.6

## SC5030TK



1 Kick start selection jumper		Kick start is enabled
		Soft start is enabled
2 Minimum speed trimmer		Minimum speed limit pre set to 45%
3 Maximum speed trimmer		Maximum speed limit pre set to 100%

## SC5050TK, SC5060TK & SC5010TK



1 Kick start selection jumper		Kick start is enabled
		Soft start is enabled
2 Minimum speed trimmer		Minimum speed limit pre set to 45%
3 Maximum speed trimmer		Maximum speed limit pre set to 100%

# Electronic Fan Speed Controller Range

- Infinitely variable speed control
- Regulation from low to high speed
- Minimum speed adjustable
- Unregulated output (230 VAC/50–60 Hz)
- Flush or surface mounting
- Spring contact terminal block (1.5mm<sup>2</sup>)
- For indoor use only



The SC5000 range of electronic infinitely variable fan speed controllers allow you to manually adjust the speed of single phase AC fans by varying the motor voltage through phase angle control. The integrated switch enables or disables the motor.

## Technical

Stock Ref	Supply voltage	230 VAC / 50–60 Hz	
SC5001/ SC5030	Regulated output	U <sub>min</sub> –U <sub>s</sub>	
SC5001/ SC5030	Min. speed adjustment	80–180 VAC	
SC5001/ SC5030	Unregulated output	230VAC max 2.0A	
SC5001/ SC5030	Protection standard	Flush mounting	IP44 (according to EN 60529)
		Surface mounting	IP54 (according to EN 60529)
SC5001/ SC5030	Ambient conditions	Temperature	0–40 °C
		Rel. humidity	5–95 % rH (non-condensing)
SC5001	Maximum load	Rated max. current, [A 1.0 - 1.5	
SC5030		Rated max. current, [A 0.2 - 3.0	

## Low to High Speed

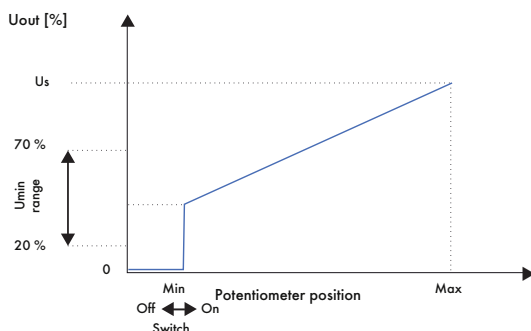

## Settings



- 1 Minimum speed adjustment
- Adjusts the min. speed ( preset to approx 40%)

## Dimensions

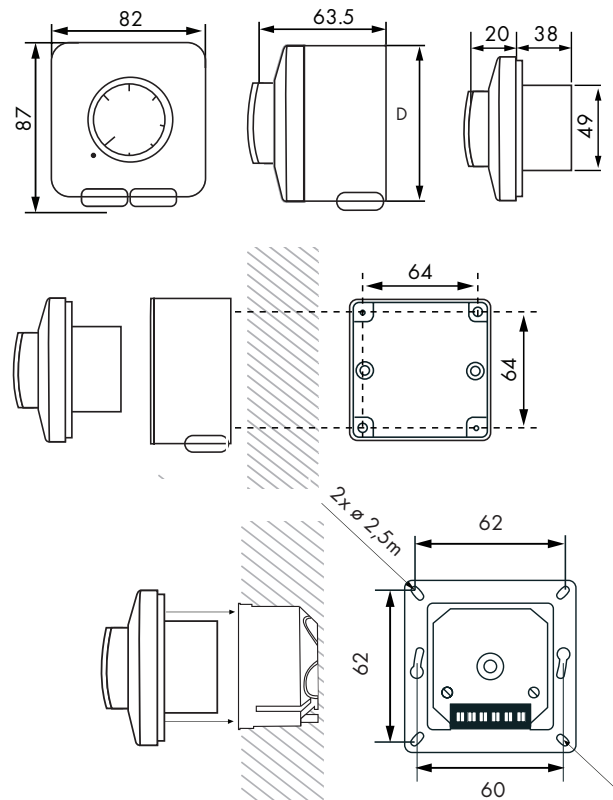

# Accessories



## Electronic Controllers

The 2.5 amp controller provides electronic motor speed control. On/Off with neon indicator, infinitely variable speed slider control, minimum speed presettable and optional sensor mode. Connections for use with external sensors are provided.

For ambient temperatures between 30-40°C the controller rating must be reduced by 2% for every 1°C above 30°C, eg. reduce by 10% at 35°C.

Stock Ref	Max. amps	Dimensions (mm) W x H x D	Weight kg
W10303102M	2.5	156 x 86 x 53	0.4



## Five Step Auto Transformers

Used in conjunction with speed controllable fans to provide 5 stepped speed without electronic motor 'hum and vibration'. Several fans can be connected to one transformer provided their combined load does not exceed the controller rating.

Single phase: 2.0, 3.5, 6.0, 7.5, 9.0 and 14 amp. Three phase: 1.0, 2.0, 4.0, 7.0 and 14 amp.

Rotary switch giving On/Off and five speeds.

Output voltages at 240V/1PH/50Hz

0, 65, 110, 135, 170 and 240 volts.

Output voltages at 415V/3PH/50Hz

0, 65, 110, 175, 285, 415 volts.

Neon indicator. Three phase units complete with terminals for remote on/off switch

## Multi-unit Speed Control

When more than one fan is required to be controlled by one Auto Transformer, then the total combined FLC of all the fan units must not exceed 90% of the controllers maximum rating and not more than 2 x the total SC. The TKs must be wired in series. Fans without TKs or in-built S.T.O.P must not be wired in multiples.

## Single Phase

Stock Ref	Max Peak Load Current	Dimensions (mm) H x W x D	Weight kg
10314102*	2.0	230 x 168 x 118	1.0
10314103*	3.5	230 x 168 x 118	4.6
10314105*	6.0	230 x 166 x 118	5.0
10314107*	7.5	284 x 240 x 132	6.2
10314113*	14.0	316 x 270 x 168	16.5

\*IP54 enclosures

## Three Phase

Stock Ref	Max Peak Load Current	Dimensions (mm) H x W x D	Weight kg
10314301*	1.0 amps	284 x 240 x 132	4.7
10314304†	4.0 amps	316 x 270 x 168	12.9
10314307†	7.0 amps	324 x 270 x 168	15.6
10314311†	14.0 amps	295 x 400 x 170	30.0

\*IP54 enclosure †IP21 enclosure

# Accessories



## Direct on-line and Star Delta starters

Suitable for all models. Push button Start/Stop. 240V contactor coil for single phase applications and three phase supplies where a neutral is present. 415V contactor coil for three phase supplies where a neutral is not present or required. Protection is given by an overload relay which is selected to match the load of the fan.

Enclosures are protected to IP65.

When ordered with the relevant sized Direct on Line or Star Delta starter the overloads are fitted within the starter.

## Overloads

Stock Ref	DOL Rating (Amps)	Star Delta Rating (Amps)
444696	0.16-0.25	-
444697	0.25-0.4	-
444698	0.4-0.63	-
444699	0.63-1.0	-
444700	1.0-1.6	-
444701	1.6-2.25	2.7-4.3
444702	2.5-4.0	4.3-6.9
444703	4.0-6.0	6.9-10
444704	5.5-8.0	9.5-13.8
444705	7-10	12-17
444706	10-13	17-22
444707	13-18	22-31
444708	18-25	31-43
444709	23-32	39-55

## DOL & Star Delta Starters

Stock Ref	Phase	DOL Rating (Amps)	Star Delta Rating (Amps)
444744	1	12	-
444745	1	25	-
444746	1	32	-
444747	3	12	-
444748	3	25	-
444749	3	32	-
444750	3	50	-
444842	-	-	21
444843	-	-	30

# Accessories



## Bag Filter Cassettes

Bag filter cassettes are available in a range of seven sizes. The synthetic filter medium is to EU5 Eurovent 4/5 94% arrestance. The housing is galvanised sheet metal with spigots fitted with integral seals. Quick release catches allow easy access to the bag filter. Replacement bag filters are available.

### Resistance Graph

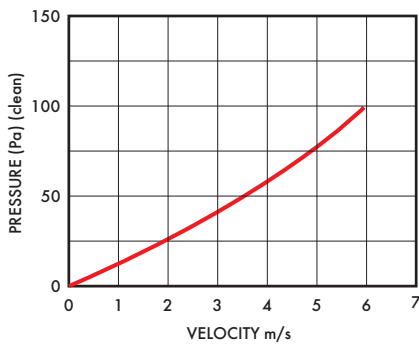

Stock Ref	Dia	Spare filter
10533100	100mm	10557150
10533125	125mm	10557150
10533150	150mm	10557150
10533200	200mm	10557200
10533250	250mm	10557250
10533315	315mm	10557315
10533400	400mm	10557400
10533500	500mm	10557500

### Dimensions (mm)

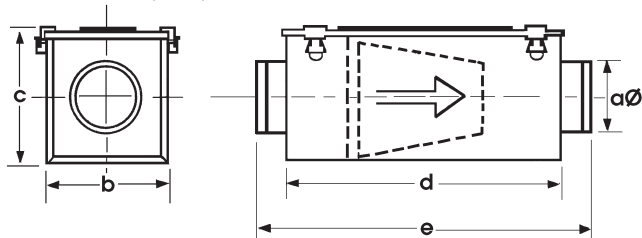

Stock Ref	Øa	b	c	d	e	kgs
10533100	100	200	203	450	540	4
10533125	125	200	203	450	540	4
10533150	150	200	203	450	540	4
10533200	200	245	248	450	560	5
10533250	250	295	298	500	620	7
10533315	315	345	348	550	670	8.5
10533400	400	445	448	650	770	12
10533500	500	600	600	650	770	12

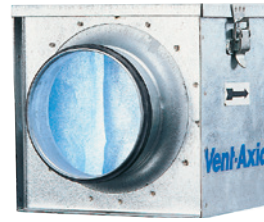

## Pre-Filter Cassettes

Pre-filter cassettes are available in a range of seven sizes and are tested to EU3 (Eurovent 4/5) 85% arrestance. Housing is in galvanised sheet metal. Spigots are fitted with integral seals. Quick release catches allow access to the filter medium. Replacement pre-filters are available.

### Resistance Graph

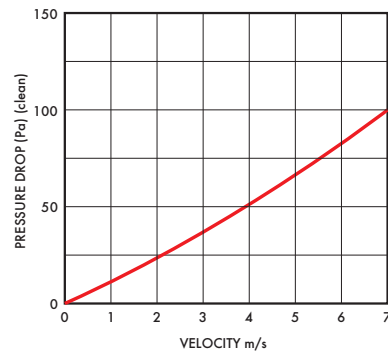

### Dimensions (mm)

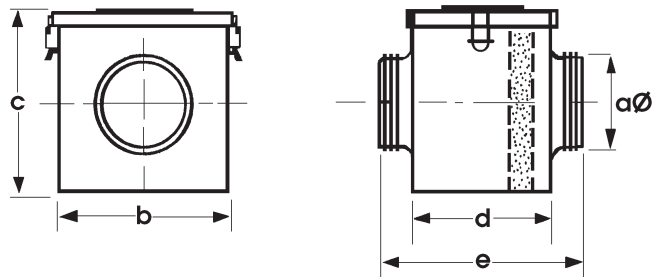

Stock Ref	Øa	b	c	d	e	kg
10532100	100	205	170	120	227	2
10532125	125	215	205	140	252	2
10532150	150	265	235	155	267	3
10532200	200	315	275	180	302	3.5
10532250	250	365	325	230	352	5.5
10532315	315	425	390	330	452	7
10532400	400	515	495	455	487	10.5

Diameter	Pre-filter cassettes	
	Stock Ref	Spare filter Stock Ref
100mm	10532100	10556100
125mm	10532125	10556125
150mm	10532150	10556150
200mm	10532200	10556200
250mm	10532250	10556250
315mm	10532315	10556315
400mm	10532400	10556400

# Accessories

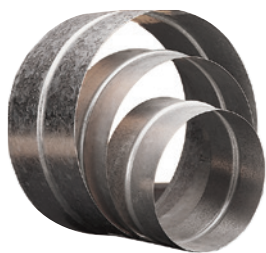

## Joining Pieces

Used to join lengths of flexible ducting to give a long-lasting airtight connection. Manufactured from galvanised steel. Available in 100, 125, 150, 200, 315 and 400mm diameter sizes.

### Dimensions (mm)

Stock Ref	Dia
561804	100
561805	125
561806	150
561808	200
561810	250
561813	315



## Duct 'Y' Piece

For dividing a ventilation system, providing ducting to multiple supply or extract grilles using only a single fan source. Available in fire retardant ABS.

### Dimensions (mm)

Vent-Axia Duct Y Piece		
2 x Dia.	Into 1 x Dia.	Stock Ref
100	100	452081
100	150	452082
125	125	455211
125	150	455212
150	150	452083
150	200	452084
200	200	452085
200	250	452078
250	250	452076
250	300	452079



## Worm Drive clips

Stainless steel bands used for securing flexible ducting. Available to fit 100, 125, 150, 200, 250, 315, 355, 400, 450, 500, 560 and 630mm diameter sizes.

### Dimensions (mm)

Stock Ref	Dia
561704	100
561707	125
561707	150
561710	200
561710	250
561715	315
561715	355
561720	400
561720	450
561720	500
561726	560
561726	630

# Accessories



## Louvred Shutters

A range of twelve sizes of shutter with gravity return flaps to protect against backdraughts. The frame is manufactured from high impact polystyrene and the louvres from P.V.C. All components are UV stabilised.

## Resistance Graph

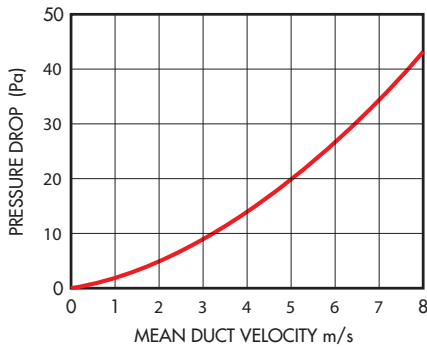

## Dimensions (mm)

Typical Installation

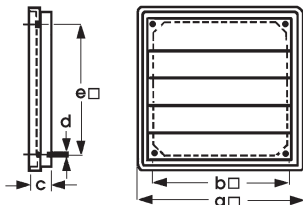

Stock

Fixing hole

Ref	Dia.	a □	*b □	c	Ød	e □
LS100	100mm	139	100	15	4	95
LS125	125mm	160	135	15	5	110
LS150	150mm	180	155	20	5	130
LS200	200mm	242	205	20	5	182
LS250	250mm	294	265	25	5	230
LS315	315mm	360	310	27	5	295
LS350	355mm	411	349	27	5	329
LS400	400mm	456	409	27	5	382
LS450	450mm	505	458	27	5	432
LS500	500mm	560	508	27	5	477
LS560	560mm	605	565	31	5	533
LS630	630mm	696	657	31	5	626

\* Fixing hole



## Louvred Grilles

Louvred grilles can be used for air replacement for extract purposes and as an external louvre. Available in four sizes, the assembly fits over, rather than into the aperture making it especially useful where there are space restrictions within the duct. Manufactured in thermoplastic. Choice of three colours: Ivory, Brown or Grey.

## Resistance Graph

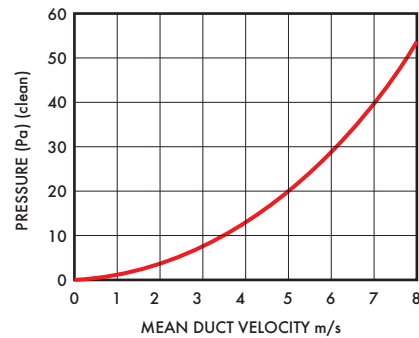

## Dimensions (mm)

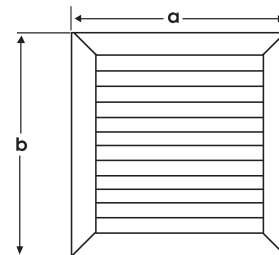

Louvred grilles

Stock Ref	Colour	hole size	a	b
W561431	Grey	230mm	310	303
561421	Ivory	230mm	310	303
561411	Brown	230mm	310	303
W561432	Grey	270mm	351	344
561422	Ivory	270mm	351	344
561412	Brown	270mm	351	344
W561433	Grey	300mm	391	388
561423	Ivory	300mm	391	388
561413	Brown	300mm	391	388
W561434	Grey	380mm	470	467
561424	Ivory	380mm	470	467
561414	Brown	380mm	470	467



# Accessories

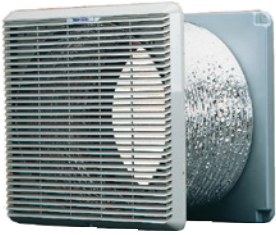

## Wall or Window Termination Sets

Used to terminate flexible ducting at walls utilising worm drive clips. Flexible wall sleeve and fixing rods can be cut to suit varying wall thicknesses up to 360mm.

Consists of: Direct mount spigot, grille, flexible wall sleeve and all fixings.

## Resistance Graph

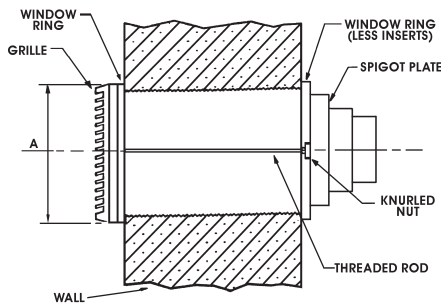
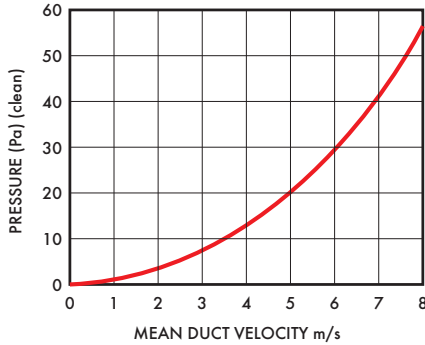

Spigot Dia.	Grille Size 'A' H x W	Hole required in		Stock Ref
		wall Ø	window Ø	
100mm	220 x 226	210	184	W10554150
125mm	220 x 226	210	184	W10554150
150mm	220 x 226	210	184	W10554150
200mm	258 x 265	240	222	W10554200
250mm	302 x 304	290	260	W10554250
315mm	378 x 381	370	337	W10554315



## Roof Termination Sets

Used to terminate flexible ducting at roofs utilising worm drive clips.

Consists of: Direct mount spigot, adaptor kit, roof cowl, deflector and all screws.

## Resistance Graph

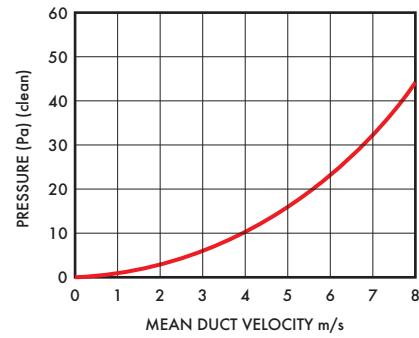

## Dimensions (mm)

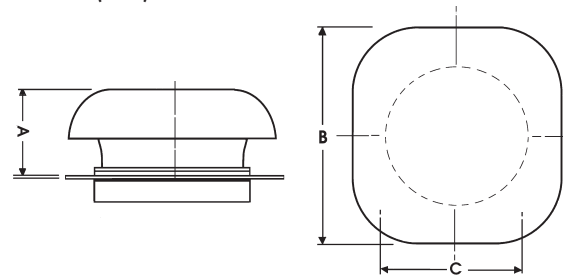

Dia.	a	b	cØ	Stock Ref
100mm	100	285	184	10555150
125mm	100	285	184	10555150
150mm	100	285	184	10555150
200mm	136	400	222	10555200
250mm	136	400	260	10555250
315mm	171	500	337	10555315

Roof plate assembly	
Termination Set	Roof Plate Assembly
10555150	560136
10555200	560137
10555250	560139
10555315	560142

# Accessories



## Backdraught Shutters

Duct sleeve manufactured from galvanised steel. The circular butterfly shutter is fitted with a return spring for positive closing.

Available in 100, 125, 150, 200, 250, and 315mm diameter sizes.

## Resistance Graph

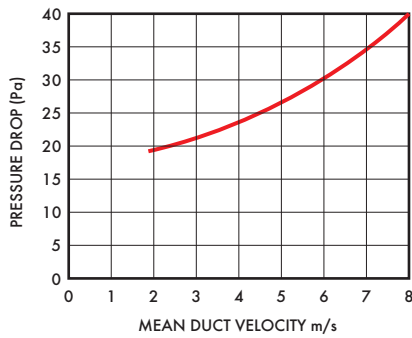

## Dimensions (mm)

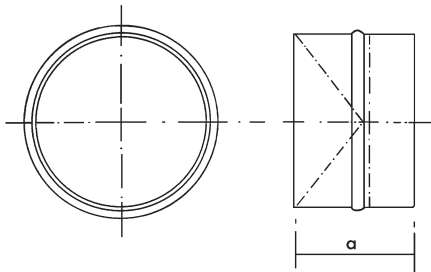

Stock Ref	Dia	a
10542100	100	88
10542125	125	88
10542150	150	88
10542200	200	88
10542250	250	128
10542315	315	128



## Fast Clamps

Used to connect rigid ductwork to Airtrak fans. The clamp is manufactured from galvanised steel and features a thick neoprene rubber pad which is fixed on the inside. The clamp acts effectively as a vibration absorber and a noise suppressor. The fast clamp is tightened by two quick release bolts. Available in 100, 125, 150, 200, 315 and 400mm diameter sizes.

Max. operating temperature 150°C.

## Dimensions (mm)

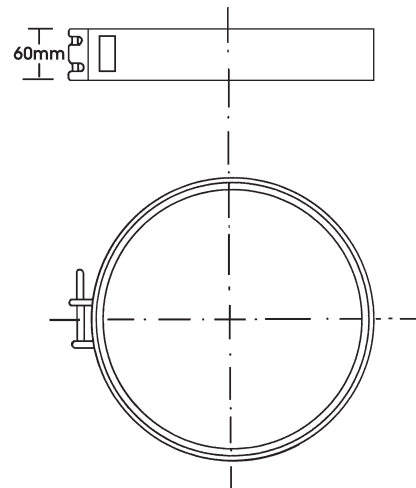

Stock Ref	Dia
10540125	100
10540125	125
10540150	150
10540200	200
10540250	250
10540315	315

# Accessories



## Duct Attenuators

Easily installed, the duct attenuator is used in the system to absorb sound. Available in 100, 125, 150, 200, 250, 315 and 400mm diameter sizes. Manufactured in galvanised sheet metal with 50mm Rockwool sound absorption material. Maximum operating temp. 100°C.

### Dimensions (mm)

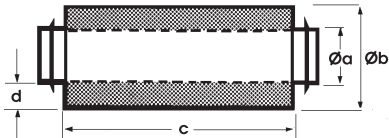

Stock Ref	Øa	Øb	c	d	kg
10534100	100	200	300	50	2.4
10534125	125	225	300	50	2.6
10534150	150	250	300	50	4.1
10535100	100	200	600	50	2.9
10535125	125	225	600	50	4.5
10535150	150	250	600	50	5.8
10535200	200	315	600	57.5	7
10535250	250	355	600	52.5	8.6
10535315	315	450	600	67.5	9.8
10535400	400	630	600	115	18
10536100	100	200	900	50	6.6
10536125	125	225	900	50	7.6
10536150	150	250	900	50	9
10536200	200	315	900	57.5	10
10536250	250	355	900	52.5	12.2
10536315	315	450	900	67.5	15
10536400	400	630	900	115	21
10537200	200	315	1200	57.5	14
10537250	250	355	1200	52.5	18
10537315	315	450	1200	67.5	21
10537400	400	630	1200	115	27

## Resistance Graph

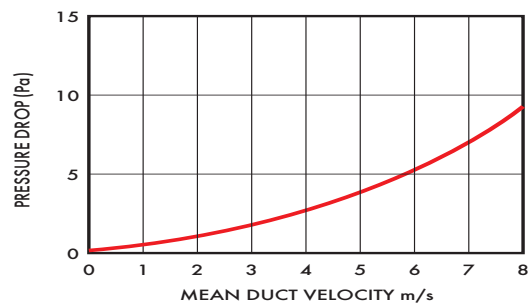

## Duct Attenuator Insertion Losses

Stock Ref	Length	Duct Ø	63	125	250	500	1k	2k	4k	8k
10534100	300	100	3	4	10	18	23	25	25	12
10534125	300	125	3	4	8	17	21	23	21	11
10534150	300	150	3	3	6	14	20	23	21	11
10535100	600	100	5	8	16	33	39	40	36	17
10535125	600	125	4	8	13	30	34	35	31	15
10535150	600	150	4	7	13	23	29	36	31	15
10535200	600	200	4	5	11	21	26	32	20	9
10535250	600	250	3	6	10	19	24	29	19	8
10535315	600	315	3	5	8	16	21	22	16	15
10535400	600	400	3	4	7	14	18	19	14	13
10536100	900	100	10	13	20	39	45	38	35	18
10536125	900	125	9	12	18	37	41	37	32	16
10536150	900	150	8	9	15	30	37	37	33	17
10536200	900	200	7	9	14	27	31	36	25	12
10536250	900	250	5	8	13	24	30	31	22	11
10536315	900	315	4	7	11	20	31	27	17	12
10536400	900	400	4	6	9	18	26	24	16	11
10537200	1200	200	10	12	17	35	40	43	27	13
10537250	1200	250	7	9	15	31	36	38	26	12
10537315	1200	315	6	8	13	23	32	30	18	11
10537400	1200	400	5	8	12	20	29	27	17	9

# Accessories



## Circular Supply & Exhaust Diffusers

Manufactured from powder coated steel. Suitable for supplying or exhausting air and can be fitted directly to the duct or in the ceiling. Available in 100 and 125mm diameter sizes.

### Dimensions (mm)

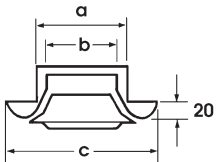

Dia.	Model	Ref	Stock				Weight	
			a	b	c	kg	kg	
100	Supply	10543100A	100	80	150	0.15	0.09	
125	Exhaust	10544125A	125	96	158	0.15	0.13	



## Plenum Boxes

The Plenum box allows square grilles and diffusers to connect to circular duct. Each box size has a two diameter circular spigot for maximum versatility. The box is deep enough to accommodate both a double deflection grille and opposed blade damper.

Manufactured in flame retardant high impact recyclable thermoplastic.

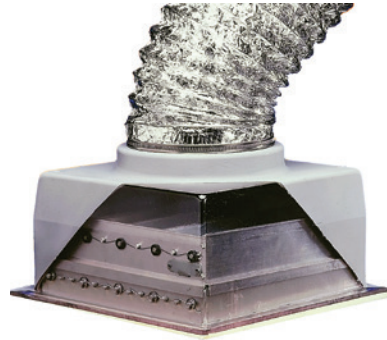

### Dimensions (mm)

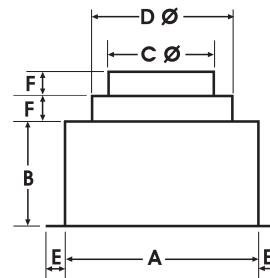

Stock Ref	A	B	CØ	DØ	E	F
560601	200	130	125	150	25	25
560602	250	130	150	175	25	25
560603	300	130	200	225	25	25
560604	300	130	250	300	25	25
560605	450	130	315	400	25	25

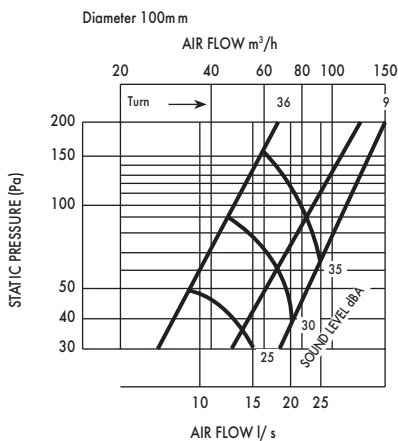

eg. 100mm diameter supply diffuser. Design 15l/s flow  
3 turns ~ 30-35 dBA ~ 130Pa  
6 turns ~ 25-30 dBA ~ 40Pa

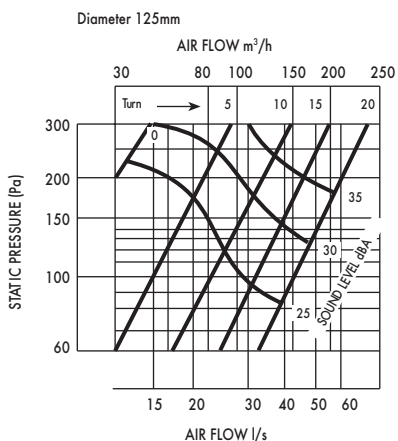

# Accessories



## Single Deflection Grilles

Suitable for either sidewall or exposed duct applications. A single row of blades permits up to 45° deflection of the air in one plane. Satin silver finish.

Size 6/7 fits 300mm square modular size and size 9/12 fits 450mm square modular size.

Unit size	Module size	Stock Ref
Size 6/7	300 mm <input type="checkbox"/>	561372
Size 9/12	450 mm <input type="checkbox"/>	561373
Also available in the following sizes:-		
	200mm <input type="checkbox"/>	561370
	250mm <input type="checkbox"/>	561371



## Eggcrate Grilles - Satin silver & white finish

Eggcrate grilles can be used for air replacement or air extract purposes.

Used underneath Roof Plate Assemblies with roof models, underneath single spigots in ceilings, underneath mounting boxes and on the inside faces of walls that have units in fixed and removable wall plates on the outside of the wall.

Comprising a 13mm square by 13mm deep mesh eggcrate core housed in a frame which has a satin silver or white finish.

Size 6/7 fits 300mm square modular size and size 9/12 fits 450mm square modular size.

Size 6/7 - 785cm<sup>2</sup> free area  
Size 9/12 - 1810cm<sup>2</sup> free area

### Eggcrate grilles satin silver finish

Unit size	Module size	Stock Ref
Size 6/7	300 mm <input type="checkbox"/>	561301
Size 9/12	450 mm <input type="checkbox"/>	561302
Also available in the following sizes:-		
	200mm <input type="checkbox"/>	561303
	250mm <input type="checkbox"/>	561305

### Eggcrate grilles white finish

Unit size	Module size	Stock Ref
Size 6/7	300 mm <input type="checkbox"/>	560849
Size 9/12	450 mm <input type="checkbox"/>	560850
Also available in the following sizes:-		
	125mm <input type="checkbox"/>	560846
	200mm <input type="checkbox"/>	560847

# Accessories



## 4-Way Diffusers

Manufactured in light polypropylene plastic. With four diffuser cassettes which can be set for downward or 45 degree discharge in any of sixteen directional combinations.

Stock Ref	Neck Size	Colour
10546230	225mm <input type="checkbox"/>	Ivory
10546300	300mm <input type="checkbox"/>	Ivory
10546350	350mm <input type="checkbox"/>	Ivory
10546400	400mm <input type="checkbox"/>	Ivory
10546450	450mm <input type="checkbox"/>	Ivory
10546500	500mm* <input type="checkbox"/>	Ivory

\* Fits ceiling grid size 595mm

## Dimensions (mm)

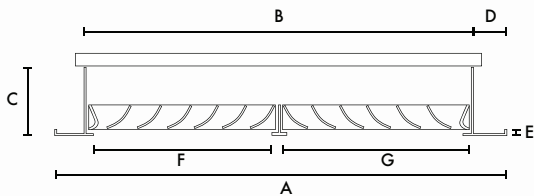

Stock Ref	a <input type="checkbox"/>	b <input type="checkbox"/>	c	d	e	f <input type="checkbox"/>	g <input type="checkbox"/>
10546230	265	224	60	20	5	102	112
10546300	335	292	60	22	5	136	140
10546350	390	345	60	22	5	162	168
10546400	440	395	75	22	8	183	190
10546450	490	459	75	22	8	208	215
10546500	595	495	70	50	10	236	240

Diffuser	Neck Adaptor		
Stock Ref	Sock Ref		Duct Ø
10546230	OR	10547150	150
10546230	OR	10547200	200
10546300		10547250	250
10546350		10547300	300
10546400		10547400	400
10546450		10548400	400
10546500		10548000	315/400

## Performance

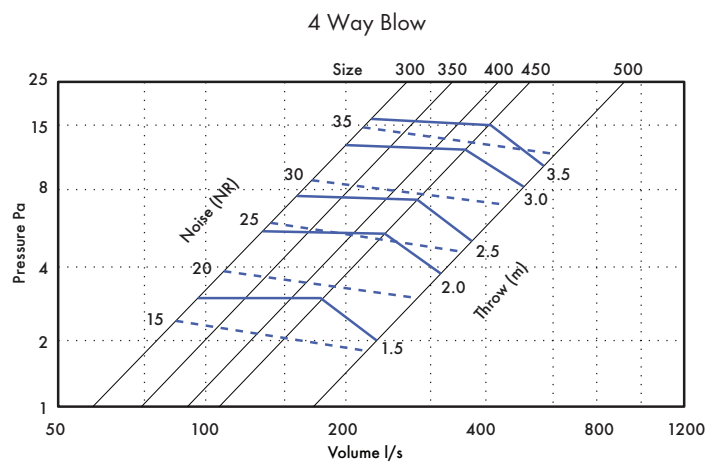
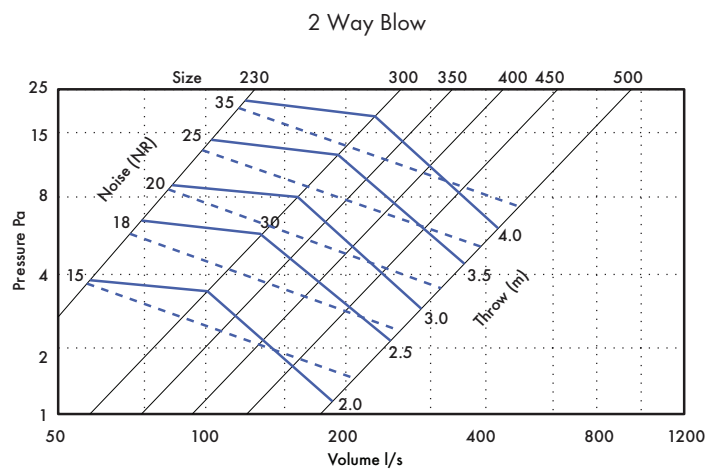
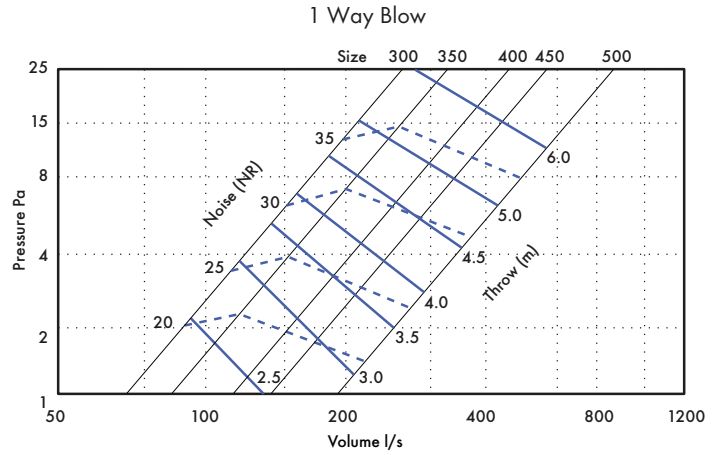

# Accessories

## Optional Air Flow Direction

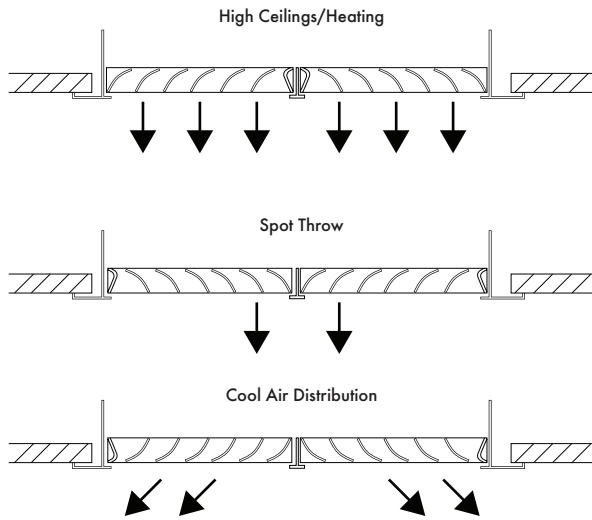
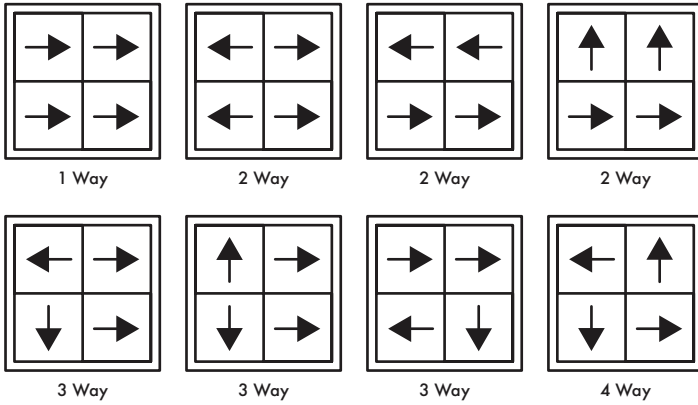

## Mounting Types

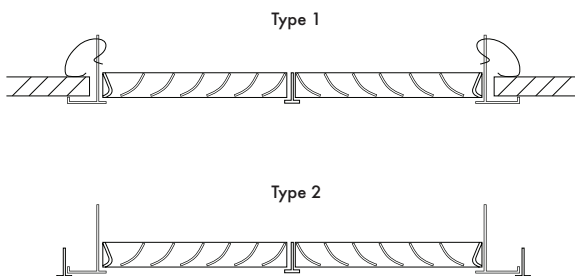

## Neck Adaptors

Used to connect flexible ducting directly to 4-way diffusers for intake/extract applications.

Stock Ref	4 - way diffuser size	Duct Ø
10547150	225mm	150mm
10547200	225mm	200mm
10547250	300mm	250mm
10547300	350mm	315mm
10547400	400mm	400mm
10548400	450mm	400mm
10548000	500mm	315/400mm

## Dimensions (mm)

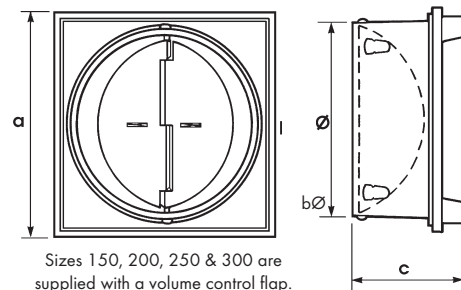

Sizes 150, 200, 250 & 300 are supplied with a volume control flap.

Stock Ref	Duct Dia.	a	Øb	c
10547150	150	235	145	115
10547200	200	235	195	115
10547250	250	305	245	115
10547300	300/315	355	295	110
10547400	400	407	400	90
10548400	400	459	400	92
10548000	315/400	500	315/400	168 max





## VENT-AXIA CONTACT NUMBERS

Free technical, installation and sales advice is available

Sales Tel:	0344 856 0590
Tech Support Tel:	0344 856 0594
Tech Support Email:	tech@vent-axia.com
Web:	www.vent-axia.com
Email:	sales@vent-axia.com

### Supply & Service

All sales made by Vent-Axia Limited are made only upon the terms of the Company's Conditions of Sale, a copy of which may be obtained on request. As part of the policy of continuous product improvement Vent-Axia reserves the right to alter specifications without notice.



Download our Knowledge Hub app - Your new pocket expert.

Search, View, Share - It's that easy!



Made in Britain