

Vent Duct Fire Sleeves

- Fire rated product up to EI 120 minutes
- Tested for masonry, concrete and plasterboard walls
- Tested in external wall / SFS constructions
- Can be installed within Ablative Coated Fire Batts
- CE Marked
- U/U - Uncapped/Uncapped tested as required for ventilated systems
- Can be retro fitted
- Low profile design
- Available preformed and ready to install in both circular or rectangular shapes
- Compressible material, offers accommodation for deflection
- No metal sleeving or boxing out required

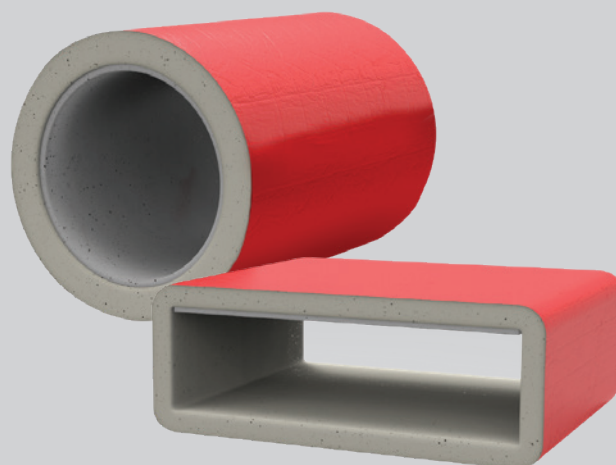

The FF109 Vent Duct Fire Sleeve Low Profiles (VDS LPs) are a family of CE Marked fire penetration seals designed to firestop PVC ventilation ducts/ pipes when installed through fire rated constructions.

The unique vacuum formed intumescent material design ensures that the expansion direction of the material crushes and seals the ducting in a fire situation without the need for any additional support or metal sleeving.

The lack of metal sleeving, not only makes installation easy, it also limits the risk of heat transfer through the structure as well as allowing compression to ensure a tight seal against fire and smoke or tight fitting against the ceiling soffit where needed.

The Fire Sleeves provide fire resistance ratings for Integrity (E) and Insulation (I) for up to EI120 minutes depending on the construction.

Fire Tested for both internal and external wall constructions. The Fire Sleeves are CE Marked with a European Technical Approval (ETA) based on extensive fire testing to BS EN 1366-3.

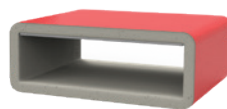

Rectangular Fire sleeve - Low profile - 4 sided

Thickness:			10-15mm
CE Marked			
Duct Size	Length		Stock Ref
110x54mm	180mm		407658
204x60mm	180mm		407659
204x60mm	360mm		474720
220x90mm	180mm		407660

Models

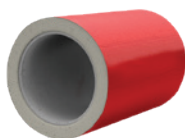

Round Fire Sleeve - Low profile

Thickness:	10-15mm
Length:	280mm (180mm 407655)
CE Marked	
Duct Size	Stock Ref
100mm	407655
125mm	407656
150mm	407657

Installation Variations

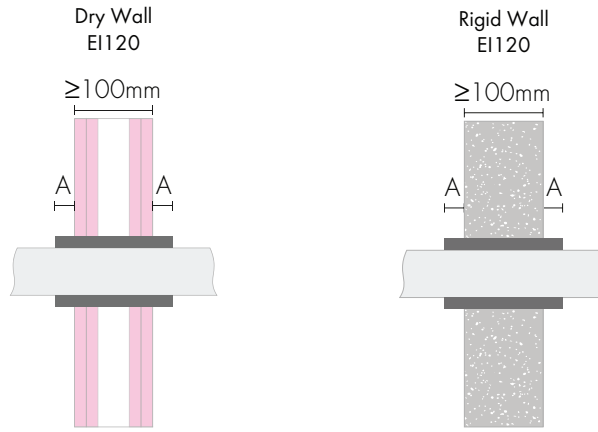

Test Standard	Duct Size Ref.	Duct Size (mm)	Duct Size Range (mm)	Wall		Min. Sleeve Length (mm)	Min. Protrusion (A) (mm)	Fire Rating	End Cap Conf.	Report No.
				Thickness (mm)	Material					
EN 1366-3	100	103	15-103	1.5	PVC	150	25	EI120	U/U	ETA 20-1164
EN 1366-3	125	127	15-127	1.8	PVC	250	75	EI120	U/U	ETA 20-1164
EN 1366-3	150	155	15-155	2.0	PVC	250	75	EI120	U/U	ETA 20-1164
EN 1366-3	110x54	110x54	110x54	1.5-1.8	PVC	150	25	EI120	U/U	ETA 20-1164
EN 1366-3	204x60	204x60	204x60	1.5-1.8	PVC	150	25	EI120	U/U	ETA 20-1164
EN 1366-3	220x90	220x90	220x90	1.5-1.8	PVC	150	25	EI120	U/U	ETA 20-1164

Service Support must be max. 300mm from the surface of the wall

Seals must be minimum 200mm apart

Rigid Walls must comprise concrete, aerated concrete or masonry with a minimum density of 650 kg/m³ (wall type A, see ETA) or concrete or masonry with a minimum density of 1100 kg/m³ (wall type B).

Flexible Wall (external) EI90

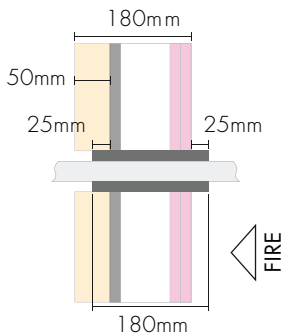

Construction Build-Up

Celotex PIR Foil Faced Insulation 50mm thick / 31kg/m³

Siniat GTEC Weather Defence Board SE 1x12.5mm

Rockwool ProRox SL920 Rock Fibre Insulation 100mm thick / 45kg/m³

Metsec Steel Stud 90mm wide

Siniat GTEC Fire Board SE Plasterboard 2x12.5mm

Test Standard	Duct Size Ref.	Duct Size (mm)	Duct Size Range (mm)	Wall Thickness (mm)	Material	Min. Sleeve Length (mm)	Min. Protrusion (mm)	Fire Rating	End Cap Conf.	Report No.
EN 1366-3	100	103	15-103	1.8	PVC	180	25	EI90	U/U	WF 411551
EN 1366-3	125	127	15-127	1.8	PVC	180	25	EI90	U/U	WF 411551
EN 1366-3	110x54	110x54	110x54	2.25 (+/- 0/15mm)	PVC	180	25	EI90	U/U	WF 411551
EN 1366-3	204x60	204x60	204x60	2.25 (+/- 0/15mm)	PVC	180	25	EI90	U/U	WF 411551
EN 1366-3	220x90	220x90	220x90	2.25 (+/- 0/15mm)	PVC	180	25	EI90	U/U	WF 411551

Service Support must be max. 300mm from the surface of the wall

Seals must be minimum 200mm apart

Note: Vent-Axia does not guarantee compliance with Building Regulations Part B, Fire Spread or other regulations that relate to fire planning. Suitability to comply with these regulations should be determined prior to installation and in conjunction with Building Control Officers. Compliance with the Regulations is specifically excluded from quotations and designs. For further information, please contact our technical support department.

Installation Variations

Fire Batt
100, 110x54, 204x60 & 220x90mm ducts only
30/60 mins

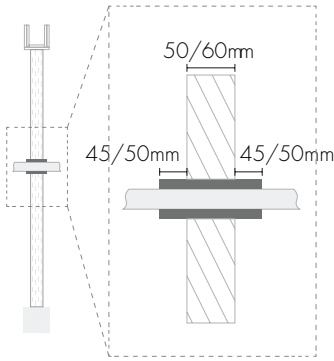

Fire Batt
125 & 150mm ducts only
30/60 mins

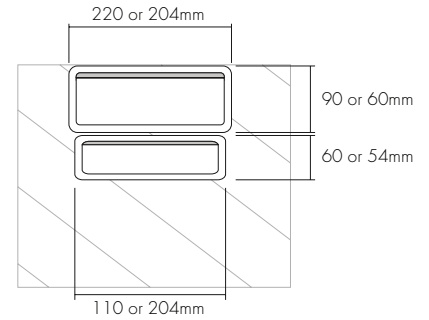
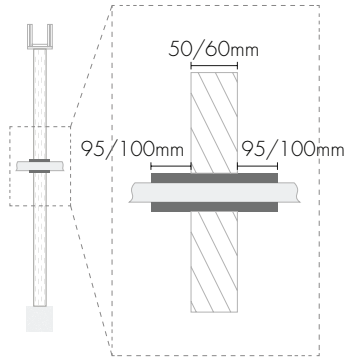

Fire Batt
100, 110x54, 204x60 & 220x90mm ducts only
90/120 mins

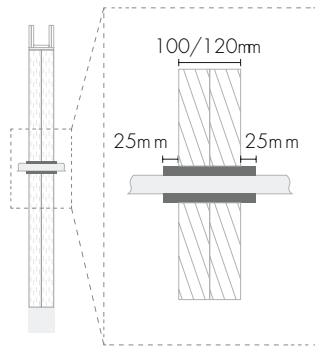

Fire Batt
125 & 150mm ducts only
90/120 mins

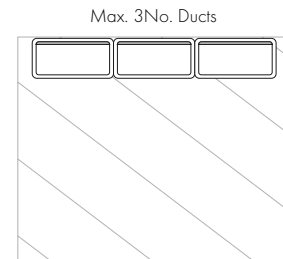
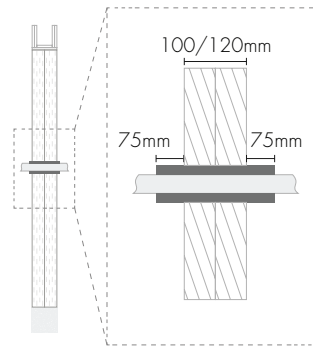

Test Standard	Duct Size Ref.	Duct Size (mm)	Wall Thickness (mm)	Material	Std. Sleeve Length (mm)	Min. Protrusion (mm)	Soffit Fix Allowed	Side by Side Installation	Stacked Ducts Allowed	Fire Rating	End Cap Configuration	Report No.
BS 476 Pt. 22	100	103	1.5	PVC	180	45/50mm or 25mm	N	N	N	30, 60, 90, 120	U/U	PAR/15162/01
BS 476 Pt. 22	125	127	1.8	PVC	280	95/100mm or 75mm	N	N	N	30, 60, 90, 120	U/U	PAR/15162/01
BS 476 Pt. 23	150	155	2.0	PVC	280	95/100mm or 75mm	N	N	N	30, 60, 90, 120	U/U	PAR/15162/01
BS 476 Pt. 22	110x54	110x54	1.5	PVC	180	45/50mm or 25mm	Y	Y	Y	30, 60, 90, 120	U/U	PAR/15162/01
BS 476 Pt. 22	204x60	204x60	1.5-1.8	PVC	180	45/50mm or 25mm	Y	Y	Y	30, 60, 90, 120	U/U	PAR/15162/01
BS 476 Pt. 22	220x90	220x90	1.8	PVC	180	45/50mm or 25mm	Y	Y	Y	30, 60, 90, 120	U/U	PAR/15162/01

Ablative Coated Batts, 50 or 60mm thick, must have suitable supporting documentation to demonstrate to the fire ratings required in accordance with BS476: Part 22

Min. spacing to seal edge or between penetrations must be 50mm

When rectangular ducts fixed underside the soffit, top edge of Fire Sleeve must be tight to the soffit, max. 5mm gaps allowable if sealed with intumescent acrylic sealant

When rectangular ducts fixed side by side, limited to maximum 3No., adjacent Fire Sleeves must be in close and constant contact

When rectangular ducts fixed side by side, ducts must be of the same size

When stacked ducts are installed, max. 2no. Stacked ducts of the same or similar size, e.g. 220x90 and 204x60 or 204x60 and 110x54.

Please refer to PAR/15162/01 for more limitations on multiple duct installations

Service Supports must be max. 300mm from the surface of the wall

Individual seal openings must be minimum 200mm apart

Installation Variations

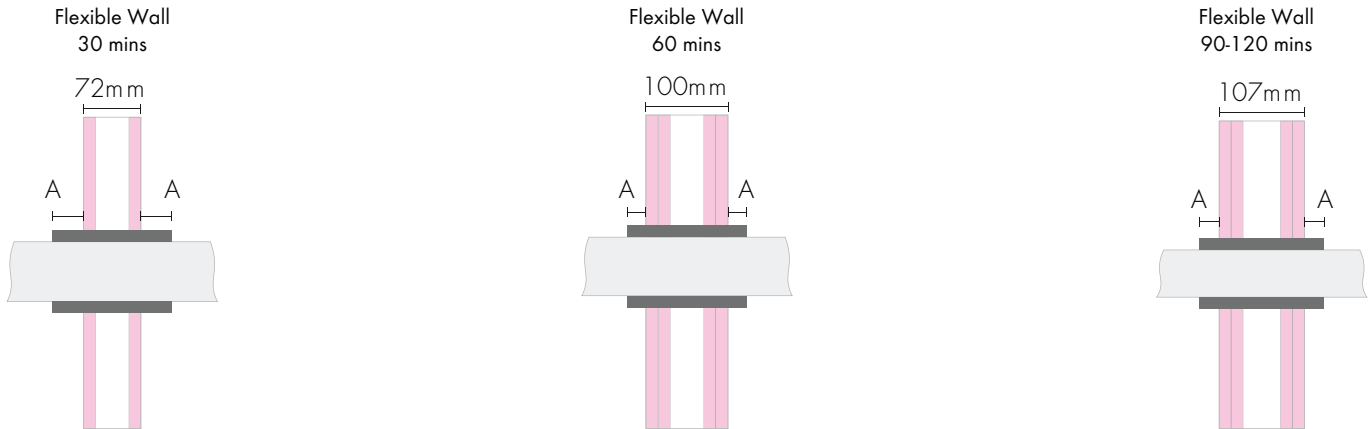

Test Standard	Duct Size Ref.	Duct Size (mm)	Wall Thickness (mm)	Material	Std. Sleeve Length (mm)	Min. Protrusion		Soffit Fix Allowed	Side by Side Installation	Fire Rating	End Cap Config.	Report No.
						in 72-99mm thick walls (mm)	in ≥100mm thick walls (mm)					
BS 476 Pt. 22	100	103	1.5	PVC	180	39	25	N	N	30,60,90,120	U/U	PAR/14600/01
BS 476 Pt. 22	125	127	1.8	PVC	280	89	75	N	N	30,60,90,120	U/U	PAR/14600/01
BS 476 Pt. 22	150	155	2.0	PVC	280	89	75	N	N	30,60,90,120	U/U	PAR/14600/01
BS 476 Pt. 22	110x54	110x54	1.5	PVC	180	39	25	Y	Y	30,60,90,120	U/U	PAR/14600/01
BS 476 Pt. 22	204x60	204x60	1.5-1.8	PVC	180	39	25	Y	Y	30,60,90,120	U/U	PAR/14600/01
BS 476 Pt. 22	220x90	220x90	1.8	PVC	180	39	25	Y	Y	30,60,90,120	U/U	PAR/14600/01

When rectangular ducts fixed underside the soffit, top edge of Fire Sleeve must be tight to the soffit, max. 5mm gaps allowable if sealed with intumescent acrylic sealant

When rectangular ducts fixed side by side, limited to maximum 3No., adjacent Fire Sleeves must be in close and constant contact

When rectangular ducts fixed side by side, ducts must be of the same size

Please refer to PAR/14600/01 for more limitations on multiple duct installations

Service Supports must be max. 300mm from the surface of the wall

Individual seal openings must be minimum 200mm apart

Dimensions

Duct Size	Nominal Thickness	Nominal External Width /		Length
		Diameter	Nominal External Height	
110x54mm	10-15mm	134mm	83mm	180mm
204x60mm	10-15mm	228mm	89mm	180mm
204x60mm	10-15mm	228mm	89mm	360mm
220x90mm	10-15mm	244mm	124mm	180mm
220x90mm	10-15mm	244mm	124mm	360mm
100mm (103mm)	15mm	244mm	-	180mm
125mm (127mm)	15mm	160mm	-	280mm
150mm (155mm)	20mm	200mm	-	280mm

Physical Properties

Properties

Colour
 Finish
 Cuttability
 Compressibility
 Working Life
 Storage
 Transportation storage temperature
 Durability
 Smoke/Halogen Content

Detail

Red
 Glossy label on reinforced aluminium foil
 Can be cut lengthways to retrofit
 Does compress
 48 years
 Dry, ambient
 -20°C to +70°C
 Type X intended for use in conditions exposed to weather (UV, rain, frost)
 Low Smoke / Zero Halogen

Maintenance

No active maintenance required, where alterations are made around the product it should be checked visually to ensure that the product is still installed as per fitting instructions and tested systems.

Fitting Instructions

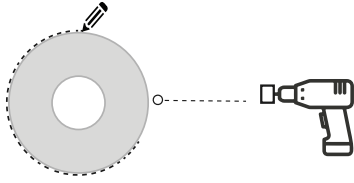

Step 1a

If using a hole cutter for circular holes, ensure that the correct fire sleeve wall thickness (15mm + 15mm) 30mm total is added to the diameter of the pipe, this equals the aperture size. Cut the hole through the substrate using the correct blade, in the required location.

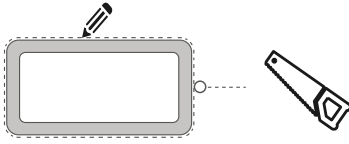

Step 1b

If cutting without a hole cutter, using a pencil, draw around the fire sleeve at the required position of the aperture, ensure a tightly marked line. Use this line to cut the aperture through the substrate, using the required equipment as appropriate.

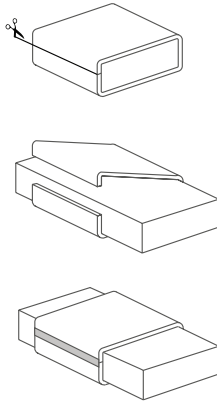

Step 2

Unless the sleeve can be slid down the length of pipe/vent/duct to the aperture, carefully cut along the length of the fire sleeve, using a sharp knife or scissors, on a rectangular duct/vent cut centrally to one of the sides, place the sleeve around the pipe/duct/vent close to the aperture, and apply foil tape over the joint, where the sleeve was cut.

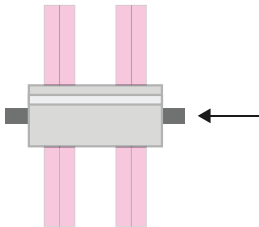

Step 3

Push gently on the sleeve to pass it through the wall, if the sleeve covering starts to tear or if excessive resistance is felt, pull the sleeve back and trim the aperture. The sleeve should be pushed into the required position, ensuring that the required length of sleeve protrudes on either side of the wall.

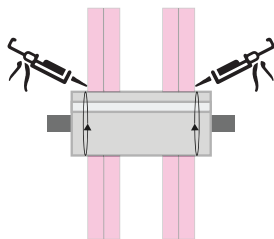

Step 4 (If required)

If required for the purpose of smoke and draft stop, air or water tightness and airborne sound insulation, the gap between opening edge and fire sleeve may be sealed off by a suitable acrylic intumescent mastic construction sealant approved for penetration sealing applications.

